

C R D 6 8 0 0 L i t h i u m - I o n
C r a d l e

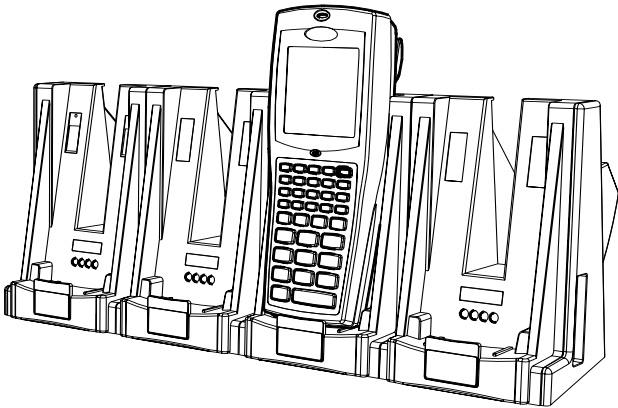

symbol[®]

C R D 6 8 0 0 L i t h i u m - I o n C r a d l e

© 2002 SYMBOL TECHNOLOGIES, INC. All rights reserved.

Symbol reserves the right to make changes to any product to improve reliability, function, or design.

Symbol does not assume any product liability arising out of, or in connection with, the application or use of any product, circuit, or application described herein.

No license is granted, either expressly or by implication, estoppel, or otherwise under any patent right or patent, covering or relating to any combination, system, apparatus, machine, material, method, or process in which Symbol products might be used. An implied license exists only for equipment, circuits, and subsystems contained in Symbol products.

Symbol and the Symbol logo are registered trademarks of Symbol Technologies, Inc. Other product names mentioned in this manual may be trademarks or registered trademarks of their respective companies and are hereby acknowledged.

Symbol Technologies, Inc.
One Symbol Plaza
Holtsville, N.Y. 11742-1300
<http://www.symbol.com>

Patents

This product is covered by one or more of the following U.S. and foreign Patents:

U.S. Patent No. 4,496,831; 4,593,186; 4,603,262; 4,607,156; 4,652,750; 4,673,805;
4,736,095; 4,758,717; 4,760,248; 4,806,742; 4,816,660; 4,845,350; 4,896,026; 4,897,532;
4,923,281; 4,933,538; 4,992,717; 5,015,833; 5,017,765; 5,021,641; 5,029,183; 5,047,617;
5,103,461; 5,113,445; 5,130,520; 5,140,144; 5,142,550; 5,149,950; 5,157,687; 5,168,148;
5,168,149; 5,180,904; 5,216,232; 5,229,591; 5,230,088; 5,235,167; 5,243,655; 5,247,162;
5,250,791; 5,250,792; 5,260,553; 5,262,627; 5,262,628; 5,266,787; 5,278,398; 5,280,162;
5,280,163; 5,280,164; 5,280,498; 5,304,786; 5,304,788; 5,306,900; 5,321,246; 5,324,924;
5,337,361; 5,367,151; 5,373,148; 5,378,882; 5,396,053; 5,396,055; 5,399,846; 5,408,081;
5,410,139; 5,410,140; 5,412,198; 5,418,812; 5,420,411; 5,436,440; 5,444,231; 5,449,891;
5,449,893; 5,468,949; 5,471,042; 5,478,998; 5,479,000; 5,479,002; 5,479,441; 5,504,322;
5,519,577; 5,528,621; 5,532,469; 5,543,610; 5,545,889; 5,552,592; 5,557,093; 5,578,810;
5,581,070; 5,589,679; 5,589,680; 5,608,202; 5,612,531; 5,619,028; 5,627,359; 5,637,852;
5,664,229; 5,668,803; 5,675,139; 5,693,929; 5,698,835; 5,705,800; 5,714,746; 5,723,851;
5,734,152; 5,734,153; 5,742,043; 5,745,794; 5,754,587; 5,762,516; 5,763,863; 5,767,500;
5,789,728; 5,789,731; 5,808,287; 5,811,785; 5,811,787; 5,815,811; 5,821,519; 5,821,520;
5,823,812; 5,828,050; 5,848,064; 5,850,078; 5,861,615; 5,874,720; 5,875,415; 5,900,617;
5,902,989; 5,907,146; 5,912,450; 5,914,478; 5,917,173; 5,920,059; 5,923,025; 5,929,420;
5,945,658; 5,945,659; 5,946,194; 5,959,285; 6,002,918; 6,021,947; 6,031,830; 6,036,098;
6,047,892; 6,050,491; 6,053,413; 6,056,200; 6,065,678; 6,067,297; 6,068,190; 6,082,621;
6,084,528; 6,088,482; 6,092,725; 6,101,483; 6,102,293; 6,104,620; 6,114,712; 6,115,678;
6,119,944; 6,123,265; 6,131,814; 6,138,180; 6,142,379; 6,172,478; 6,176,428; 6,178,426;
6,186,400; 6,188,681; 6,209,788; 6,216,951; 6,220,514; 6,243,447; 6,244,513; 6,247,647;
6,308,061; 6,250,551; 6,295,031; D305,885; D341,584; D344,501; D359,483; D362,453;
D363,700; D363,918; D370,478; D383,124; D391,250; D405,077; D406,581; D414,171;
D414,172; D418,500; D419,548; D423,468; D424,035; D430,158; D430,159; D431,562;
D436,104.

Invention No. 55,358; 62,539; 69,060; 69,187 (Taiwan); No. 1,601,796; 1,907,875; 1,955,269 (Japan); European Patent 367,299; 414,281; 367,300; 367,298; UK 2,072,832; France 81/03938; Italy 1,138,713.
rev. 11/01

Introduction

Symbol Technologies' CRD6800 Lithium-Ion Cradle provides Lithium-Ion battery charging capabilities for up to four Series 68XX terminals.

About This Guide

This guide provides operation and installation information for the operator and system administrator.

Required Equipment

Verify that you have received the following:

- CRD 6800 Lithium-Ion cradle
- AC power supply
- DC cable
- AC cable

If any parts are damaged or missing, contact your nearest Service Center listed on the [backcover](#).



Parts of the Cradle

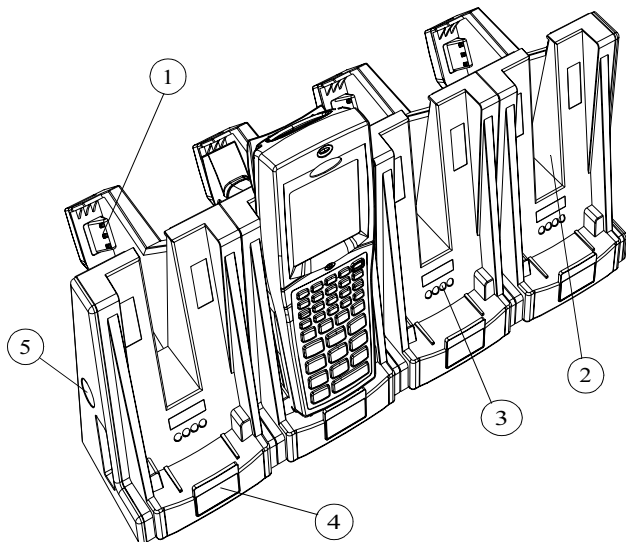

The numbers in the figure correspond to the descriptions below:

1. Battery charging contacts
2. Each terminal slot holds one Series 68XX terminal for recharging the Lithium-Ion battery.
3. Terminal contacts
4. Charging LED
5. DC power port - connects the power supply to the cradle

Connecting Power

Note: Use only Symbol-approved power supply p/n 50-14001-005 output rated 15Vdc and minimum 2.5A. The power supply is certified to EN60950 with SELV outputs.

Q u i c k R e f e r e n c e

Hinweis: Benutzen Sie nur eine Symbol Technologies genehmigt Stromversorgung p/n 50-14001-005 in den Ausgabe: 15Vdc und minimum 2.5A. Die Stromversorgung ist bescheinigt nach EN60950 mit SELV Ausgaben

1. Connect the power supply cord round plug to the power connector on the side of the cradle.
2. Connect the power supply cord AC plug to a standard electrical outlet. Upon power-up, the LEDs flash green-yellow-red, then dark in sequence from left (slot 1) to right (slot 4).

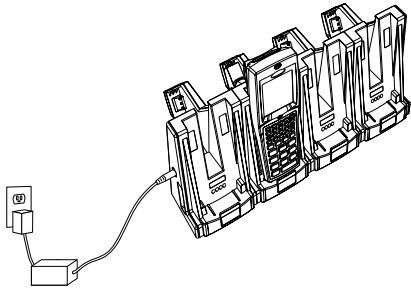

Inserting and Removing the Terminal

WARNING

DO NOT allow metal to short the exposed contacts on the toe of the battery while the battery is installed in an operating terminal. Doing so may cause the terminal to stop operating and lose contents.

If contacts are inadvertently shorted, remove and install the battery before restarting the terminal. If the terminal still does not power up, momentarily place the battery in a charger, either in this cradle with the terminal, or in a UBC charger.



To insert the terminal in the cradle:

1. Fit the bottom of the 68XX into the bottom of the cradle, ensuring the hand strap at the base of the battery falls away from the charging contacts.
2. Push the top of the 68XX toward the back of the cradle until it is firmly seated.
3. Place the terminal in SUSPEND mode with power management enabled.
4. The cradle's charge LED is solid or flashing green.

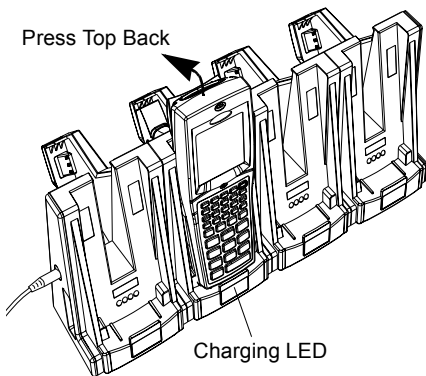

To remove the terminal from the cradle:

1. Pull the top of the 68XX to unlatch it.
2. Lift the 68XX out of the cradle.

Recharging the Battery in the 68XX

Note: Fully charge the battery before using the terminal.

After placing the terminal in the cradle, put the terminal in SUSPEND mode with power management enabled. Ensure that the terminal is awakened from SUSPEND infrequently if at all during charging, and that if awakened, the terminal automatically returns to SUSPEND within a few minutes.

The battery is automatically charged when the 68XX is properly inserted in the cradle.

1. Place the 68XX in the cradle. Place the terminal in SUSPEND mode with power management enabled. The LED indicator flashes green when charging a discharged battery, and remains solid green when the battery is fully charged. Refer to [LED Indicator on page 6](#).
2. Leave the 68XX up to 7 hours to charge a fully-discharged battery, or until the LED indicator is solid green.



LED Indicator

LED Indicator	Cradle
DARK	No battery or faulty battery in cradle bay
Slowly flashing GREEN (On for one second, off for one second)	Cradle is charging a very weak battery
Quickly flashing GREEN (On for 1/4 second or less, off for 1/4 second or less)	Cradle is charging the battery
Solid GREEN	Battery in bay is fully charged
Slowly flashing YELLOW (On for one second, off for one second)	Battery is too cold to charge
Quickly flashing YELLOW (On for 1/4 second or less, off for 1/4 second or less)	Battery is too hot to charge
Long RED (two seconds) followed by flashing RED	Self-test failure does not allow battery charging in this bay
Long DARK (two seconds) followed by flashing RED OR Any flashing sequence other than those described above	Battery in bay is faulty

Troubleshooting

Symptom	Possible Cause	Action
Indicators do not momentarily light when the cradle is powered up.	Cradle is not receiving power.	Make sure AC and DC power cables are securely connected and wall outlet is supplying power.
LED does not light or flash GREEN when terminal is inserted in cradle.	Terminal is not seated firmly in cradle.	Securely place terminal in cradle.
	There is no battery in the terminal.	Place discharged battery in terminal and place terminal in cradle.
LED flashes YELLOW once every two seconds.	The battery is too cold and the cradle does not permit charging.	Allow battery to warm to above 5°C. (Ambient temperature must be in the range of 5 to 45°C.) Charging starts automatically when battery temperature rises to within the range.
LED flashes YELLOW twice every second.	The battery is too hot and the cradle does not permit charging.	Allow battery to cool to below 40°C. (Ambient temperature must be in the range of 0 to 40°C.) Charging starts automatically when battery temperature lowers to within the range.
LED is DARK for two seconds, followed by flashing RED.	Battery failed.	You may try again to charge the battery by removing the terminal from and replacing it in the cradle, but the battery is probably faulty. Replace the battery.
LED is RED for two seconds, followed by flashing RED.	Cradle self test of its circuitry in that charging bay has failed so cradle prevents charging in that bay. Charging function is available in other bays.	You may remove and then apply power again to cradle by disconnecting and then connecting either AC or DC power cord. The symptom may recur when a terminal with a battery is placed in that bay. If it does, cradle is faulty and should be repaired.



Ergonomic Recommendations

Caution: In order to avoid or minimize the potential risk of ergonomic injury follow the recommendations below. Consult with your local Health & Safety Manager to ensure that you are meeting with your company's safety programs to prevent employee injury.

- Reduce or eliminate repetitive motion
- Maintain a natural position
- Reduce or eliminate excessive force
- Keep objects that are used frequently within easy reach
- Perform tasks at correct heights
- Reduce or eliminate vibration
- Reduce or eliminate direct pressure
- Provide adjustable workstations
- Provide adequate clearance
- Provide a suitable working environment
- Improve work procedures.

Regulatory Information

All Symbol devices are designed to be compliant with rules and regulations in locations they are sold and will be labeled as required.

Any changes or modifications to Symbol Technologies equipment, not expressly approved by Symbol Technologies, could void the user's authority to operate the equipment.



Marking and European Economic Area (EEA)

Statement of Compliance for non-radio devices

Symbol Technologies, Inc., hereby declares that this device is in compliance with all the applicable Directives, 89/336/EEC, 73/23/EEC. A Declaration of Conformity may be obtained from <http://www2.symbol.com/doc/>

Radio Frequency Interference Requirements

Note: This equipment has been tested and found to comply with the limits for a Class A digital device, pursuant to Part 15 of the FCC rules. These limits are designed to provide reasonable protection against harmful interference when the equipment is operated in commercial environment. This equipment generates, uses, and can radiate radio frequency energy and, if not installed and used in accordance with the instruction manual, may cause harmful interference to radio communications. Operation of this equipment in a residential area is likely to cause harmful interference in which case the user will be required to correct the interference at his own expense.

Radio Frequency Interference Requirements - Canada

This Class A digital apparatus complies with Canadian ICES-003.

Cet appareil numérique de la classe A est conforme à la norme NMB-003 du Canada.

Warranty

Symbol Technologies, Inc. ("Symbol") manufactures its hardware products in accordance with industry-standard practices. Symbol warrants that for a period of twelve (12) months from date of shipment, products will be free from defects in materials and workmanship.

This warranty is provided to the original owner only and is not transferable to any third party. It shall not apply to any product (i) which has been repaired or altered unless done or approved by Symbol, (ii) which has not been maintained in accordance with any operating or handling instructions supplied by Symbol, (iii) which has been subjected to unusual physical or electrical stress, misuse, abuse, power shortage, negligence or accident or (iv) which has been used other than in accordance with the product operating and handling instructions. Preventive maintenance is the responsibility of customer and is not covered under this warranty.

Wear items and accessories having a Symbol serial number will carry a 90-day limited warranty.

Non-serialized items will carry a 30-day limited warranty.

Warranty Coverage and Procedure

During the warranty period, Symbol will repair or replace defective products returned to Symbol's manufacturing plant in the US. For warranty service in North America, call the Symbol Support Center at 1-800-653-5350. International customers should contact the local Symbol office or support center. If warranty service is required, Symbol will issue a Return Material Authorization Number. Products must be shipped in the original or comparable packaging, shipping and insurance charges prepaid. Symbol will ship the repaired or replacement product freight and insurance prepaid in North America. Shipments from the US or other locations will be made F.O.B. Symbol's manufacturing plant.

Symbol will use new or refurbished parts at its discretion and will own all parts removed from repaired products. Customer will pay for the replacement product in case it does not return the replaced product to Symbol within 3 days of receipt of the replacement product. The process for return and customer's charges will be in accordance with Symbol's Exchange Policy in effect at the time of the exchange.

Customer accepts full responsibility for its software and data including the appropriate backup thereof.

Repair or replacement of a product during warranty will not extend the original warranty term.

Symbol's Customer Service organization offers an array of service plans, such as on-site, depot, or phone support, that can be implemented to meet customer's special operational requirements and are available at a substantial discount during warranty period.

General

Except for the warranties stated above, Symbol disclaims all warranties, express or implied, on products furnished hereunder, including without limitation implied warranties of merchantability and fitness for a particular purpose. The stated express warranties are in lieu of all obligations or liabilities on part of Symbol for damages, including without limitation, special, indirect, or consequential damages arising out of or in connection with the use or performance of the product.

Seller's liability for damages to buyer or others resulting from the use of any product, shall in no way exceed the purchase price of said product, except in instances of injury to persons or property.

Some states (or jurisdictions) do not allow the exclusion or limitation of incidental or consequential damages, so the preceding exclusion or limitation may not apply to you.

Service Information

Before you use the unit, it must be configured to operate in your facility's network and run your applications.

If you have a problem running your unit or using your equipment, contact your facility's Technical or Systems Support. If there is a problem with the equipment, they will contact the Symbol Support Center:

United States ¹	1-800-653-5350 1-631-738-2400	Canada	905-629-7226
United Kingdom	0800 328 2424	Asia/Pacific	337-6588
Australia	1-800-672-906	Austria/Österreich	1-505-5794
Denmark/Danmark	7020-1718	Finland/Suomi	9 5407 580
France	01-40-96-52-21	Germany/Deutschland	6074-49020
Italy/Italia	2-484441	Mexico/México	5-520-1835
Netherlands/Nederland	315-271700	Norway/Norge	66810600
South Africa	11-4405668	Spain/España	+913244000
Sweden/Sverige	84452900		
Latin America Sales Support	1-800-347-0178 Inside US +1-561-483-1275 Outside US		
Europe/Mid-East Distributor Operations	Contact local distributor or call +44 118 945 7360		

¹Customer support is available 24 hours a day, 7 days a week.

For the latest version of this guide go to: <http://www.symbol.com/manuals>.



72-54434-01
Revision A — February 2002