



W 4-2 series: Small but powerful

	Photoelectric proximity switches BGS
	Photoelectric reflex switches
	Through-beam photoelectric switches



beverage and tobacco industries, the electronics sector and packaging machines.

The WT 4-2 photoelectric proximity switch can be adjusted to scanning ranges between 4 and 130 mm. Whatever the individual application, the sensor allows the appropriate background suppression to be selected.

WL 4-2 is the name of the photoelectric reflex switch in this series. It can detect objects reliably at a distance of up to 2.8 metres.

The WL 4G-2 glass photoelectric switch has been specially developed for use in the packaging and beverage industries. It is easier to install, simpler to calibrate and has a greater scanning range than fibre-optic sensors. If a polarising filter is used, it also allows reflective objects to be detected, e.g. partially printed or aluminised foils.

The WS/WE 4-2 through-beam photoelectric switch has a scanning range of 4 metres. Like the other sensors in this series it uses visible light which makes adjustment and alignment of the sensor during commissioning much easier.

As small as a sugar cube and as powerful as a "large" photoelectric switch – these are the two principal features of the W 4-2 photoelectric switch series. They are used in particularly narrow locations and where only limited mounting space is available. Insensitivity to ambient light (e.g. from HF or flashing warning lamps) and a high level of functional reliability if devices are installed opposite each other are particularly important for trouble-free operation. Sensor housings are made of fully welded plastic (ABS). Temperature variations between -40 and $+60$ °C, splash-water and dust do not reduce the reliability of object detection. Suitable areas of application are the food-processing,

► The presence of small containers in a lifting unit is determined by a WT 4-2.

▼ Photoelectric reflex switches controlling the transport systems used in printed circuit board production.

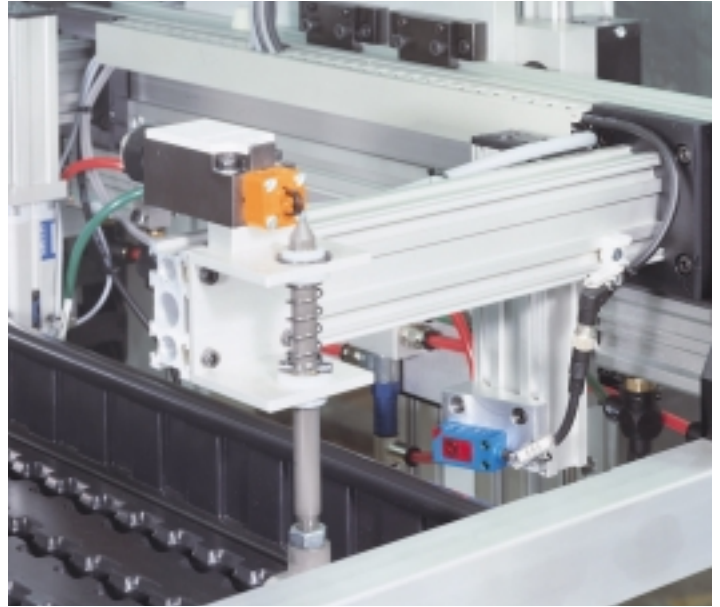
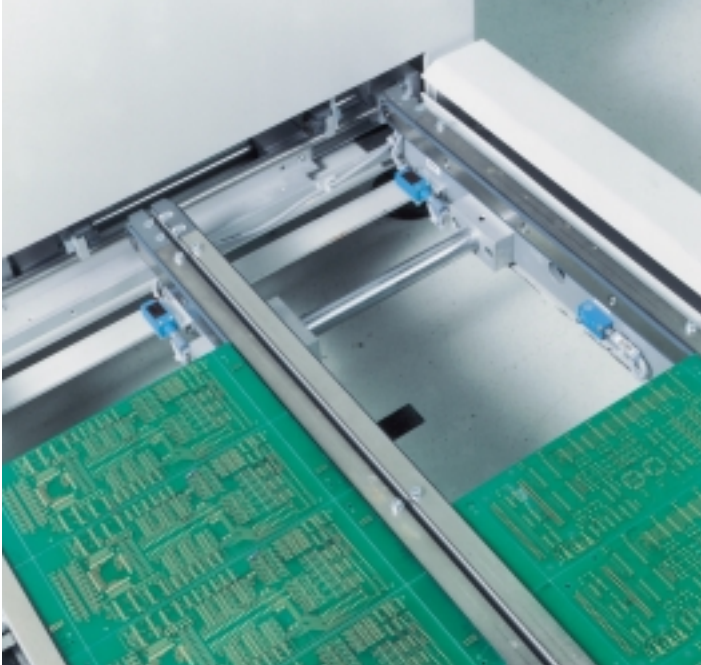

▲ The fully automatic soldering robot springs into action as soon as the WT 4-2 photoelectric proximity switches have detected the next workpiece – e.g. a photoelectric switch.

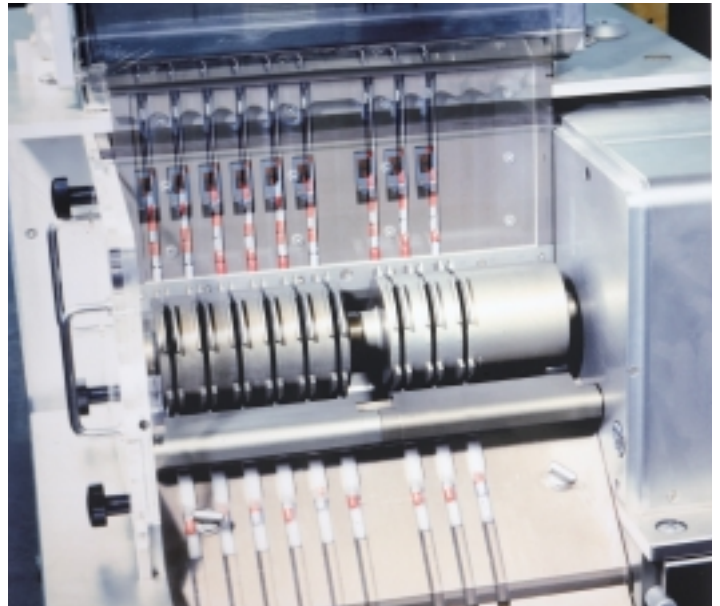

▲ In the pharmaceutical industry: WT 4-2 photoelectric proximity switches are used to detect individual pills in a precision balance.

 **Scanning distance**
4 ... 130 mm

Photoelectric proximity switches

- Adjustable background suppression
- Insensitive to ambient light sources (HF lamps, flashing warning lamps)
- Reliable operation if devices are installed opposite each other
- Permissible operating temperature - 40 °C...+ 60 °C
- Rapid response time

Dimensional drawing

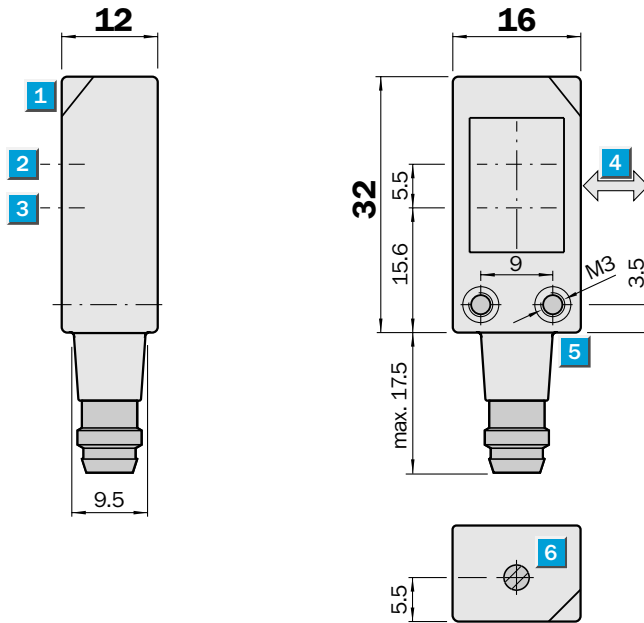

Adjustments possible

All types

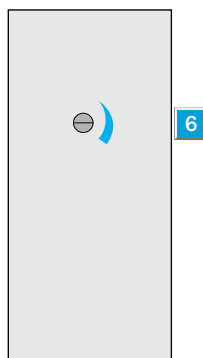

- 1 LED signal strength indicator
- 2 Optical axis, receiver
- 3 Optical axis, sender
- 4 Standard direction of the material being scanned
- 5 M 3 threaded mounting hole
- 6 Scanning distance adjustment

Connection types

WT 4-2P 132	WT 4-2P 330	WT 4-2P 430	WT 4-2P 331
WT 4-2N 132	WT 4-2N 330		WT 4-2N 331

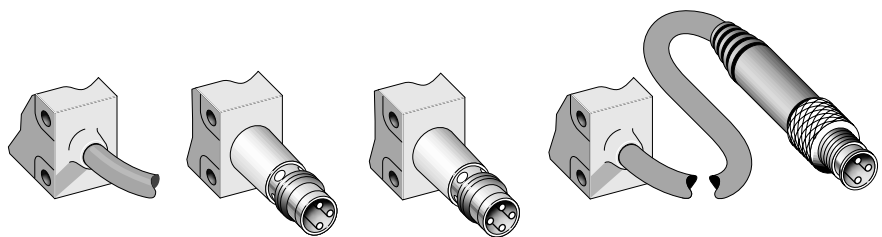

3 x 0.25 mm ²	3-pin, M 8	4-pin, M 8	3-pin, M 8
--------------------------	------------	------------	------------

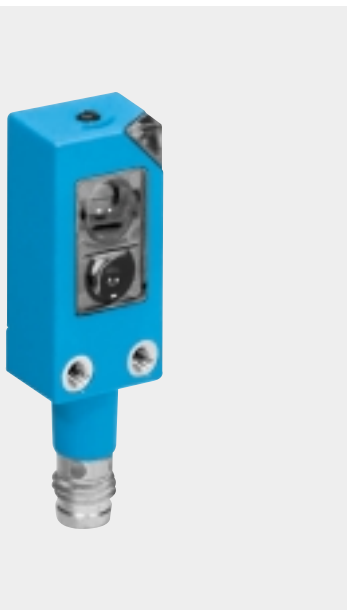
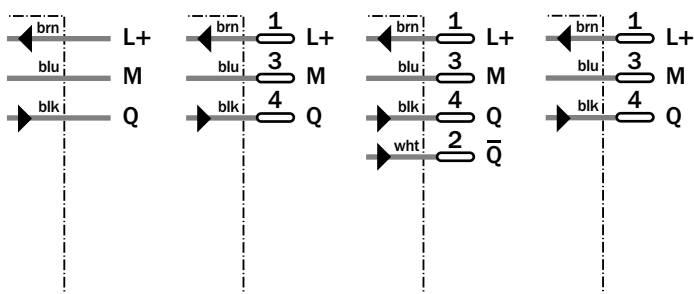

Accessories	page
Cable receptacles	496

Technical data		WT 4-2	P 132	P 330	P 331	N 132	N 330	N 331	P 430
Scanning distance	4...130 mm, adjustable								
Background suppression	adjustable from 20 mm								
Light source¹⁾, light type	LED, red light								
Light spot diameter	3 mm at 50 mm								
Supply voltage V_S	10...30 V DC ²⁾								
Ripple ³⁾	5 V_{SS}								
Current consumption ⁴⁾	< 20 mA								
Switching outputs	PNP, Q NPN, Q PNP, Q and \bar{Q}								
Switching mode	Light-switching Dark-switching								
Output current I_A max.	100 mA								
PNP; signal voltage HIGH	$V_S - (< 2.5 V)$								
PNP; signal voltage LOW	Approx. 0 V								
NPN; signal voltage HIGH	Approx. V_S								
NPN; signal voltage LOW	< 1.5 V								
Response time ⁵⁾	< 500 μs								
Max. switching frequency ⁶⁾	1000/s								
Connection types	Cable ⁷⁾ , 2 m Plug M 8 Cable ⁷⁾ , 100 mm, with plug								
VDE protection class	III								
Circuit protection⁸⁾	A, B, C								
Enclosure rating⁹⁾	IP 67								
Ambient temperature T_A	Operation -40 °C...+60 °C Storage -40 °C...+75 °C								
Weight	Approx. 20 g								
Housing material	PC, polycarbonate								

- 1) Average service life 100,000 h where $T_A = +25\text{ °C}$
- 2) Limit values
- 3) May not exceed or fall short of V_S tolerances

- 4) Without load
- 5) Signal transit time with resistive load
- 6) With light/dark ratio 1:1
- 7) Do not bend below 0 °C

- 8) A = V_S connections reverse-polarity protected
B = Output Q and \bar{Q} short-circuit protected
C = Interference pulse suppression

- 9) IP 67: with screw-in cable receptacles
IP 65: with plug-in cable receptacles

Scanning distance

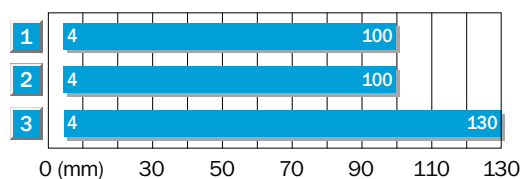

- 1 Scanning distance on black, 6 % remission
- 2 Scanning distance on grey, 18 % remission
- 3 Scanning distance on white, 90 % remission

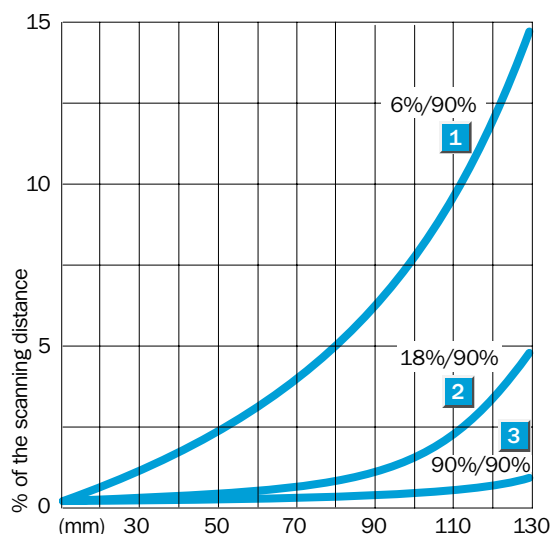

Order information

Type	Part no.
WT 4-2P 132	1 015 150
WT 4-2P 330	1 015 143
WT 4-2P 331	1 015 145
WT 4-2N 132	1 012 874
WT 4-2N 330	1 012 920
WT 4-2N 331	1 015 147
WT 4-2P 430	1 015 957

 **Scanning distance**
4 ... 130 mm

Photoelectric proximity switches

- Adjustable background suppression
- Insensitive to ambient light sources (HF lamps, flashing warning lamps)
- Reliable operation if devices are installed opposite each other
- Permissible operating temperature - 40 °C...+ 60 °C
- Rapid response time

Dimensional drawing

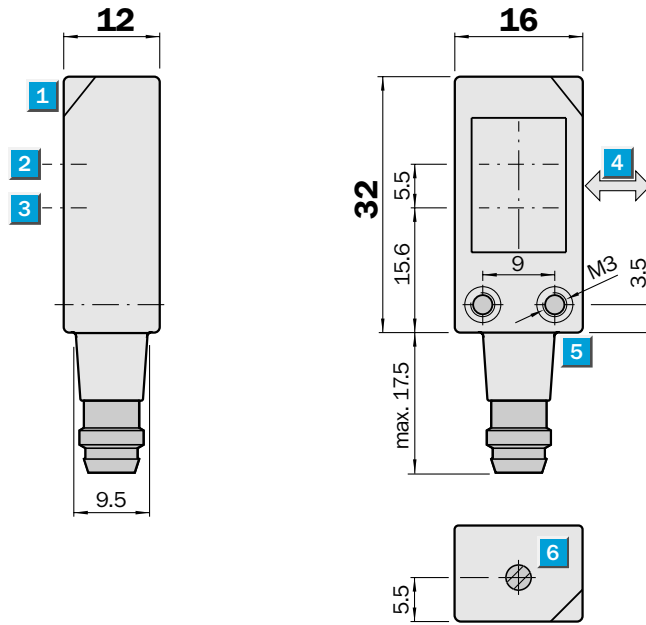

Adjustments possible

All types

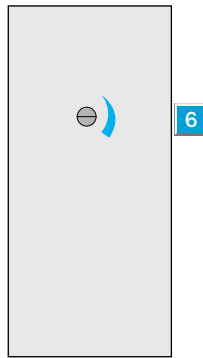

- 1 LED signal strength indicator
- 2 Optical axis, receiver
- 3 Optical axis, sender
- 4 Standard direction of the material being scanned
- 5 M 3 threaded mounting hole
- 6 Scanning distance adjustment

Connection types

WT 4-2E 132	WT 4-2E 330	WT 4-2E 331
WT 4-2F 132	WT 4-2F 330	WT 4-2F 331

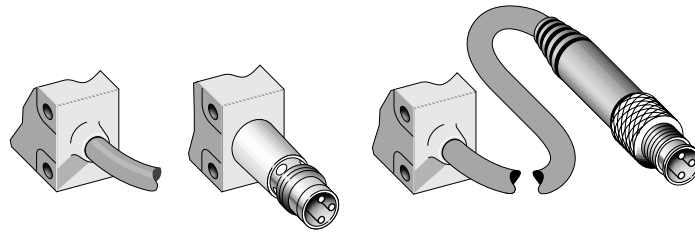

3 x 0.25 mm²

3-pin, M 8

3-pin, M 8

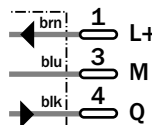
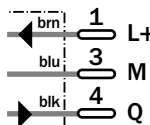
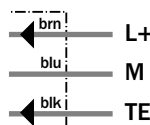

Accessories	page
Cable receptacles	496

Technical data		WT 4-2	E 132	E 330	E 331	F 132	F 330	F 331				
Scanning distance	4...130 mm, adjustable											
Background suppression	adjustable from 20 mm											
Light source¹⁾, light type	LED, red light											
Light spot diameter	3 mm at 50 mm											
Supply voltage V_S	10...30 V DC ²⁾											
Ripple ³⁾	5 V_{SS}											
Current consumption ⁴⁾	< 20 mA											
Switching outputs	PNP, Q											
	NPN, Q											
Switching mode	Dark-switching											
Output current I_A max.	100 mA											
PNP; signal voltage HIGH	$V_S - (< 2.5 V)$											
PNP; signal voltage LOW	Approx. 0 V											
NPN; signal voltage HIGH	Approx. V_S											
NPN; signal voltage LOW	< 1.5 V											
Response time ⁵⁾	< 500 μs											
Max. switching frequency ⁶⁾	1000/s											
Connection types	Cable ⁷⁾ , 2 m											
	Plug M 8											
	Cable ⁷⁾ , 100 mm, with plug											
VDE protection class	III											
Circuit protection⁸⁾	A, B, C											
Enclosure rating⁹⁾	IP 67											
Ambient temperature T_A	Operation - 40 °C...+ 60 °C											
	Storage - 40 °C...+ 75 °C											
Weight	Approx. 20 g											
Housing material	PC, polycarbonate											

- 1) Average service life 100,000 h where $T_A = + 25 °C$
- 2) Limit values
- 3) May not exceed or fall short of V_S tolerances
- 4) Without load
- 5) Signal transit time with resistive load
- 6) With light/dark ratio 1:1
- 7) Do not bend below 0 °C
- 8) A = V_S connections reverse-polarity protected
B = Output Q short-circuit protected
C = Interference pulse suppression
- 9) IP 67: with screw-in cable receptacles
IP 65: with plug-in cable receptacles

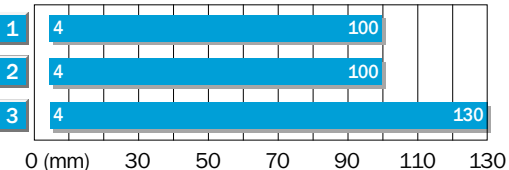
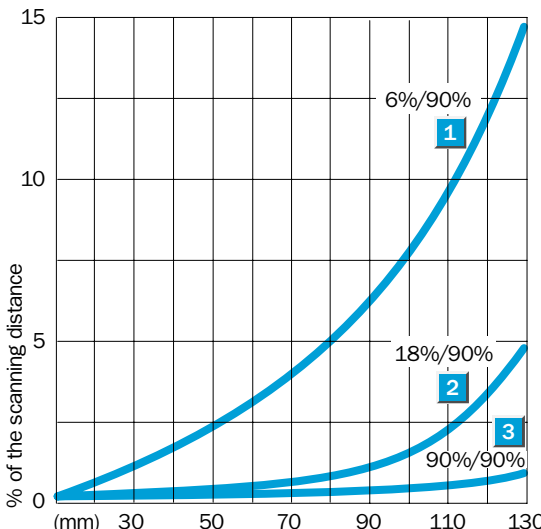
Scanning distance		Order information														
 <p>1 Scanning distance on black, 6 % remission</p> <p>2 Scanning distance on grey, 18 % remission</p> <p>3 Scanning distance on white, 90 % remission</p>		<table border="1"> <thead> <tr> <th>Type</th> <th>Part no.</th> </tr> </thead> <tbody> <tr><td>WT 4-2E 132</td><td>1 012 875</td></tr> <tr><td>WT 4-2E 330</td><td>1 013 787</td></tr> <tr><td>WT 4-2E 331</td><td>1 015 148</td></tr> <tr><td>WT 4-2F 132</td><td>1 012 873</td></tr> <tr><td>WT 4-2F 330</td><td>1 015 144</td></tr> <tr><td>WT 4-2F 331</td><td>1 015 146</td></tr> </tbody> </table>	Type	Part no.	WT 4-2E 132	1 012 875	WT 4-2E 330	1 013 787	WT 4-2E 331	1 015 148	WT 4-2F 132	1 012 873	WT 4-2F 330	1 015 144	WT 4-2F 331	1 015 146
Type	Part no.															
WT 4-2E 132	1 012 875															
WT 4-2E 330	1 013 787															
WT 4-2E 331	1 015 148															
WT 4-2F 132	1 012 873															
WT 4-2F 330	1 015 144															
WT 4-2F 331	1 015 146															

Scanning range
2.8 m

Photoelectric reflex switches

- Insensitive to ambient light sources (HF lamps, flashing warning lamps)
- Reliable operation if devices are installed opposite each other
- Permissible operating temperature - 40 °C...+ 60 °C
- Rapid response time

Dimensional drawing

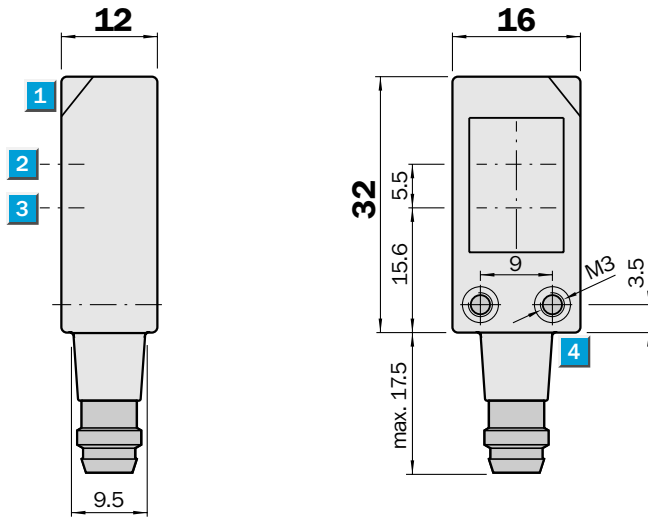

- 1 LED signal strength indicator
- 2 Optical axis, receiver
- 3 Optical axis, sender
- 4 M 3 threaded mounting hole



Connection types

WL 4-2P 132	WL 4-2P 330	WL 4-2P 430	WL 4-2P 331
WL 4-2N 132	WL 4-2N 330		WL 4-2N 331

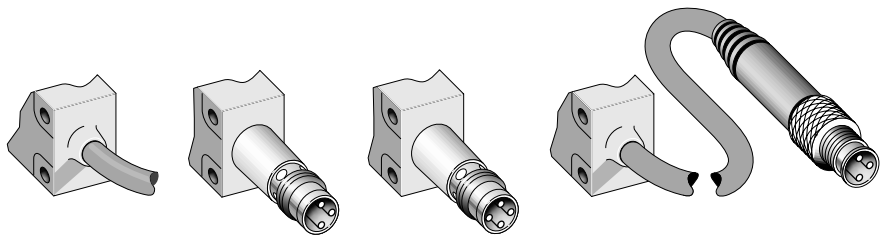

3 x 0.25 mm ²	3-pin, M 8	4-pin, M 8	3-pin, M 8
--------------------------	------------	------------	------------

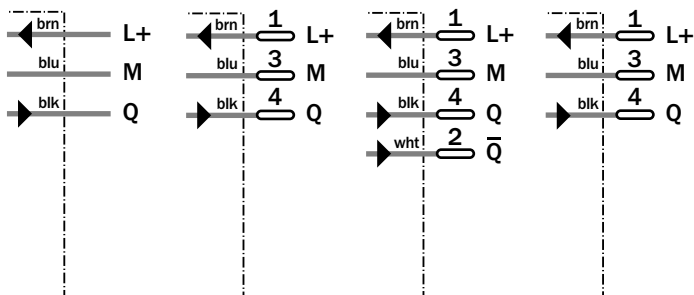

Accessories	page
Cable receptacles	496
Reflectors	520

Technical data WL 4-2 P 132 P 330 P 331 N 132 N 330 N 331 P 430

Scanning range , max. typical/ on reflector	2.8 m/PL 80 A								
Light source¹⁾, light type	LED, red light								
Light spot diameter	230 mm at 1.5 m								
At focal point	Approx. 3.5 mm at 90 mm								
Supply voltage V_S	10...30 V DC ²⁾								
Ripple ³⁾	5 V_{SS}								
Current consumption ⁴⁾	< 20 mA								
Switching outputs	PNP, Q NPN, Q PNP, Q and \bar{Q}								
Switching mode	Dark-switching Light-switching								
Output current I_A max.	100 mA								
PNP; signal voltage HIGH	$V_S - (< 2.5 V)$								
PNP; signal voltage LOW	Approx. 0 V								
NPN; signal voltage HIGH	Approx. V_S								
NPN; signal voltage LOW	< 1.5 V								
Response time ⁵⁾	< 500 μs								
Max. switching frequency ⁶⁾	1000/s								

Connection types	Cable ⁷⁾ , 2 m Plug M 8 Cable ⁷⁾ , 100 mm, with plug								
-------------------------	--	--	--	--	--	--	--	--	--

VDE protection class	III								
Circuit protection⁸⁾	A, B, C								
Enclosure rating⁹⁾	IP 67								
Ambient temperature T_A	Operation -40 °C...+60 °C Storage -40 °C...+75 °C								
Weight	Approx. 20 g								
Polarising filter									
Housing material	PC, polycarbonate								

- 1) Average service life 100,000 h where $T_A = +25\text{ °C}$
- 2) Limit values
- 3) May not exceed or fall short of V_S tolerances
- 4) Without load
- 5) Signal transit time with resistive load
- 6) With light/dark ratio 1:1
- 7) Do not bend below 0 °C
- 8) A = V_S connections reverse-polarity protected
B = Output Q and \bar{Q} short-circuit protected
C = Interference pulse suppression
- 9) IP 67: with screw-in cable receptacles
IP 65: with plug-in cable receptacles

Operating range and operating reserve

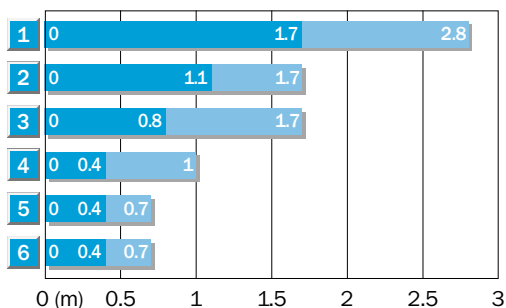

Reflector type	Operating range
1 PL 80 A	0...1.7 m
2 PL 50 A	0...1.1 m
3 PL 40 A	0...0.8 m
4 PL 30 A	0...0.4 m
5 PL 20 A	0...0.4 m
6 Reflective tape	35...400 mm
Diamond Grade	

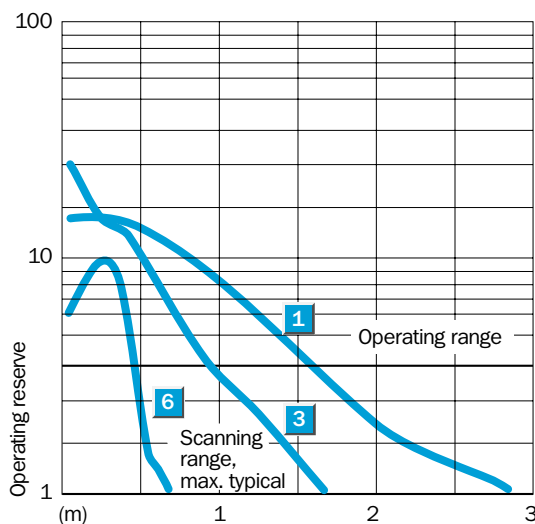

Order information

Type	Part no.
WL 4-2P 132	1 015 767
WL 4-2P 330	1 015 763
WL 4-2P 331	1 015 759
WL 4-2N 132	1 015 769
WL 4-2N 330	1 015 765
WL 4-2N 331	1 015 761
WL 4-2P 430	1 015 958

 **Scanning range**
2.8 m

Photoelectric reflex switches

- Insensitive to ambient light sources (HF lamps, flashing warning lamps)
- Reliable operation if devices are installed opposite each other
- Permissible operating temperature - 40 °C...+ 60 °C
- Rapid response time

Dimensional drawing

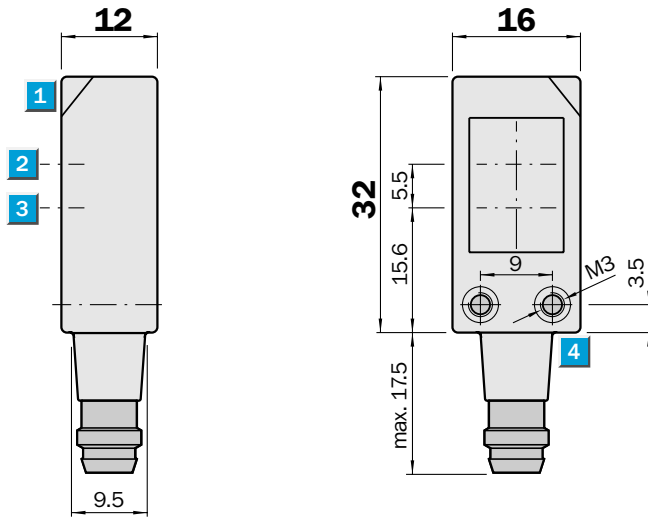

- 1 LED signal strength indicator
- 2 Optical axis, receiver
- 3 Optical axis, sender
- 4 M 3 threaded mounting hole



Connection types

WL 4-2E 132	WL 4-2E 330	WL 4-2E 331
WL 4-2F 132	WL 4-2F 330	WL 4-2F 331

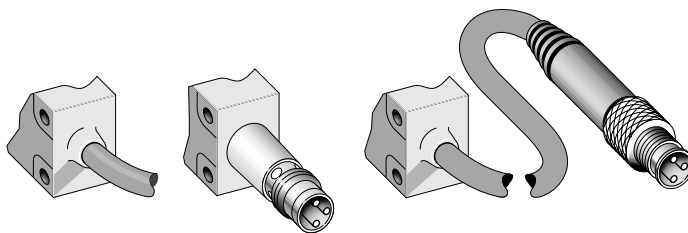

3 x 0.25 mm²

3-pin, M 8

3-pin, M 8

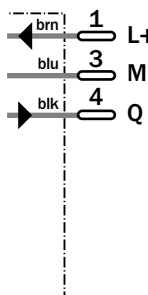
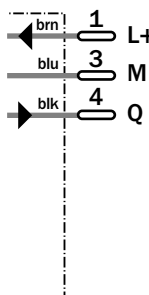
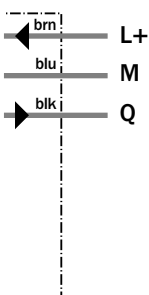

Accessories	page
Cable receptacles	496
Reflectors	520

Technical data		WL 4-2	E 132	E 330	E 331	F 132	F 330	F 331				
Scanning range , max. typical/ on reflector	2.8 m/PL 80 A											
Light source¹⁾, light type	LED, red light											
Light spot diameter	230 mm at 1.5 m											
At focal point	Approx. 3.5 mm at 90 mm											
Supply voltage V_S	10...30 V DC ²⁾											
Ripple ³⁾	5 V_{SS}											
Current consumption ⁴⁾	< 20 mA											
Switching outputs	PNP, Q											
	NPN, Q											
Switching mode	Dark-switching											
Output current I_A max.	100 mA											
PNP; signal voltage HIGH	$V_S - (< 2.5 V)$											
PNP; signal voltage LOW	Approx. 0 V											
NPN; signal voltage HIGH	Approx. V_S											
NPN; signal voltage LOW	< 1.5 V											
Response time ⁵⁾	< 500 μs											
Max. switching frequency ⁶⁾	1000/s											
Connection types	Cable ⁷⁾ , 2 m											
	Plug M 8											
	Cable ⁷⁾ , 100 mm, with plug											
VDE protection class	III											
Circuit protection⁸⁾	A, B, C											
Enclosure rating⁹⁾	IP 67											
Ambient temperature T_A	Operation -40 °C...+60 °C											
	Storage -40 °C...+75 °C											
Weight	Approx. 20 g											
Polarising filter												
Housing material	PC, polycarbonate											

- 1) Average service life 100,000 h where $T_A = +25\text{ °C}$
- 2) Limit values
- 3) May not exceed or fall short of V_S tolerances
- 4) Without load
- 5) Signal transit time with resistive load
- 6) With light/dark ratio 1:1
- 7) Do not bend below 0 °C
- 8) A = V_S connections reverse-polarity protected
B = Output Q short-circuit protected
C = Interference pulse suppression
- 9) IP 67: with screw-in cable receptacles
IP 65: with plug-in cable receptacles

Operating range and operating reserve

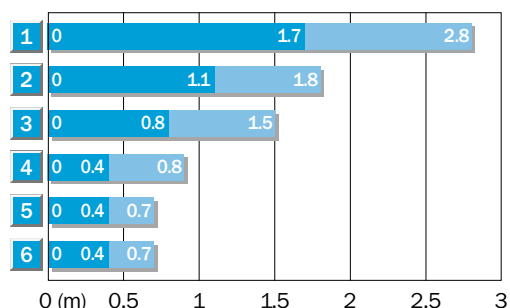

Reflector type	Operating range
1 PL 80 A	0...1.7 m
2 PL 50 A	0...1.1 m
3 PL 40 A	0...0.8 m
4 PL 30 A	0...0.4 m
5 PL 20 A	0...0.4 m
6 Reflective tape	35...400 mm
Diamond Grade	

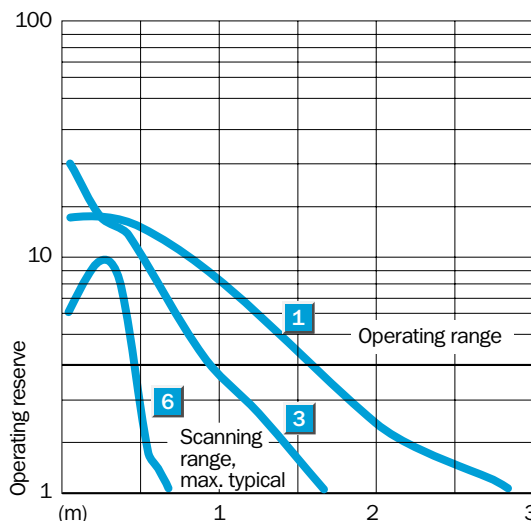

Order information

Type	Part no.
WL 4-2E 132	1 015 770
WL 4-2E 330	1 015 766
WL 4-2E 331	1 015 762
WL 4-2F 132	1 015 768
WL 4-2F 330	1 015 764
WL 4-2F 331	1 015 760

 **Scanning range**
1.6 m

Photoelectric reflex switches

- Detects glass and transparent films
- Insensitive to ambient light sources (HF lamps, flashing warning lamps)
- Reliable operation if devices are installed opposite each other
- Permissible operating temperature - 40 °C...+ 60 °C
- Rapid response time

Dimensional drawing

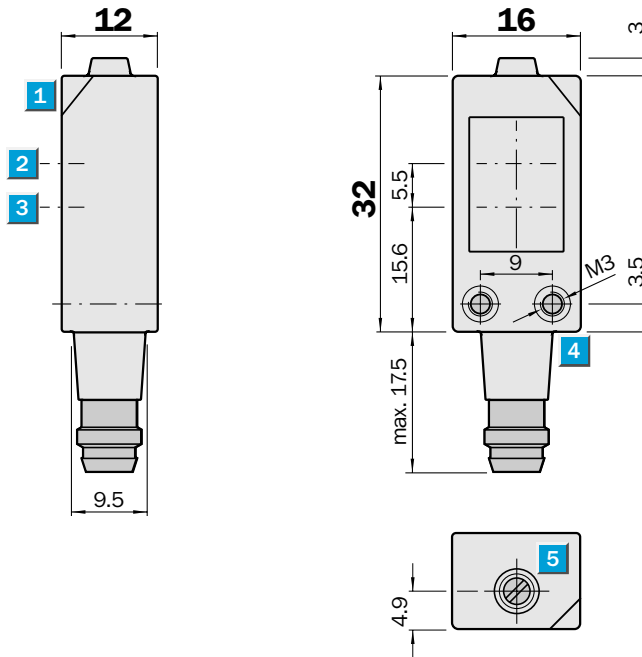

Adjustments possible

WL 4G-2F 330

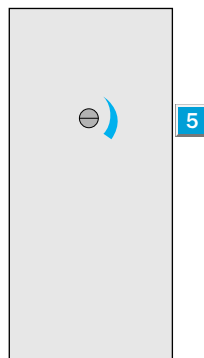

- 1 LED signal strength indicator
- 2 Optical axis, receiver
- 3 Optical axis, sender
- 4 M 3 threaded mounting hole
- 5 Sensitivity control

Connection type

WL 4G-2F 330

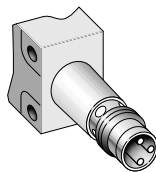

3-pin, M 8

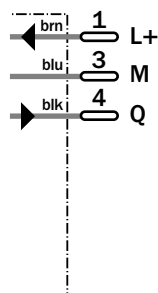

Accessories	page
Cable receptacles	496
Reflectors	520

Technical data		WL 4G-2	F 330								
Scanning range , max. typical/ on reflector	1.6 m/PL 80 A										
Sensitivity	Adjustable										
Light source¹⁾, light type	LED, red light										
Light spot diameter	230 mm at 1.5 m										
Supply voltage V_S	10...30 V DC ²⁾										
Ripple ³⁾	5 V_{SS}										
Current consumption ⁴⁾	< 20 mA										
Switching outputs	PNP, Q										
Switching mode	Dark-switching										
Output current I_A max.	100 mA										
PNP; signal voltage HIGH	$V_S - (< 2.5 V)$										
PNP; signal voltage LOW	Approx. 0 V										
Response time ⁵⁾	< 500 μs										
Max. switching frequency ⁶⁾	1000/s										
Connection type	Plug M 8										
VDE protection class	ⓘ										
Circuit protection⁷⁾	A, B, C										
Enclosure rating⁸⁾	IP 67										
Ambient temperature T_A	Operation - 40 °C...+ 60 °C Storage - 40 °C...+ 75 °C										
Weight	Approx. 20 g										
Polarising filter											
Housing material	PC, polycarbonate										

- 1) Average service life 100,000 h where $T_A = + 25 °C$
- 2) Limit values
- 3) May not exceed or fall short of V_S tolerances
- 4) Without load
- 5) Signal transit time with resistive load
- 6) With light/dark ratio 1:1
- 7) A = V_S connections reverse-polarity protected
B = Output Q short-circuit protected
C = Interference pulse suppression
- 8) IP 67: with screw-in cable receptacles
IP 65: with plug-in cable receptacles

Operating range and transmission attenuation

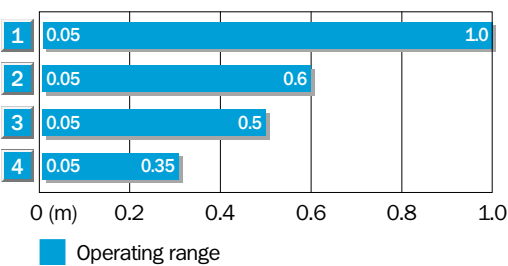

Reflector type	Operating range
1 PL 80 A	0.05...1.0 m
2 PL 50 A	0.05...0.6 m
3 PL 40 A	0.05...0.5 m
4 PL 30 A	0.05...0.35 m

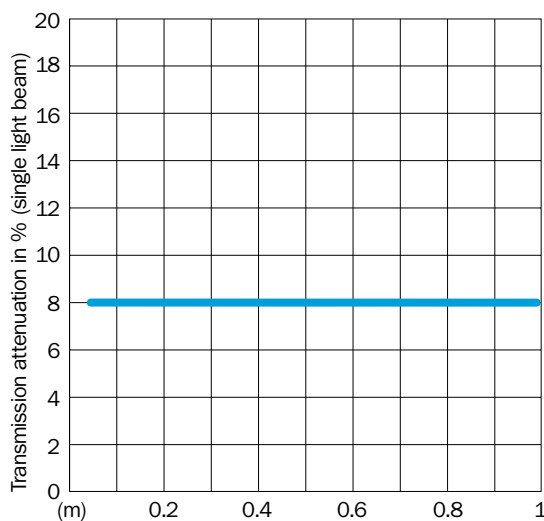

Order information

Type	Part no.
WL 4G-2F 330	1 016 209

 **Scanning range**
4 m

Through-beam photoelectric switches

- Insensitive to ambient light sources (HF lamps, flashing warning lamps)
- Permissible operating temperature - 40 °C...+ 60 °C
- Rapid response time
- Test input for system diagnosis

Dimensional drawing

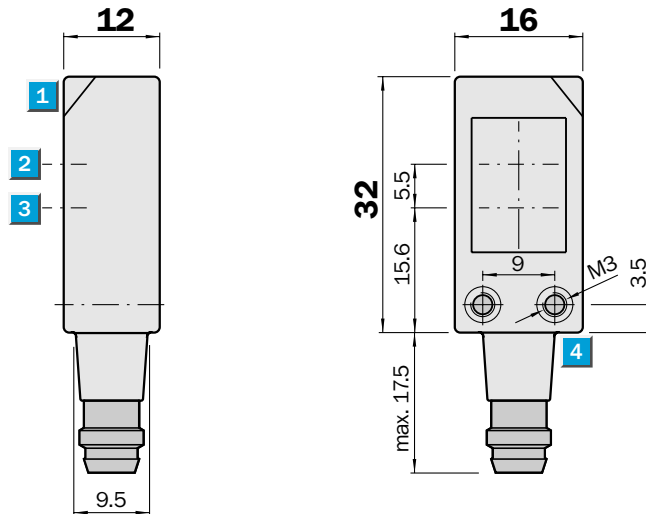

- 1 LED signal strength indicator
- 2 Optical axis, receiver
- 3 Optical axis, sender
- 4 M 3 threaded mounting hole



Connection types

WS/WE 4-2P 132	WS/WE 4-2P 330	WS/WE 4-2P 331
WS/WE 4-2N 132	WS/WE 4-2N 330	WS/WE 4-2N 331

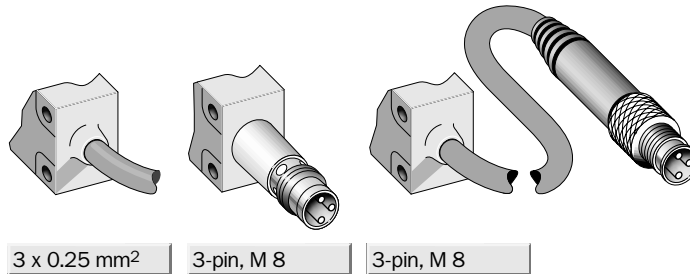

3 x 0.25 mm²

3-pin, M 8

3-pin, M 8

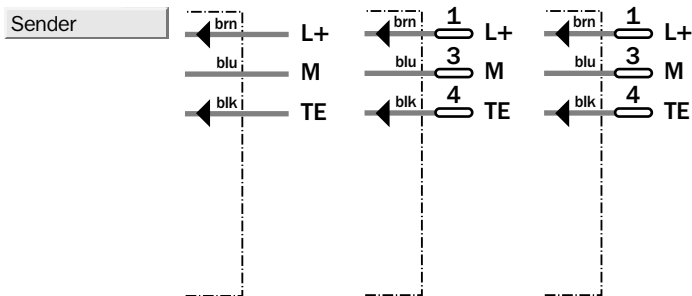

Accessories	page
Cable receptacles	496

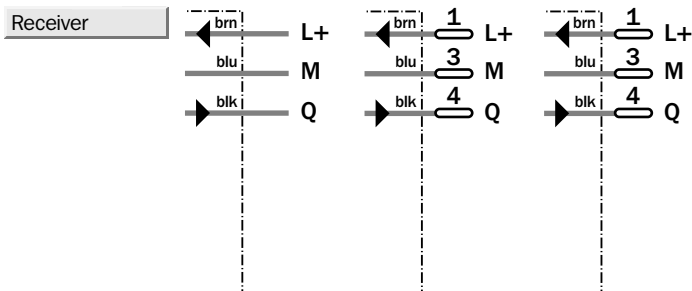

Technical data		WS/WE 4-2	P 132	P 330	P 331	N 132	N 330	N 331				
Scanning range , max. typical	0...4 m											
Light source¹⁾, light type	LED, red light											
Light spot diameter	Approx. 340 mm at 2 m											
Angle of dispersion	Approx. 12°											
Supply voltage V_S	10...30 V DC ²⁾											
Ripple ³⁾	5 V_{SS}											
Current consumption ⁴⁾	< 50 mA											
sender	< 20 mA											
receiver	< 30 mA											
Switching outputs	PNP, Q											
	NPN, Q											
Switching mode	Light-switching											
Output current I_A max.	100 mA											
PNP; signal voltage HIGH	$V_S - (< 2.5 V)$											
PNP; signal voltage LOW	Approx. 0 V											
NPN; signal voltage HIGH	Approx. V_S											
NPN; signal voltage LOW	< 1.5 V											
Response time ⁵⁾	< 500 μs											
Max. switching frequency ⁶⁾	1000/s											
Test input "TE" Sender OFF	TE to 0 V											
Connection types	Cable ⁷⁾ , 2 m											
	Plug M 8											
	Cable ⁷⁾ , 100 mm, with plug											
VDE protection class	ⓘ											
Circuit protection⁸⁾	A, B, C											
Enclosure rating⁹⁾	IP 67											
Ambient temperature T_A	Operation - 40 °C...+ 60 °C											
	Storage - 40 °C...+ 75 °C											
Weight	Approx. 20 g											
Housing material	PC, polycarbonate											

- 1) Average service life 100,000 h where $T_A = + 25 °C$
- 2) Limit values
- 3) May not exceed or fall short of V_S tolerances

- 4) Without load
- 5) Signal transit time with resistive load
- 6) With light/dark ratio 1:1
- 7) Do not bend below 0 °C

- 8) A = V_S connections reverse-polarity protected
- B = Output Q short-circuit protected
- C = Interference pulse suppression

- 9) IP 67: with screw-in cable receptacles
- IP 65: with plug-in cable receptacles

Operating range and operating reserve

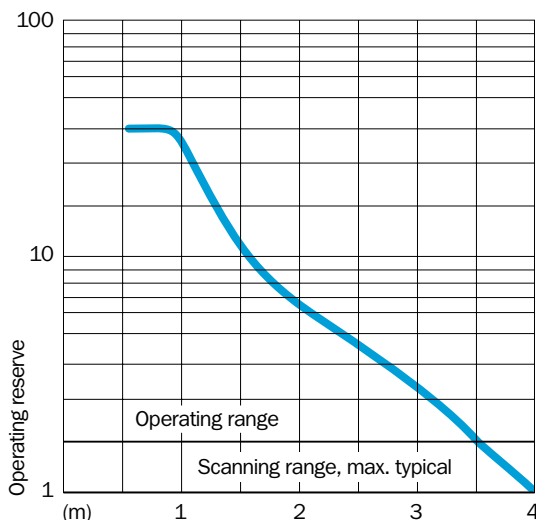
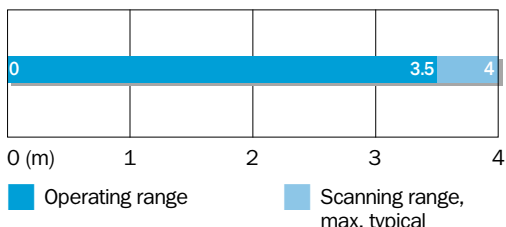

Order information

Type	Part no.
WS/WE 4-2P 132	1 015 779
WS/WE 4-2P 330	1 015 775
WS/WE 4-2P 331	1 015 771
WS/WE 4-2N 132	1 015 781
WS/WE 4-2N 330	1 015 777
WS/WE 4-2N 331	1 015 773

 **Scanning range**
4 m

Through-beam photoelectric switches

- Insensitive to ambient light sources (HF lamps, flashing warning lamps)
- Permissible operating temperature - 40 °C...+ 60 °C
- Rapid response time
- Test input for system diagnosis

Dimensional drawing

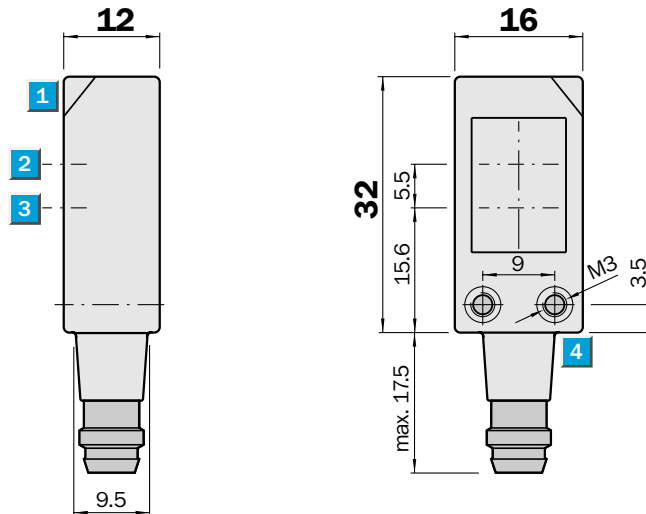

- 1 LED signal strength indicator
- 2 Optical axis, receiver
- 3 Optical axis, sender
- 4 M 3 threaded mounting hole



Connection types

WS/WE 4-2E 132	WS/WE 4-2E 330	WS/WE 4-2E 331
WS/WE 4-2F 132	WS/WE 4-2F 330	WS/WE 4-2F 331

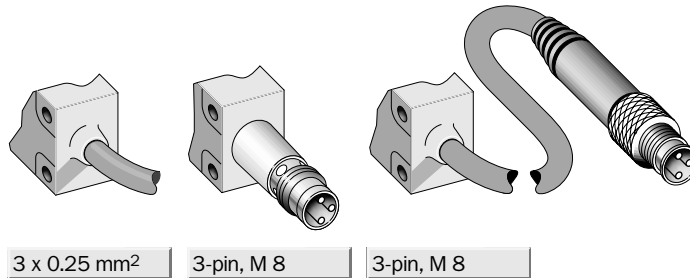

3 x 0.25 mm²

3-pin, M 8

3-pin, M 8

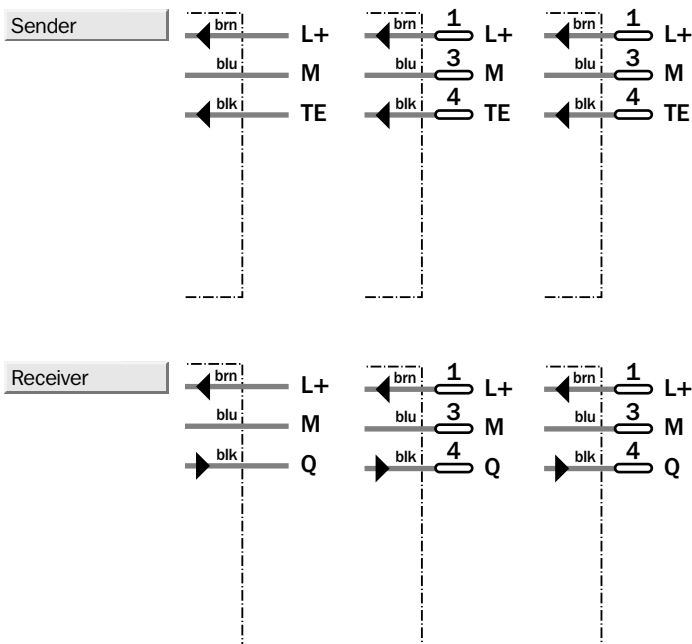

Accessories	page
Cable receptacles	496

Technical data		WS/WE 4-2	E 132	E 330	E 331	F 132	F 330	F 331
Scanning range , max. typical	0...4 m							
Light source¹⁾, light type	LED, red light							
Light spot diameter	Approx. 340 mm at 2 m							
Angle of dispersion	Approx. 12°							
Supply voltage V_S	10...30 V DC ²⁾							
Ripple ³⁾	5 V_{SS}							
Current consumption ⁴⁾	< 50 mA							
sender	< 50 mA							
receiver	< 30 mA							
Switching outputs	PNP, Q							
	NPN, Q							
Switching mode	Dark-switching							
Output current I_A max.	100 mA							
PNP; signal voltage HIGH	$V_S - (< 2.5 V)$							
PNP; signal voltage LOW	Approx. 0 V							
NPN; signal voltage HIGH	Approx. V_S							
NPN; signal voltage LOW	< 1.5 V							
Response time ⁵⁾	< 500 μs							
Max. switching frequency ⁶⁾	1000/s							
Test input "TE" Sender OFF	TE to 0 V							
Connection types	Cable ⁷⁾ , 2 m							
	Plug							
	Cable ⁷⁾ , 100 mm, with plug							
VDE protection class	III							
Circuit protection⁸⁾	A, B, C							
Enclosure rating⁹⁾	IP 67							
Ambient temperature T_A	Operation - 40 °C...+ 60 °C							
	Storage - 40 °C...+ 75 °C							
Weight	Approx. 20 g							
Housing material	PC, polycarbonate							

- 1) Average service life 100,000 h where $T_A = + 25 °C$
- 2) Limit values
- 3) May not exceed or fall short of V_S tolerances
- 4) Without load
- 5) Signal transit time with resistive load
- 6) With light/dark ratio 1:1
- 7) Do not bend below 0 °C
- 8) A = V_S connections reverse-polarity protected
B = Output Q short-circuit protected
C = Interference pulse suppression
- 9) IP 67: with screw-in cable receptacles
IP 65: with plug-in cable receptacles

Operating range and operating reserve

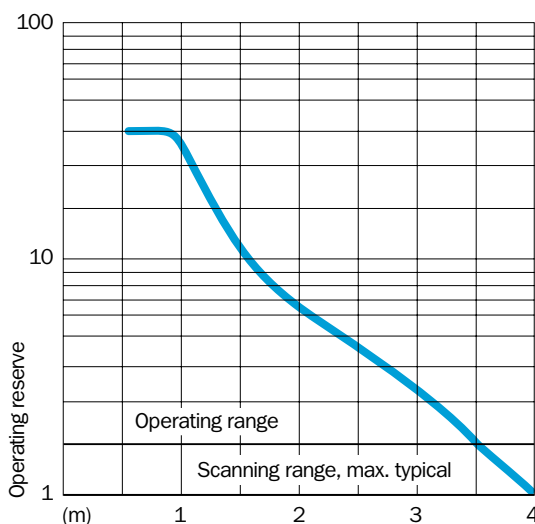
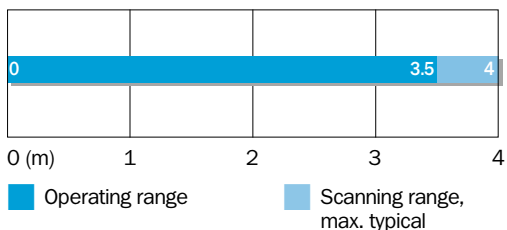

Order information

Type	Part no.
WS/WE 4-2E 132	1 015 782
WS/WE 4-2E 330	1 015 778
WS/WE 4-2E 331	1 015 774
WS/WE 4-2F 132	1 015 780
WS/WE 4-2F 330	1 015 776
WS/WE 4-2F 331	1 015 772