

Specifications

“Double Speed”

B&W Progressive Scan Camera STC-1100a and 1100b

with

Variable Integration Random Shutter Trigger

and

Vertical Reset

1. Specifications**Electrical Specification**

Image Sensor	1/3 inch Interline CCD, ICX084ALA
Effective Picture Element	659(H) x 494(V)
Optical Black	Horizontal: 33 pixel Vertical: 10 pixel
Chip Size	5.84mm(H) x 4.94mm(V)
Cell Size	7.4 μ m(H) x 7.4 μ m(V)
Scanning Area	4.88mm(H) x 3.66mm(V)
CCD V. Drive Frequency	
Double Speed	31.468 KHz \pm 1%
Normal Speed	15.734 KHz \pm 1%
CCD H. Drive Frequency	
Double Speed	24.5454 MHz \pm 1%
Normal Speed	12.2727 MHz \pm 1%
Horizontal Resolution	495 TVL
Vertical Resolution	495 TVL
Scanning System	525 lines progressive scan or 2:1 interlace
Scanning Frequency	
Double Speed Progressive	59.94Hz (V), 31.468KHz (H)
Normal Speed Progressive	29.97Hz (V), 15.734KHz (H)
Double Speed 2:1 Interlace	119.88Hz (V), 31.468KHz (H)
Normal Speed 2:1 Interlace	59.94Hz (V), 15.734KHz (H)
Sync. System	Internal or External (HD and VD)Switchable
Minimum scene illumination	
Normal Speed	1 Lux at F1.4
Double Speed	2 Lux at F1.4
S/N Ratio	More than 56dB
γ correction	0.45 or 1 (Internal switch Switchable, Factory set up=1)

Lens Mount	C-mount
Gain	Manual/Fixed/Auto Gain switchable
Shutter speed	
Normal Speed	1/60, 1/100, 1/125, 1/250, 1/500, 1/1000, 1/2000, 1/4000, 1/10000
Double Speed	1/120, 1/200, 1/250, 1/500, 1/1000, 1/2000, 1/4000, 1/8000, 1/20000
Trigger modes	One-pulse variable integration shutter trigger Two-pulse variable integration shutter trigger Vertical drive reset
Video Out	VS1.0Vp-p / 75Ω
Power Input Voltage	10 – 14Vdc
Power Current Consumption	
Normal Speed	180mA
Double Speed	210mA
Ambient Temperature	-10°C – +50°C
Dimensions	31(W) x 29(H) x 73(D)mm (excluding camera mount, connectors and lens)
Weight	85g

2. Connector Pin Assignment

a. STC-1100a



12-pin connector (Note) Mating connector: Hirose HR10A-10P-12S

Pin No.	Internal Sync. ^(note 1)	External Sync. ^(note 1)	
		HD/VD	Trigger Shutter
1	GND	GND	GND
2	+12Vdc	+12Vdc	+12Vdc
3	Video GND	Video GND	Video GND
4	Video Out	Video Out	Video Out
5	HD GND	HD GND	HD GND
6	Int. HD Out	Ext. HD In	Ext. HD In
7	Int. VD Out	Ext. VD In	
8			S-Trig GND
9			S-Trig In ^(note 2)
10	GND	GND	GND
11			M-Trig In ^(note 3)
12	VD GND	VD GND	M-Trig GND

(Notes)

1. Internal Sync. mode or External Sync. mode can be selected by the switch described in **3.b.**
When the External Sync. mode is selected and no external horizontal drive signal (HD) is applied, the camera switches to internal sync. mode automatically.
2. "S-Trig In" is the secondary trigger pulse described in **4.b.**
3. "M-Trig In (Main trigger input)" is used for the variable integration shutter trigger input and for the main trigger pulse input described in **4.b.**

b. STC-1100b



12-pin connector

(Note) Mating connector: Hirose HR10A-10P-12S

Pin No.	Internal Sync. ^(note 1)	External Sync. ^(note 1)	
		HD/VD	Trigger Shutter
1	GND	GND	GND
2	+12Vdc	+12Vdc	+12Vdc
3	Video GND	Video GND	Video GND
4	Video Out	Video Out	Video Out
5	HD GND	HD GND	HD GND
6	Int. HD Out	Ext. HD In	Ext. HD In
7	Int. VD Out	Ext. VD In	M-Trig In ^(note 3)
8			S-Trig GND
9			S-Trig In ^(note 2)
10	GND	GND	GND
11			
12	VD GND	VD GND	M-Trig GND

(Notes)

4. Internal Sync. mode or External Sync. mode can be selected by the switch described in **3.b.**
When the External Sync. mode is selected and no external horizontal drive signal (HD) is applied, the camera switches to internal sync. mode automatically.
5. "S-Trig In" is the secondary trigger pulse described in **4.b.**
6. "M-Trig In (Main trigger input)" is used for the variable integration shutter trigger input and for the main trigger pulse input described in **4.b.**

3. Switch Settings

a. Fix/Manual Gain Switch

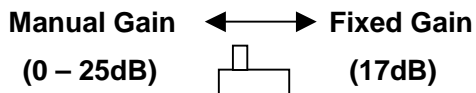
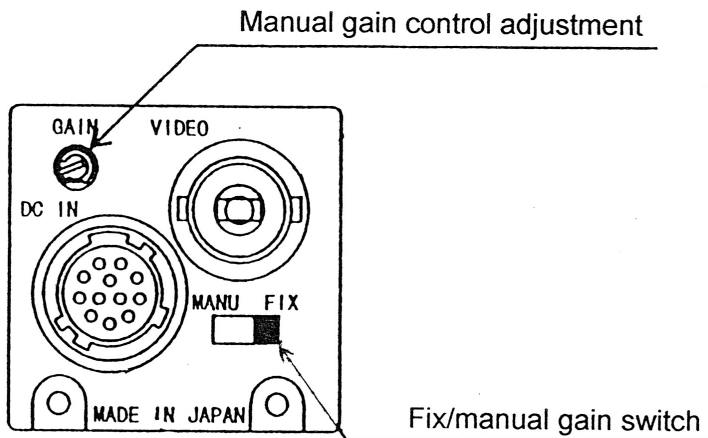

(Notes)

1. When this switch is set to Manual, Manual gain control is enabled (0 – 25dB).
2. When the DIP Switch No. 4 is set to “Off” (see 3-c-ii), this switch is disabled and automatic gain control is activated.

b. Sync. Mode Switch

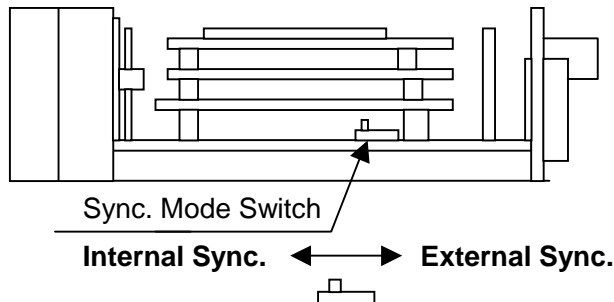

c. DIP Switch

i) DIP switch view and numbering

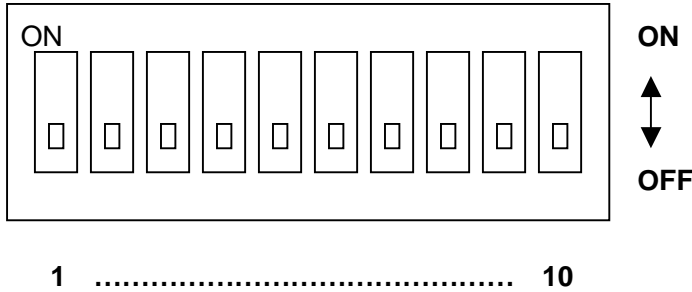

ii) DIP Switch Functions

Switch No.	Position	Function
1	ON	Progressive Mode
	OFF	2:1 Interlace
2	ON	Normal (Internal or External Sync.)
	OFF	Variable integration shutter trigger
3	ON	Normal Speed
	OFF	Double Speed
4	ON	Manual or Fixed Gain Control
	OFF	Auto Gain Control
5		Shutter Speed (See the following chart)
6		Shutter Speed (See the following chart)
7		Shutter Speed (See the following chart)
8		Shutter Speed (See the following chart)
9		Shutter Speed (See the following chart)
10	ON	Two-pulse variable integration shutter trigger
	OFF	One-pulse variable integration shutter trigger

IMPOTANT!: DIPswitch No. 5 must be turned ON and No. 6 must be turned OFF when the camera operates in the “Variable Integration Shutter Trigger Mode”.

iii) Shutter Speed Settings

Mode	Switch Number					Shutter Speed (Sec.)	
	5	6	7	8	9	Normal Speed	Double Speed
Flicker Less	ON	ON				1/100	1/200
Off	OFF	OFF				Shutter Off ^(note 1)	Shutter Off ^(note2)
High Speed Shutter	ON	OFF	OFF	OFF	OFF	1/60	1/120
	ON	OFF	ON	OFF	OFF	1/125	1/250
	ON	OFF	OFF	ON	OFF	1/250	1/500
	ON	OFF	ON	ON	OFF	1/500	1/1000
	ON	OFF	OFF	OFF	ON	1/1000	1/2000
	ON	OFF	ON	OFF	ON	1/2000	1/4000
	ON	OFF	OFF	ON	ON	1/4000	1/8000
	ON	OFF	ON	ON	ON	1/10000	1/20000

(Notes)

1. 1/30sec in Normal Speed Progressive Mode, 1/60sec in Normal Speed Interlace Mode.
2. 1/60sec in Double Speed Progressive Mode, 1/120sec in Double Speed Interlace Mode.

IMPOTANT!: DIPswitch No. 5 must be turned ON and No. 6 must be turned OFF when the camera operates in the “Variable Integration Shutter Trigger Mode”.

d. Input Signal Impedance Switch

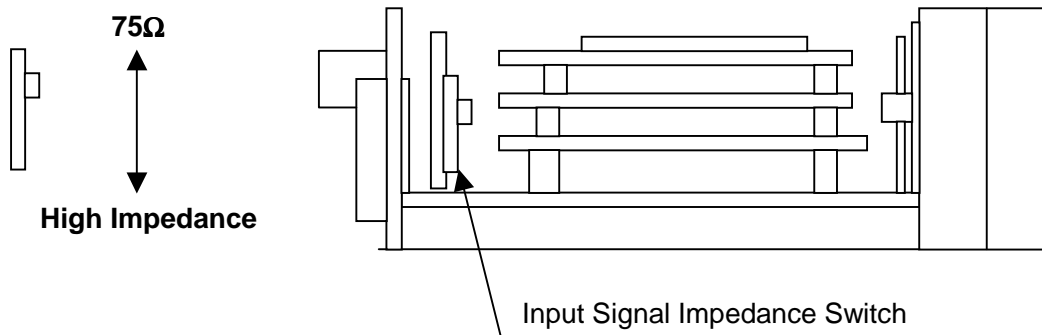

(Notes)

1. This impedance switch controls both HD and VD input impedance.
2. Set this switch to “High Impedance” when the camera is used in the variable integration shutter trigger mode.

e. Gamma Correction Switch

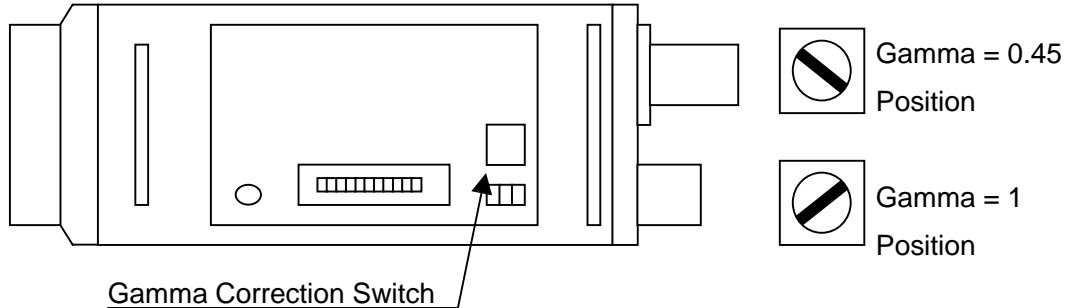

4. Input/ Output Signals

a. External Sync. Input Signals

i) HD

Input Signal Level:	2 – 5Vp-p
Termination Impedance:	75 Ω or high Impedance
Sync. Frequency:	15.734KHz \pm 1% (Normal Speed Progressive) 31.468KHz \pm 1% (Double Speed Progressive) 15.734KHz \pm 1% (Normal Speed 2:1 Interlace) 31.468KHz \pm 1% (Double Speed 2:1 Interlace)

ii) VD

Input Signal Level:	2 – 5Vp-p
Termination Impedance:	75 Ω or high Impedance
Sync. Frequency:	29.97Hz (Normal Speed Progressive) 59.94Hz (Double Speed Progressive) 59.94Hz (Normal Speed 2:1 Interlace) 119.88Hz (Double Speed 2:1 Interlace)

b. Sync. Output Signals

i) HD

Input Signal Level:	2 Vp-p at 75 Ω termination 5 Vp-p at high impedance
---------------------	---

Termination Impedance: 75 Ω or high Impedance
Sync. Frequency: 15.734KHz \pm 1% (Normal Speed Progressive)
31.468KHz \pm 1% (Double Speed Progressive)
15.734KHz \pm 1% (Normal Speed 2:1 Interlace)
31.468KHz \pm 1% (Double Speed 2:1 Interlace)

ii) VD

Input Signal Level: 2 Vp-p at 75 Ω termination
5 Vp-p at high impedance
Termination Impedance: 75 Ω or high Impedance
Sync. Frequency: 29.97Hz (Normal Speed Progressive)
59.94Hz (Double Speed Progressive)
59.94Hz (Normal Speed 2:1 Interlace)
119.88Hz (Double Speed 2:1 Interlace)

c. Variable Integration Shutter Trigger Input Signals

Low level; 0 – 0.5V
High level: 4 – 5V
Pulse duration: Please see the section 4

5. Variable Integration Shutter Trigger Operations

(Note) Double speed 2:1 interlace mode is not used in these variable integration shutter trigger operations.

IMPOTANT!: DIPswitch No. 5 must be turned ON and No. 6 must be turned OFF when the camera operates in the “Variable Integration Shutter Trigger Mode”.

a. One-pulse variable integration shutter trigger operations

1) Functions

With this “one-pulse variable integration shutter trigger mode”, one trigger pulse input signal can control camera’s integration time based on its pulse duration time. In other words, the

integration time starts at the falling edge of the trigger pulse then ends at its rising edge (see the drawing below). Since "XSUB" is activated in the camera at the falling edge of the trigger pulse and "XSG" is activated at the rising edge, the integration time is controlled very accurately.

Video signal output is sent out from the camera at the moment "t2" period ends. "t2" starts at the rising edge of the trigger pulse and ends at the 18th internal HD pulse (2:1 interlace mode) or 33rd internal HD pulse (progressive mode) after the rising edge of the trigger pulse.

Therefore, t2 is exactly 19H (2:1 interlace mode) or 34H (progressive mode) if the rising edge of the trigger pulse is synchronizing to the internal HD pulse. In the case the rising edge of the trigger pulse is not synchronizing to the internal HD pulse, this "t2" fluctuate depending on the relational timing of the two pulses as described in section 2). lii) below.

This camera provides a capability to synchronize to External HD in the variable integration shutter trigger mode. With this feature, user can easily create HD-synchronized trigger pulse for the above-mentioned operation since the internal HD synchronizes to the external HD applied to the camera.

2) Timing chart

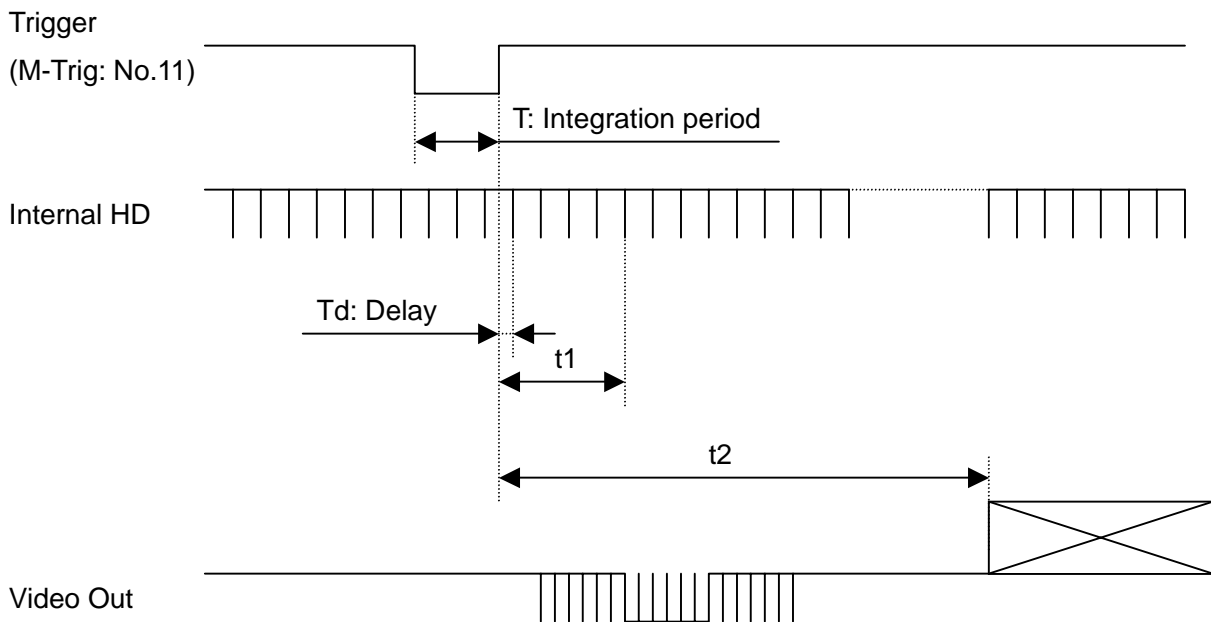

i) T: Integration period must be set within the following time length.

Normal speed interlace: $100 \mu \text{ sec} - 16.7\text{msec}$

Normal speed progressive: $100 \mu \text{ sec} - 16.7\text{msec}$

Double speed progressive: $50 \mu \text{ sec} - 8.3\text{msec}$

ii) t1: from the rising edge of the trigger pulse to the vertical sync. pulse

Normal speed interlace: $4H + Td$ (5H with HD-synchronized trigger)

Normal speed progressive: $4H + Td$ (5H with HD-synchronized trigger)

Double speed progressive: $4H + Td$ (5H with HD-synchronized trigger)

iii) t2: from the rising edge of the trigger pulse to the video out

Normal speed interlace: $18H + Td$ (19H with HD-synchronized trigger)

Normal speed progressive: $33H + Td$ (34H with HD-synchronized trigger)

Double speed progressive: $33H + Td$ (34H with HD-synchronized trigger)

i) Minimum trigger intervals are the following. Cycle speed of each trigger must be greater than these values.

Normal speed interlace: 18msec

Normal speed progressive: 36msec

Double speed progressive: 18msec

b. Two-pulse variable integration shutter trigger operations

1) Functions

The camera functions in this mode is exactly the same as above a. except that two trigger input pulses are required. The integration time starts at the falling edge of the first pulse (M-Trig) then it ends at the falling edge of the second pulse (S-Trig).

2) Timing chart

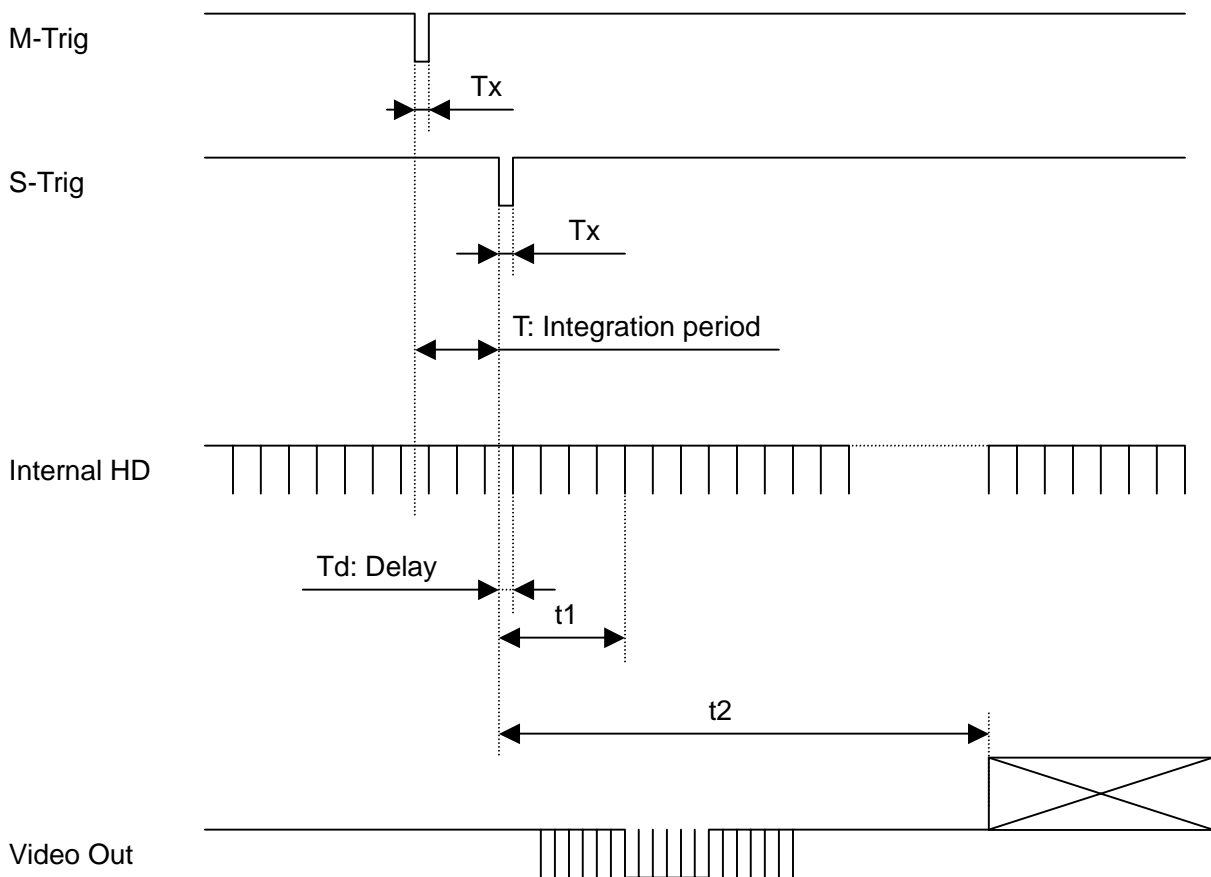

ii) T: Integration period must be set within the following time length.

Normal speed interlace: $100 \mu \text{ sec} - 16.7 \text{ msec}$

Normal speed progressive: $100 \mu \text{ sec} - 16.7 \text{ msec}$

Double speed progressive: $50 \mu \text{ sec} - 8.3 \text{ msec}$

- iii) t1: from the rising edge of the trigger pulse to the vertical sync. pulse
 - Normal speed interlace: $4H + Td$ (5H with HD-synchronized trigger)
 - Normal speed progressive: $4H + Td$ (5H with HD-synchronized trigger)
 - Double speed progressive: $4H + Td$ (5H with HD-synchronized trigger)

- iv) t2: from the rising edge of the trigger pulse to the video out
 - Normal speed interlace: $18H + Td$ (19H with HD-synchronized trigger)
 - Normal speed progressive: $33H + Td$ (34H with HD-synchronized trigger)
 - Double speed progressive: $33H + Td$ (34H with HD-synchronized trigger)

- v) Tx: trigger pulse width must be set between 1μ sec and 1msec.

- vi) Minimum trigger intervals are the following. Cycle speed of each trigger must be greater than these values.
 - Normal speed interlace: 18msec
 - Normal speed progressive: 36msec
 - Double speed progressive: 18msec

6. Vertical Reset Operations

a. Vertical reset operations

In this "Vertical Reset Mode", when the camera receives one VD pulse, only one field of video signal (2:1 interlace mode) or one frame of video signal (progressive mode) is sent out.

- 1) Turn "Sync. Mode Switch" (3.b) to "External Sync."
- 2) Turn DIP switch No. 2 (3.c.ii) to "ON (Internal or External Sync.)". The camera switches to external mode automatically when external HD is supplied.
- 3) The vertical operates as "Direct Reset Mode",
- 4) In the case of 2:1 interlace, even or odd field is determined by the timing of the falling edge of the Vertical reset pulse (see note on next page).

b. Timing chart

a) Normal and double speed 2:1 Interlace

i) Odd field reset

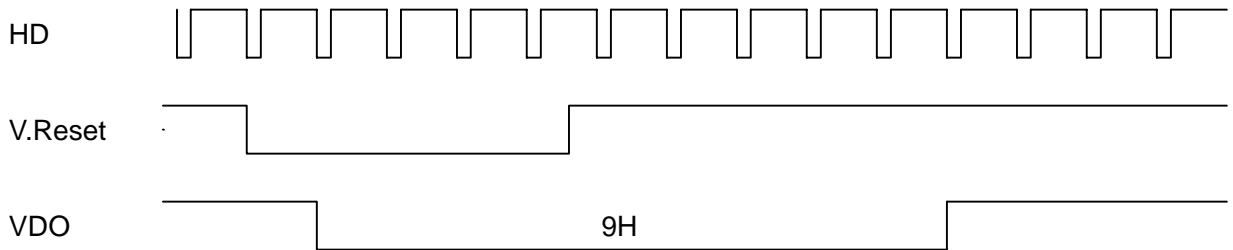

ii) Even field reset

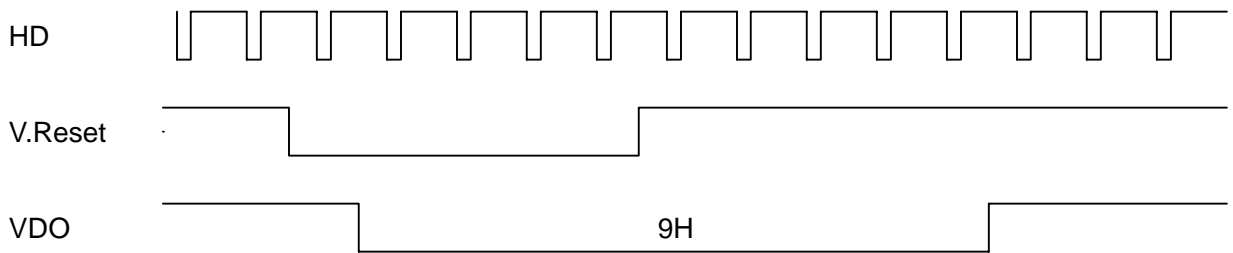

(Note) Field (odd or even) determination

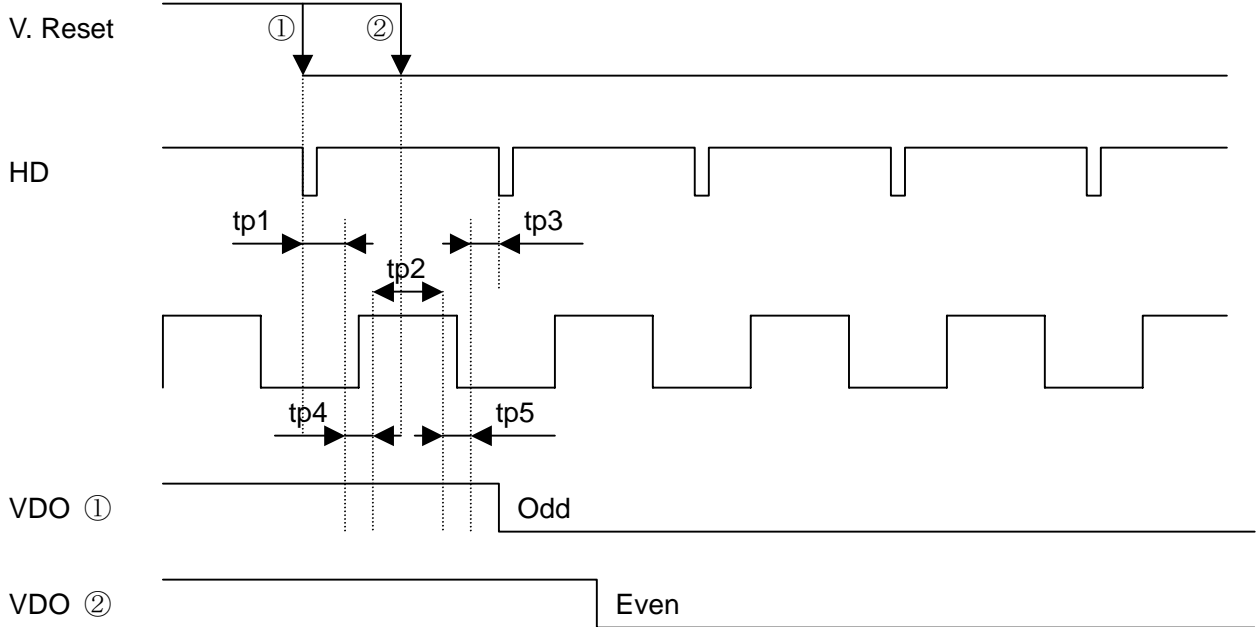

Sign	Definition	Normal Speed	Double Speed
tp1	Area to reset to Odd field	21.9 μ s	11 μ s
tp2	Area to reset to Even field	31.6 μ s	15.8 μ s
tp3	Area to reset to Odd field	-	-
tp4	Prohibited area	200 ns	100ns
tp5	Prohibited area	200 ns	100ns

(Note) tp3 is not defined as HD dwell time varies

b) Normal and double speed progressive scan

