



# ***RFL 9745***

## ***Teleprotection Channel***



### ***Key Features and Benefits***

- One product for audio, digital or fiber applications
- Up to four independent functions per audio system, seven for digital/fiber
- Sequence-of-events recording
- Address and checkback testing
- Bi-directional channel delay measurement
- Trip output failure detection
- User-defined teleprotection logic and alarms
- Remote RS-232 setup and diagnostics
- Diagnostics and setup of remote RFL 9745 through the local RFL 9745
- Three year warranty
- Optional Ethernet/Telnet adapter for remote LAN/WAN access.

The RFL 9745, is a fully programmable Teleprotection Channel suitable for Direct Transfer Trip, Permissive Transfer Trip, Blocking and Unblocking applications. Flash memory and remote RS-232 communications allows new firmware to be loaded making field programming possible without having to open the chassis. The communications interface can be converted in the field to adapt to different types of media. An unprecedented level of diagnostic information is available and easily accessible with the RFL 9745. RFL's sequence-of-events, diagnostics package provides a convenient method for evaluating communications system performance during the fault clearing process.



## Applications

The RFL 9745 communications interface can be configured for audio, digital or fiber optic media. It is well suited for all standard and non-standard pilot protections schemes such as:

- Permissive Transfer Trip
- Direct Transfer Trip
- Blocking and Unblocking

## Diagnostics and Testing

Diagnostic information is available and easily accessible with the RFL 9745. RFL's diagnostic package takes the guesswork out of power system fault analysis and evaluating communications system performance during the fault-clearing process. The RFL 9745 provides the following standard features:

- Two RS-232 ports for local and remote access
- Optional Ethernet/Telnet adapter for remote LAN/WAN access.
- Trip output circuit failure detection
- 100 Sequence-of-events records
- Internal real-time system clock
- IRIG-B Clock sync input
- Six-digit cumulative operations counters
- System outage timer
- Current status of all system parameters
- Diagnostic information about the remote end
- Checkback testing either locally or remotely initiated
- Automatic checkback by interval time between tests

- Channel propagation delay measured and reported
- Channel delay in each direction available with IRIG-B
- Commissioning can be accomplished remotely or from a single terminal

Figure 1 shows the record number, the name of the parameter that changed state to trigger the event, and the date and time the event occurred. Below this, the status of all inputs, outputs, and alarm outputs at the time of the event are listed. This information can be used to analyze the system conditions at the precise instant the event occurred.

## Programmability

Changes in field are no longer necessary for logic functions can be changed or fine-tuned remotely through the RFL 9745's RS-232 port or optional Ethernet/Telnet adapter.

### User Programmable Logic Functions

Change timer values, logic states and logic functions without ever removing a module or opening the chassis.

### User Programmable Inputs and Outputs

The RFL 9745 can be supplied with two Input/Output modules. Each module provides optically isolated inputs, solid-state or dry relay contact outputs, as well as form "C" alarm contacts. The function of all of these inputs and outputs can be individually programmed to meet the application requirements.

### Create your own alarm conditions

The RFL 9745 can be equipped with either three or six fully-programmable alarm/annunciator relays.

Record 003		Event Trigger: <i>Annunc Relay 1A Inactive</i>		Event Time: <i>01/01/98, 00:07:06.260</i>	
Input 1A		Output 1A		Rx Freq High Ch1	
Input 2A		Output 2A		Rx Freq High Ch2	A
Input 3A		Output 3A		Rx Freq High Ch3	
Input 4A		Output 4A		Rx Freq High Ch4	A
Input 1B		Output 1B		Rx Freq Low Ch1	A
Input 2B		Output 2B		Rx Freq Low Ch2	
Input 3B		Output 3B		Rx Freq Low Ch3	A
Input 4B		Output 4B		Rx Freq Low Ch4	
Annunc Relay 1A		Annunc Output 1		Tx Function Ch1	
Annunc Relay 2A		Annunc Output 2		Tx Function Ch2	A
Annunc Relay 3A	A	Annunc Output 3		Tx Function Ch3	
Annunc Relay 1B		Annunc Output 4		Tx Function Ch4	A
Annunc Relay 2B		Annunc Output 5		Address Test Fail	
Annunc Relay 3B		Annunc Output 6		Autotest Timeout	
Run Auto Test		Channel Delay		Bus Error	
FM Noise Ch1		AM Noise Ch1		Left Power Low	
FM Noise Ch2		AM Noise Ch2		Right Power Low	A
FM Noise Ch3		AM Noise Ch3		Battery Failure	A
FM Noise Ch4		AM Noise Ch4		RS232 Active	A
Comms CPU Failure		Outage Timer Active		Test in Progress	
<b>Autotest Complete</b>	<b> </b>				

Figure 1. Typical individual event record display for the Audio System



## Programming

The RFL 9745 is programmed using RFL's **Asynchronous Programming and Remote Interrogation Language (PC APRIL)**. PC APRIL provides the user with a verbose man/machine interface in an ASCII format. It is accessible using any standard terminal emulation or communication software on a personal computer.

All functions that require adjustments during normal installation and maintenance are also available by using the front-panel display and push-button switches. All programming levels available over the RS-232 (or Telnet adapter) interface are password-protected.

Every RFL 9745 is supplied pre-programmed with a default operating program. On the audio tone version, after the standard program is uploaded into the system, all the user needs to do is enter the operating frequencies and bandwidths. Figure 2 shows the parameter settings for the audio tone version, Figure 3 shows the parameter settings required for RFL 9745's configured with any of the several digital interfaces available.

A DOS version of the RFL 9745 PC APRIL software package is supplied with every order. This version allows the application engineer to save revised programming parameters

to a disk file for future downloading to the RFL 9745. The DOS program can also be utilized as a training tool to allow users to become familiar with the equipment.

A specialized software, the RFL Expert System, has been developed to allow graphical design of the system logic by using a specialized symbols library. The RFL Expert System is a WINDOWS™-based application software package which allows the user to develop his own protection schemes. This software is intended for customers who want to create, modify, or simulate applications for their RFL 9745 without having the hardware in front of them.

The RFL Expert System consists primarily of an OrCAD™ Schematic Capture Program coupled with an RFL designed WINDOWS™-based editing system and RFL's easy-to-use PC APRIL programming language. This system includes a digital simulator which allows the user to simulate logic inputs to the newly designed system logic and verify the expected results prior to uploading.

OrCAD™ Software is used to design RFL 9745 alarm logic and primitive logic diagrams. The RFL Expert System software is used to run simulations on the logic diagrams and to combine the primitive and alarm logic diagrams into one set of files for the RFL 9745. These files are then used to program the RFL 9745 using PC April Software.

#	PARAMETER	SETTING	#	PARAMETER	SETTING
999	System Label	sec/dep			
001	Channel 1	Single			
002	Tone 1 Tx Freq	1540 Hz 1690 Hz			
003	Transmit Level	0.00 dBm	004	Boost Level	0 dB
005	Tone 1 Rx Freq	1540 Hz 1690 Hz			
006	Rx Bandwidth	225 Hz	007	Rx Level	0 dBm
008	Rx Alarm	-40 dBm	009	AM Noise (SNR)	9 dB
010	FM Noise	15 %			
016	Channel 2	Single			
017	Tone 2 Tx Freq	1200 Hz 1350 Hz			
018	Transmit Level	0.00 dBm	019	Boost Level	0 dB
020	Tone 2 Rx Freq	1200 Hz 1350 Hz			
021	Rx Bandwidth	225 Hz	022	Rx Level	0 dBm
023	Rx Alarm	-40 dBm	024	AM Noise (SNR)	9 dB
025	FM Noise	15 %			
031	Channel 3	Single			
032	Tone 3 Tx Freq	2220 Hz 2370 Hz			
033	Transmit Level	0.00 dBm	034	Boost Level	0 dB
035	Tone 3 Rx Freq	2060 Hz 2370 Hz			
036	Rx Bandwidth	225 Hz	037	Rx Level	0 dBm
038	Rx Alarm	-40 dBm	039	AM Noise (SNR)	9 dB
040	FM Noise	15 %			
046	Channel 4	Single			
047	Tone 4 Tx Freq	1880 Hz 2030 Hz			
048	Transmit Level	0.00 dBm	049	Boost Level	0 dB
050	Tone 4 Rx Freq	1880 Hz 2030 Hz			
051	Rx Bandwidth	225 Hz	052	Rx Level	0 dBm
053	Rx Alarm	-40 dBm	054	AM Noise (SNR)	9 dB
055	FM Noise	15 %			
060	Opt Status Board	No	061	EE Pot J10	B
062	Chan delay alarm	8 ms	063	Year	1998
064	Date	01/01	065	Time	02:07:38
066	Hour Adjust	-1	067	Local Address	0
068	Remote Address	0	069	Reset Log	

Figure 2. Typical Audio System parameter settings display



# System Specifications

## Audio Communications

Audio tone versions of the RFL 9745 can be supplied with two or four FSK audio tone transceivers. All transceivers are bidirectional and can be programmed for any operating frequency or bandwidth between 300 and 4,000 Hz. Channel one can be set to operate as a modem channel. This channel provides a communication link to the remote terminal for remote interrogation, setting changes or system testing from the local terminal.

### AUDIO INTERFACE CONFIGURATIONS

- Single Two-Wire Terminals
- Dual Two-Wire Terminals
- Single Four-Wire Terminals
- Dual Four-Wire Terminals

### RECOMMENDED CHANNEL FREQUENCIES

Range: 300 Hz to 4000 Hz  
Resolution: 1Hz

### TRANSMIT LEVEL

Adjustable from -40 dBm +10 dBm in 0.25 dB steps

### RECEIVER SENSITIVITY

Minimum Input Level: -40 dBm  
Maximum Input Level: 0 dBm

### RECEIVER DYNAMIC RANGE (referenced to center point)

-17 dB to + 11 dB

### ADJACENT CHANNEL REJECTION

40 dB

### 60-HZ REJECTION

A received tone at -30 dBm will not be affected by a 50 Hz or 60 Hz signal as great as 40 Vrms with optional 50/60 Hz blocking filter.

### AMPLITUDE STABILITY

The Transmit level will vary by no more than  $\pm 1$  dB.

### SPURIOUS OUTPUT

All harmonics and spurious outputs are at least 40 dB lower than the carrier.

### TRANSMITTER STABILITY

The transmitter frequency is stable within 0.02 percent over the full range of temperature and input power variations.

### TRIP BOOST

Amplitude: Adjustable from zero to +12 dB in 1 dB steps.  
Duration: Adjustable from zero to 30 seconds in .5ms steps.

### INPUT AND OUTPUT IMPEDANCE

600 Ohms

## Digital Communications

The RFL 9745 is available with five types of serial digital interfaces: 56Kbps/RS-449, 64Kbps/G.703 Codirectional and Contra-directional interfaces, 64Kbps/X.21, and 2.048Mbps/G.703.

The digital interfaces conform to the standards set forth in their respective specifications (RS-449, CCITT G.703, X.21). Figure 3 represents a typical parameter settings display for the digital system.

## Fiber Optic Communications

Fiber Optic Communications Interfaces and System Gains are as follows:

Wavelength & Emitter Type	Fiber Type	Connector Type	Output Level	Receiver Sensitivity	System Gain
850 nm LED	Multimode	ST	-18 dBm	-46 dBm	25 dB
1300nm LED	Multimode	ST	-13 dBm	-39 dBm	25 dB
1300nm LED	Singlemode	ST	-17 dBm	-39 dBm	18 dB
1300nm Laser	Singlemode	ST	0 dBm	-39 dBm	36 dB
1550nm Laser	Singlemode	ST	-3 dBm	-39 dBm	30 dB
850 nm LED (short haul)	Multimode	ST	-19dBm	-32dBm	13dB

#	PARAMETER	SETTING	#	PARAMETER	SETTING
999	System Label	sec/dep			
011	Functions 1-7	Digital			
012	Major Data Error	6, 500			
013	Minor Data Error	400, 200000			
014	Alarm BER	1E-04			
060	Opt Status Board	No	062	Chan delay alarm	8 ms
063	Year	2000	064	Date	01/01
065	Time	00:00:21	066	Hour Adjust	-1
067	Local Address	0	068	Remote Address	0
069	Reset Log				

Figure 3. Typical parameter settings display for the Digital System.

Specifications subject to change without notice.



### 850 NM SHORT HAUL FIBER INTERFACE

The RFL 9745 is typically located close to the protective relaying equipment. The communications equipment, could be located in a different room or building in the substation. The RFL 9745 when configured with the Short Haul Fiber Interface, eliminates the ground potential rise and induced voltage concerns associated with routing a copper communications cable between two sites. A pair of 850 nm multimode fiber optic cables are routed between the two locations. The fibers can be up to 1 kilometer (3,280 feet) long and terminated with ST type connectors.

There are two ways to implement short haul fiber communications between the RFL 9745 and a multiplexer. The Short Haul Fiber Interface for the RFL 9745 is compliant to the ANSI C37.94 Short Haul Fiber Standard and will directly communicate to a multiplexer with a compliant interface. If the multiplexer does not support the standard, RFL can provide a remote Fiber Optic Service Unit that converts the optical signal into an electrical signal that will be accepted by the multiplexer.

The digital output of the Fiber Optic Service Unit is connected to the communications equipment by a short elec-

trical cable as shown in Figure-4. If the communications equipment supports the ANSI 37.94 Short Haul Fiber Interface standard the fiber optic cables can be interfaced directly to it as shown in Figure 5.

### SHORT HAUL SERVICE UNIT FIBER OPTIC TRANSCEIVERS

Compliant to ANSI C37.94 Short Haul Fiber Standard

Fiber Type: 50 Micron core, 850 NM Multimode  
62.5 Micron core, 850 NM Multimode

Optical Budget: 9db for 50 Micron core  
13db for 62.5 Micron core

Fiber Connector: ST

Digital Connector:  
RS-449, 64kbps, DB37 Male Connector  
V.35, 64kbps, DB37 Male Connector  
X.21, 64 Kbps, DB15 Male Connector  
G.703, 64-768 Kbps, DB15 Male Connector

### INPUT POWER

Less than 5W with a 38-150VDC power supply input.

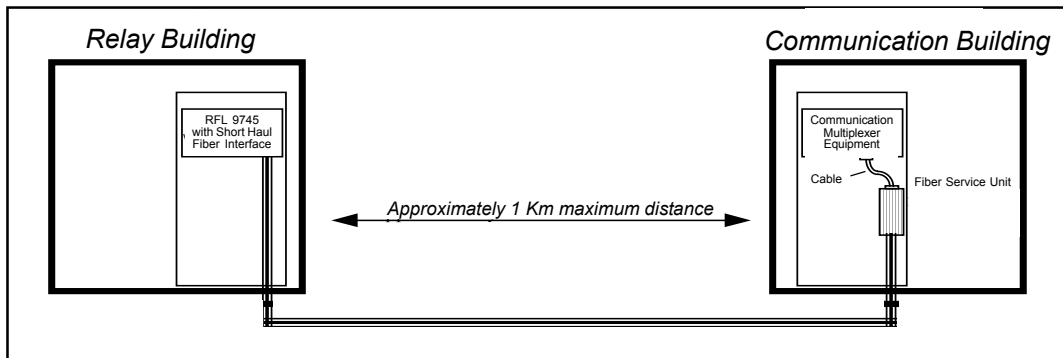

Figure 4. Typical RFL 9745 Short Haul Fiber Optic Application with Fiber Service Unit

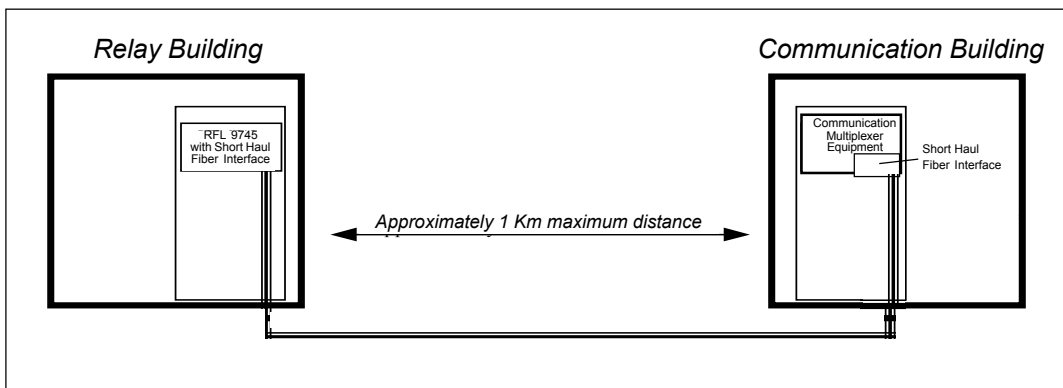

Figure 5. Typical RFL 9745 Short Haul Fiber Interface Application direct to multiplexer with C37.94 compliant I/O

*Specifications subject to change without notice.*



## Real Time Clock

### IRIG-B

The RFL 9745 accepts the IRIG-B Standard Time Code on a 1kHz modulated carrier. Nominal signal levels are 3.3 volts peak-to-peak ( $\pm 0.5v$ ) for a logic "1" and 1 volt peak-to-peak ( $\pm 0.2v$ ) for a logic "0". The IRIG-B input presents a 3.7k ohm impedance and is transformer isolated.

### RESOLUTION

1 ms

### ACCURACY

Free Running: Within 1 minute per month  
Under IRIG-B Control  $\pm 1msecs$

### RESET

Manual or by IRIG-B code

### ISOLATION

The RFL 9745's RS-232 ports (front and rear panel) are isolated from circuit common and chassis ground to a surge withstand level of 500 Vdc.

### EVENTS STORAGE

The Sequence of Events Recorder can store up to 100 events. After this limit is reached, older events are overwritten. The Events Log keeps a running tally of the number of times each function, input, output and alarm is active along with the time and date the event occurred. Up to 1,000,000 counts can be stored for each item.

### RS-232 INTERROGATION PORTS

The 9745 provides two RS-232 Ports, located on the front and rear of the chassis. The RS-232 Port located on the front of the chassis has priority. The front of the RS-232 port is configured as a DCE Interface. The rear RS-232 port is configured as a DTE Interface.

### DATA RATES

300 bps, 1200 bps, 2400 bps, 9600 bps or 19.2 Kbps. Selection is made using front panel switches.

### Communication Parameters:

Number of Data Bits: Eight  
Number of Stop Bits: One  
Parity: None  
Flow Control: XON/XOFF

## Ethernet Telnet Adapter

For applications where a telnet link is required, the RFL 9745 can be equipped with the optional Telnet Adapter module. This adapter contains one Ethernet port and two RS232 serial ports. The basic function is to pass Ethernet messages into a serial port, and to pass RS232 messages in an Ethernet port. The adapter allows the carrier set to be integrated into

a 10 Base-T Ethernet network that is becoming very common in a substation environment.

The adapter is plugged into the right options bay of the RFL 9745. One of the two serial ports is called the Craft port and the other is the Data port. These RS232 ports are three-wire RS232 ports with a DB9 connector. The Craft power is used to set up the TCP/IP and Data port parameters.

## I/O Options

The RFL 9745 can be configured with a maximum of two I/O modules. There is a Solid-State, a Relay/Solid-State, and a HS Relay version available. All versions provide four optically isolated keying inputs and three independent form "C" alarm output contacts. The Solid-State version provides four independent solid-state outputs. The Relay/Solid State version provides three independent jumper selectable form "A" or form "B" output contacts and one solid-state output and the HS Relay version provides four independent jumper selectable form "A" or form "B" output contacts.

## Solid-State I/O

### OPTICALLY ISOLATED INPUTS

Quantity: Four per module

Required Operation Range:

24 Volt Units: 14.6 to 60 Vdc, Nominal Input  
Current 8.8 mA

48 Volt Units: 31 to 60 Vdc, Nominal Input  
Current 5.8 mA

125 Volt Units: 75 to 150 Vdc, Nominal Input  
Current 4.6 mA

250 Volt Units: 155 to 280 Vdc, Nominal Input  
Current 5.25 mA

Input Current: 10 mA maximum

Minimum Acceptable Pulse Width: 100 micro-seconds

### SOLID-STATE OUTPUTS

Quantity: Four per solid-state I/O module

Output Current: Maximum 1 ampere continuous,  
2 amperes for one minute, or 10 amperes for 100 msec

Open-Circuit Voltage: 280 Vdc maximum

S/S Pick-up Time: 0 msec

### ALARM RELAYS

Quantity: Three per I/O module

Contact Configurations: SPDT (Form C)

Maximum Output Current: 1 ampere continuous

Maximum Breaking Current: 1 ampere (non-inductive)  
at 125 Vdc; derated to 0.25 amperes at 280 Vdc

Open Circuit Voltage: 280 Vdc Maximum

*Specifications subject to change without notice.*



## Relay/Solid-State I/O

### OPTICALLY ISOLATED INPUTS

Quantity: Four per module.  
Required Operation Range:  
24 Volt Units: 14.6 to 60 Vdc, Nominal Input  
Current 8.8 mA  
48 Volt Units: 31 to 60 Vdc, Nominal Input  
Current 5.8 mA  
125 Volt Units: 75 to 150 Vdc, Nominal Input  
Current 4.6 mA  
250 Volt Units: 155 to 280 Vdc, Nominal Input  
Current 5.25 mA  
Input Current: 10 mA maximum  
Minimum Acceptable Pulse Width: 100 micro-seconds

### SOLID-STATE OUTPUTS

Quantity: One per relay/solid-state I/O Module  
Output Current: Maximum 1 ampere continuous, 2 amperes for one minute, or 10 amperes for 100 ms.  
48 Volt Units: Open-Circuit Voltage: 150 Vdc maximum  
250 Volt Units: Open-Circuit Voltage: 280 Vdc maximum  
S/S Pick-up Time: 0 msec

### RELAY OUTPUT

Quantity: Three per module  
Contact Configuration: SPST Form A or Form B -Jumper Selectable  
Relay Pick-up Time: 7 msec  
Output Current Rating: 5 amperes continuous  
Surge: 30 amperes for 200 msec

### ALARM RELAYS

Quantity: Three per I/O Module  
Contact Configurations: SPDT (Form C)  
Maximum Output Current: 1 ampere continuous  
Maximum Breaking Current: 1 ampere (non-inductive) at 125 Vdc; derated to 0.25 amperes at 280 Vdc  
Open-Circuit Voltage: 280 Vdc maximum.

## HS Relay I/O

### OPTICALLY ISOLATED INPUTS

Quantity: Four per module  
Required Operation Range:  
24 Volt Units: 14.6 to 60 Vdc, Nominal Input  
Current 8.8 mA  
48 Volt Units: 31 to 60 Vdc, Nominal Input  
Current 5.8 mA

125 Volt Units: 75 to 150 Vdc, Nominal Input  
Current 4.6 mA  
250 Volt Units: 155 to 280 Vdc, Nominal Input  
Input Current: 10mA maximum  
Minimum Acceptable Pulse Width: 100 micro-seconds

### RELAY OUTPUT

Quantity: Four per module  
Contact Configuration: SPST Form A or Form B -Jumper Selectable  
Relay Pick-up Time: 5 msec  
Output Current Rating: 5 amperes continuous  
Surge: 30 amperes for 200 msec

### ALARM RELAYS

Quantity: Three per I/O Module  
Contact Configurations: SPDT (Form C)  
Maximum Output Current: 1 ampere continuous  
Maximum Breaking Current: 1 ampere (non-inductive) at 125 Vdc; derated to 0.25 amperes at 280 Vdc  
Open-Circuit Voltage: 280 Vdc maximum

### ANNUNCIATOR CHASSIS

The RFL 9745 can be supplied with an optional one rack unit Annunciator Chassis. This additional chassis is mounted below the standard Three Rack Unit Chassis and provides six programmable solid-state outputs. Each output can be individually programmed to provide specific output annunciation, such as Trip Sent, Trip Received, RS-232 Port Active, etc.

### OUTPUT RATINGS

Maximum Output Current: 1 A continuous  
Breaking Current: 100 mA (non-inductive)

## Auxiliary Trip Relays

The RFL 9745 can be configured with up to two auxiliary high speed trip relays which are mounted in either the primary or redundant power supply I/O module. The relays are typically controlled by one of the solid-state function outputs and provide two normally open and one normally closed contact each.

### Relay Ratings:

Pick-up Time: 4 msec  
Contact Rating: 5 amperes continuous, 30 amperes for 200 msec

*Specifications subject to change without notice.*



## General Specifications

### DISPLAYED LEVEL ACCURACY

The levels displayed on the front panel and through remote access using PC APRIL will be within 1 dB of the actual values.

### OPERATE TIME

Audio-Tone Units (average trip times—Dual-Tone System):

- ± 30 Hz Shift: 26.47 ms
- ± 42.5 Hz Shift: 20.57 ms
- ± 60 Hz Shift: 14.78 ms
- ± 75 Hz Shift: 12.65 ms
- ± 120 Hz Shift: 11.05 ms
- ± 150 Hz Shift: 10.12 ms
- ± 240 Hz Shift: 9.22 ms

Digital and Fiber systems: 3 ms maximum in the most secure mode. "Operate Time" is defined as the time from the receipt of a command input to the response of a solid-state output, less any channel propagation time.

### PRE-TRIP TIMER

Adjustable in 0.5 ms steps

### TRIP HOLD TIMER

Adjustable in 0.5 ms steps

### COMMAND EXTEND TIMER

Adjustable in 0.5 ms steps

### NON-VOLATILE STORAGE

All parameters relating to system operation are stored in electric erasable non-volatile RAM. All parameters related to event logging are stored in battery-backed RAM.

### RFI SUSCEPTIBILITY

ANSI PC37.90.2 (35 Volts/Meter)  
IEC 255-22-3 (RFI Class III)

### INTERFACE DIELECTRIC STRENGTH

All contact inputs, solid-state outputs, power supply inputs and relay outputs meet the following specifications:

- ANSI C37.90-1989 (Dielectric)
- ANSI C37.90.1-1989 (SWC and Fast Transient)
- IEC 255-5 (1500 Vrms Breakdown Voltage and Impulse Withstand)

IEC 255-22-1 (SWC Class III)  
IEC 255-22-2 (ESD Class III)  
IEC 255-22-4 (Fast-Transient Class III)  
IEC 834-1

### INPUT POWER REQUIREMENTS (PER IEC 834-1)

24 Vdc Supply: 19 to 29 Vdc (1500 mA Typical)  
48/125 Vdc Supply: 38 to 150 Vdc (750/325 mA Typical)  
250 Vdc Supply: 170 to 300 Vdc (150 mA Typical)

### POWER SUPPLY

A single or redundant power supply can be provided depending on the reliability of the application. For example a DTT application for a higher voltage level line may demand the dependability of a redundant power supply.

### TEMPERATURE

Operating: -30° C to +65° C (-22° F to +149° F)  
Storage: -40° C to +75° C (-40° F to +165° F)

### RELATIVE HUMIDITY

Up to 95 percent at +40° C (+104° F), non-condensing

### CHASSIS DIMENSION

The RFL 9745 chassis mounts in a standard 19-inch rack or cabinet and is three rack-units high (5.25 inches or 13.3 cm). Front and rear views, cut-out dimensions, and terminal block locations are illustrated in fold Figures 6 and 7. A system block diagram for the RFL 9745, including available options, is shown in fold-out Figure 8. The RFL 9745 can be supplied with plug-in connectors for the Solid-State I/O, Relay/Solid-State I/O and the HS Relay I/O Module. These connectors can accept #14 AWG wire and proved a convenient method to add or replace I/O modules in the field.

### WARRANTY STATEMENT

RFL's standard warranty for the RFL 9745 is *thirty-six* months from date of delivery for replacement or repair of any part which fails during normal operation or service.

### ORDERING INFORMATION

RFL 9745 ordering information can be found on page eleven.

*Specifications subject to change without notice.*



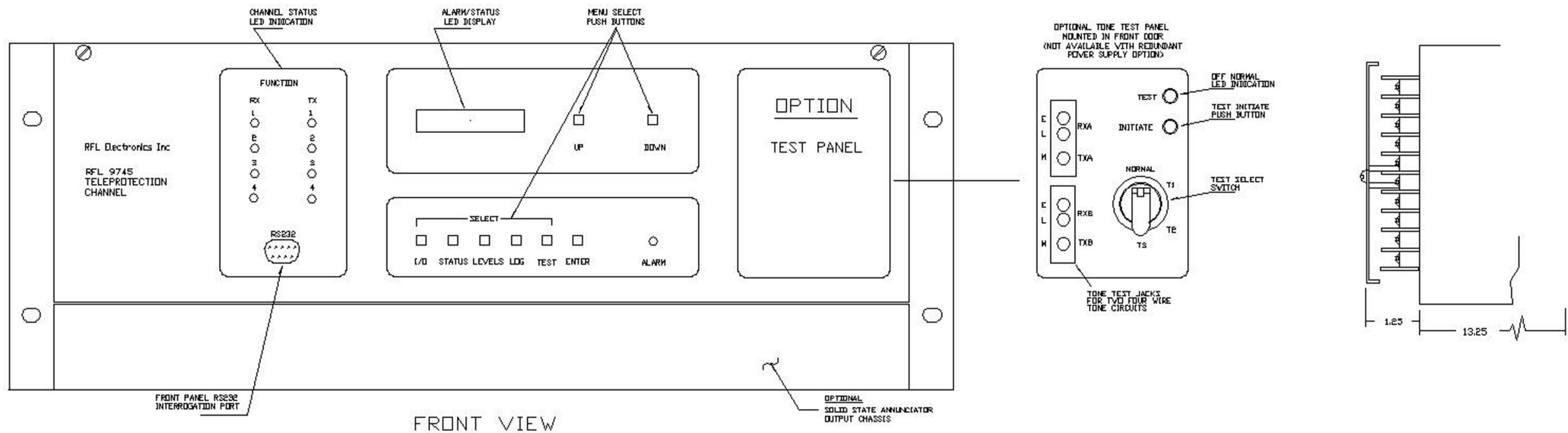

FRONT VIEW

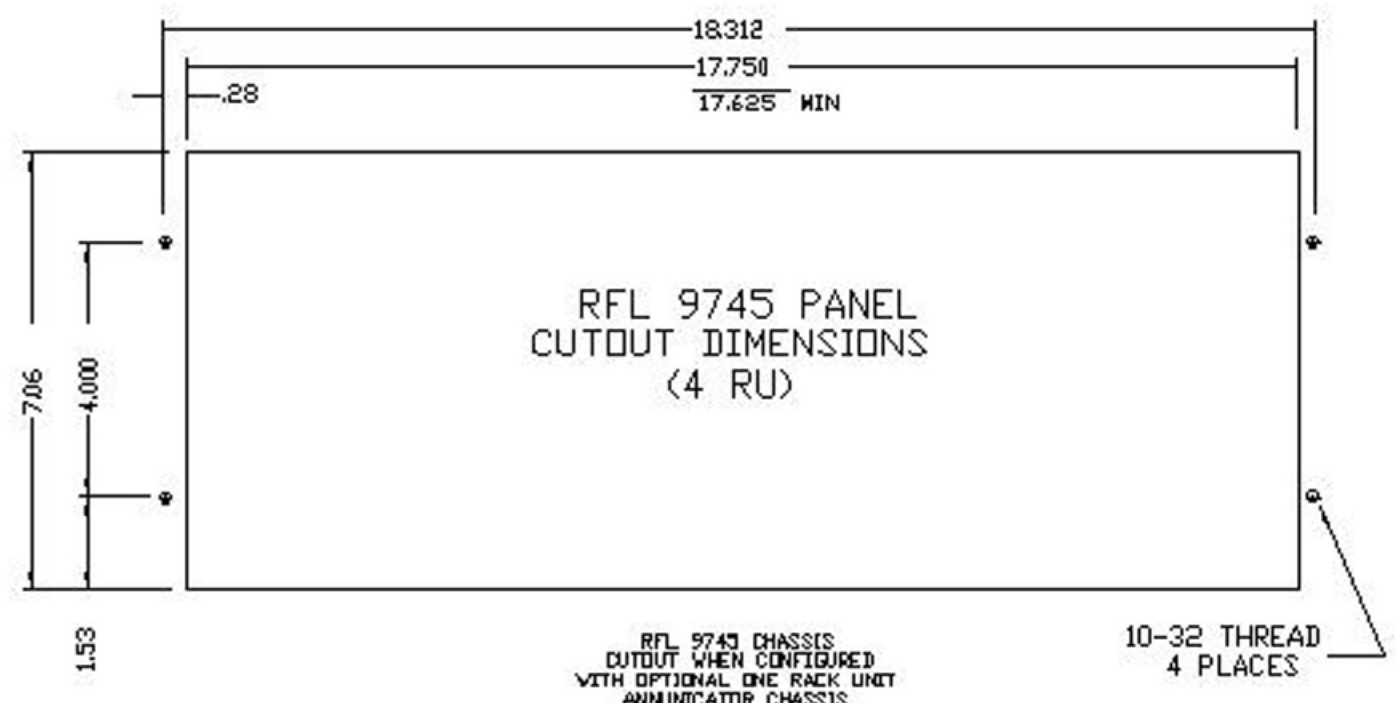
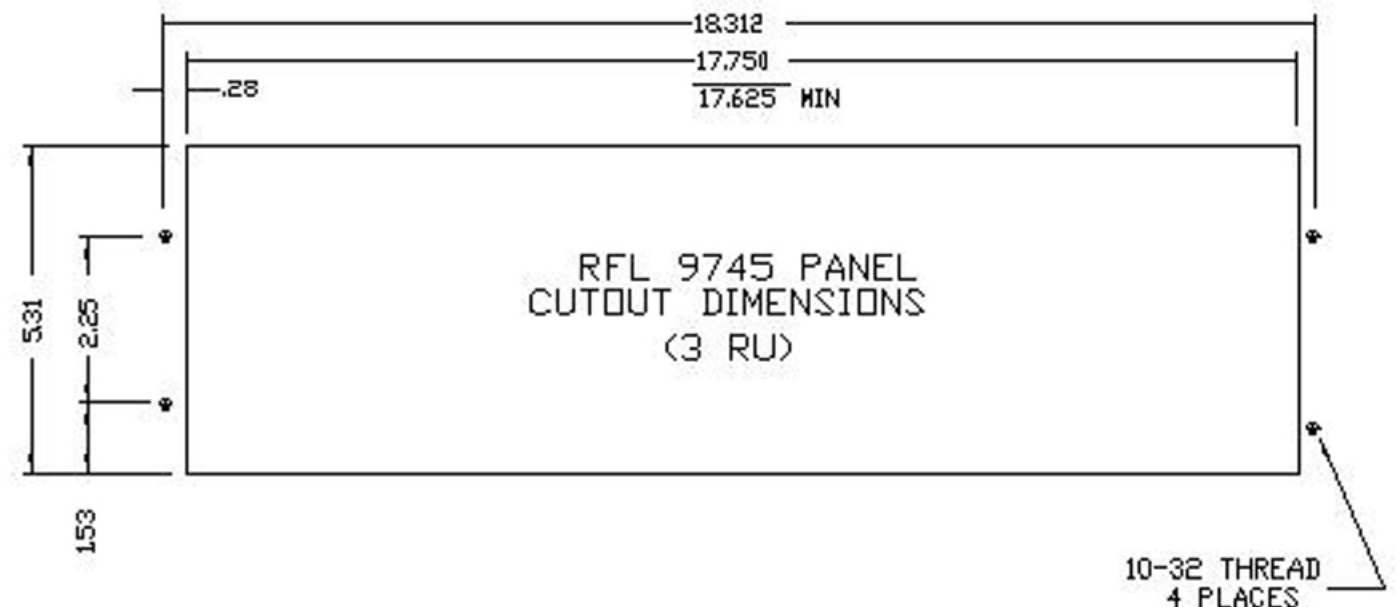

REMOTE FIBER OPTIC SERVICE UNIT

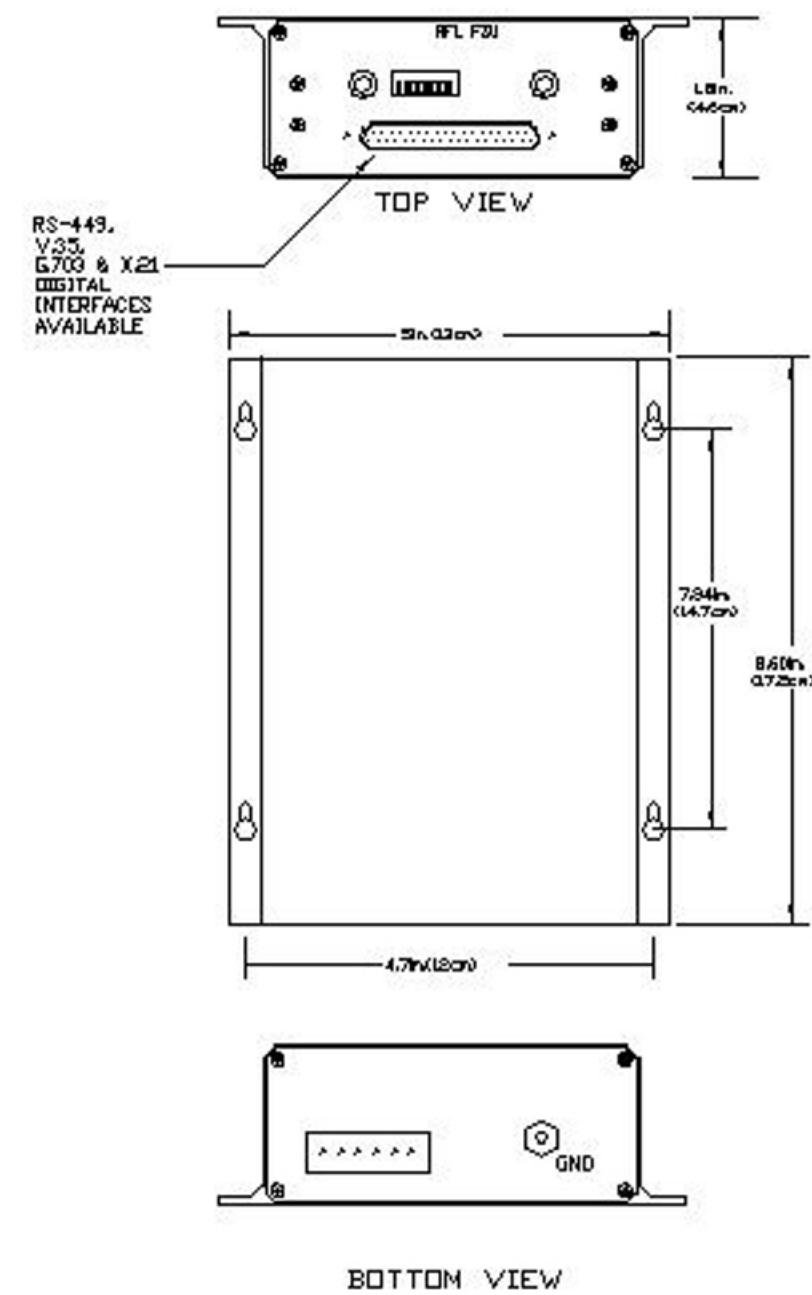



CPU BOARD  
68000 MAIN CPU  
PROGRAM STORAGE (FLASH)  
TMS320C25 PRIMITIVE PROCESSOR  
PROGRAM STORAGE (RAM)

COMMUNICATIONS I/F MODULE AND IRIG-B RECEIVER

**AUDIO COMMUNICATIONS**  
AVAILABLE WITH TWO, THREE OR FOUR PROGRAMMABLE FSK AUDIO TONE TRANSCIEVERS. OUTPUTS CAN BE CONFIGURED FOR:  
(A) ONE 2 WIRE CIRCUIT  
(B) ONE 4 WIRE CIRCUIT  
(C) TWO 4 WIRE CIRCUITS (WITH TWO TONES PER 4 WIRE CIRCUIT)

- TB2-1 RXB
- TB2-2
- TB2-3 TXB
- TB2-4
- TB2-5 RXA
- TB2-6
- TB2-7 TXA
- TB2-8

**DIGITAL COMMUNICATIONS**  
56 OR 64 Kbps DIGITAL 15 BIT MESSAGE  
2.048 Nbps DIGITAL 15 BIT MESSAGE

DIGITAL I/O MODULE

RS449  
G.703 CO-DIRECTIONAL 64Kbps  
G.703 CONTRA DIRECTIONAL 64Kbps  
G.703 E1 2.048 Mbps - 75/120 OHM X.21

650NM MULTIMODE LED  
1300NM MULTIMODE LED  
1300NM SINGLEMODE LED  
1300NM SINGLEMODE LASER  
1550NM SINGLEMODE LASER  
650NM MULTIMODE LED SHORT HAUL INTERFACE

\* REQUIRES RFL REMOTE FIBER OPTIC SERVICE UNIT P/N 105075 TO BE INSTALLED AT COMMUNICATING EQUIPMENT LOCATION

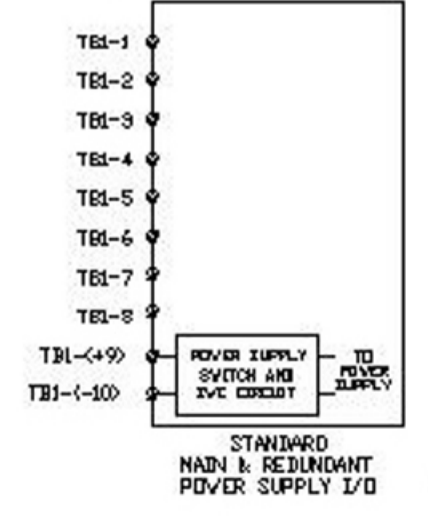
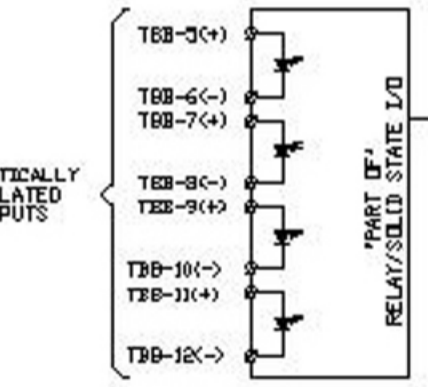
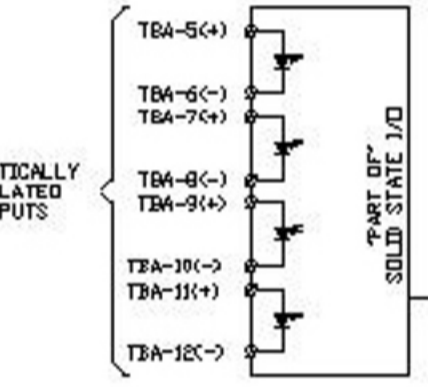
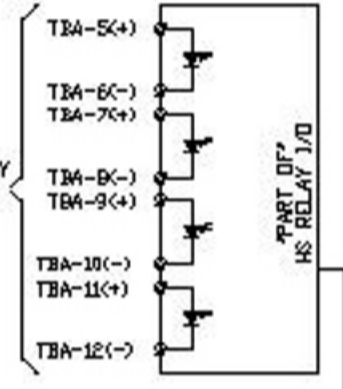
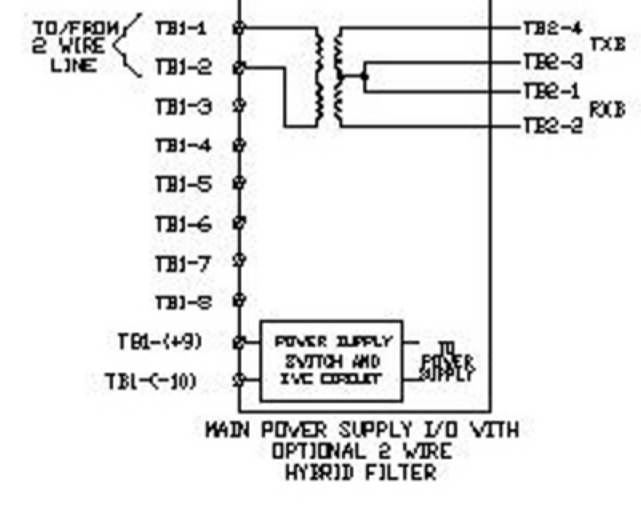
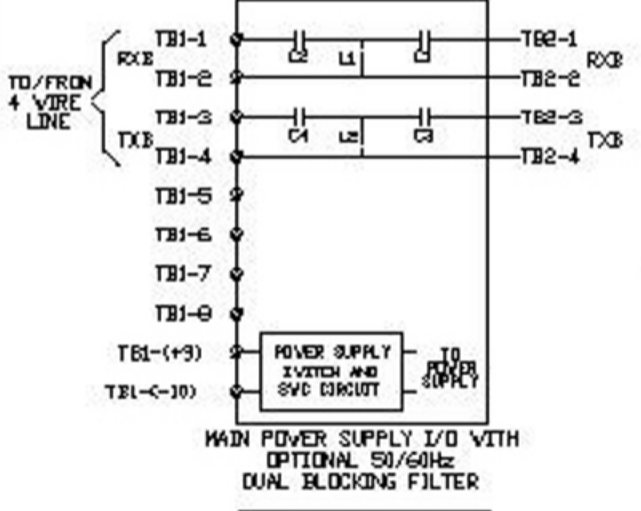
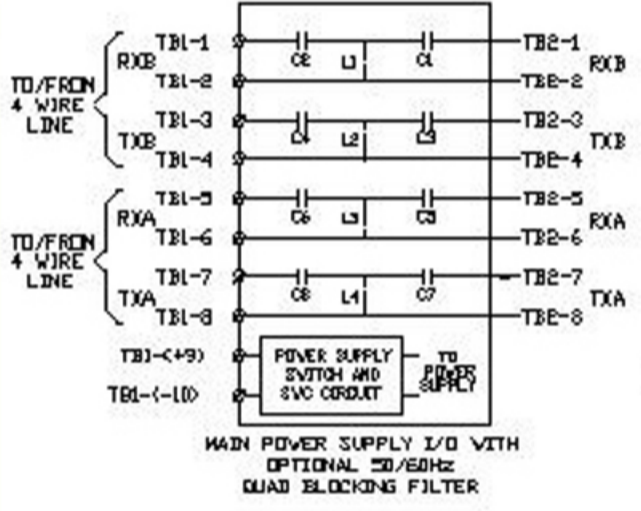
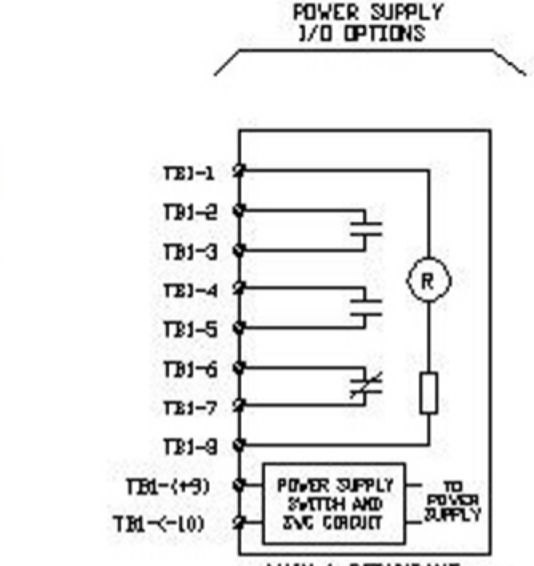

FRONT PANEL LED DISPLAY TEST AND STATUS SELECT SWITCHES RS 232 PORT

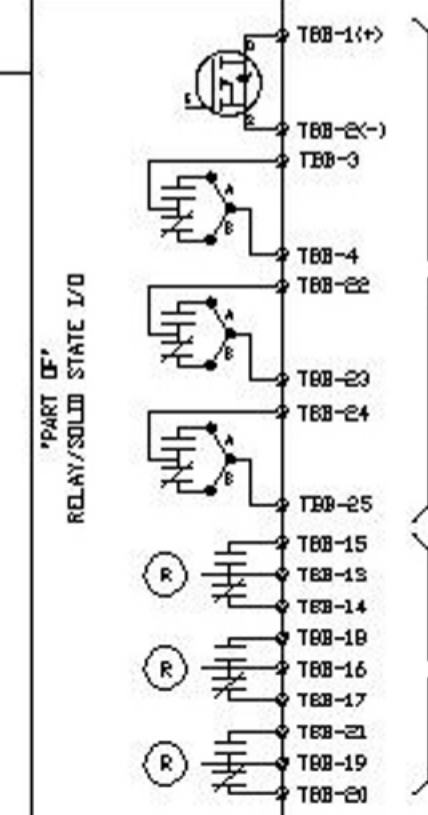
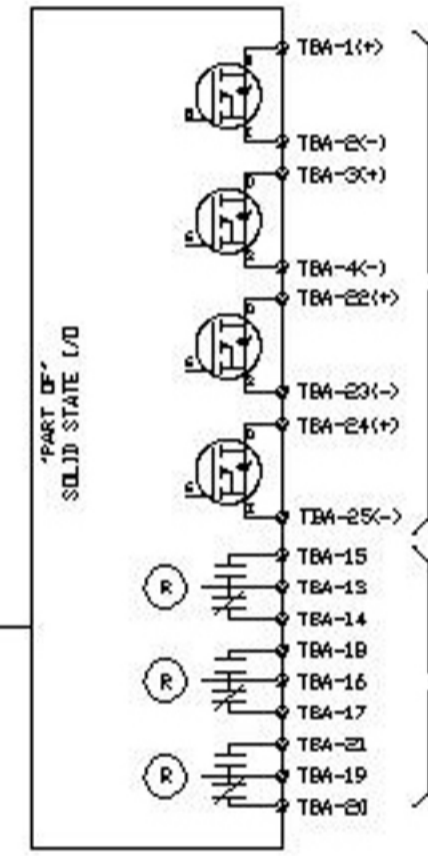
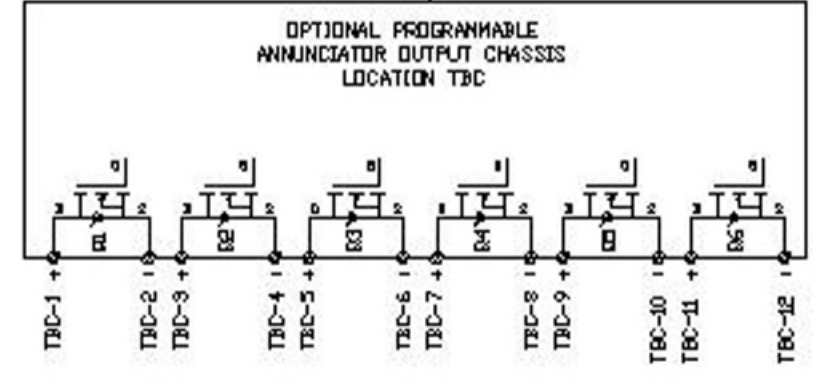
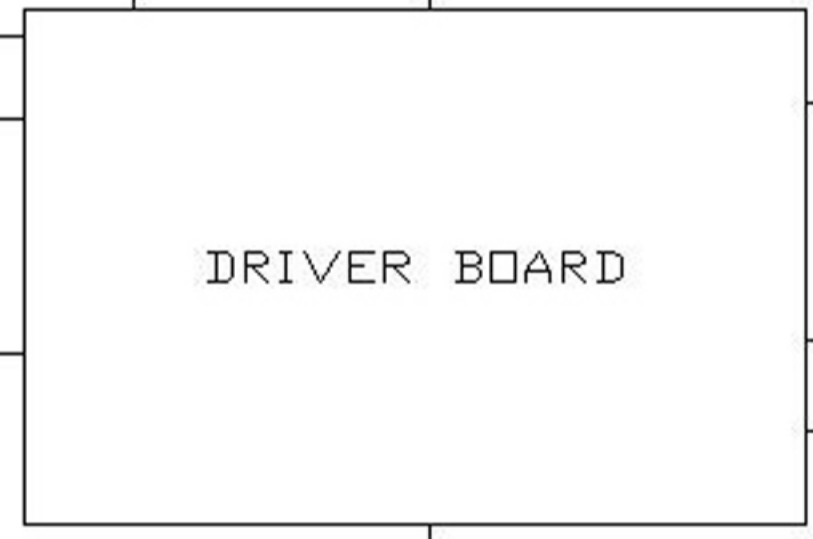

OPTIONAL TONE TEST PANEL

MODEL 9745 TEST SWITCH P/N 102245	POSITION ENGRAVING	CONTACTS	NORMAL	TL	TR	TS
1-2			X			
3-4			X	X	X	X
5-6			X	X	X	X
7-8			X	X	X	X
9-10			X	X	X	X
11-12			X	X	X	X

2 INDEPENDENT SETS OF FORM 'C' ALARM OUTPUT CONTACTS

1 SOLID STATE AND 3 JUMPER SELECTABLE FORM 'A' OR FORM 'B' FUNCTION OUTPUT CONTACTS

3 INDEPENDENT SETS OF FORM 'C' ALARM OUTPUT CONTACTS

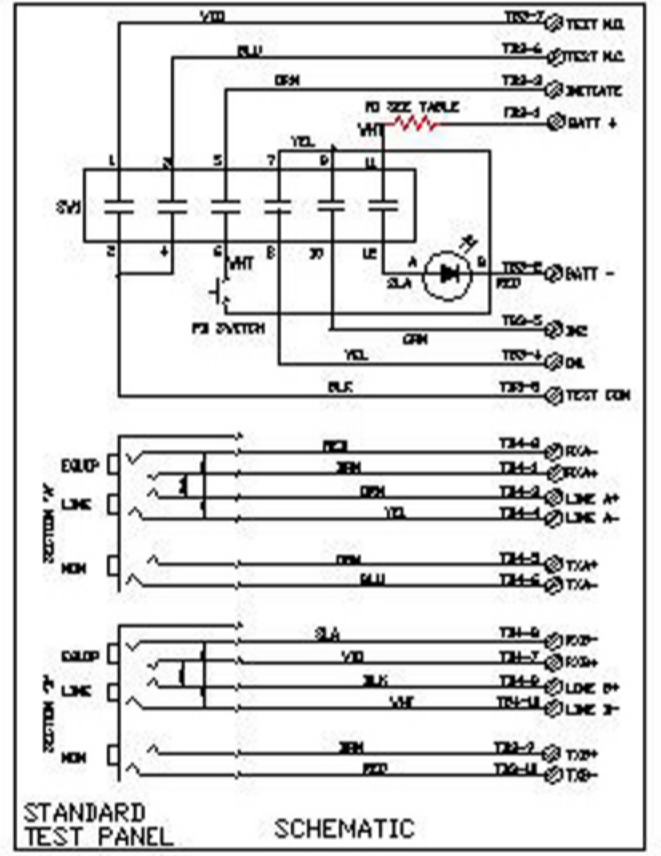

NOTE: POWER SUPPLY I/O OPTIONS ARE IDENTIFIED AS TB3 WHEN INSTALLED IN THE LEFT SIDE (REARVIEW) OF THE CHASSIS.

# RFL 9745 Teleprotection Channel

## Ordering Information

RFL Part Number (fill in blanks):	Base System	<b>TSH</b>					
<b>COMMUNICATIONS</b>							
2 Tone Audio Wide Range K=terminal block, M=compression block		K-M					
4 Tone Audio Wide Range N=terminal block, W=compression block		N-W					
56/64 Kbps Digital RS-449		A					
64 Kbps G.703 Co-Directional		B					
64 Kbps G.703 Contra-Directional		C					
2.048 Mbps, G.703 75/120 Ohm		Q					
850 nm Short Haul ANSI C37.94 Compliant (Ref. Note 1)		P					
850 nm Multimode		E					
1300 nm Multimode		F					
1300 nm Singlemode		G					
1300 nm Singlemode LASER		H					
1550 nm Singlemode LASER		J					
64Kbps Digital X.21		X					
<b>PRIMARY POWER SUPPLY</b>							
19-36 Vdc			4				
38-150 Vdc			6				
170-300 Vdc			7				
<b>REDUNDANT POWER SUPPLY, TEST PANEL or Telnet I/O</b>							
None			0				
19-36 Vdc (Redundant PS I/O included)			4				
38-150 Vdc (Redundant PS I/O included)			6				
170-300 Vdc (Redundant PS I/O included)			7				
Front Door with Test Panel			5				
Telnet I/O			8				
<b>I/O BOARD (TOP) Choose From Below</b>							
<b>I/O BOARD (BOTTOM) Choose From Below</b>							
None			0				
24-Vdc Solid State A = terminal block, C = compression block			A or C				
48/125-Vdc Solid State 1 = terminal block, 3 = compression block			1 or 3				
250-Vdc Solid State 2 = terminal block, 4 = compression block			2 or 4				
24-Vdc Relay/SS B = terminal block, D = compression block			B or D				
48/125-Vdc Relay/SS 5 = terminal block, 7 = compression block			5 or 7				
250-Vdc Relay/SS 6 = terminal block, 8 = compression block			6 or 8				
24-Vdc HS Relay E = terminal block, F = compression block			E or F				
48/125-Vdc HS Relay G = terminal block, H = compression block			G or H				
250-Vdc HS Relay J = terminal block, K = compression block			J or K				
<b>OPTIONAL 1 RU ANNUNCIATOR CHASSIS</b>							
None			0				
6 solid-state 48/125 Vdc 2=terminal block, 4=compression block			2 or 4				
6 solid-state 250 Vdc 3=terminal block, 5=compression block			3 or 5				
<b>POWER SUPPLY I/O OPTIONS</b>							
None			0				
One 48-Vdc Aux relay (4ms) 3 Contacts			1				
One 125-Vdc Aux relay (4ms) 3 Contacts			2				
Two 48-Vdc Aux relay (4ms) 3 Contacts each (Ref. Note 2)			3				
Two 125-Vdc Aux relay (4ms) 3 Contacts each (Ref. Note 2)			4				
Dual Four Wire 50/60 Hz Blocking Filter (Quad Filter)			5				
Four Wire 50/60 Hz Blocking Filter (Dual Filter)			6				
Two Wire Hybrid			7				

- NOTES: 1. If a fiber service unit is required it must be ordered as a stand alone item. P/N-107460-1, RS449 (38-150 Vdc); P/N-107460-2, V.35 (38-150 Vdc); P/N-107460-3, G.703 (38-150 Vdc); P/N-107460-4, X.21 (38-150 Vdc); P/N-107460-5, E1 (38-150 Vdc).
2. If a test panel or Telnet is selected, the two Aux Relay option is not available.



**RFL Electronics Inc.**  
353 Powerville Road  
Boonton Twp., NJ 07005-9151  
Tel: 973.334.3100  
Fax: 973.334.3863  
[www.rflect.com](http://www.rflect.com)  
email: [sales@rflect.com](mailto:sales@rflect.com)

