

QTERM-G70

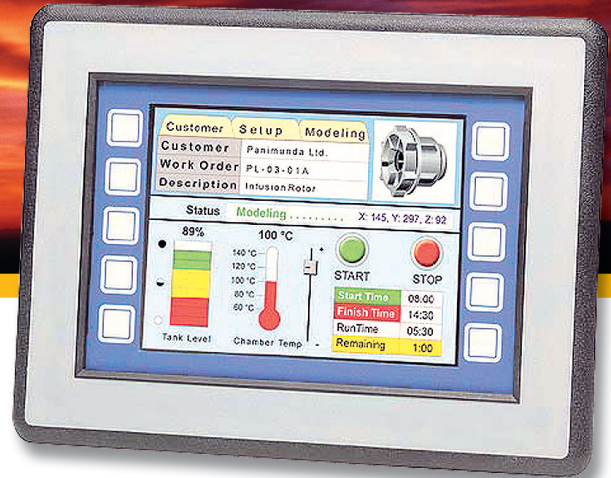

Ethernet-Enabled Graphic Terminal
with Object-Based Programming

QSI
CORPORATION

2212 South West Temple #50
Salt Lake City, Utah
84115-2648
USA

Phone 801-466-8770
Fax 801-466-8792
Email info@qsicorp.com
www.qsicorp.com

Rev. 3.0

© 2004 QSI Corporation. QSI reserves the right to modify this document and/or the product(s) it describes without notice. In no event shall QSI be liable for incidental or consequential damages, or for the infringement of any patent rights or third party rights, due to the use of its products.



FEATURES

- 320x240 pixel, 143 mm (5.6") diagonal, lighted LCD display: transfective grayscale, STN color, TFT color, or enhanced TFT color
- Available in panel-mount enclosure or as module for tighter integration.
- Touch screen with soft keys on and around viewable area.
- 10Base-T Ethernet option; supports TCP/IP, UDP/IP and other protocols
- Power-over-Ethernet (802.3af) option.
- Two serial ports (2nd optional). EIA-232, -422, -485 on either.
- Optional PS/2 keyboard port.
- Full NEMA-4 sealing for hose-down, icing, salt spray.
- -10 to 60 °C operating temperature; consumes 520 mA @ 12 VDC.
- Powerful **Clarity** object-based programming for easy application development.
- Windows® programming, simulation and debugging environment.
- Real-time clock, programmable speaker, optional audio (.wav) decoder.
- Manufacturer ID code protects your development investment.
- CE Certified, UL 94V-0 housing.
- Make the G70 *your* product with a custom company logo and softkey legend.



HARDWARE

DISPLAY: The QTERM-G70 features a QVGA (320x240 pixel) STN color (256 colors) or grayscale (16 shades of gray) graphic LCD display. The terminal can optionally be configured with an active matrix, TFT color display for increased visibility. An enhanced TFT display is available for viewing in bright sunlight conditions.

The LCD display has excellent readability under most lighting conditions and can operate in either portrait or landscape mode. The display is lighted with a cold-cathode fluorescent backlight (CCFL). The CCFL backlight is replaceable and provides white lighting for high contrast and easy readability. Brightness of the backlight and contrast are controlled by software.

For applications that require larger and higher resolution screens, we offer the QTERM-G75.

TOUCH SCREEN / KEYPAD / KEYBOARD: User input occurs through a durable resistive touch screen via any number of keys located on or around the display and/or through an external keypad (up to 8x8 matrix with up to 6 keypad LEDs) or PS/2 keyboard. Touch screen keys are not limited to a certain size or “active” area.

The standard legend shown in Figure 1 shows five soft keys down either side of the display. These keys can have unique functions on every screen, have a global function on all screens or be customized with your choice of text and graphics. A custom legend underlay can be ordered to personalize the unit for your application.

HOUSING: The QTERM-G70 offers a rugged, glass-filled polyester, (UL 94V-0) panel-mount housing that meets all NEMA-4 specifications for hose-down, icing and salt spray when mounted in a NEMA-4 panel. See Figure 3 for dimensions.

The terminal is designed to be mounted in a hole cut in your panel (Figure 2). No screw holes are required; a gasket and mounting hardware are included with the unit.

Using the drywall-mount case, the QTERM-G70 can be securely mounted even when there is no access to the back of the panel. Often used in finished construction, this unique mounting system uses cams to hold the terminal in drywall and similar materials.

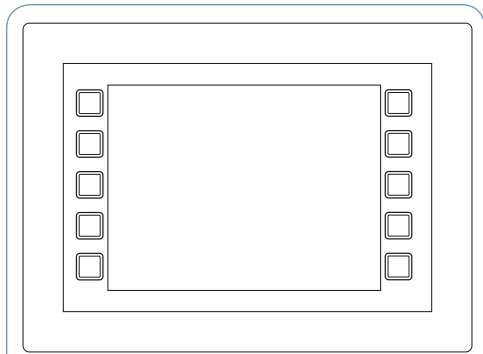
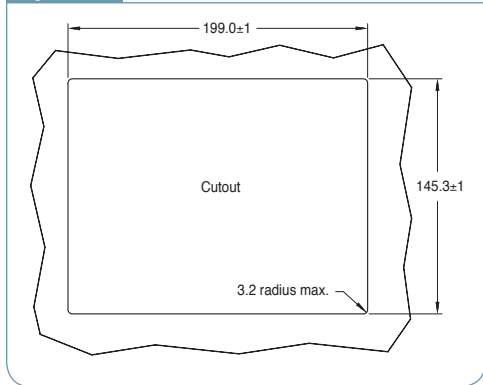

Figure 1 ▲ QTERM-G70 with standard legend

Figure 2 ▼ QTERM-G70 cutout dimensions



The drywall-mount option requires a different case and must be ordered at time of purchase.

The components of the QTERM-G70 are available as a module (display, CPU board, touch screen and mounting bracket) for mounting in your housing if these mounting options will not fit your needs.

CONNECTORS: The QTERM-G70 comes standard with one DB9f serial connection, two if the terminal is configured with the second serial option. The terminal can optionally support a standard PS/2 keyboard and an 8-pin modular Ethernet connector (RJ45). The PS/2 keyboard is not an available option when selecting the Power-over-Ethernet option.

SPEAKER: A speaker with software-controlled pitch and duration is included on the rear of the unit. Pitch is set by specifying musical tones to simplify creation of distinctive audio sequences.

The QTERM-G70 can optionally be configured with an audio chipset (codec) to play voice, music or other .wav files through the speaker. These sounds can be played in response to events such as a key press, a critical setpoint reached, data received or other events.

FLASH MEMORY: The QTERM-G70 includes 4 Mbytes of flash memory and 16 Mbytes of RAM. The flash memory contains the firmware, user application, objects and file space.

Firmware and application upgrades can be downloaded through the serial or Ethernet interfaces and into memory without opening the terminal housing.

POWER SUPPLY: The QTERM-G70 includes a switching power supply with a wide input voltage range (8-26 VDC). Typically, power is supplied through the DB9f connector, however, if you have chosen the Power-over-Ethernet (PoE) option, power is supplied through the CAT5 Ethernet cable and your PoE-compliant hub.

Power-over-Ethernet (PoE) (IEEE 802.3af), also called “Active Ethernet,” eliminates the need to supply 115 VAC to your wired Ethernet terminal. By running a single CAT5 cable providing power lines in addition to data lines, you have greater flexibility in where you locate your terminal and you significantly reduce installation costs.

BATTERY-BACKED REAL-TIME CLOCK: The real-time clock can be used to display the current time on the display, time and date stamp messages or for timed polling and program execution.

SERIAL PORT: The standard QTERM-G70 ships with one EIA-232 serial interface with hardware handshaking. The primary and / or optional secondary serial ports can be configured for EIA-232, EIA-422 or EIA-485.

ETHERNET / POWER-OVER-ETHERNET: An Ethernet 10Base-T port with an 8-pin modular Ethernet connector (RJ45) is available as an option. TCP/IP, UDP/IP, Modbus™ and other communications are supported.



The QTERM-G70 provides valuable information to the user of this metal forming machine.

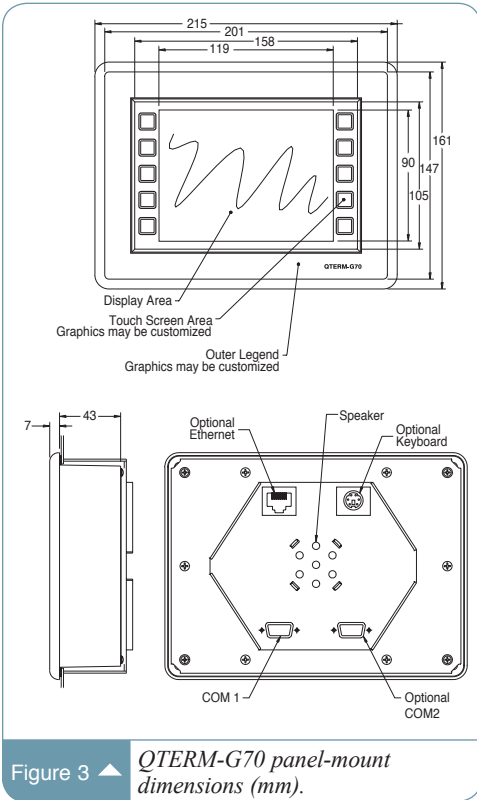

Figure 3 ▲ QTERM-G70 panel-mount dimensions (mm).

SOFTWARE AND SETUP

OBJECT-BASED PROGRAMMING LANGUAGE: Software for the QTERM-G70 is based on QSI's scripted graphic terminal programming language called **Qlarity™** (pronounced "Clarity"). **Qlarity** uses objects to display information on the screen, accept user input and communicate with other devices.

PROGRAMMING TOOLS: **Qlarity Foundry™** is a PC-based software tool that aids in screen design, application development, compilation and loading programs into the QTERM-G70. **Qlarity Foundry** is powerful enough for the elementary user, yet flexible enough for the technical user. Intelligent applications can be created by modifying object properties and without writing a single line of code.

For more information about **Qlarity™** and **Qlarity Foundry** refer to the appropriate section of this catalog or visit us on the web at www.qlarity.com.

MANUFACTURER ID: A unique MID code can be factory programmed into your QTERM-G70 (for a nominal one-time setup fee). Your **Qlarity** application can query this MID code to determine if the terminal was purchased by you. If the MID code does not match, your application can halt, preventing your software from being used on QSI terminals purchased by others, and protecting your development investment.

INTERFACES

EIA-232: With proper cables and grounding, the QTERM-G70 can communicate up to 15 meters at its top speed of 115,200.

EIA-422: Using the EIA-422 interface, the QTERM-G70 can operate at distances up to 1000 meters.

EIA-485: Multiple terminals can be connected to each other in a multidrop chain to reduce cabling costs.

ETHERNET: Standard 10Base-T interface with TCP/IP and UDP/IP support.

POWER-OVER-ETHERNET: Power-over-Ethernet (PoE) (IEEE 802.3af) supports 10Base-T Ethernet communications and power over a single CAT5 cable.



The intelligent capabilities of the QTERM-G70 allows it to monitor and adjust the hopper levels of an injection molding machine.

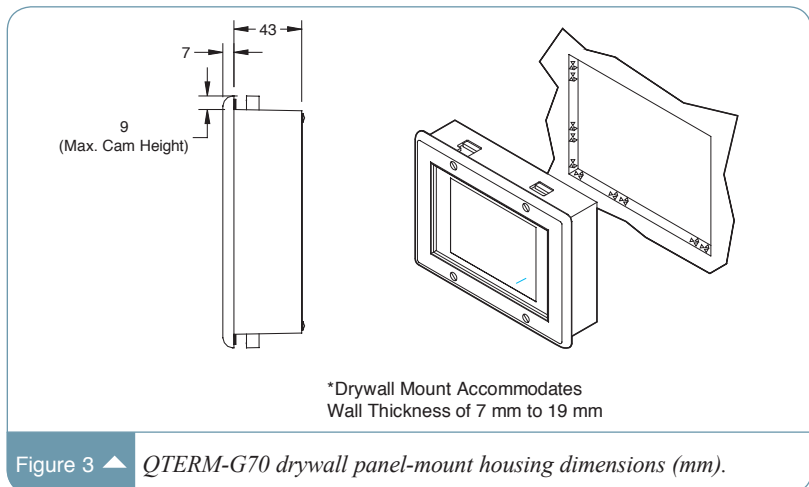

Figure 3 ▲ QTERM-G70 drywall panel-mount housing dimensions (mm).



DISPLAY	Color STN (256 colors) Grayscale (16 shades of gray) transfective FSTN optional Color TFT (256 colors), enhanced color TFT (256 colors) optional Pixels: 320x240 114x86 mm “live area” Dot Pitch: 0.36 mm Contrast: Software-controllable Temperature-compensated Lighting: Cold-cathode fluorescent lamp Brightness is software-controllable
TOUCH SCREEN	Analog-resistive operation Transparent touch area over viewable display Labeled touch area underlay on each side of the display
INTERFACE	EIA-232 serial port with hardware or software handshaking Baud rates: 1200, 2400, 4800, 9600, 14,400, 19,200, 38,400, 57,600 and 115,200 Data formats: 8n1, 8e1, 8o1, 8n2, 7e1, 7o1, 7n2, 7e2 and 7o2 Connector: DB9f serial 8-pin modular (RJ45) with Ethernet and Power-over-Ethernet options Options: Configurable primary and secondary serial ports: EIA-232, EIA-422 or EIA-485 Ethernet 10Base-T or Power-over-Ethernet PS/2 keyboard port (not available with Power-over-Ethernet) option
MEMORY	4 Mbytes flash and 16 Mbytes RAM memory
SPEAKER	Software programmable pitch and duration Audio decoder for .wav file audio support is available as an option
PHYSICAL	Panel-mount configuration Housing: Glass-filled polyester, UL 94V-0 flame rating. Accommodates panels from 0 to 7 mm thick with standard screws Alternate housing supports in-wall mounting using a unique cam system Size: 215x161x50 mm Mass: 1.16 kg Processor: MIPS R3000, RISC 92 MHz
ENVIRONMENTAL	Sealing: NEMA-4 front panel Temperature: Operating -10 to 60 °C (-10 to 50 °C Level 3 legend) Storage -20 to 70 °C Humidity: 0 to 95%, non-condensing Vibration: 5 to 5000 Hz, 4 g RMS Shock: 20 g, 3 ms, any axis
POWER	8 to 26 VDC – 410 mA @ 12 VDC (standard terminal), Power-over-Ethernet (IEEE 802.3af)
SOFTWARE	Qlarity™ – Object-based programming language Qlarity Foundry™ – Windows® design environment
CUSTOMIZING	Outer legend can be customized with your logo/name or graphics. Inner legend underlay around display can be customized with your “keys” and graphics. Internal module available for custom mounting requirements.
CERTIFICATION	FCC Part 15, Class A CE Certified: EN60950:1992, EN55022:1994 FCC Part 15, Subpart B, ICES-003, EN55024:1998

ORDER WORKSHEET 1

Company _____ City / State / Zip _____ / _____ / _____

Address _____ Telephone _____ Fax _____

_____ Email _____

Who do we call with questions (name & phone)? _____

Check ONE box in each of the following groups, then fill in the customizing information you are requesting. A unique part number will be assigned when your worksheet is received.

MAIN CONFIGURATION

- 320x240 Color STN
- **320x240 Grayscale
- * 320x240 Color TFT
- Module, Grayscale
- Module, Color STN

PRIMARY SERIAL PORT

- EIA-232
- EIA-422
- * EIA-485

SECONDARY SERIAL PORT

- None
- * EIA-232
- * EIA-422
- * EIA-485

ETHERNET

- None
- * 10Base-T Ethernet (RJ45)
- * Power-over-Ethernet (IEEE 802.3af)

KEYBOARD

- None
- * PS/2 Keyboard Connection

AUDIO

- Standard Audio
- * Audio (.wav) Decoder

HOUSING

- Standard
- * Drywall Mount

CUSTOMIZING

Inner Legend

- Standard Legend
- * Prototype Legend
- * Custom Legend

Outer Legend

- QSI Logo Legend
- Standard Legend
- * Custom Legend

Legend customization is described in detail in the "Legend Customization" section at the front of this catalog. Refer to "Custom Art Submissions" in the "How to Order" section for custom logo art and special font submission requirements.

STANDARD Standard legend. No customization.

PROTOTYPE Fill out all of the keys you want customized. Specify custom typefaces, colors (Pantone PMS) and logo text or submit your own custom logo. Default text is Black Helvetica Bold typeface.

CUSTOM Fill out all of the keys you want customized. Specify custom typefaces, colors (Pantone PMS) and logo text or submit your own custom logo. Default text is Black Helvetica Bold typeface.

Custom Art Custom Fonts _____ Custom Colors _____

* Extra cost option

** Cost reduction option – minimum quantity required

Approximate color match

ORDER WORKSHEET 2

!!FILL IN APPROPRIATE AREAS FOR CUSTOMIZING!!

NOTE: Legend is not to scale.

