



When it's on the line.™

T402

Stripe® Series Thermal Transfer Printer

User's Guide





T402

Stripe® Series Thermal Transfer Printer

User's Guide



Rev. 3
Customer order # 52007L
Manufacturer part # 52007LB

Proprietary Statement

This manual contains proprietary information of Zebra Technologies Corporation. It is intended solely for the information and use of parties operating and maintaining the equipment described herein. Such proprietary information may not be used, reproduced, or disclosed to any other parties for any other purpose without the expressed written permission of Zebra Technologies Corporation.

Product Improvements

Continuous improvement of products is a policy of Zebra Technologies Corporation. All specifications and signs are subject to change without notice.

FCC Compliance Statement

NOTE: This equipment has been tested and found to comply with the limits for a Class B digital device, pursuant to Part 15 of the FCC Rules. These limits are designed to provide reasonable protection against harmful interference in a residential installation. This equipment generates, uses, and can radiate radio frequency energy and, if not installed and used in accordance with the instructions, may cause harmful interference to radio communications. However, there is no guarantee that the interference will not occur in a particular installation. If this equipment does cause harmful interference to radio or television reception, which can be determined by turning the equipment off and on, the user is encouraged to try to correct the interference by one or more of the following measures:

- n Reorient or relocate the receiving antenna.
- n Increase the separation between the equipment and the receiver.
- n Connect the equipment into an outlet on a circuit different than that to which the receiver is connected.
- n Consult the dealer or an experienced Radio/TV technician for help.

NOTE: This unit was tested with shielded cables on the peripheral devices. Shielded cables must be used with the unit to insure compliance.

“The user is cautioned that any changes or modifications not expressly approved by Zebra Technologies Corporation could void the user’s authority to operate the equipment.”

Canadian DOC Compliance Statement

This digital apparatus does not exceed the Class A limits for radio noise emissions from digital apparatus as set out in the radio interference regulations of the Canadian Department of Communications.

Liability Disclaimer

Zebra Technologies Corporation takes steps to assure that its published Engineering specifications and Manuals are correct; however, errors do occur. Zebra Technologies Corporation reserves the right to correct any such errors and disclaims liability resulting therefrom.

No Liability for Consequential Damage

In no event shall Zebra Technologies Corporation or anyone else involved in the creation, production, or delivery of the accompanying product (including hardware and software) be liable for any damages whatsoever (including, without limitation, damages for loss of business profits, business interruption, loss of business information, or other pecuniary loss) arising out of the use of or the results of use of or inability to use such product, even if Zebra Technologies Corporation has been advised of the possibility of such damages. Because some states do not allow the exclusion or limitation of liability for consequential or incidental damages, the above limitation may not apply to you.

Copyrights

This copyrighted manual and the label printer described herein are owned by Zebra Technologies Corporation. All rights are reserved. Unauthorized reproduction of this manual or the software in the label printer may result in imprisonment of up to one year and fines of up to \$10,000 (17 U.S.C.506). Copyright violators may be subject to civil liability.

All products and brand names are trademarks of their respective companies. All rights reserved.

© 1999 Zebra Technologies Corporation

DECLARATION OF CONFORMITY

I have determined that the Zebra printers identified as the

Stripe[®] Series
DA402 and T402

manufactured by:

Zebra Technologies Corporation
333 Corporate Woods Parkway
Vernon Hills, Illinois 60061-3109 U.S.A.

have been shown to comply with the applicable technical standards of the FCC

for Home, Office, Commercial, and Industrial use

if no unauthorized change is made in the equipment,
and if the equipment is properly maintained and operated.

Chris Kueser

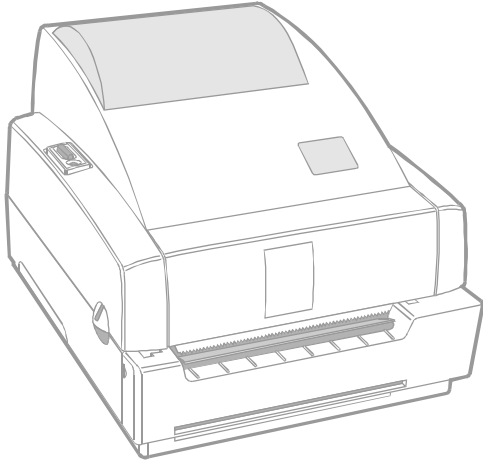

Contents

Introduction

Hello!	1
What's in the Box	1
Unpacking and Inspection.	2
Reporting Damage	2
DC Power Supply	3
Printer Overview (illustration)	4

Getting Ready to Print

Loading the Media.	5
Tear-Off Mode	5
Peel-Off Mode	10
Cutter Mode.	16
Fanfold Media	20
Loading the Ribbon	22
Removing the Ribbon.	24
Auto Calibration	25
Operator Controls	26
Power Switch	26
Feed Button	26
Status LED	26
Printing a Test Label	27
Hooking Up the Printer and Computer.	27
Serial (RS-232) Interface Requirements	27
Parallel Interface Requirements	28
Serial and Parallel Cabling Requirements	28
Communicating with the Printer	29
Via the Parallel Port.	29
Via the Serial Port	29

Using ZPL II	30
Adjusting the Print Width	30
Adjusting the Print Darkness	30
Adjusting the Print Speed	30

Troubleshooting

What the Status LED is Telling You	31
Print Quality Problems	32
Manual Calibration	34
Troubleshooting Tests	35
Printing a Configuration Label	35
Recalibration	35
Resetting the Factory Default Values	36
Communications Diagnostics	36
Feed Button Modes	37

Maintenance

Cleaning	39
Lubrication	39
Parts List	41
Replacing the Printhead	44

Specifications

Printing	45
Ribbon	45
Label/Tag	46
Font/Bar Code	47
Physical/Environmental/Electrical	47
Agency Approvals	48
Options	48
Serial (RS-232) Connector Technical Information	49
Interconnecting to DTE Devices	49
Interconnecting to DCE Devices	49
Parallel Interface Technical Information	52

Index

Introduction

Hello!

Thank you for choosing the Zebra® T402™ Printer. This rugged little printer is certain to become a productive and efficient addition to your workplace!

- n This user's guide gives you all the information you will need to operate and maintain the printer.
- n To create and print label formats, take a look at the *ZPL II Programming Guide* (part #46530L). If one was not ordered with your printer, simply call your distributor *or* visit our web site at www.zebra.com.



NOTE: Many printer settings may also be controlled by your printer's driver or label preparation software. Refer to the driver or software documentation for more information.

What's in the Box

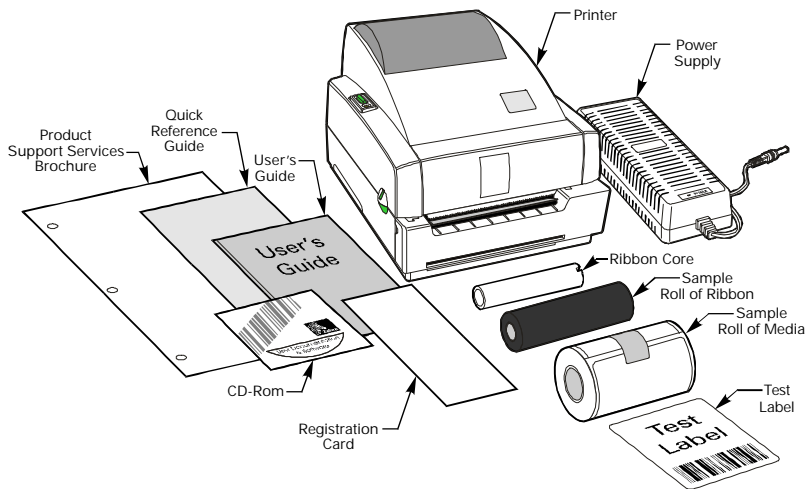

Unpacking and Inspection

Inspect the printer for possible shipping damage:

- n Check all exterior surfaces for damage.
- n Raise the top cover (refer to “[Loading the Media](#)” on page 5) and inspect the media compartment for damage.

In case shipping is required, save the carton and all packing material.

Reporting Damage

If you discover shipping damage:

- n Immediately notify and file a damage report with the shipping company.
Zebra Technologies Corporation is not responsible for any damage incurred during shipment of the printer and will not cover the repair of this damage under its warranty policy.
- n Keep the carton and all packing material for inspection.
- n Notify your authorized reseller.



WARNING: NEVER OPERATE THE PRINTER AND POWER SUPPLY IN AN AREA WHERE THEY CAN GET WET. PERSONAL INJURY COULD RESULT!

DC Power Supply

Refer to Figure 1.

1. The DC power supply has a barrel connector on one end that must be inserted into the power supply receptacle on the back of the printer.
2. Insert the separate AC power cord into the power supply.
3. Plug the other end of the cord into an appropriate AC electrical outlet.

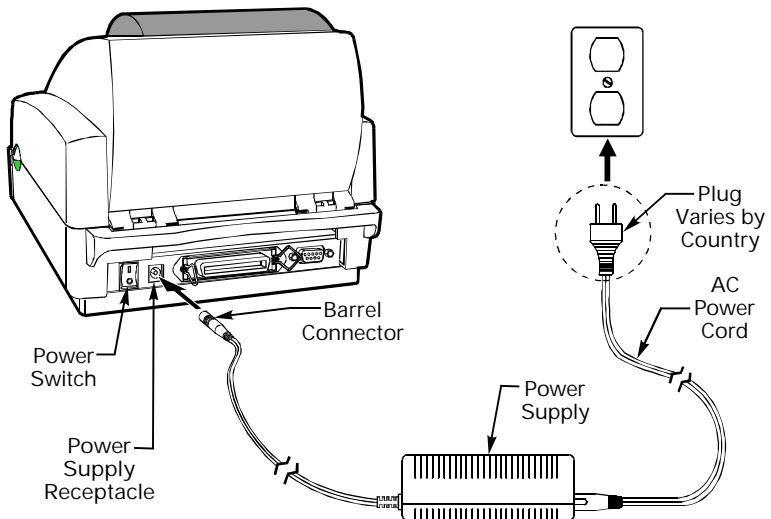

Figure 1

Printer Overview

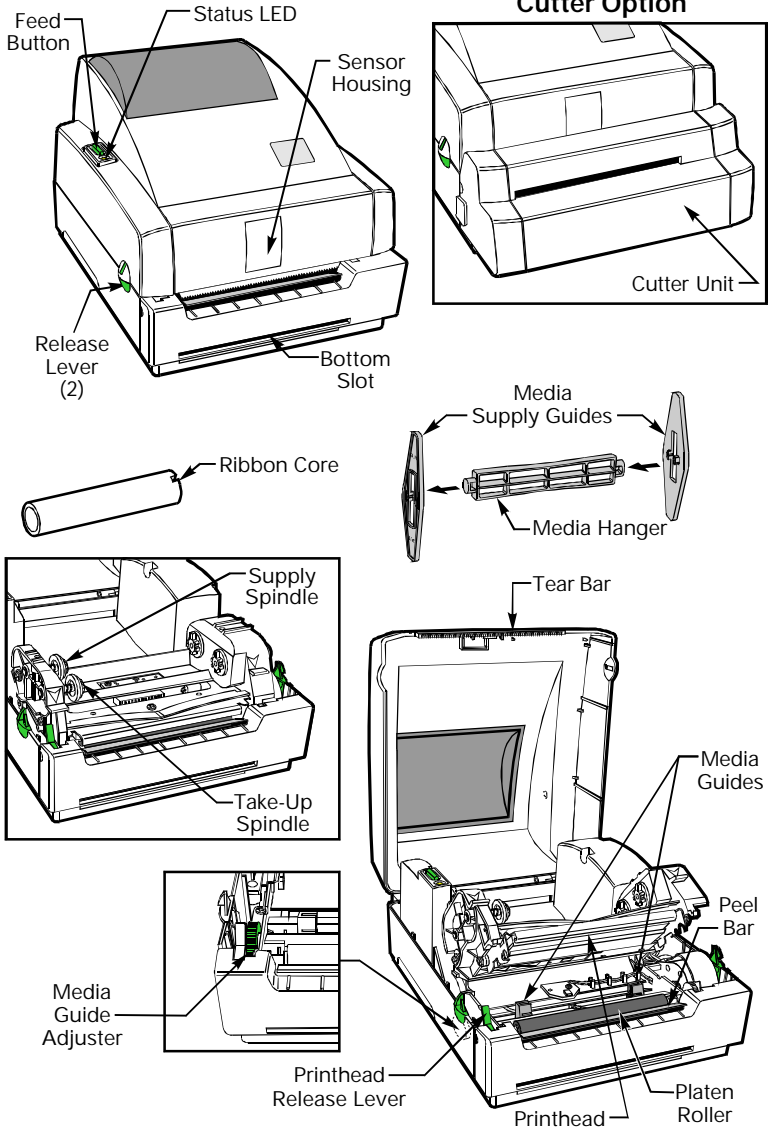

Figure 2

Getting Ready to Print

Loading the Media

You can operate this printer in three different modes: tear-off, peel-off, or with a cutter.

- n Tear-off mode allows you to tear off each label (or a strip of labels) after it is printed.
- n In peel-off mode, the backing material is peeled away from the label as it is printed. After this label is removed, the next one is printed.
- n In cutter mode, the printer automatically cuts the label after it is printed.



NOTE: The cutter is designed to cut through paper labels or the backing between labels, not the adhesive backing of the label. Adhesive build-up on the cutter blade may cause the cutter to jam. See page 39 for [cutter cleaning instructions](#).

Tear-Off Mode

1. Unlatch the top cover by pressing the two green release levers (refer to Figure 3). Then, lift the top cover to expose the media compartment.

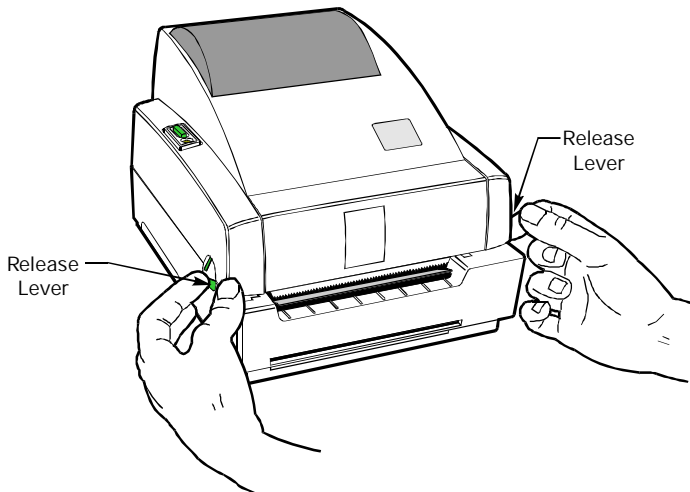

Figure 3

2. Insert one end of the media hanger into one of the media supply guides (refer to Figure 4).
3. Place the roll of media onto the media hanger.
4. Place the second media supply guide onto the other end of the media hanger (refer to Figure 4).



NOTES: The media roll **must** be centered on the media hanger. The media roll should rest against the smooth side of the media supply guides. The textured side marked “out” should face the outside of the printer. The media supply guides should just touch the edges of the roll of media; they must not cause pressure or excessive drag on the media roll.

5. Refer to Figure 5. If you are using labels, make sure the media unwinds from the top of the roll. Tags unwind from the bottom of the roll.
6. Place the media roll in the top cover (refer to Figure 6).
7. Release the printhead by pulling the printhead release lever toward you (refer to Figure 6, “1”).
8. Lift the printhead (refer to Figure 6, “2”) until you feel it “lock” into place. Be careful not to force the printhead past this position!

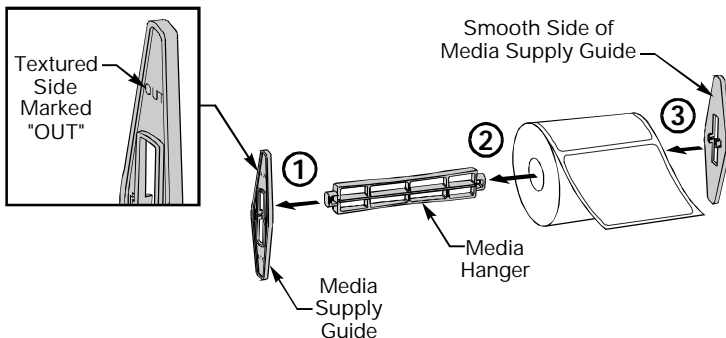

Figure 4

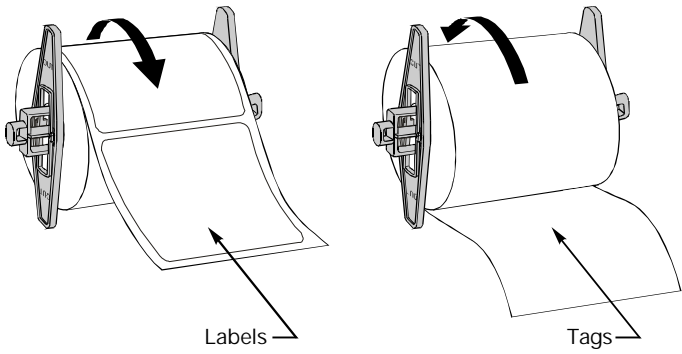

Figure 5

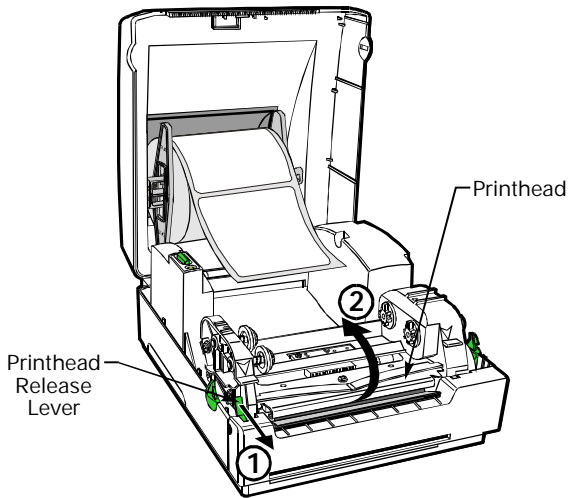

Figure 6

9. Refer to Figure 7. Thread the media through the media guides.



NOTE: If the media guides must be changed to accommodate the width of the media, turn the green media guide adjuster (refer to Figure 7). The media guides should just touch, but not restrict, the edges of the roll.

10. Continue to thread the media past the peel bar (refer to Figure 7).
11. Place the media hanger into the two mounting slots (refer to Figure 8).
12. Close the printhead by pressing down at both arrows (refer to Figure 9).
13. Close the top cover and turn on the printer *or* press the feed button if the printer is already on (see “Auto Calibration” on page 25 for more information).

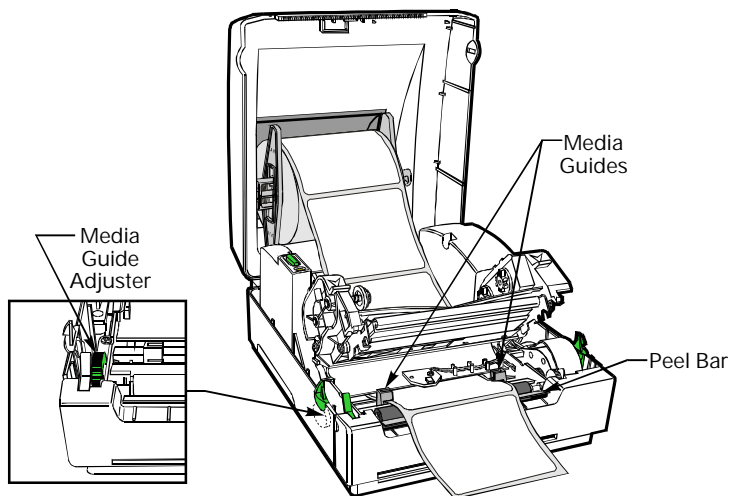

Figure 7

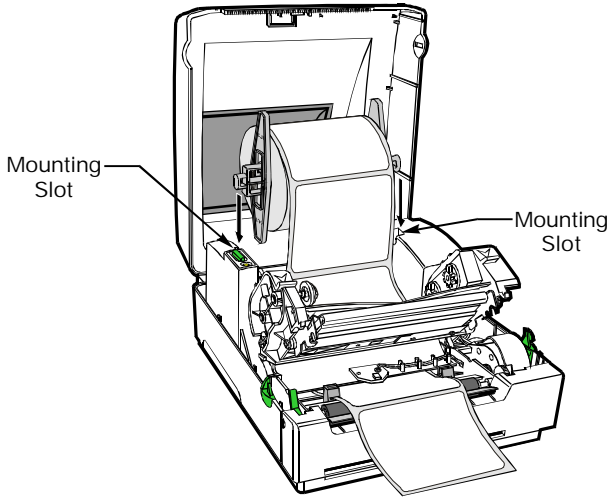

Figure 8

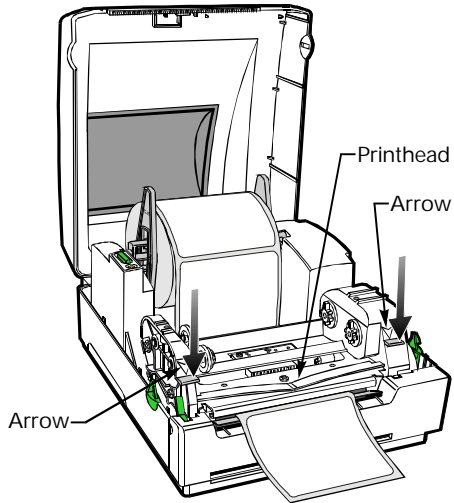

Figure 9

Peel-Off Mode

1. Unlatch the top cover by pressing the two green release levers (refer to Figure 10). Then, lift the top cover to expose the media compartment.
2. Insert one end of the media hanger into one of the media supply guides (refer to Figure 11).
3. Place the roll of media onto the media hanger.
4. Place the second media supply guide onto the other end of the media hanger (refer to Figure 11).



NOTES: The media roll **must** be centered on the media hanger. The media roll should rest against the smooth side of the media supply guides. The textured side marked “out” should face the outside of the printer. The media supply guides should just touch the edges of the roll of media; they must not cause pressure or excessive drag on the media roll.

5. Place the media roll in the top cover (refer to Figure 12).
6. Release the printhead by pulling the printhead release lever toward you (refer to Figure 12, “1”).
7. Lift the printhead (refer to Figure 12, “2”) until you feel it “lock” into place. Be careful not to force the printhead past this position!

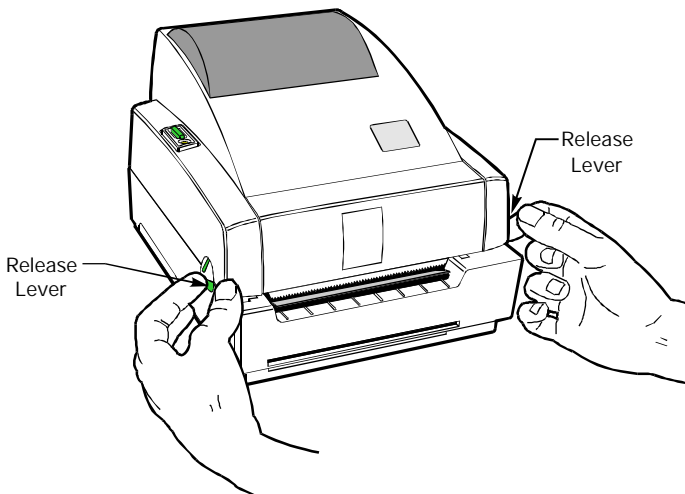

Figure 10

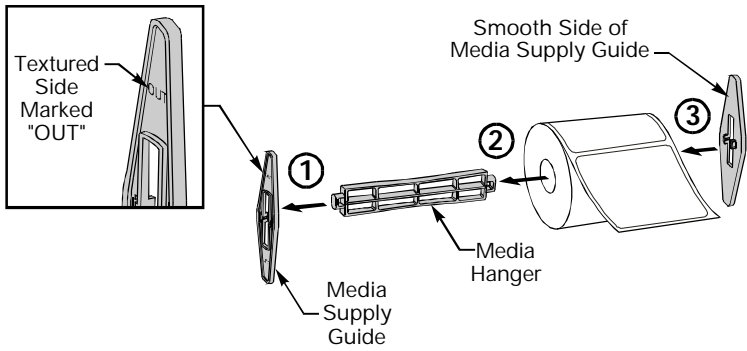

Figure 11

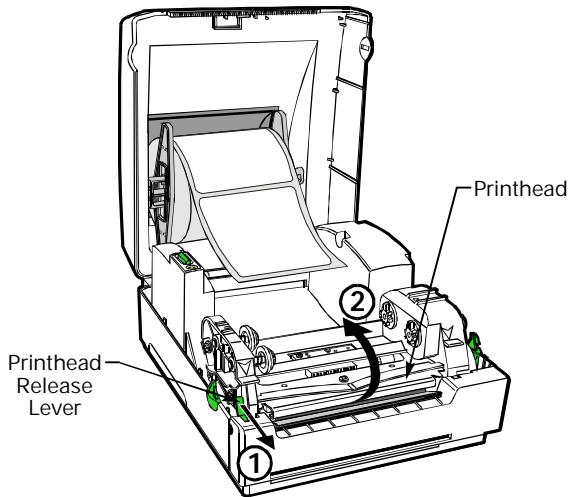



Figure 12

8. Refer to Figure 13. Thread the media through the media guides.

 **NOTE:** *If the media guides must be changed to accommodate the width of the media, turn the green media guide adjuster (refer to Figure 13). The media guides should just touch, but not restrict, the edges of the media roll.*

9. Continue to thread the media until it is approximately 8" (203 mm) past the peel bar (refer to Figure 13).

10. Place the media hanger into the two mounting slots (refer to Figure 14).

11. Remove approximately 6" (152.4 mm) of labels from the backing.

12. Insert the label backing into the peel-off feed slot (refer to Figure 15).

Continue to feed the label backing until it comes out of the bottom slot.

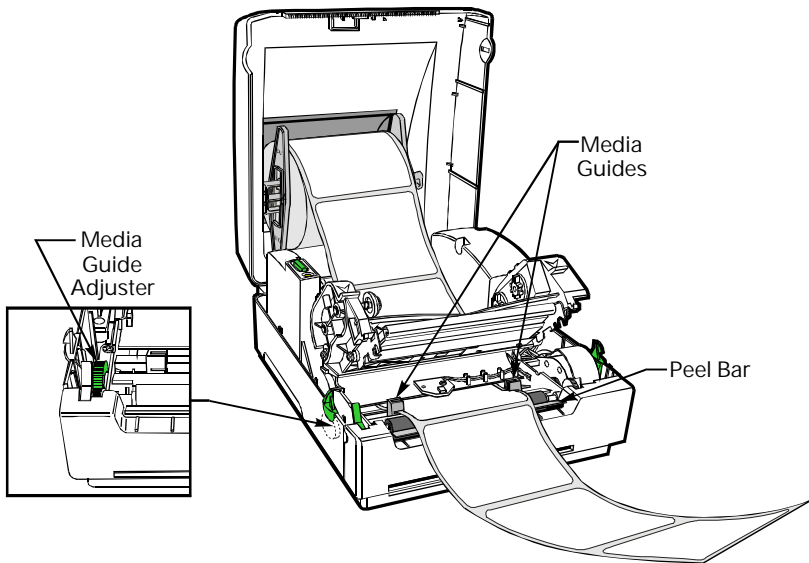

Figure 13

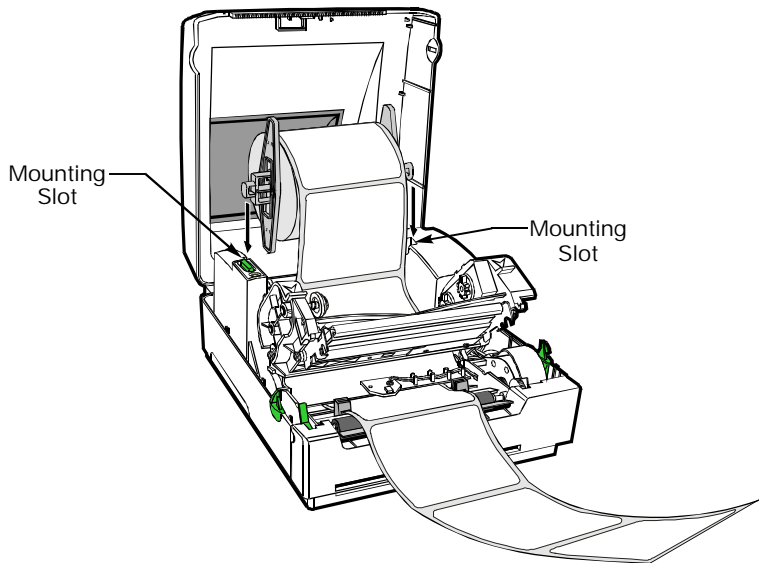

Figure 14

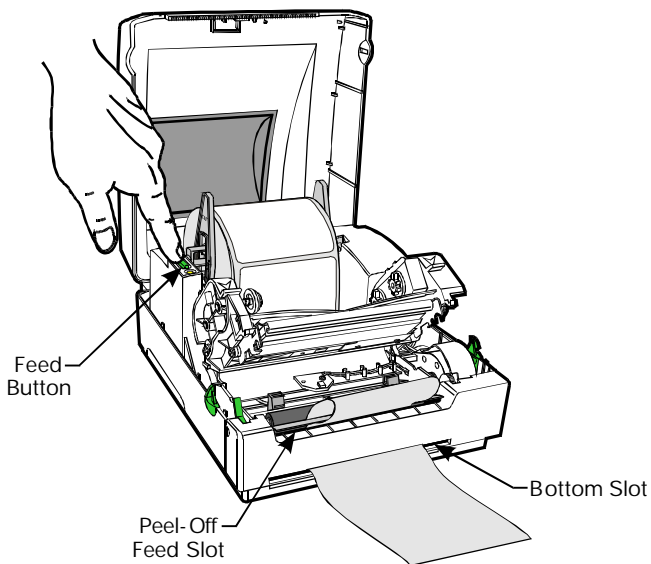

Figure 15

13. Gently pull the label backing to remove any slack in the media.
14. Close the printhead by pressing down at both arrows (refer to [Figure 16](#)).
15. Close the top cover. Activate the label taken sensor by pushing in on the top of the sensor housing until it locks into position (refer to [Figure 17](#)).
16. Turn on the printer *or* press the feed button if the printer is already on (see [“Auto Calibration”](#) on page 25 for more information).

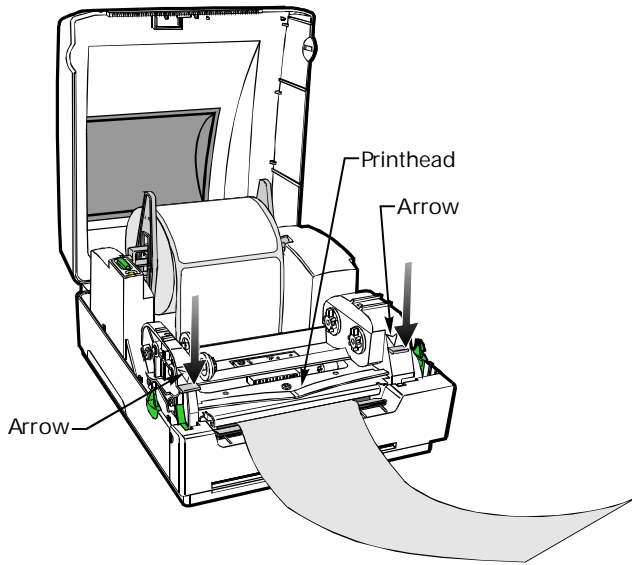

Figure 16

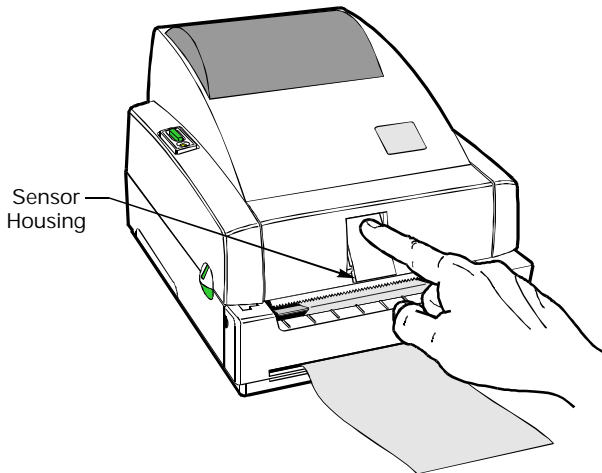

Figure 17

Cutter Mode (optional)

1. Unlatch the top cover by pressing the two green release levers (refer to Figure 18). Then, lift the top cover to expose the media compartment.
2. Insert one end of the media hanger into one of the media supply guides (refer to Figure 19).
3. Place the roll of media onto the media hanger.
4. Place the second media supply guide onto the other end of the media hanger (refer to Figure 19).



NOTES: The media roll **must** be centered on the media hanger. The media roll should rest against the smooth side of the media supply guides. The textured side marked “out” should face the outside of the printer. The media supply guides should just touch the edges of the roll of media; they must not cause pressure or excessive drag on the media roll.

5. Place the media roll in the top cover (refer to Figure 20).
6. Release the printhead by pulling the printhead release lever toward you (refer to Figure 20, “1”).
7. Lift the printhead (refer to Figure 20, “2”) until you feel it “lock” into place. Be careful not to force the printhead past this position!

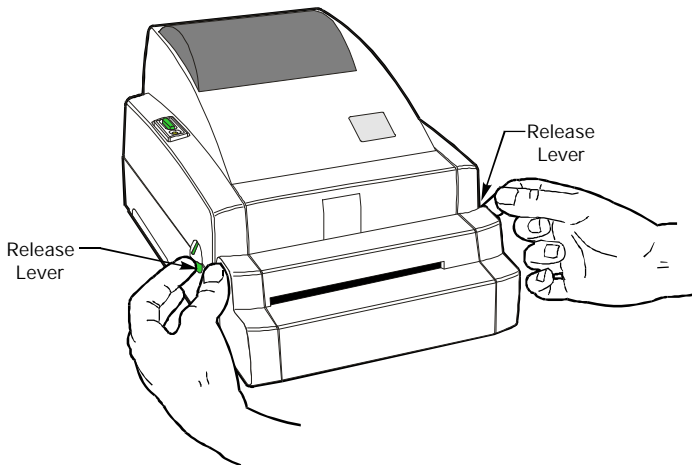

Figure 18

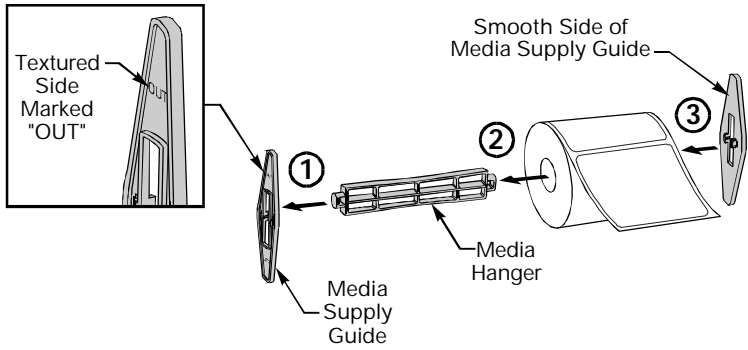

Figure 19

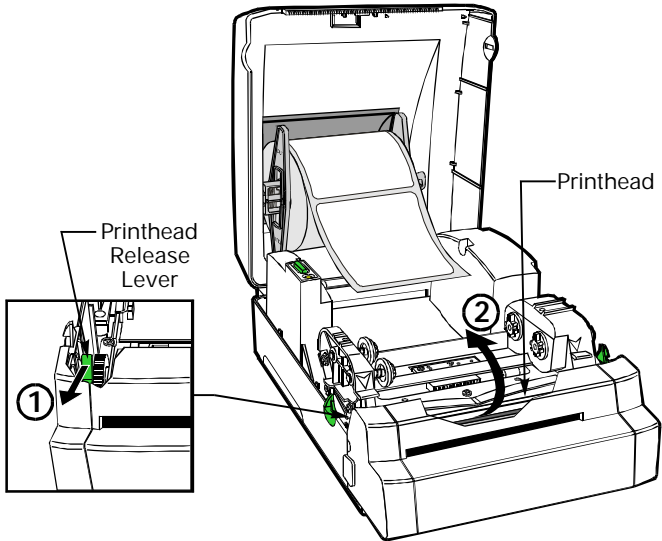



Figure 20

8. Refer to Figure 21. Thread the media through the media guides.

 **NOTE:** *If the media guides must be changed to accommodate the width of the media, turn the green media guide adjuster (refer to Figure 21). The media guides should just touch, but not restrict, the edges of the roll*

9. Refer to Figure 21. Thread the media through the cutter unit.

10. Place the media hanger into the two mounting slots (refer to [Figure 22](#)).

11. Close the printhead by pressing down at both arrows (refer to [Figure 23](#)).

12. Close the top cover and turn on the printer *or* press the feed button if the printer is already on (see [“Auto Calibration”](#) on page 25 for more information).

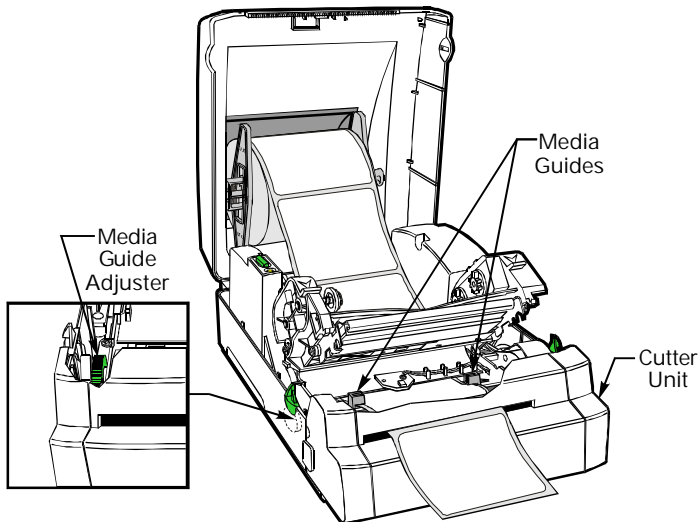

Figure 21

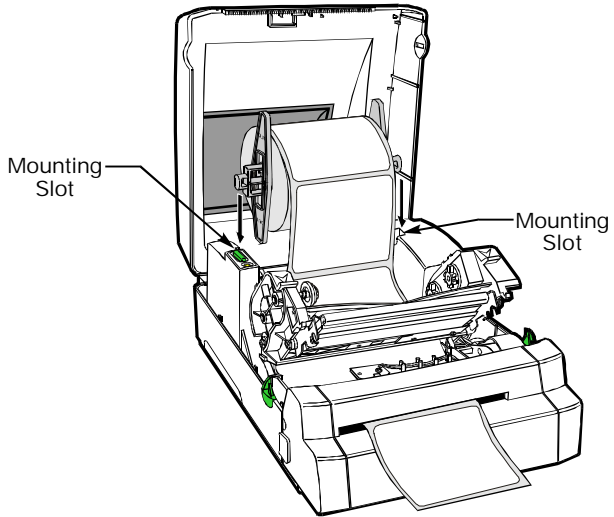

Figure 22

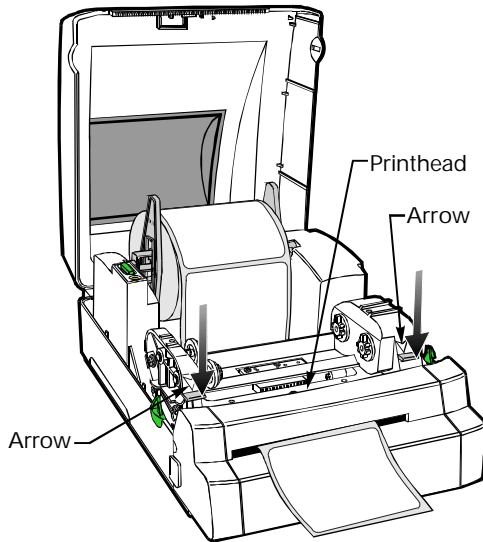

Figure 23

Fanfold Media

Fanfold media loads from the outside of the printer.

1. Thread the media through the access slot in the back of the printer (refer to [Figure 24](#)).
2. Open the top cover.
3. Release the printhead by pulling the printhead release lever toward you (refer to [Figure 24](#), “1”).
4. Lift the printhead (refer to [Figure 24](#), “2”) until you feel it “lock” into place. Be careful not to force the printhead past this position!
5. Refer to [Figure 25](#). Thread the media through the media guides.



NOTE: *If the media guides must be changed to accommodate the width of the media, turn the green media guide adjuster (refer to [Figure 25](#)). The media guides should just touch, but not restrict, the edges of the roll.*

6. Continue to thread the media past the peel bar (refer to [Figure 25](#)).
7. Close the printhead by pressing down at both arrows (refer to [Figure 25](#)).
8. Close the top cover and turn on the printer *or* press the feed button if the printer is already on (see “[Auto Calibration](#)” on page 25 for more information).

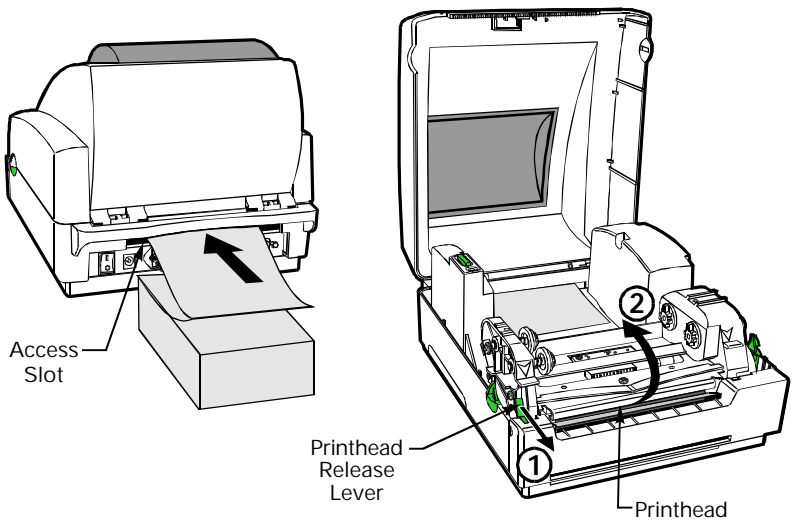

Figure 24

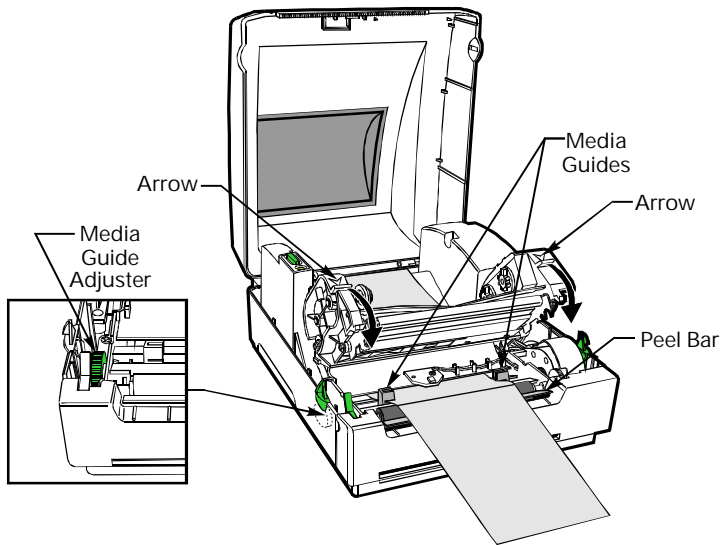

Figure 25

Loading the Ribbon

Figure 26 shows the location of the ribbon supply spindle, ribbon take-up spindle, and ribbon supply slot.

1. Open the top cover.
2. Install an empty ribbon core (notched end to the right) as shown in [Figure 27](#). This becomes the ribbon take-up spindle.
3. Remove the tape that secures the leader on the new roll of ribbon.
4. Install the ribbon roll on the ribbon supply spindle (refer to [Figure 27](#)). Make sure the ribbon unwinds over the top of the roll and feeds toward the back of the printer.
5. Open the printhead by pulling the printhead release lever toward you.
6. Lift the printhead until you feel it “lock” into place. Be careful not to force the printhead past this position!
7. Thread the ribbon leader into the ribbon supply slot (refer to [Figure 26](#) for the location of the supply slot).
8. Wrap the ribbon leader around the printhead (refer to [Figure 28](#)). Then, affix the ribbon leader to the ribbon take-up spindle with tape.
9. Wind the ribbon onto the ribbon take-up spindle until the ribbon leader is no longer visible.

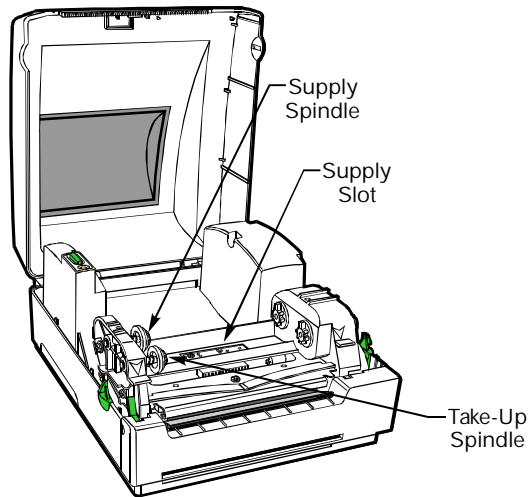

Figure 26

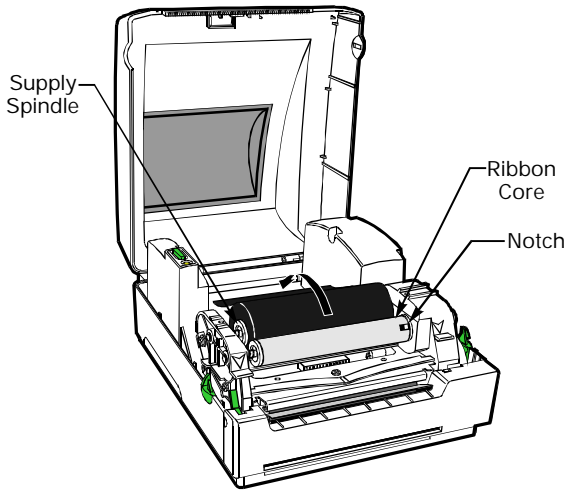

Figure 27

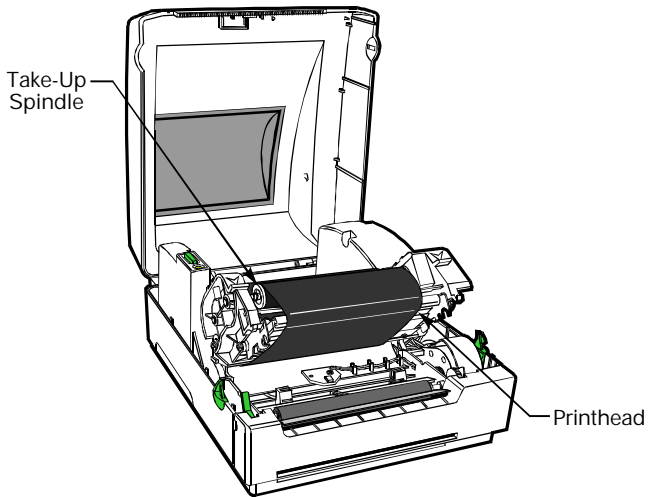

Figure 28

10. Close the printhead by pressing down at both arrows.
11. Close the top cover and turn on the printer *or* press the feed button if the printer is already on (see “Auto Calibration” on page 25 for more information).

Removing the Ribbon

1. Open the printhead.
2. Cut the ribbon below the ribbon take-up spindle (refer to Figure 29).
3. Remove the roll of unused ribbon.



Hint: Tape the end of the ribbon to prevent the roll from unwrapping.

4. Remove the ribbon take-up spindle. Remove and discard the spent ribbon from the core.
5. Keep the core for future use.

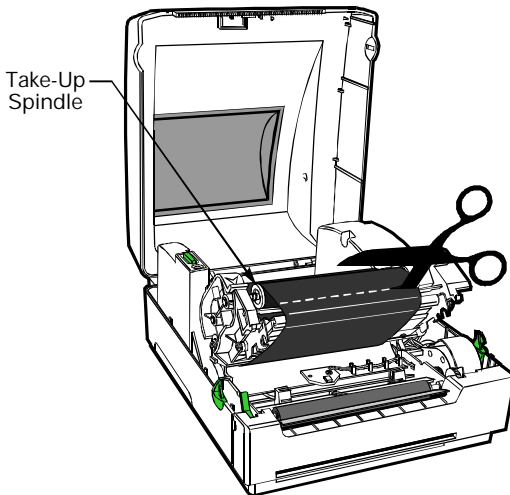

Figure 29

Auto Calibration



NOTE: *If you are using pre-printed labels, pre-printed label backing, or continuous media, see “[Manual Calibration](#)” on page 34.*

An auto calibration is performed when the printer is turned on (if media is loaded) or after an error is cleared. When it is auto calibrating, the printer sets the sensor levels for, and determines the length of, the label you are using.

If the status LED flashes red, refer to “[Manual Calibration](#)” on page 34.

Operator Controls

Refer to Figure 30.

Power Switch

- n Press to turn on and turn off the printer.



CAUTION: *The power should be turned off before connecting or disconnecting the communications and power cables.*

Feed Button

- n Forces the printer to feed one blank label.
- n When printing, puts the printer into a “pause” condition.
- n Takes the printer out of a “pause” condition. (The printer is put into “pause” by either a ZPL II command or an error condition.) See [“What the Status LED is Telling You”](#) on page 31.
- n Used for printer setup and status (see [“Feed Button Modes”](#) on page 37).

Status LED

- n Functions as a printer operational indicator (see [“What the Status LED is Telling You”](#) on page 31).

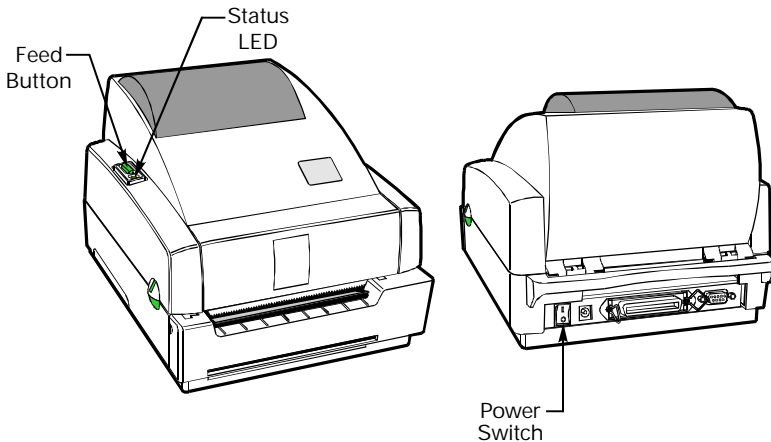

Figure 30

Printing a Test Label

Before you connect the printer to your computer, make sure that the printer is in proper working order. You can do this by printing a configuration label:

1. Make sure the media is properly loaded and the top cover of the printer is closed. Then, turn the printer power on if you have not already done so.
2. When the status LED is solid green, press and hold the feed button until the status LED flashes once.
3. Release the feed button. A configuration label will print.

If you cannot get this label to print, refer to [Troubleshooting](#).

Hooking Up the Printer and Computer



CAUTION: The power supply barrel connector must be inserted into the power supply receptacle on the back of the printer before connecting or disconnecting the communications cables. (If necessary, refer to [Figure 1](#).)

This printer comes with both a nine-pin Electronics Industries Association (EIA) RS-232 serial data interface and an IEEE 1284 bidirectional parallel data interface. In either case, you must supply the required interface cable for your application.



CAUTION: This printer complies with FCC “Rules and Regulations,” Part 15, for Class B Equipment, using fully shielded six-foot data cables. Use of longer cables or unshielded cables may increase radiated emissions above the Class B limits.

Serial (RS-232) Interface Requirements

The required cable must have a nine-pin “D” type (DB-9P) male connector on one end, which is plugged into the mating (DB-9S) serial port located on the back of the printer (refer to [Figure 31](#)). The other end of this serial interface cable connects to a serial port at the host computer. Depending on the specific interface requirements, this will most likely be a null modem cable.

For [pinout and technical information](#), refer to page 49.

Parallel Interface Requirements

The required cable (IEEE 1284-compliant is recommended) must have a standard 36-pin parallel connector on one end, which is plugged into the parallel port located on the back of the printer (refer to Figure 31). The other end of the parallel interface cable connects to the printer connector at the host computer.

For [pinout information](#), refer to page 52.

Serial and Parallel Cabling Requirements

Data cables must be of fully shielded construction and fitted with metal or metalized connector shells. Shielded cables and connectors are required to prevent radiation and reception of electrical noise.

To minimize electrical noise pickup in the cable:

- n Keep data cables as short as possible (6' [1.83 m] recommended).
- n Do not tightly bundle the data cables with power cords.
- n Do not tie the data cables to power wire conduits.

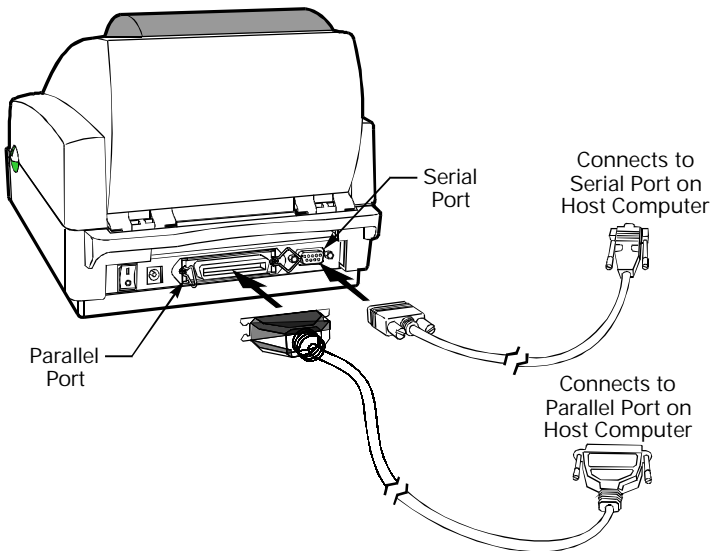

Figure 31

Communicating with the Printer

Via the Serial Port

Serial communications between the printer and the host computer can be set by either autobaud synchronization or the ^SC command.

Autobaud

Autobaud synchronization allows the printer to automatically match the communications parameters of the host computer. To autobaud:

1. Press and hold the feed button until the green status LED flashes once, twice, then three times.
2. While the status LED flashes, send a ZPL II format to the printer.
3. When the printer and host are synchronized, the LED changes to solid green. (No labels will print during autobaud synchronization.)

^SC

Use the Set Communications (^SC) command to change the communications settings on the printer.

1. With the host computer set at the **same** communications settings as the printer, send the ^SC command to change the printer to the desired settings.
2. Change the host computer settings to match the printer settings.

Refer to the *ZPL II Programming Guide* for more information about this command.

Setting the Communications Parameters

To reset the communications parameters on the printer to the factory defaults (9600 baud, 8 bit word length, no parity, 1 stop bit, and XON/XOFF), do the following:

1. Press and hold the feed button until the green status LED flashes once, twice, and then three times.
2. While the status LED flashes, press the feed button.

Via the Parallel Port

Typically, no setup is required once the cable is plugged in. If you should encounter any problems, consult the user's guide that came with your computer.

Using ZPL II

For information about creating labels using ZPL II, refer to the *ZPL II Programming Guide* or visit our web site at www.zebra.com.

Adjusting the Print Width

Print width must be calibrated when:

- n You are using the printer for the first time.
- n There is a change in the width of the media.

Print width may be set by way of the five-flash sequence in “[Feed Button Modes](#)” (see page 37) or refer to the Print Width (^PW) command (consult your *ZPL II Programming Guide*).

Adjusting the Print Darkness

The relative darkness setting is controlled by either the six-flash sequence in “[Feed Button Modes](#)” (see page 37) or the Set Darkness (~SD) command (follow the instructions in the *ZPL II Programming Guide*).

Adjusting the Print Speed

Print quality is affected by print speed *and* the media you are using. Only by experimenting will you find the optimal mix for your application.

If you find that the print speed needs to be adjusted, refer to the Print Rate (^PR) command in the *ZPL II Programming Guide*.

Troubleshooting

What the Status LED is Telling You

Status LED Condition and Color	Printer Status	For a Resolution, Refer to:
Off	Off	1
Solid Green	On	2
Flashing Yellow	Stopped	3
Flashing Green	Normal Operation	4
Flashing Red	Stopped	5
Double Flashing Green	Paused	6
Solid Yellow	Various	7
Alternately Flashing Green and Red	Needs Service	8

RESOLUTIONS:

1. The printer is not receiving power.
 - n Have you turned on the printer power?
 - n Check power connections from the wall outlet to the power supply, and from the power supply to the printer.
2. The printer is on.
3. The printer has failed its power on self test (POST).
 - n If the error occurs right after you turn on the printer, contact an authorized reseller for assistance.

There is a shortage of memory.

- n If this error occurs after you have been printing, turn the printer power off and on. Then, resume printing.
4. The printer is receiving data.
 - n As soon as all of the data has been received, the status LED will turn green; then, the printer automatically resumes operation.

5. The media or ribbon is not loaded.
 - n Load a roll of media or ribbon, following the instructions in “[Loading the Media](#)” on page 5 or “[Loading the Ribbon](#)” on page 22. Then, press the feed button to resume printing.

The printhead is open.

 - n Close the top cover. Then, press the feed button to resume printing.

The cutter is jammed.

 - n Turn off the printer and remove any jammed labels from the cutter unit. Then, turn on the printer to resume printing.
6. The printer is paused.
 - n Press the feed button to resume printing.
7. The printhead is under temperature.
 - n Continue printing while the printhead reaches the correct operating temperature.

The printhead is over temperature.

 - n Printing will stop until the printhead cools to an acceptable printing temperature. When it does, the printer will resume operation.
8. FLASH memory is not programmed.
 - n Return the printer to an authorized reseller.

Print Quality Problems

No print on the label.

- n Are the media and ribbon loaded correctly? Follow the instructions in “[Loading the Media](#)” on page 5 and “[Loading the Ribbon](#)” on page 22.

The printed image does not look right.

- n The printhead is dirty. [Clean the printhead](#) according to the instructions on page 39.
- n The printhead is under temperature.
- n Adjust the print darkness and/or print speed. Refer to the six-flash sequence in “[Feed Button Modes](#)” on page 37, and/or the ^PR and ~SD commands in the *ZPL II Programming Guide*.
- n The media being used is incompatible with the printer. Be sure to use the recommended media for your application, and *always* use Zebra-approved labels and tags.

There are long tracks of missing print (blank vertical lines) on several labels.

- n The printhead is dirty. [Clean the printhead](#) according to the instructions on page 39.
- n The printhead elements are damaged. Replace the printhead (see [“Replacing the Printhead”](#) on page 44).

The printing does not start at the top of the label, or misprinting of one to three labels.

- n The media may not be threaded under the media guides. Refer to [“Loading the Media”](#) on page 5.
- n The printer needs to be calibrated. Refer to [“Auto Calibration”](#) on page 25.
- n The correct media sensor may not be activated. Manual calibration selects the media sensing method for the labels being used (refer to the ^MN command in the *ZPL II Programming Guide*).
- n Verify that the Label Top (^LT) command is correctly set for your application (consult the *ZPL II Programming Guide*).

A label format was sent to, but not recognized by, the printer.

- n Is the printer in pause mode? If so, press the feed button.
- n If the status LED is on or flashing, refer to [“What the Status LED is Telling You”](#) on page 31.
- n Make sure the data cable is correctly installed.
- n A communications problem has occurred. First, make sure that the correct communications port on the computer is selected. Next, verify that the same handshaking is in use by both the printer and the computer. Then, ensure that the baud rates of the printer and the computer match. Refer to [“Communicating with the Printer”](#) on page 29.

Manual Calibration

A manual calibration should be performed whenever you are using pre-printed labels (or label backing) *or* if the printer will not correctly auto calibrate.

1. Turn on the printer power.
2. Remove approximately 6" (152 mm) of labels from a section of backing material. Load the media so that only the backing material is threaded through the printer and under the printhead.
3. Use the Media Tracking (^MN) command to select the appropriate media type (refer to the *ZPL II Programming Guide*).
4. Press and hold the feed button until the green status LED flashes once, then twice. Release the feed button.
5. The printer will set the media sensor for the label backing being used. After it is done making this adjustment, the roll will automatically feed until a label is positioned at the printhead.
6. A profile of the media sensor settings (similar to the example in Figure 32) will print. Upon completion, the printer will save the new settings in memory and the printer is ready for normal operation.
7. Press the feed button. One entire blank label should feed. If this does not happen, try defaulting (refer to the four-flash sequence in "[Feed Button Modes](#)" on page 37) and recalibrating the printer.



NOTE: *Performing a manual calibration disables the auto calibration function. To return to auto calibration, default the printer (see the four-flash sequence in "[Feed Button Modes](#)" on page 37).*

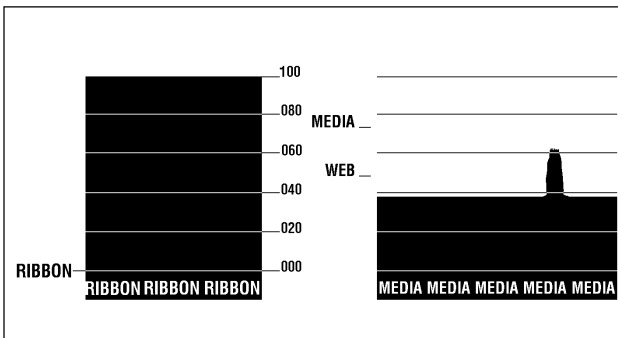

Figure 32

Troubleshooting Tests

Printing a Configuration Label

To print out a listing of the printer's current configuration (an example is shown in Figure 33), refer to the one-flash sequence in “[Feed Button Modes](#)” on page 37.

Recalibration

Recalibrate the printer if it starts to display unusual symptoms, such as skipping labels. See “[Auto Calibration](#)” on page 25.

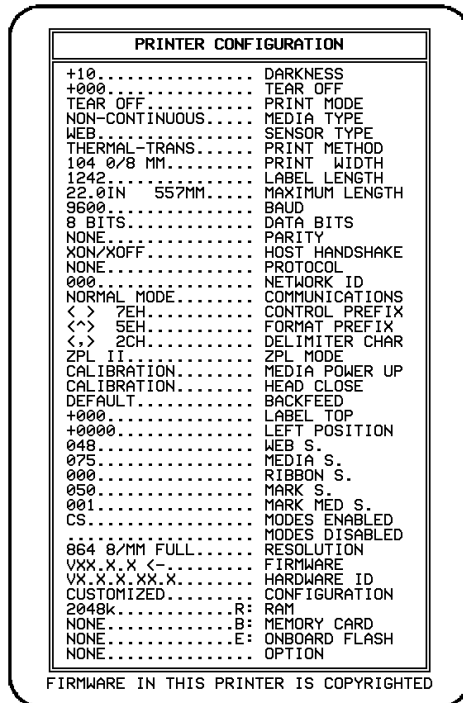

Figure 33

Resetting the Factory Default Values

Sometimes, resetting the printer to the factory defaults solves some of the problems. Follow the four-flash sequence instructions in “[Feed Button Modes](#)” on page 37.

Communications Diagnostics

If there is a problem transferring data between the computer and printer, try putting the printer in the communications diagnostics mode. The printer will print the ASCII characters and their respective hexadecimal values (see Figure 34) for any data received from the host computer. To find out how, refer to the power off mode procedure in “[Feed Button Modes](#)” on page 37.

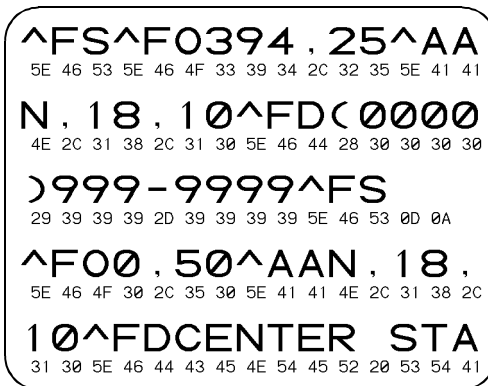
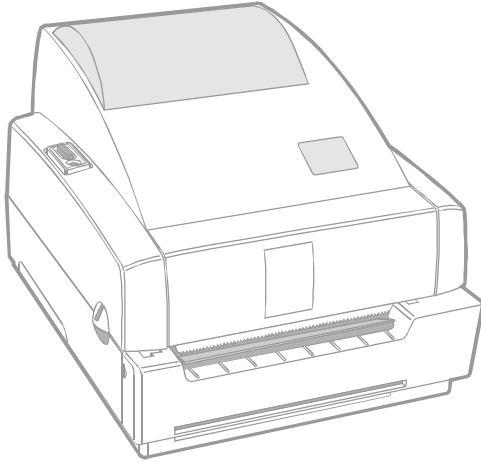

Figure 34

Feed Button Modes

Power Off Mode (Communications Diagnostics Mode)	
<p>With the printer power off, press and hold the feed button while you turn on the power. The printer prints out a listing of its current configuration (see Figure 33). After printing the label, the printer automatically enters a diagnostic mode in which the printer prints out a literal representation (see Figure 34) of all data subsequently received. To exit the diagnostic mode and resume printing, turn off and then turn on the printer.</p>	
Power On Modes	
<p>With the printer power on and top cover closed, press and hold the feed button for several seconds. The green status LED will flash a number of times in sequence. The explanation at the right (Action) shows what happens when you release the key after the specific number of flashes.</p>	
Flash Sequence	Action
*	A configuration label prints.
* **	The media sensor calibrates and a media sensor profile prints (see Manual Calibration and Figure 32 on page 34).
* ** ***	<p>To reset the communications parameters: Press and release the feed button while the LED flashes. The serial communication parameters reset to 9600 baud, 8 bits per character, no parity, 1 stop bit, and XON/XOFF.</p> <p>For autobaud synchronization: Send a ZPL II format to the printer while the LED flashes. When the printer and host are synchronized, the LED changes to solid green. Note: <i>No labels print during autobaud synchronization.</i></p>
* ** *** ****	Resets the factory defaults, auto calibrates, and saves settings into memory.
* ** *** **** *****	The print width calibrates. While the status LED alternately flashes green and yellow, a series of stacking rectangles print on the label. When the rectangle prints to the outer edges of the label, press and release the feed button. The label width and current communications parameters will be saved into memory.
* ** *** **** ***** *****	The print darkness calibrates. A series of nine samples print, starting with the lightest and ending with the darkest image. When the desired print darkness is achieved, press and release the feed button. The print darkness will be saved into memory.
<p>If the feed button remains pressed after a 7-flash sequence, the printer will ignore the button when it is released.</p>	



Maintenance

Cleaning



CAUTION: Use only the cleaning agents indicated. Zebra Technologies Corporation will not be responsible for damage caused by any other cleaning materials used on this printer.

If necessary, refer to [Figure 2](#) for part locations.

Area	Method	Interval
Printhead	After allowing the printhead to cool for approximately one minute, use 70% isopropyl alcohol on a cotton swab to clean the print elements from end to end (the print elements are located in the thin gray line on the printhead). Note: You do not have to turn off the printer to do this. If print quality has not improved after performing this procedure, try cleaning the printhead with Save-a-Printhead cleaning film. This specially coated material removes contamination buildup without damaging the printhead. Call your authorized reseller for more information.	After every five rolls of media or ribbon
Platen roller	Manually rotate the platen roller. Clean it thoroughly with 70% isopropyl alcohol and a cotton swab or lint-free cloth.	
Peel bar	Clean it thoroughly with 70% isopropyl alcohol and a cotton swab.	As needed
Tear bar	Clean it thoroughly with 70% isopropyl alcohol and a cotton swab.	As needed
Cutter	Turn the printer power off. Use tweezers to remove the media. Never use solutions or solvents to clean the blade, as blade lubrication and sharpness may be effected.	As needed
Exterior	Water-dampened cloth	As needed
Interior	Brush/air blow	As needed

Lubrication



CAUTION! No lubricating agents of any kind should be used on this printer! Some commercially available lubricants, if used, will damage the finish and the mechanical parts inside the printer.

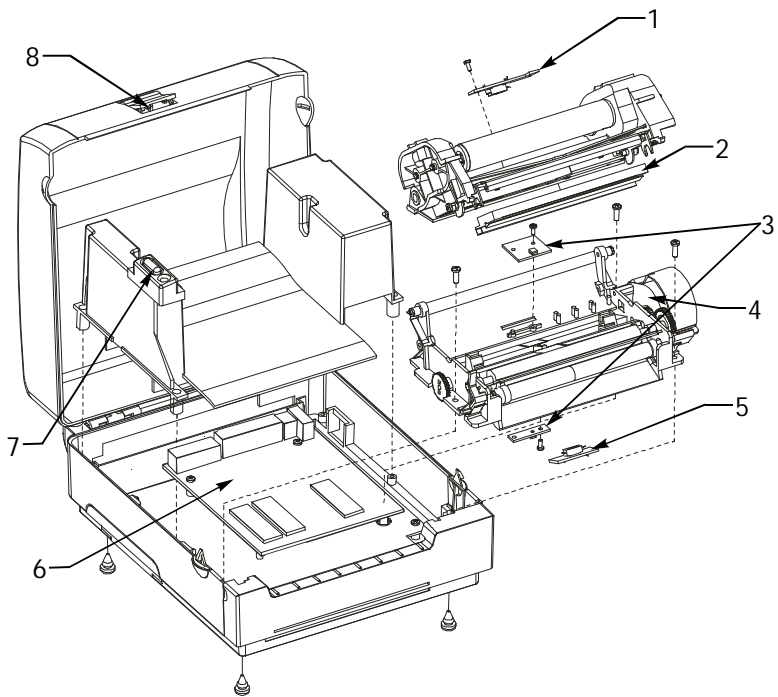

Figure 35

Parts List

Refer to [Figure 35](#).

Item Number	Description	Part Number
1	Ribbon Detector Sensor Kit (set of 3)	105903-026
2	Printhead Assembly (4")	105950-020
	Printhead Cable (set of 5)	105903-028
3	Media Gap Sensor Kit (4") (set of 2)	105903-029
4	Stepper Motor	105903-132
5	Blackline Media Sensor Kit (set of 3)	105903-003
6	Main Logic Board Maintenance Kit	52050M
7	Feed Switch Assembly (set of 5)	105903-015
8	Peel-Off Sensor Assembly (set of 3)	105903-039
Not Shown	Cutter	105903-073
	Universal Power Supply Assembly (90-264 VAC, 47-63 Hz)	808080-001
	Power Cord, 110V (set of 5)	105950-038
	Power Cord, 230V European (set of 5)	105950-039
	Power Cord, 230V UK (set of 5)	105950-040
	Power Cord, 230V Australian (set of 5)	105950-041
	8M FLASH Memory w/Real Time Clock Option Kit	52054
	User's Guide	52007L
	Quick Reference Guide	52008L

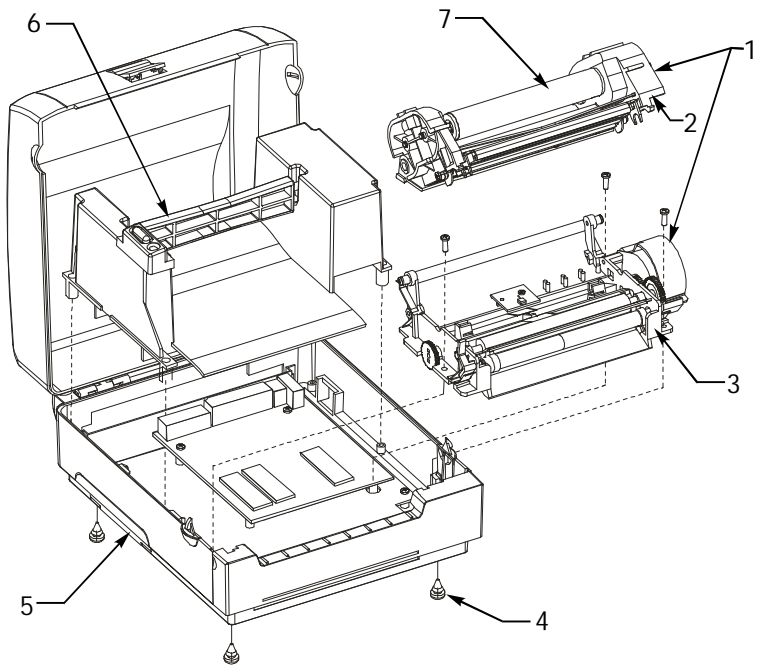

Figure 36

Refer to [Figure 36](#).

Item Number	Description	Part Number
1	Print Mechanism Assembly	105903-131
2	Upper Frame w/Ribbon Handler Kit	105903-049
3	Lower Frame Kit	105903-050
4	Rubber Foot Kit (set of 100)	105903-019
5	Option Port Cover (set of 20)	105903-051
6	Media Roll Holder Kit (set of 5)	105903-065
7	4" Notched Ribbon Core	105903-053
Not Shown	Battery Pack Adapter Plate	105903-022
	Ribbon Clutch Assembly	105903-080
	Printhead Tension Bar	105903-082
	Hardware Kit	105903-079

Replacing the Printhead

Refer to Figure 37.

1. Release the printhead by pulling the printhead release lever toward you.
2. Lift the printhead until you feel it “lock” into place. Be careful not to force the printhead past this position!
3. Remove the screw that secures the printhead to the upper frame.
4. Remove the printhead wire harness connector from the receptacle.
5. Insert the printhead wire harness connector into the receptacle of the new printhead. Make sure the connector is fully seated in the receptacle.
6. Correctly position the printhead into the upper frame.
7. While holding the printhead in place, reinstall the screw that secures the printhead to the upper frame.

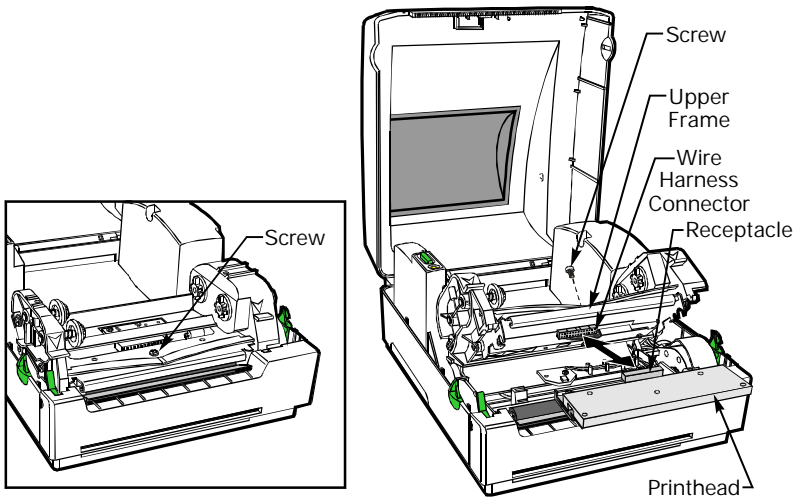

Figure 37

Specifications



NOTE: Printer specifications are subject to change without notice.

Printing Specifications

Print Density	203 dots/inch (8 dots/mm)
Print Speed (per second)	Tear-off and cutter: 1.5" (38 mm), 2" (51 mm), and 2.5" (64 mm) Peel-off: 1.5" (38 mm) and 2" (51 mm)
Print Width	1.12" to 4.09" (28 mm to 104 mm)
Print Length	.005" to 22" (.125 mm to 559 mm) with standard memory
Registration Tolerance	Horizontal: +/- 0.0591" (1.5 mm) Vertical: +/- 0.0393" (1 mm)
FLASH Memory (User Available)	1 MB
DRAM Memory (User Available)	1 MB

Ribbon Specifications

Ribbon Width	1.3" (33 mm) to 4.3" (109 mm)	
Ribbon Length	Approximately 3600" (91 m)	
Ribbon Roll (Maximum Outer Diameter)	1.39" (35 mm)	
Notched Core	Inner Diameter	0.5" (13 mm)
	Outer Diameter	0.75" (19 mm)

Label/Tag Specifications

Label/Tag Width		1.12" to 4.65" (28 mm to 118 mm)
Label/Tag Length		0.38" to 22" (10 mm to 559 mm) with standard memory 0.5" (13 mm) to 22" (559 mm) in peel-off mode
Interlabel Gap		0.08" to 0.16" (2 mm to 4 mm) Recommended: 0.118" (3 mm)
Label/Tag Thickness		.003" to .0075" (.08 mm to .19 mm)
Label Roll Size	Max. Outer Diameter	5" (127 mm)
	Inner Core	1" (25.4 mm)
Media Requirements		<ul style="list-style-type: none"> ✓ Use Zebra-brand thermal transfer media that is outside wound. Media may be reflective (black mark) sensing or transmissive sensing, die-cut, notched, or continuous. ✓ For die-cut labels, use only full auto dies. ✓ Notched media must have a 0.5" (13 mm) wide x 0.094" (2.4 mm) long cutout located in the center of the roll. The reflective media black marks must be located in the center of the roll. <p>Minimum Black Mark Dimensions:</p> <ul style="list-style-type: none"> ✓ Mark width: 0.5" (13 mm) centered and perpendicular to the edge of the media. ✓ Mark length: 0.094" (2.4 mm) parallel to the bottom of the media.

Font/Bar Code Specifications

Fonts Available	<ul style="list-style-type: none"> ✓ CG Triumvirate Bold Condensed scaleable smooth (0) ✓ Zebra fonts A-H, GS, P-V ✓ IBM Code Page 850 International Symbols 	
Bar Codes Available (1D)	<ul style="list-style-type: none"> ✓ Codabar (supports ratios of 2:1 to 3:1) ✓ Code 11 ✓ Code 128/USD 8 (supports serialization in all subsets and UCC Case Codes) ✓ Code 39 (supports ratios of 2:1 to 3:1) ✓ Code 93 ✓ EAN 8/JAN 8 ✓ EAN 13/JAN 13 ✓ EAN 14/UPC-A ✓ Industrial 2 of 5 ✓ Standard 2 of 5 ✓ Interleaved 2 of 5 (supports ratios of 2:1 to 3:1, Modulus 10 Check Digit) ✓ LOGMARS ✓ MSI ✓ Plessey ✓ POSTNET ✓ UPC-E ✓ UPC/EAN Extensions 	
Bar Codes Available (2D)	<ul style="list-style-type: none"> ✓ Codablock ✓ Code 49 ✓ Data Matrix ✓ MaxiCode ✓ MicroPDF417 ✓ PDF 417 ✓ QRcode 	
Rotation Angles	0°, 90°, 180°, and 270°	

Physical/Environmental/Electrical Specifications

Physical Size (L x W x H)		9.8" x 7.9" x 6.75"	249 mm x 200 mm x 171 mm
Weight	Printer	4 lbs.	1.81 kg
	Shipping	7.5 lbs.	3.40 kg
Temperature Range	Operation	40° to 105° F	5° to 41° C
	Storage	-40° to 140° F	-40° to 60° C
Relative Humidity	Operation	10% to 90% (non-condensing)	
	Storage	5% to 95% (non-condensing)	
Electrical		External 90-264 VAC, 47-63 Hz universal power supply. Regional line cords are available.	

Agency Approvals

- n UL 544 Medical Equipment Standard Part 42.5
- n CSA 22.2 No. 950-95 Canadian Safety Standard
- n IEC 950/EN 60950 International Safety Standard
- n FCC Class B
- n UL 1950 Domestic Safety Standard, 3rd Ed.
- n Canadian DOC Class A
- n EN50082-1:1997 International Immunity Standard
- n EN55022 Class B European Electromagnetic Radiation Standard
- n EN61000-3-2, 3 Powerline Disturbance
- n AS/NZS 3548 Australia EMC
- n CE Compliant
- n EMC Taiwan
- n CB Scheme Documents

Options

- n Cutter
- n Black mark (reflective) sensor
- n Real time clock with 8MB FLASH memory
- n External ZebraNet[®] (10Base-T)
- n External ZebraNet[®] PrintServer II[™] (10Base-T)

For details, call your authorized reseller.

Serial (RS-232) Connector Technical Information

Pin No.	Description
1	Not used
2	RXD (receive data) input to the printer
3	TXD (transmit data) output from the printer
4	DTR (data terminal ready) output from the printer -- controls when the host may send data
5	Chassis ground
6	DSR (data set ready) input to the printer
7	RTS (request to send) output from the printer -- always in the ACTIVE condition when the printer is turned on
8	Not used
9	5 V @ 0.75 A fused



NOTES: *The maximum current available through the serial and/or parallel port is not to exceed a total of 0.75 Amps.*

When XON/XOFF handshaking is selected, data flow is controlled by the ASCII control codes DC1 (XON) and DC3 (XOFF). The DTR control lead will have no effect.

Interconnecting to DTE Devices

The printer is configured as data terminal equipment (DTE). To connect the printer to other DTE devices (such as the serial port of a personal computer), use an RS-232 null modem (crossover) cable. [Figure 38](#) shows the required cable connections.

Interconnecting to DCE Devices

When the printer is connected via its RS-232 interface to data communication equipment (DCE) such as a modem, a STANDARD RS-232 (straight-through) interface cable must be used. [Figure 39](#) shows the connections required for this cable.

Connecting the Printer to a DTE Device

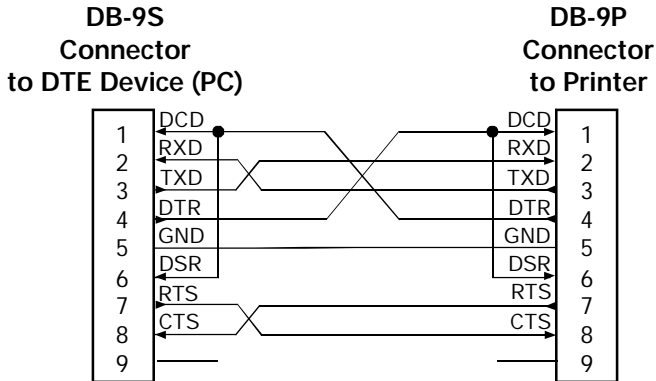
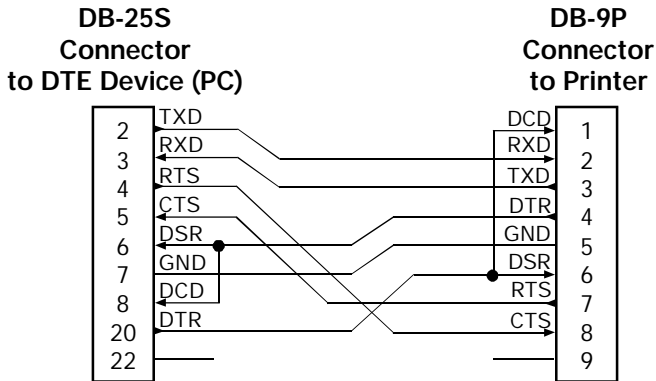
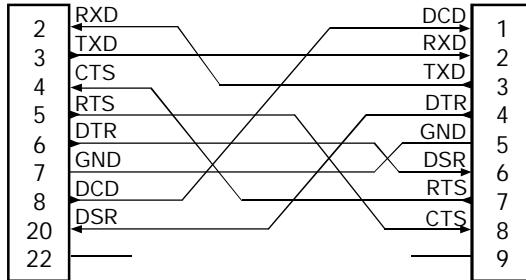

Figure 38

Connecting the Printer to a DCE Device

DB-25S Connector to DCE Device **DB-9P Connector to Printer**



DB-9S Connector to DCE Device **DB-9P Connector to Printer**

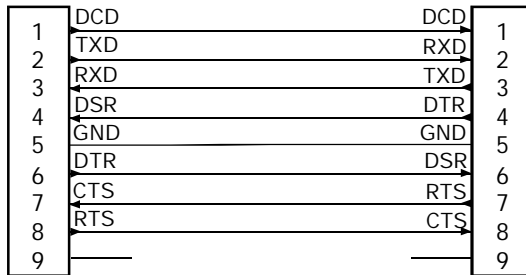

Figure 39

Parallel Interface Technical Information

Pin No.	Description
1	nStrobe/HostClk
2-9	Data Bits 1-8
10	nACK/PtrClk
11	Busy/PtrBusy
12	PError/ACKDataReq
13	Select/Xflag
14	nAutoFd/HostBusy
15	Not Used
16 & 17	Ground
18	+5V @ 0.75A Fused
19-30	Ground
31	nInit
32	nFault/nDataAvail
33 & 34	Not Used
35	+5V through a 1.8 K Ω Resistor
36	nSelectIn/1284 active



NOTE: *The maximum current available through the serial and/or parallel port is not to exceed a total of 0.75 Amps.*

Index

A

Adjustments	
Print darkness	30
Print speed	30
Print width	30
Agency approvals	48
Auto calibration	25
Autobaud	29

C

Calibration	
Auto	25
Manual	34

Cleaning

Cutter	39
Exterior	39
Interior	39
Peel bar	39
Platen roller	39
Printhead	39
Tear bar	39

Communications parameters, setting	29, 37
---	--------

Communications diagnostics	36
--------------------------------------	----

Configuration label	35
-------------------------------	----

Cutter mode	16
-----------------------	----

D

Damage, shipping	2
Darkness, adjusting	30
DCE devices, interconnecting	49
Defaulting the printer	37
DTE devices, interconnecting	49

F

Factory defaults, resetting	36
Fanfold media	20
Feed button	26
Feed button modes	37

I

Inspection	2
----------------------	---

L

Loading the media	
Cutter mode	16
Fanfold	20
Peel-off mode	10
Tear-off mode	5
Loading the ribbon	22
Lubrication	39

M

Maintenance parts	41
Manual calibration	34
Media loading	
Cutter mode	16
Fanfold	20
Peel-off mode	10
Tear-off mode	5

O

Operator controls	26
Options	48

P

Parallel connector pinouts	52
Parts list	41
Peel-off mode	10
Pinouts	
Parallel	52
Serial	49
Power switch	26
Print darkness, adjusting	30, 37
Print speed, adjusting	30
Print width, adjusting	30, 37
Printhead, replacing	44

R

Removing the ribbon	24
Repair parts	41
Replacing the printhead	44
Reporting damage, shipping	2
Ribbon	
Loading	22
Removing	24

S

Serial connector pinouts	49
Set communications (^SC)	29
Specifications	
Font/bar code	47
Label/tag	46
Physical/environmental/ electrical	47
Printing	45
Ribbon	45
Status LED	26, 31

T

Tear-off mode	5
Troubleshooting	31
Troubleshooting tests	35

U

Unpacking	2
---------------------	---

Z

ZPL II	30
ZPL II Programming Guide	1, 30



Zebra Technologies Corporation

333 Corporate Woods Parkway
Vernon Hills, Illinois 60061.3109 U.S.A.
Telephone +1 847.634.6700
Facsimile +1 847.913.8766

Zebra Technologies Europe Limited

Zebra House
The Valley Centre, Gordon Road
High Wycombe
Buckinghamshire HP13 6EQ, UK
Telephone +44 (0)1494 472872
Facsimile +44 (0)1494 450103