



Zebra® QL Plus™ Series
Mobile Printer
User Guide



Contents

Proprietary Statements	4
Document Conventions	6
Cautions, Important, and Note	6
Introduction to the QL Plus™ Series	7
Unpacking and Inspection	7
Reporting Damage	7
QL 220 Plus Overview	8
QL 320 Plus Overview	9
QL 420 Plus Overview	10
Getting Ready to Print	11
Battery.....	11
Installing the Battery	11
QL 220 Plus.....	11
QL 420 Plus.....	11
QL 320 Plus.....	11
Charging the Battery with the LI72 Charger.....	12
Battery Safety	17
Charger Safety.....	17
Loading the Media.....	18
Installing the Media	18
QL 420 Plus and QL 220 Plus Printers	18
QL 320 Plus Printers	19
All models.....	20
QL 420 Plus Printers Only	21
Operator Controls	23
Keypad Control Panel.....	23
LCD Control Panel	25
Programmable LCD Settings	26
Verify the Printer Is Working.....	28
Printing a Configuration Label	28
Connecting the Printer	28
Cable Communication.....	29
IR Communications	32
Wireless Communications with Bluetooth™	33
Bluetooth Networking Overview	33
WLAN Overview.....	34
Setting Up the Software	34
Radio Regulatory Information	36
Zebra Bluetooth Radio QL+ZBR3.....	36
WLAN Module Using 802.11b CF Radio (North America)	37
WLAN Module Using 802.11b CF Radio (Asia & EU Countries)	38
Zebra 802.11b WLAN Radio Module	40
WLAN Module Using 802.11g Radio	42
Compact Flash (802.11b) and Bluetooth Co-located Radio Modules	44
Using the Accessories	46
Belt Clip.....	46
Kickstand	47
Desk Stand.....	48
Carrying Strap	50

Preventive Maintenance	51
Extending Battery Life	51
General Cleaning Instructions	52
QL 220 Plus Cleaning	52
QL 320 Plus Cleaning	54
QL 420 Plus Cleaning	56
Troubleshooting.....	58
Keypad Control Panel.....	58
LCD Control Panel Indicators	59
Troubleshooting Topics	60
Troubleshooting Tests	62
Printing a Configuration Label	62
Communications Diagnostics	62
Contacting Technical Support.....	63
Specifications.....	67
Printing Specifications	67
Memory and Communications Specifications.....	67
Label Specifications	68
Font and Bar Code Specifications	69
Communications Ports.....	70
Physical, Environmental and Electrical Specifications	71
QL Plus Series Accessories	75
Appendix A Interface Cables.....	76
RS232 Cables.....	76
USB Cable.....	76
More Interface Cables	77
Appendix B Media Supplies.....	78
Appendix C Maintenance Supplies	78
Appendix D Product Support.....	79
Appendix E	81
Battery Disposal	81
Product Disposal	81
Appendix F Using zebra.com	82
Index.....	84
Patent Numbers	86

Proprietary Statements

This manual contains proprietary information of Zebra Technologies Corporation. It is intended solely for the information and use of parties operating and maintaining the equipment described herein. Such proprietary information may not be used, reproduced, or disclosed to any other parties for any other purpose without the expressed written permission of Zebra Technologies Corporation.

Product Improvements

Since continuous product improvement is a policy of Zebra Technologies Corporation, all specifications and signs are subject to change without notice.

FCC Compliance Statement

NOTE: This equipment has been tested and found to comply with the limits of a Class B digital device, pursuant to Part 15 of the FCC Rules. These limits are designed to provide reasonable protection against harmful interference in a residential installation. This equipment generates, uses and can radiate radio frequency energy and, if not installed and used in accordance with the instructions, may cause harmful interference to radio communications. However, there is no guarantee that interference will not occur in a particular installation. If this equipment does cause harmful interference to radio or television reception, which can be determined by turning the equipment off and on, the user is encouraged to try to correct the interference by one or more of the following measures:

- Reorient or relocate the receiving antenna.
- Increase the separation between the equipment and receiver.
- Connect the equipment into an outlet or circuit different from that to which the receiver is connected.
- Consult the dealer or an experienced radio/TV technician for help.

WARNING: Exposure to Radio Frequency radiation. To conform to FCC RF exposure requirements this device shall be used in accordance with the operating conditions and instructions listed in this manual. Note that there are several radio options available with this printer. Additional regulatory information is contained in later sections devoted to each radio individually.

NOTE: This unit was tested with shielded cables on the peripheral devices. Shielded cables must be used with the unit to insure compliance.

Changes or modifications to this unit not expressly approved by Zebra Technologies Corporation could void the user's authority to operate this equipment.

Canadian Compliance Statement

This Class B digital apparatus complies with Canadian ICES-003.

Cet appareil numérique de la classe B est conforme à la norme NMB-003 du Canada.

"IC:" before the equipment certification number signifies that the Industry Canada technical specifications were met. It does not guarantee that the certified product will operate to the user's satisfaction.

Agency Approvals and Regulatory Information

- Design certified by CSA
- Canadian STD RSS-210
- EN60950: 2000 Safety Standard
- C-Tick (Australia)
- FCC part 15
- EN55024:1998 European Immunity Standard
- NOM/NYCE (Mexico)
- EN55022:1998 Class B European Electromagnetic Radiation Standard

Liability Disclaimer

Inasmuch as every effort has been made to supply accurate information in this manual, Zebra Technologies Corporation is not liable for any erroneous information or omissions. Zebra Technologies Corporation reserves the right to correct any such errors and disclaims liability resulting therefrom.

No Liability for Consequential Damage

In no event shall Zebra Technologies Corporation or anyone else involved in the creation, production, or delivery of the accompanying product (including hardware and software) be liable for any damages whatsoever (including, without limitation, damages for loss of business profits, business interruption, loss of business information, or other pecuniary loss) arising out of the use of or the results of use of or inability to use such product, even if Zebra Technologies Corporation has been advised of the possibility of such damages. Because some states do not allow the exclusion of liability for consequential or incidental damages, the above limitation may not apply to you.

Copyrights

The copyrights in this manual and the label print engine described therein are owned by Zebra Technologies Corporation. Unauthorized reproduction of this manual or the software in the label print engine may result in imprisonment of up to one year and fines of up to \$10,000 (17 U.S.C.506). Copyright violators may be subject to civil liability.

This product may contain ZPL[®], ZPL II[®], and ZebraLink[™] programs; Element Energy Equalizer[®] Circuit; E3[®]; and AGFA fonts. Software © ZIH Corp. All rights reserved worldwide. ZebraLink and all product names and numbers are trademarks, and Zebra, the Zebra logo, ZPL, ZPL II, Element Energy Equalizer Circuit, and E3 Circuit are registered trademarks of ZIH Corp. All rights reserved worldwide.

Monotype[®], Intellifont[®] and UFST[®] are trademarks of Monotype Imaging, Inc. registered in the United States Patent and Trademark Office and may be registered in certain jurisdictions.

Andy[™], CG Palacio[™], CG Century Schoolbook[™], CG Triumvirate[™], CG Times[™], Monotype Kai[™], Monotype Mincho[™] and Monotype Sung[™] are trademarks of Monotype Imaging, Inc. and may be registered in some jurisdictions.

HY Gothic Hangul[™] is a trademark of Hanyang Systems, Inc.

Angsana[™] is a trademark of Unity Progress Company (UPC) Limited.

Andale[®], Arial[®], Book Antiqua[®], Corsiva[®], Gill Sans[®], Sorts[®] and Times New Roman[®] are trademarks of The Monotype Corporation registered in the United States Patent and Trademark Office and may be registered in certain jurisdictions.

Century Gothic[™], Bookman Old Style[™] and Century Schoolbook[™] are trademarks of The Monotype Corporation and may be registered in certain jurisdictions.

HGPGothicB is a trademark of the Ricoh company, Ltd. and may be registered in some jurisdictions.

Univers[™] is a trademark of Heidelberger Druckmaschinen AG, which may be registered in certain jurisdictions, exclusively licensed through Linotype Library GmbH, a wholly owned subsidiary of Heidelberger Druckmaschinen AG.

Futura[®] is a trademark of Bauer Types SA registered in the United States Patent and Trademark Office and may be registered in some jurisdictions.

TrueType[®] is a trademark of Apple Computer, Inc. registered in the United States Patent and Trademark Office and may be registered in certain jurisdictions.

All other product names are the property of their respective owners.

All other brand names, product names, or trademarks belong to their respective holders.

©2007 ZIH Corp.

Document Conventions

The following conventions are used throughout this document to convey certain information:

Cautions, Important, and Note



Caution • Warns you of the potential for electrostatic discharge.



Caution • Warns you of a potential electric shock situation.



Caution • Warns you of a situation where excessive heat could cause a burn



Caution • Advises you that failure to take or avoid a specific action could result in physical harm to you.

Caution • Advises you that failure to take or avoid a specific action could result in physical harm to the hardware.



Important • Advises you of information that is essential to complete a task.



Note • Indicates neutral or positive information that emphasizes or supplements important points of the main text.

Introduction to the QL Plus™ Series

Thank you for choosing one of our Zebra® QL Plus series Mobile Printers. These rugged printers are sure to become productive and efficient additions to your workplace thanks to their innovative design. Because they are made by Zebra Technologies, you're assured of world-class support for all of your bar code printers, software, and supplies.

- This user's guide gives you the information you will need to operate QL Plus series printers.
- QL Plus printers use the CPCL programming language. To create and print labels using the CPCL language, refer to the Mobile Printer Programming Guide (available at www.zebra.com/manuals) and our Label Vista™ label creation program (available at www.zebra.com/software), which are both available on the Zebra Web site.
- QL Plus™ series printers also have EPL and ZPL II programming language emulation as a standard feature.

Manuals for the ZPL II or EPL2 label design programming languages are also available on our Web site .

Unpacking and Inspection

Inspect the printer for possible shipping damage:

- Check all exterior surfaces for damage.
- Open the media cover (refer to "Loading the Media" in the Getting Ready to Print section) and inspect the media compartment for damage.

In case shipping is required, save the carton and all packing material.

Reporting Damage

If you discover shipping damage:

- Immediately notify and file a damage report with the shipping company. Zebra Technologies Corporation is not responsible for any damage incurred during shipment of the printer and will not cover the repair of this damage under its warranty policy.
- Keep the carton and all packing material for inspection.
- Notify your authorized Zebra re-seller.

QL 220 Plus Overview

Figure 1: QL 220 Plus

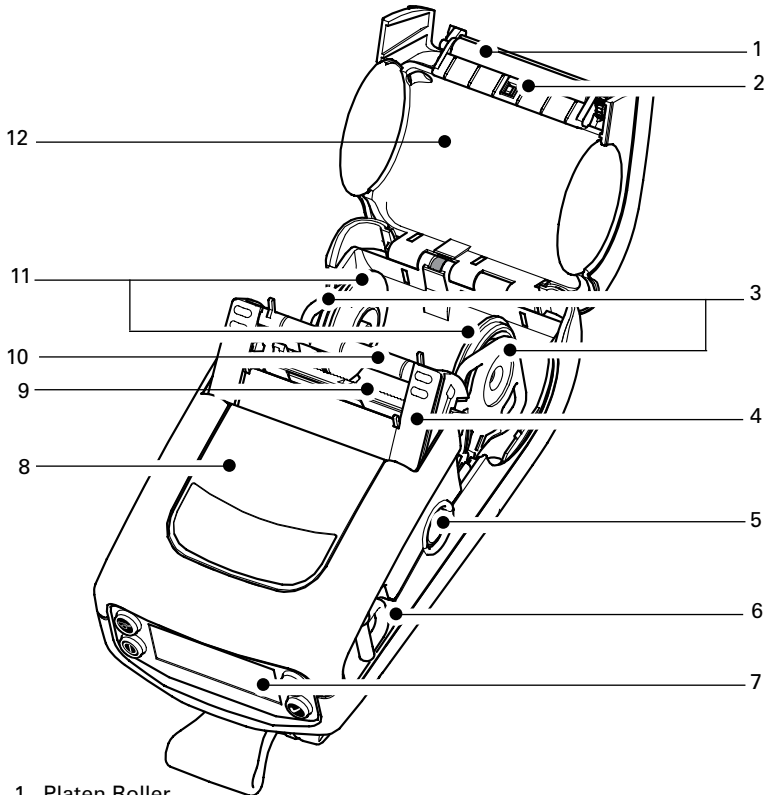

- 1 Platen Roller
- 2 Bar Sensor
- 3 Media Support
- 4 Latch
- 5 Latch Release Button
- 6 "D" Ring
- 7 Control Panel
- 8 QuickLink™ Module
- 9 Print Head
- 10 "E-Z Peel" Label Peeler
- 11 Media Support Disks
- 12 Media Cover

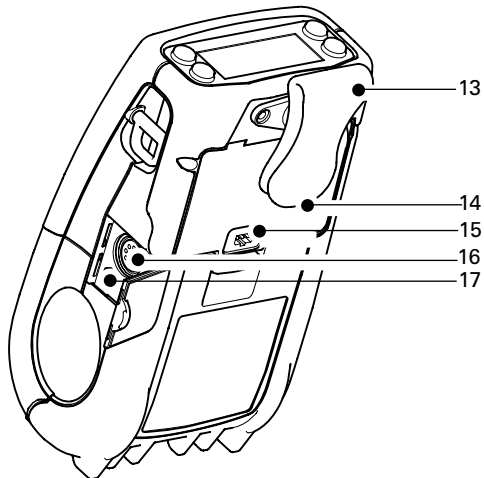

QL 320 Plus Overview

Figure 1B: QL 320 Plus

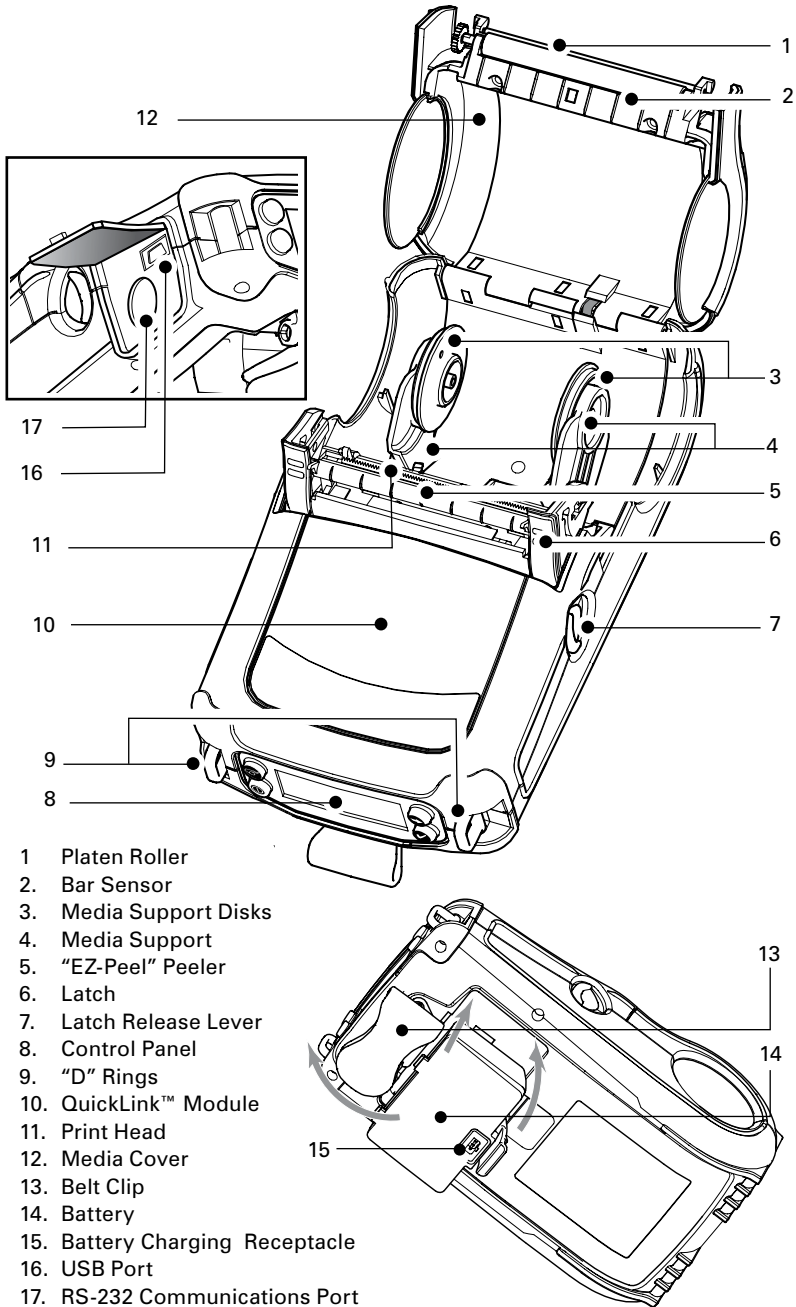

QL 420 Plus Overview

Figure 1C: QL 420 Plus

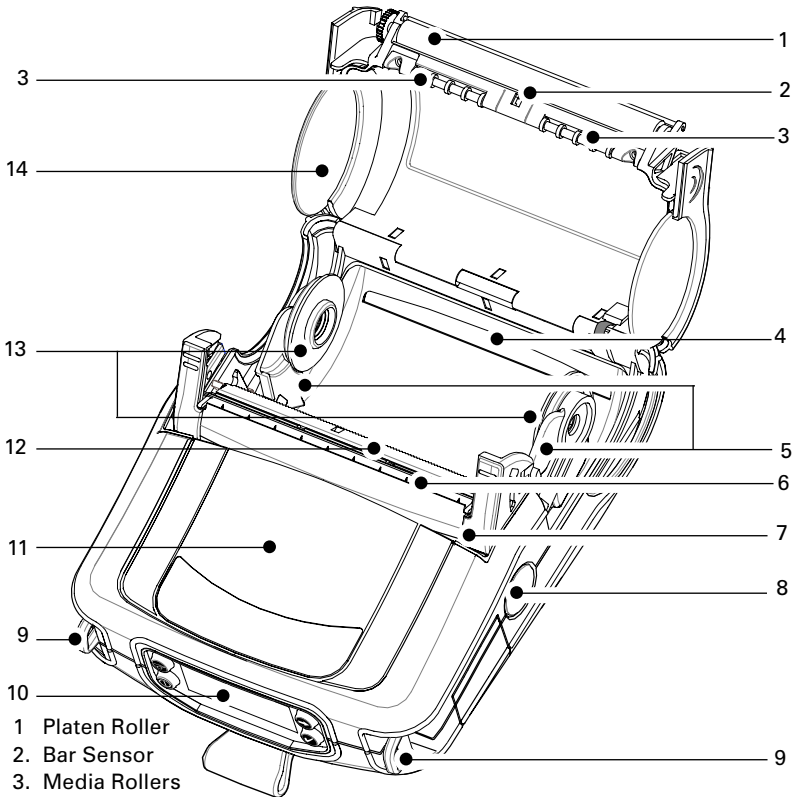

- 1 Platen Roller
- 2 Bar Sensor
- 3 Media Rollers
- 4 Rear Media Slot
- 5 Media Support
- 6 "EZ-Peel" Peeler
- 7 Latch
- 8 Latch Release Button
- 9 "D" Rings
- 10 Control Panel
- 11 QuickLink™ Module
- 12 Print Head
- 13 Media Support Disks
- 14 Media Cover
- 15 RS-232 Communications Port
- 16 USB Port
- 17 Belt Clip
- 18 Battery
- 19 Battery Charging Receptacle

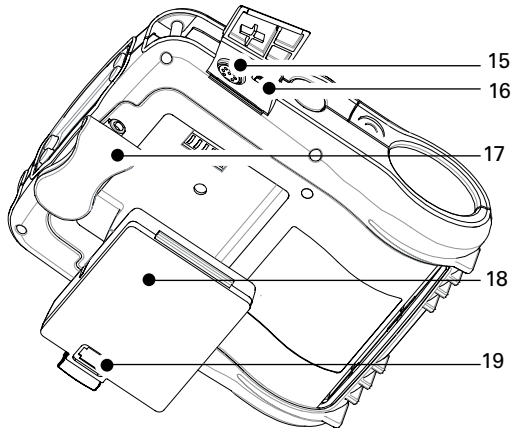

Getting Ready to Print

Battery

Installing the Battery



Important • Batteries are shipped partially charged. Remove protective shrink-wrap and labels from new battery packs prior to use.

1. Rotate the belt clip to allow access to the battery compartment.
2. Insert the battery into the printer as shown in Figure 2.
3. Rock the battery into the printer as shown until it locks in place.

When the battery is first installed, the control panel indicators may briefly turn on and then go off which indicates the battery is not fully charged (see “Charging the Battery” below and “Operator Controls”).

You must charge the batteries fully before using them for the first time. To ensure maximum battery capacity, new batteries should go through two or three complete charge/discharge cycles when first put into service.

Figure 2: Installing the Battery

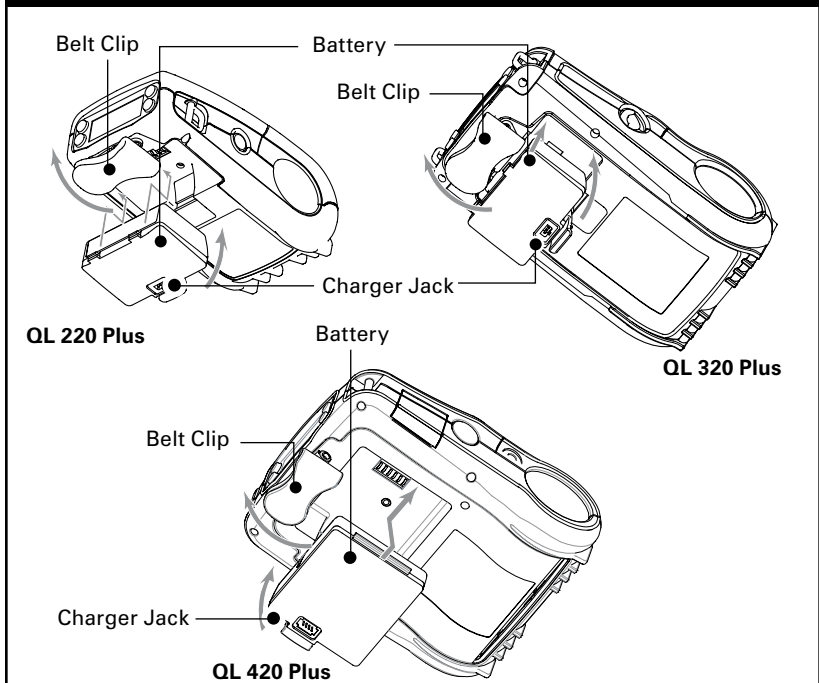

Charging the Battery with the LI72 Charger

Figure 3: LI72 Single Charger

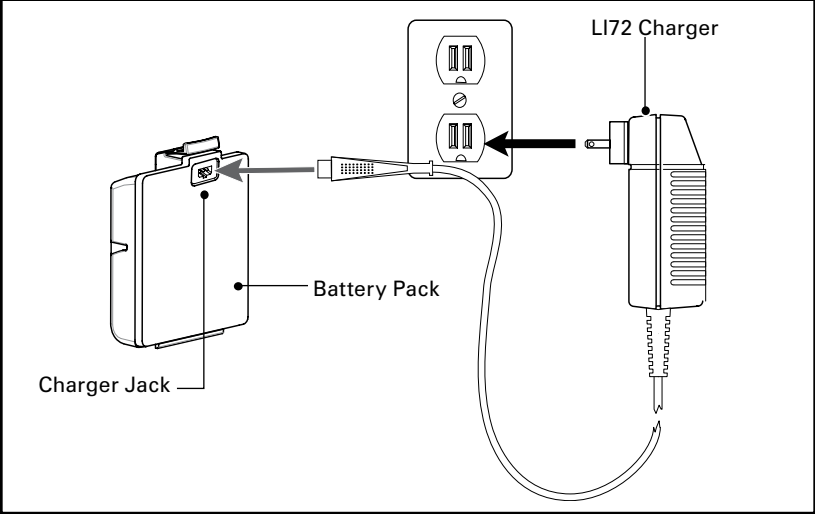
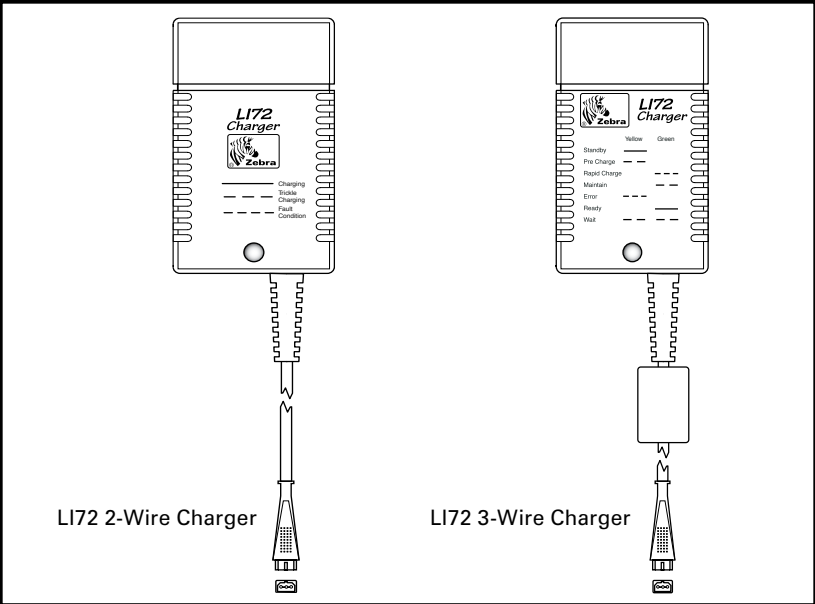

Figure 4: LI72 Single Charger Types



The LI72 is a wall mounted fast charger with universal 110 to 230, 50-60 Hz. VAC input. Multiple A.C. plug configurations comply with most international standards. This charger is intended for use with Lithium Ion (Li-ion) batteries. QL series printers only utilize Li-ion batteries.

The LI72 is supplied in two variations: a two wire version and a three-wire version. The three-wire version offers more intelligent charging features and is used with more-recently produced printers..

Both of the LI72 models will charge a battery pack as fast as its charge level will allow, and then switch over to a maintenance charge to keep the charge at its maximum.

Charging Battery Packs with the LI72 Two-Wire Version

Plug the LI72 into the appropriate A.C. wall receptacle, and then insert the charge cable into the battery pack charger jack.

The charge indicator LED will indicate the status of the charger as follows:

Indicator	Charger Function	Charger Status
Steady	Charging.	Battery Pack is undergoing a fast charge
Slow Flashing (1 HZ)	Maintain	Battery is ready for use
Rapid Flashing (4 Hz)	Error	The battery may have an internal short, or its charge monitoring circuitry may be malfunctioning. The battery pack should not be used any further.



Do not charge batteries with the two-wire LI72 model while printing. Attempting to print while charging can result in improperly charged batteries.

Caution • Do not leave the two-wire charger plugged into a battery pack for a prolonged period of time when it is installed in the printer and has reached the maintenance charge state. Charging a battery when installed in a printer for a prolonged period of time could cause damage to the printer.

Charging Battery Packs with the LI72 Three-Wire Version

Plug the LI72 into the appropriate A.C. wall receptacle, and then insert the charge cable into the battery pack charger jack.

The yellow/green charge indicator LED will indicate the status of the charger as per the following table.



Do not charge batteries with the three-wire LI72 model while printing. Attempting to print while charging can result in improperly charged batteries.

Indicator	Charger Function	Charger Status
Steady yellow indicator	Standby	AC power on; no battery being charged
Slow (1 Hz) flashing yellow indicator	Pre-Charge	Charger is applying trickle charge current (5% of maximum) to bring a cold battery temperature up to 0°C before starting a full charge cycle
Fast (4 Hz) flashing green indicator	Rapid Charge	Charger is applying the maximum charge rate to the battery
Slow (1 Hz) flashing green indicator	Maintain	Charger is in trickle charge mode(10% of nominal charge value).
Fast (4 Hz) flashing yellow indicator	Error	The battery may have an internal short, or its charge monitoring circuitry may be malfunctioning. The battery pack should not be used any further.
Steady green indicator	Ready	No charge is being applied to the battery
Slow (1 Hz) flashing alternate yellow and green indicator	Wait	Battery temperature is too hot. Charging will not begin until battery temperature reaches 45°C.



Charging will cease three (3) hours after the charger has entered the "Maintain" mode.

Model UCLI72-4 Quad Charger

Figure 5: Quad Charger

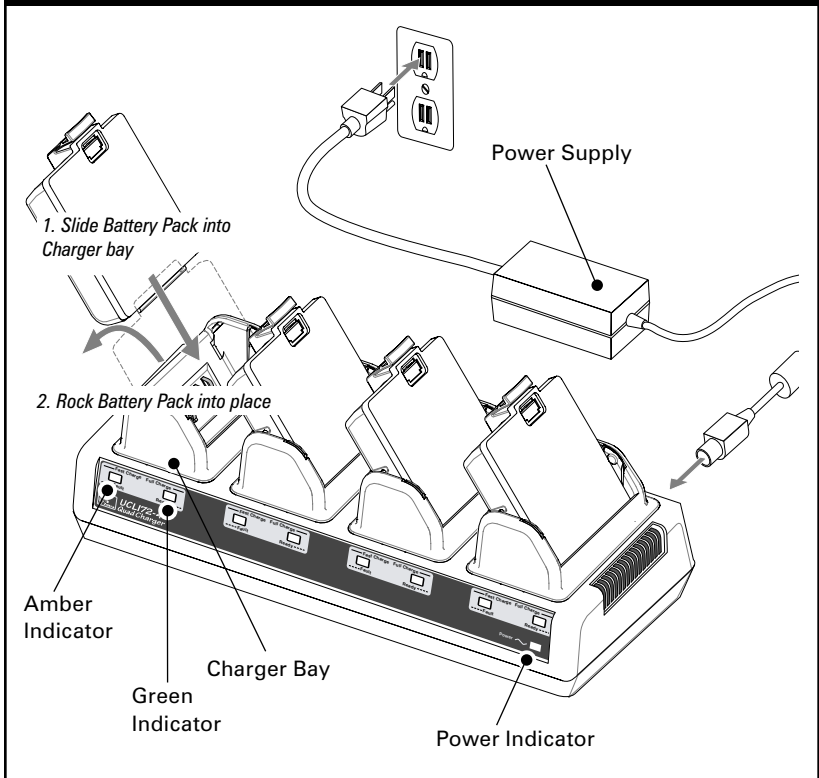

The UCLI72-4 Quad Charger is designed to charge up to four QL series battery packs simultaneously. Batteries must be removed from the printer to be charged in the Quad Charger.

1. Ensure that the charger has been installed properly per the Quad Charger instruction manual. Ensure that the power indicator on the front panel is on.
2. Remove any protective shrink-wrap and labels from all battery packs prior to use. Plug a battery pack into any one of the four charging bays as shown in Figure 5, noting the orientation of the battery pack. Slide the battery pack into the charging bay until it stops and then rock the battery pack back until it snaps into place. The amber indicator di-

continued

rectly under the battery being charged will turn on if the battery is properly inserted.

The indicators under the battery will allow you to monitor the charging process per the table below:

Amber	Green	Battery Status
On	Off	Charging
On	Flashing	80% charged (O.K. to use)
Off	On	Completely Charged
Flashing	Off	Fault



Important • A fault condition is caused by a problem with the battery. The charger may indicate a fault because the battery is too hot or cold to charge reliably. Try to charge the battery again when it returns to the room's ambient temperature. If the amber indicator starts flashing on the second attempt, the battery should be discarded. Always dispose of batteries in a proper manner as described in Appendix E.

Quad Charger Cycle Times :

Battery Status	QL 220Plus & QL 320 Plus	QL 420 Plus
Battery 80% Charged	1.25 Hrs.	2.5 Hrs.
Battery Fully Charged	2.5 Hrs.	5 Hrs.



Note • These times are for completely discharged batteries.

Battery packs which are only partially discharged will take less time to reach their charged state. Batteries which have reached 80% of their charge capacity may be used, however, it is recommended that you allow the batteries to reach a full charge to maintain maximum battery life.



The UCLI72-4 Quad Charger has a safety feature which stops charging a battery after six hours regardless of its charge state.

Battery Safety



Caution • Avoid accidental short circuiting of any battery. Allowing battery terminals to contact conductive material will create a short circuit which could cause burns and other injuries or could start a fire.



Important • Always refer to the Important Safety Information data sheet shipped with each printer and the Technical Bulletin shipped with each battery pack. These documents detail procedures to ensure maximum reliability and safety while using this printer.



Important • Always dispose of used batteries properly. Refer to Appendix E for more battery recycling information.

Caution • Use of any charger not approved specifically by Zebra for use with its batteries could cause damage to the battery pack or the printer and will void the warranty.

Charger Safety



Do not place any charger in locations where liquids or metallic objects may be dropped into the charging bays.



Use care when installing either the LI72 Single Chargers or the UCLI72-4 Quad Charger so that you do not block the ventilating slots on the top and bottom covers. Ensure that the charger is plugged into a power source which will not accidentally be turned off if you will be charging batteries overnight.

Loading the Media

You can operate QL Plus printers in one of two different modes: Tear-Off or Peel-Off. Tear-Off mode allows you to tear off each label (or a strip of labels) after it is printed. In Peel-Off mode, the backing material is peeled away from the label as it is printed. After you remove this label, the next one is printed.

QL 420 Plus and QL 220 Plus Printers

1. Open the printer: Refer to Figure 6 (QL 420 shown).
 - Press the latch release button on the side of the printer as shown at "1" below. The latch assembly will flip open automatically
 - On the QL 420 Plus only, pull up the latch assembly completely as shown at "2" to unlatch the Media Cover.
 - Rotate the Media Cover back as shown at "3", exposing the media compartment and the adjustable media supports.

Figure 6: Opening the QL 420 Plus & QL 220 Plus

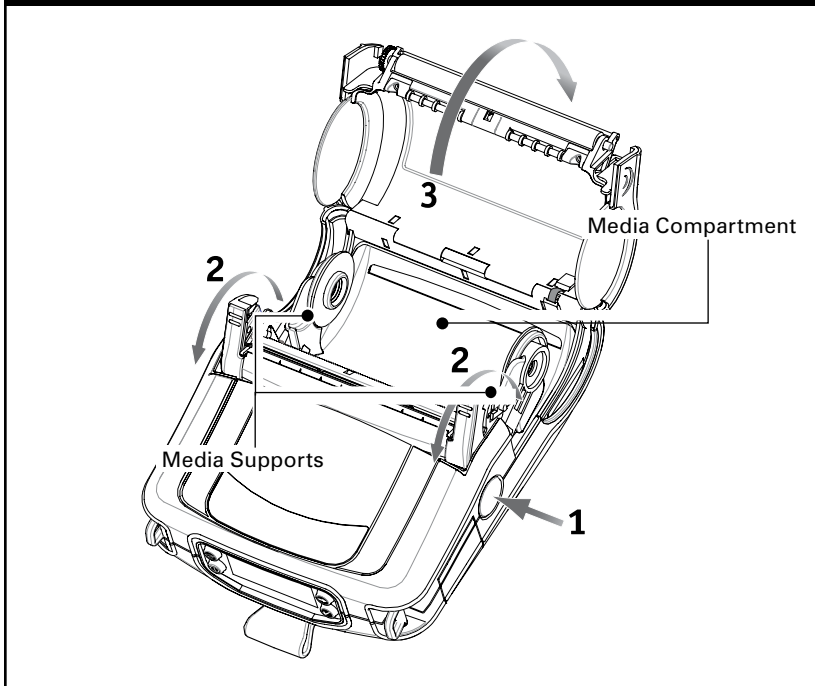

QL 320 Plus Printers

1A. Open the printer: Refer to Figure 6a.

- Rotate the latch release levers on each side of the printer as shown at "1" below. The latch assembly will flip open automatically as shown at "2".
- Rotate the Media Cover back as shown at "3", exposing the media compartment and the adjustable media supports.

Figure 6a: Opening the QL 320 Plus

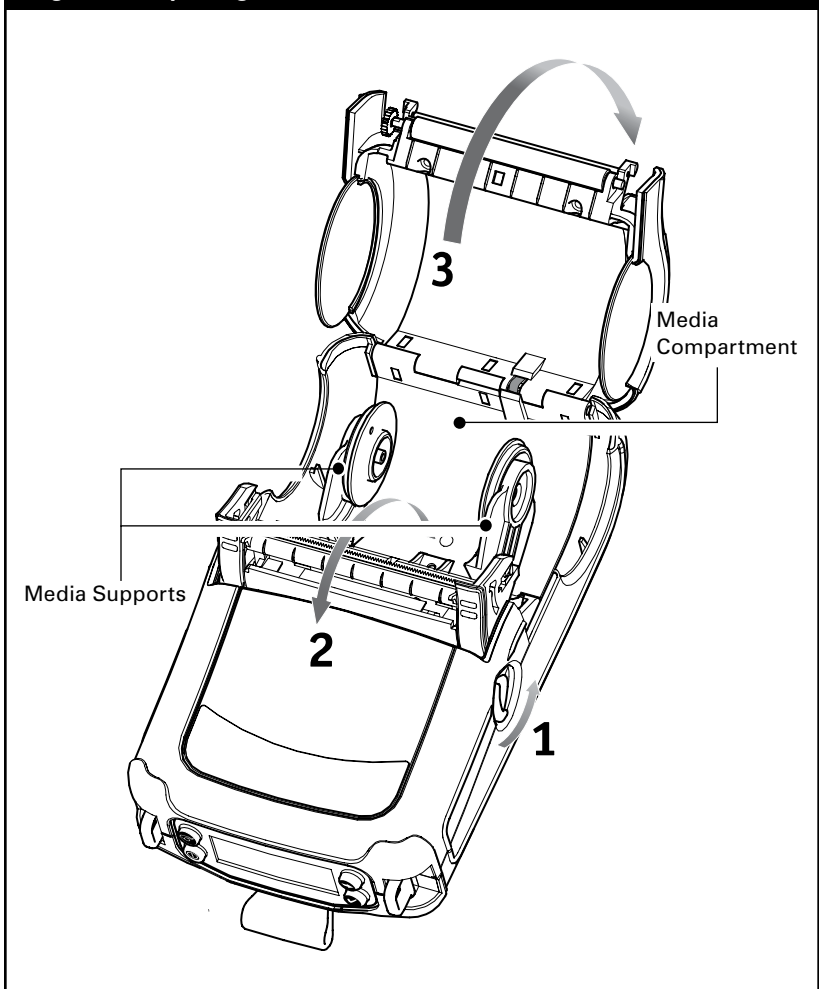

continued

All models

2. Load the media:

Loading media from an internal supply. Refer to Figure 7.

- Grasp the media supports where shown and pull them apart. Insert the roll of media between them, and let the media supports close. Ensure that the media pulls off the core in the direction shown in Figure 6. The supports will adjust themselves to the width of the media, and the media should be able to spin freely on the supports.

Figure 7: Loading Media (All Models)

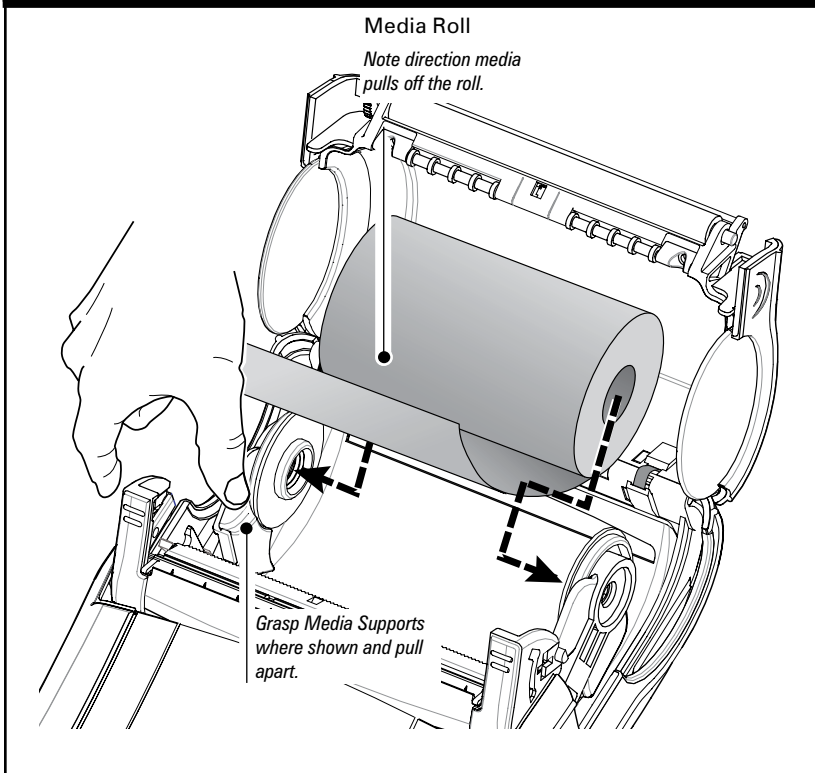

QL 420 Plus Printers Only

2A. Load the media from an external supply:

The QL 420 Plus has a loading slot in the rear of the media compartment which allows you to use standard 4" (101.6 mm) wide fan-fold media from an external supply. Refer to Figure 8. The external supply must be designed such that it does not exert excessive drag as media is fed through the printer, which could result in distorted printing.

Zebra can provide a vehicle mount (p/n DC16620-1) designed specifically for the QL 420 Plus which incorporates an external media supply bin.

- Pull the media supports apart, insert a Media Spacer (Zebra part number BA16625-1) between them, and let the media supports close. Insert the media from the exter-

Figure 8: Loading Media from an External Supply (QL 420 Plus only)

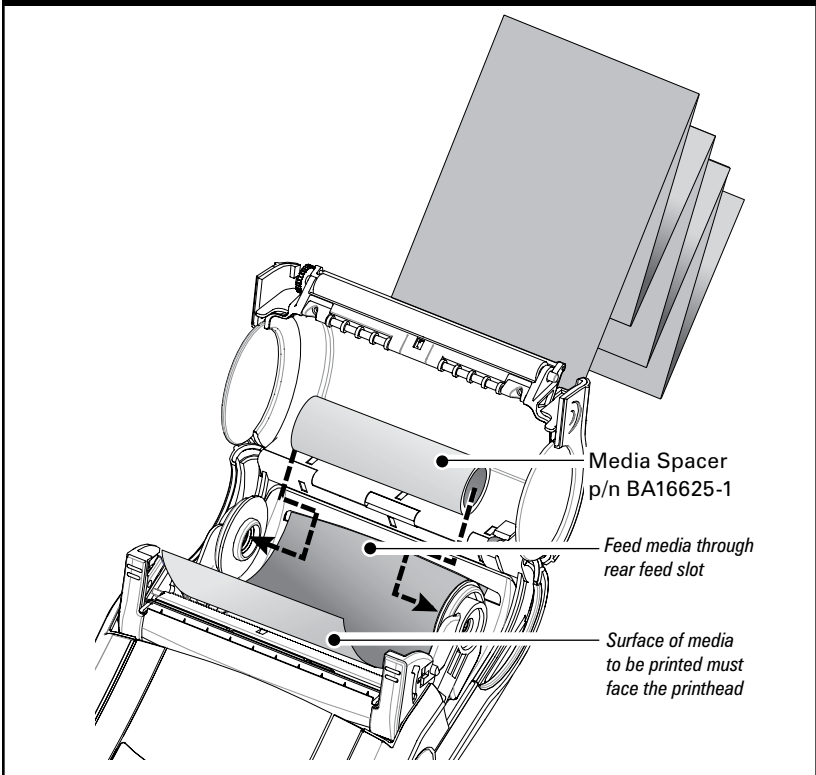

continued

nal supply through the rear feed slot, between the media guides and up through the media compartment as shown. Make sure the side of the media you will be printing on faces the print head.

3. Close the Media Cover: Refer to Figure 9.

- If you plan to use the printer in the tear-off mode, close the media cover as shown at “2”, then rotate the latch assembly as shown until it locks into place, as shown at “4”.
- If you plan to use the printer in the peel-off mode, peel a few labels off of the media and pull it out of the printer as shown at “1”. Close the media cover as shown at “2”. Rotate the “EZ-Peel” peeler bar until it locks into place on the latch, as shown at “3”, then rotate the Latch as shown until it locks into place, as shown at “4”.
- Turn on the printer or press the Feed button if the printer is already on.

The printer will advance the media to the next label, if printing labels. If you are printing on journal media, the printer will advance a short strip of media.

Figure 9: Closing the Media Cover

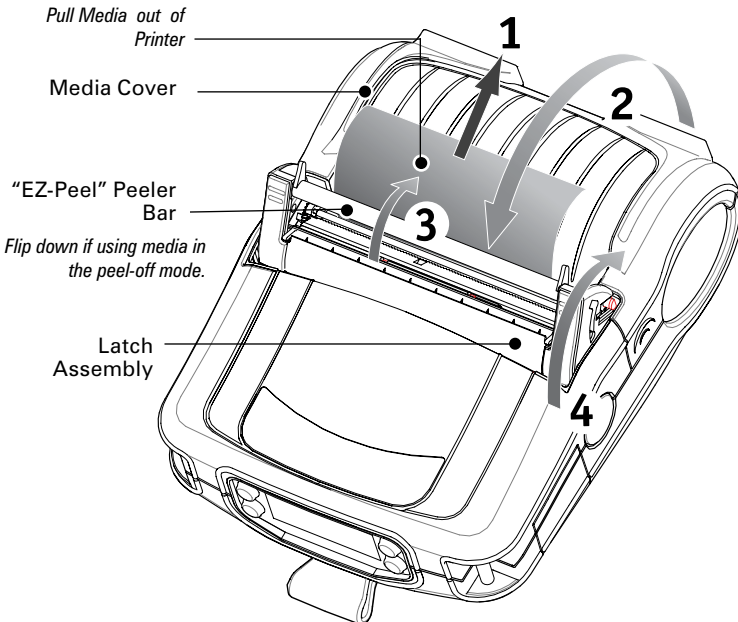

Operator Controls

QL Plus printers are available with one of two possible control panels. The keypad control panel is detailed below and in Figure 10. The optional LCD control panel (Figure 11) allows easy display and selection of many printer functions as detailed on following pages.

Keypad Control Panel

The keypad control panel has three control buttons and two multipurpose indicators.

- The **Power Button** turns the printer on and off.
- The **Feed Button** advances a length of media which is determined by the type of media being used. Label media will be advanced to the next gap or bar sense marker. Journal (plain) media will be advanced a length determined by the printer's software.
- The **Function (FTN) Button** is controlled by a printer's specific application to support such functions as:
 - Print a battery level report.
 - Print the Local Area Network (LAN) status
 - Print a Short Range Radio Frequency (SRRF) status
 - Print a media supply report

The **Green LED** on the left side of the control panel indicates the status of several printer features:

- A slowly blinking sequence indicates the printer's battery needs charging.
- Printers with a wireless QuickLink module installed: a quickly blinking sequence indicates the printer has not established a link to either a Local Area Network or a compatible wireless equipped terminal.
- Printers with a wireless QuickLink module installed: A steadily lit indicator shows that the printer has established a wireless link, either to the LAN or to a compatible terminal.
- A steadily lit green indicator on a printer with no wireless option installed is a power-on indicator.

The **Yellow LED** on the right side of the control panel has two indication conditions.

- A rapidly blinking yellow LED and a chime indicate that no application has been loaded into the printer.

continued

- Printers with a wireless QuickLink module installed: a rapidly blinking LED indicates normal data transmission.
- A steadily lit yellow LED indicates an error condition. This can be caused by one of the following:
 1. The media cover is not completely closed and latched.
 2. The printer is out of media.

Figure 10: Standard Control Panel

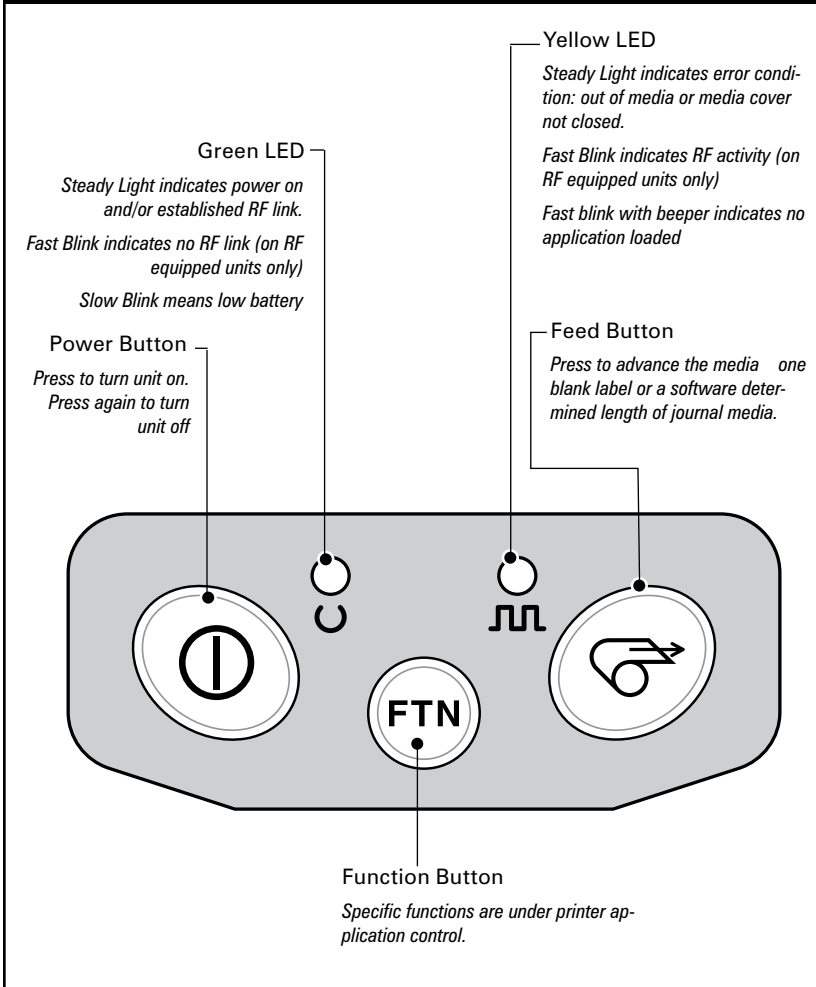

LCD Control Panel



The optional LCD control panel has buttons for the power on/off and media feed functions just as in the standard control panel. It also has two keys which allow navigation and selection of menu options affecting printer functions.

The "Scroll" button allows scrolling through the various options and settings. The "Select" button allows selection of the option or function displayed on the screen.

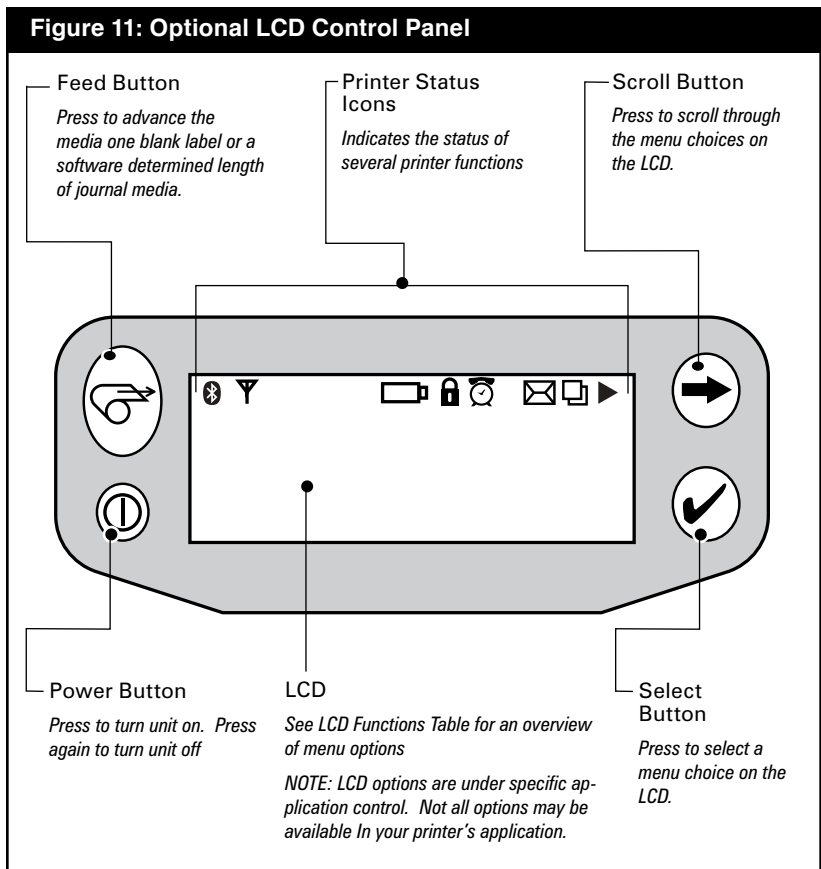
The top of the screen has a row of status icons which indicate the state of various printer functions:



continued

 or  Indicates Bluetooth communications status. A “bulb” icon appears on earlier printers; the “Bluetooth” icon () will appear on the most recent QL Plus series displays. This icon will either be on to indicate a Bluetooth connection, or off. These icons appear only on printers with the Bluetooth wireless option installed.

 Indicates that the printer is connected to a radio network via 802.11b/g protocols. It remains on with a valid connection. If the icon is off, there is no connection to a radio network.



 A flashing icon indicates low battery status. You should suspend printing operations and recharge or replace the Battery Pack as soon as is convenient.

 A flashing icon indicates that the media cover is open or not properly latched.

 Indicates normal printing activity.

 Indicates that data transmission is occurring.

 A flashing icon indicates that the printer does not detect any media. This could indicate an out of media condition, or improperly loaded media.

► A flashing icon, in conjunction with a steadily lit Bluetooth icon ( or ) or the 802.11b/g icon () indicates wireless data transmission. It also indicates cable communications when the printer is connected via the serial (RS232) port.

Programmable LCD Settings

In addition to the status icons, the LCD on the control panel can display other printer settings and functions as text. Applications can be written to allow the user to view and /or modify these settings using the scroll and select keys on the display. Refer to the table on the following page for a partial set of printer features that can be displayed on the LCD.

The LCD backlighting option allows viewing of the screen in a dark environment, or provides better contrast in a very bright environment. Extensive use of the display backlight will decrease the time the printer can run between charges. Refer to the section “Extending Battery Life” for more information.

Extended LCD Functions

Function	Default setting	Scroll & Select Options
Sensor Type	Bar	Bar
		Gap
Baud Rate	19200	9600
		19200
		32400
Data Bits	8	7
		8
WLAN ID*	Factory Set Value	N/A
Label Top	000	Increase (+ 120 dots
		Decrease (-120 dots max.)
Left Position	000	Increase (+ 120 dots max.)
		Decrease (-120 dots max.)
LCD Contrast	0	Increase
		Decrease
No-activity time-out*	60 sec.	60 sec.
		5 min.
		10 min.
		30 min
		Custom
Tear-off Position	00	Increase (+ 120 dots max.
		Decrease (-120 dots max.
Media Type	Label	Label
		Journal
Media Width Sensing†	Off	On
		Off
		Display Width
LCD Backlight	Off	On
		Off
		Momentary On w/ time delay
Factory Reset (Resets all to factory set values)	No	No
		Yes

* Some parameters, such as the WLAN ID number and non-standard no-activity time out values can be set using a PC running Zebra's Label Vista label creation program and a data cable link to the printer.

† Media width sensing is an option. Display for this option may not be visible, or selection options may change, depending on the printer's application.

Verify the Printer Is Working

Before you connect the printer to your computer or portable data terminal, make sure that the printer is in proper working order. You can do this by printing a configuration label using the “two key reset” method. If you can’t get this label to print, refer to “Troubleshooting”.

Printing a Configuration Label

1. Turn the printer off. Load the media compartment with journal media (media with no black bars printed on the back)
2. Press and hold the Feed Button.
3. Press and release the Power button and keep the Feed button pressed. When printing starts, release the Feed button.

The unit will print a line of interlocking “x” characters to ensure all elements of the print head are working, print out the version of software loaded in the printer and then print two reports.

The first report indicates model, ROM version, serial number, baud rate, etc. The second report prints out more detailed information on the printer’s configuration and parameter settings. If no second report appears, there is no application loaded. (See the Troubleshooting Section for sample printouts and a further discussion on how to use the configuration label as a diagnostic tool.)

Connecting the Printer

The printer must establish communications with a host terminal which sends the data to be printed. Communications occur in four basic ways:

- QL Plus series printers can communicate by cable via either RS-232C or USB 2.0 protocols. USB drivers are included in the Zebra Universal Driver which can be downloaded from www.zebra.com/drivers.
- Linking to a host terminal via Infrared (usually by means of the industry standard IrDA protocol)
- By means of a Bluetooth™ short range radio frequency link.
- By means of a wireless LAN (Local Area Network) per 802.11b/g specifications.

Cable Communication

Caution • *The printer should be turned off before connecting or disconnecting a communications cable.*

All QL Plus series printers can communicate by cable; the specific cable supplied with your printer will vary with the host terminal and your model printer.

RS-232C Communications

The 8-pin circular connector on your communications cable plugs into the serial communications port on the side of the printer. QL Plus model printers also have a USB port.

USB Communications

The small connector on the USB cable plugs into the printer. The connectors are keyed to assure correct alignment; do not try to force the cable if it does not plug in. The other end of

Figure 12: Cable Communications

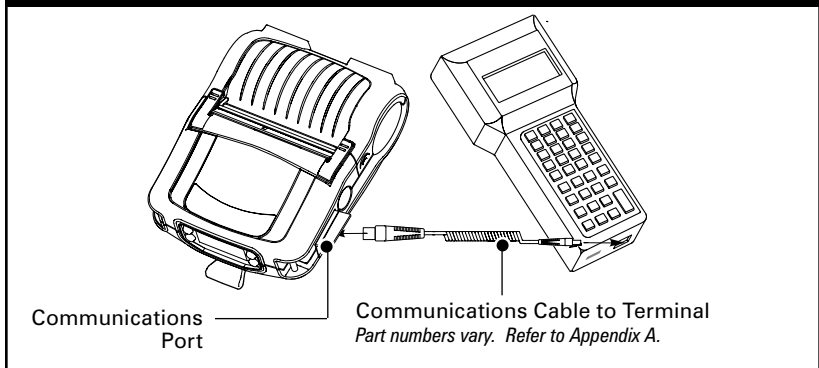
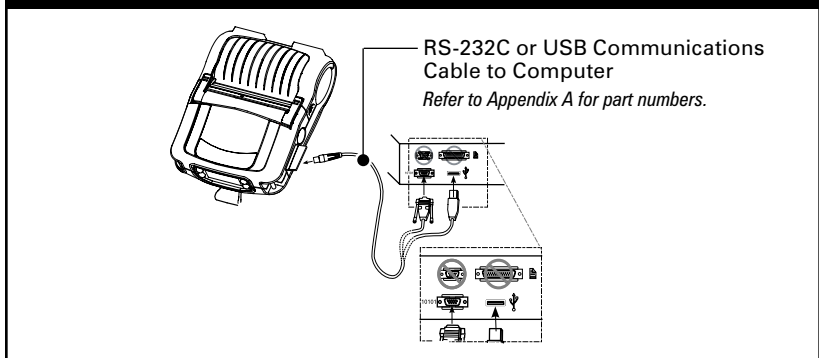

Figure 13: Communications with a P.C.



the cable must be plugged into the host terminal as shown in Figure 12, or to a serial or USB port on a computer (Figure 13.) The QL Plus series is configured with the USB Open HCI interface driver allowing it to communicate with Windows® based devices.

USB drivers are included in the Zebra Universal Driver which can be downloaded from the Zebra Web site. Other terminals or communications devices may require the installation of special drivers to use the USB connection. Consult the factory for further details.

Providing Strain Relief for Communications Cable

If you are connecting a communications cable to the printer permanently, use the strain relief features built into the belt clip retainer to prevent excessive strain on the communications connector. There are two kinds of strain relief features. If you are using the printer with the standard belt clip, bend the cable in a broad loop to relieve stress on the connector and press it into the retaining feature on the belt clip retainer as shown in figure 14.

Figure 14: Communications Strain Relief

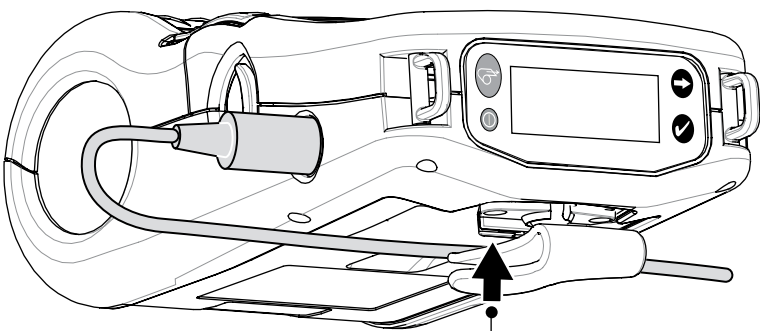

Press communications cable into strain relief feature on Belt Clip

If you have a printer equipped with the Kickstand option, you must first remove the belt clip retainer as shown in Figure 15, retaining the two screws holding the retainer to the lower cover. Arrange the communications cable in a broad loop as detailed above, and capture it in the strain relief feature on the bottom of the belt clip retainer. Then re-secure the belt clip retainer to the bottom cover of the printer.



Refer to the *Using the Accessories* section for more information on the use of the kickstand option

Figure 15: Communications Strain Relief with Kickstand option



The kickstand is not shown in this view for clarity

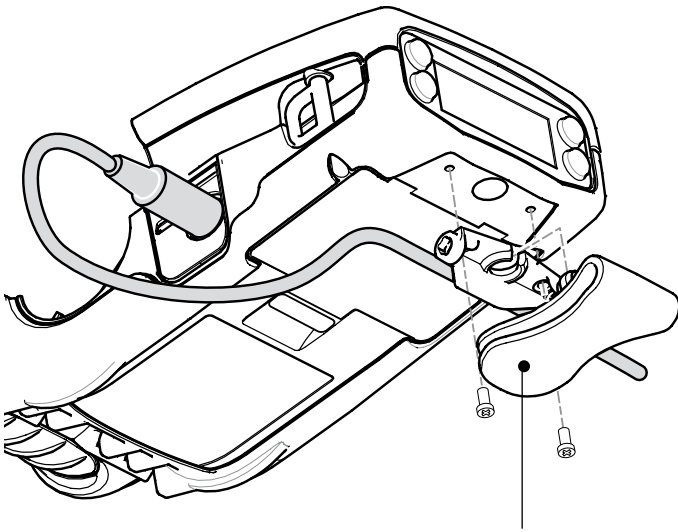

1. Remove Belt Clip Retainer, along with Belt Clip and Kickstand.
2. Press communications cable into strain relief feature on bottom of Belt Clip
3. Reassemble Belt Clip to bottom cover.

IR Communications

Printers equipped for infrared (IR) communications are identified by a small “IR” logo on the unit’s label. Printers with the IR option conform to the IrDA communications protocol.



IR functions are disabled if a communications cable is plugged into the printer.

Ensure that there is a direct line of sight between the printer and the terminal that will be sending data. The IR window on the front of the printer must face the corresponding window on the terminal to properly send and receive signals.

IrDA compliant terminals will automatically initiate communications to the printer. An IrDA terminal will seek out any linkable devices and establish communications between them, even turning the printer on if necessary.

Figure 16: IR Communications

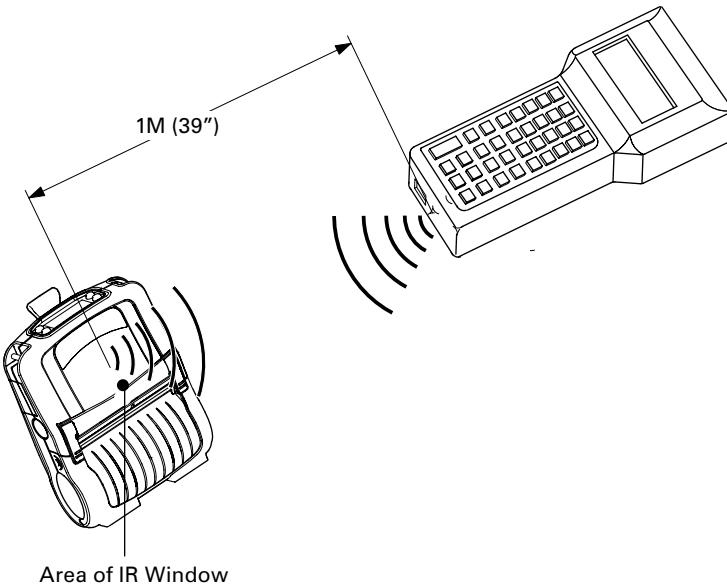

Wireless Communications with Bluetooth™

“Bluetooth” is a worldwide standard for the exchange of data between two devices via radio frequencies. Bluetooth radios are relatively low powered to help prevent interference with other devices running at similar radio frequencies. This limits the range of a Bluetooth device to about 10 meters (32 feet). Both the printer and the device it communicates with must follow the Bluetooth standard. Other than conditions specified elsewhere in this manual, only one of the radio options can be installed in the printer at one time and the antenna used for these transmitters must not be co-located or must not operate in conjunction with any other antenna.

Bluetooth Networking Overview

Each Bluetooth enabled QL Plus printer is identified by a unique Bluetooth Device Address (BDA) loaded into its QuickLink module when manufactured. In order to exchange data, two Bluetooth enabled devices must establish a connection.

Bluetooth software is always running in the background, ready to respond to connection requests. One device (known as the *master* or the *client*) must request a connection with another. The second device (the *slave* or the *server*) then accepts or rejects the connection. A Bluetooth enabled QL Plus printer will normally act as a slave creating a miniature network with the terminal sometimes referred to as a “piconet”.

For the most part, communications using the Bluetooth protocol are initiated and processed without any operator intervention.

QL 220 Plus and 420 Plus printers can be equipped with both a Bluetooth and an 802.11b radio, allowing communications with both Bluetooth enabled devices and a Wireless Local Area Network (WLAN) (see WLAN discussion following).

continued

WLAN Overview

QL Plus printers can be equipped with radios using the industry standard 802.11 protocols. They will have the FCC ID number on the serial number label on the back of the unit.

- QL Plus series Wireless Network Printers with the Zebra 802.11g WLAN radio module can be identified by the text “Wireless Network Printer” and FCC ID: *I28MD-ZLAN11G* on the serial number label on the back of the printer.
- QL 220 and QL 420 Plus printers can be configured with both an 802.11b WLAN radio and a Bluetooth radio running in the same unit. At present only one dual radio configuration is offered, with Bluetooth radio FCC ID “I28MD-BTCT2Y4” and 802.11b Compact flash radio FCC ID number “I28MD-RW4137”. The FCC ID numbers and other regulatory information for both radios are located on the serial number label on the back of the printer.

These printers allow wireless communication as a node within a local area network, (LAN) and its wireless capabilities allow communications from any point within the LAN’s perimeter. Printers equipped with the dual Bluetooth and 802.11b WLAN radio configuration can be linked to both a WLAN and a Bluetooth network. Methods of establishing communications to the printer will vary with each LAN application.

Methods of establishing communications to QL series printers will vary with each LAN application. General information on establishing WLAN communications can be found in either the “CPCL Programmers Manual” or the “Quick Start Guide for Mobile Wireless Printers” both available on-line. More information and LAN configuration utilities are included in Zebra’s Label Vista™ program (version 2.8 and later). Label Vista may be downloaded from the Zebra Web site.

Setting Up the Software

QL Plus printers use Zebra’s CPCL Programming language which was designed for mobile printing applications. CPCL is fully described in the “CPCL Programmers Manual”, available on-line at www.zebra.com/manuals.

You can also use Label Vista™, Zebra’s Windows® based label creation program which uses a graphical interface to create and edit labels in the CPCL language.

Refer to Appendix F for tips on downloading the Label Vista application from Zebra's Web site.

QL series printers with an optional memory upgrade can support an interpreter for ZPL II®, or EPL programming languages. QL Plus series printers also have interpreters for ZPL II® or EPL programming languages included as a standard part of their operating system.

If you plan to use ZPL II or EPL, refer to the appropriate Programming Guides which are also available on-line from Zebra's Web site at www.zebra.com/manuals. If you choose to use a third party label preparation system, follow the installation instructions included in the package.

Radio Regulatory Information

Zebra Bluetooth Radio QL+ZBR3



Caution • Exposure to Radio Frequency Radiation. The radiated output power of this internal Bluetooth radio is far below the FCC radio frequency exposure limits. The internal Bluetooth radio operates within guidelines found in radio frequency safety standards and recommendations. Do not use the printer in an unauthorized manner.



Note • The following section only applies when the QL+ZBR3 (FCC ID: I28MD-BTC2TY4) Bluetooth Radio is installed in a QL Plus series printer. Unless specified elsewhere in this manual, the antenna used for this transmitter must not be co-located or must not operate in conjunction with any other antenna.

European Regulatory Information for this Radio

This device is intended for use in all EU and EFTA member states.

Europe – EU Declaration of Conformity

This device complies with the essential requirements of the R&TTE Directive 1999/5/EC. The following test methods have been applied in order to prove presumption of compliance with the R&TTE Directive 1999/5/EC:

- EN55022:1998
European Immunity Standard
- EN 60950: 2000
Safety of Information Technology Equipment
- EN 300 328-2 V1.4.1 (2003-04)
Technical requirements for spread-spectrum radio equipment
- EN 301 489-1/-17 V1.5.1/1.2.1 (2003-12) -17 v1.2.1 (2002-08)
EMC requirements for spread-spectrum radio equipment.

This device is a 2.4 GHz wireless LAN transceiver, intended for indoor home and office use in all EU and EFTA member states.



Important Notice:

This device is a portable RF printer intended for commercial and industrial use in all EU and EFTA member states.

WLAN Module Using 802.11b CF Radio (North America)

The following section only applies when the CF (Compact Flash) WLAN module (With FCC ID: I28MD-RW4137) is installed in a QL Plus series printer (note that only one of the radio options can be installed in the printer at one time). Other than conditions specified elsewhere in this manual, only one of the radio options can be installed in the printer at one time and the antenna used for these transmitters must not be co-located or must not operate in conjunction with any other antenna.

QL model printers have the FCC ID number label on the front of the module, and QL Plus models have the FCC ID number on a label on the back of the unit.



Caution • Use of a QL Plus series printer with the radio module marked with FCC ID: I28MD-RW4137 meets the FCC requirements for radio frequency (RF) radiation exposure in the standard body worn configuration with no minimum separation. In this configuration, which applies whether the belt clip or shoulder strap is used, the face of the printer from which paper is transported is facing away from the user's body. The standard configuration must always be used when the printer is body worn.

The QL 220 Plus, QL 320 Plus and QL 420 Plus printers with this radio option have been SAR tested. The maximum SAR value measured for each model is listed below:

Model	SAR value W/Kg (1g average)
QL220 Plus	0.0618
QL 320 Plus	0.0500
QL 420 Plus	0.0432

WLAN Module Using 802.11b CF Radio (Asia & EU Countries)

The following section only applies when the CF (Compact Flash) WLAN module (With FCC ID: H9PLA4137) is installed in a QL Plus series printer. Other than conditions specified elsewhere in this manual, only one of the radio options can be installed in the printer at one time and the antenna used for these transmitters must not be co-located or must not operate in conjunction with any other antenna.

QL Plus models have the FCC ID number on a label on the back of the unit.





Caution • Use of a QL Plus series printer with the radio module marked with FCC ID:H9PLA4137 meets the FCC requirements for radio frequency (RF) radiation exposure in the standard body worn configuration with no minimum separation. In this configuration, which applies whether the belt clip or shoulder strap is used, the face of the printer from which paper is transported is facing away from the user's body. The standard configuration must always be used when the printer is body worn.

European Regulatory Information for this Radio

AT	BE	CY	CZ	DK
EE	FI	FR	DE	GR
HU	IE	IT	LV	LT
LU	MT	NL	PL	PT
SK	SI	ES	SE	GB

Note: -Member states in the EU with restrictive use for this device are crossed out!

This device is also authorized for use in all EFTA member states (CH, IS, LI, NO)

  0168 	Important Notice: This device is a portable RF printer intended for commercial and industrial use in all EU and EFTA member states except in France where restrictive use applies.
---	--

Europe – EU Declaration of Conformity

This device complies with the essential requirements of the R&TTE Directive 1999/5/EC. The following test methods have been applied in order to prove presumption of compliance with the R&TTE Directive 1999/5/EC:

- EN55022:1998
European Immunity Standard
- EN 60950: 2000
Safety of Information Technology Equipment
- EN 300 328-2 V1.6.1 (2004-11)
Technical requirements for spread-spectrum radio equipment
- EN 301 489-1/-17 V1.5.1/1.2.1 (2003-12) -17 v1.2.1 (2002-08)
EMC requirements for spread-spectrum radio equipment.

This device is a 2.4 GHz wireless LAN transceiver, intended for indoor home and office use in all EU and EFTA member states, except in France where restrictive use applies.

The use of this frequency band in France is subject to restrictions. You may only use channels 10 and 11 (2457 and 2462 MHz) on French territory, except in those French departments as listed in the table below where channels 1-13 (2412-2472 MHz) may be used. For more information see <http://www.anfr.fr/> and/or <http://www.art-telecom.fr>

01	Ain	36	Indre	69	Rhone
02	Aisne	37	Indre et Loire	70	Haute Saone
03	Allier	39	Jura	71	Saone et Loire
05	Hautes Alpes	41	Loir et Cher	72	Sarthe
08	Ardennes	42	Loire	75	Paris
09	Ariege	45	Loiret	77	Seine et Marne
10	Aube	50	Manche	78	Yvelines
11	Aude	54	Meurthe et Moselle	79	Deux Sievres
12	Aveyron	55	Meuse	82	Tarn et Garonne
16	Charente	57	Moselle	84	Vaucluse
19	Correze	58	Nievre	86	Vienne
2A	Corse Sud	59	Nord	88	Vosges
2B	Haute Corse	60	Oise	89	Yonne
21	Cote d'Or	61	Orne	90	Territoire de Belfort
24	Dordogne	63	Puy de Dome	91	Essonne
25	Doubs	64	Pyrenees Atlantique	92	Hauts de Seine
26	Drome	65	Hautes Pyrenees	93	Seine St Denis
27	Eure	66	Pyrenees Orientales	94	Val de Marne
32	Gers	67	Bas Rhin		
35	Ille et Vilaine	68	Haute Rhin		

Zebra 802.11b WLAN Radio Module

The following section only applies when the Zebra 802.11b WLAN radio module (With FCC ID: I28MD-ZLAN11B) is installed in a QL Plus series printer (note that only one of the radio options can be installed in the printer at one time). Other than conditions specified elsewhere in this manual, only one of the radio options can be installed in the printer at one time and the antenna used for these transmitters must not be co-located or must not operate in conjunction with any other antenna.

QL Plus models have the FCC ID number on a label on the back of the unit.





Caution • The radiated output power of this internal 802.11b radio is far below the FCC radio frequency exposure limits. Nevertheless, this radio must be used in such a manner that the antenna is 2.5 cm. or further from the human body. The radio and antenna are mounted internally in this printer such that when the printer is worn with the back of the printer against the body and the front of the printer (where paper exits) away from the body, then the 2.5 cm distance between the antenna and the users body will be met. Do not use the printer in an unauthorized manner.

European Regulatory Information for this Radio

AT	BE	CY	CZ	DK
EE	FI	FR	DE	GR
HU	IE	IT	LV	LT
LU	MT	NL	PL	PT
SK	SI	ES	SE	GB

Note: -Member states in the EU with restrictive use for this device are crossed out!

This device is also authorized for use in all EFTA member states (CH, IS, LI, NO)

  0336 	Important Notice: This device is a portable RF printer intended for commercial and industrial use in all EU and EFTA member states except in France where restrictive use applies.
---	--

Europe – EU Declaration of Conformity

This device complies with the essential requirements of the R&TTE Directive 1999/5/EC. The following test methods have been applied in order to prove presumption of compliance with the R&TTE Directive 1999/5/EC:

- EN55022:1998
European Immunity Standard
- EN 60950: 2000
Safety of Information Technology Equipment
- EN 300 328-2 V1.6.1 (2004-11)
Technical requirements for spread-spectrum radio equipment
- EN 301 489-1/-17 V1.5.1/1.2.1 (2003-12) -17 v1.2.1 (2002-08)
EMC requirements for spread-spectrum radio equipment.

This device is a 2.4 GHz wireless LAN transceiver, intended for indoor home and office use in all EU and EFTA member states, except in France where restrictive use applies.

The use of this frequency band in France is subject to restrictions. You may only use channels 10 and 11 (2457 and 2462 MHz) on French territory, except in those French departments as listed in the table below where channels 1-13 (2412-2472 MHz) may be used. For more information see <http://www.anfr.fr/> and/or <http://www.art-telecom.fr>

01	Ain	36	Indre	69	Rhone
02	Aisne	37	Indre et Loire	70	Haute Saone
03	Allier	39	Jura	71	Saone et Loire
05	Hautes Alpes	41	Loir et Cher	72	Sarthe
08	Ardennes	42	Loire	75	Paris
09	Ariege	45	Loiret	77	Seine et Marne
10	Aube	50	Manche	78	Yvelines
11	Aude	54	Meurthe et Moselle	79	Deux Sievres
12	Aveyron	55	Meuse	82	Tarn et Garonne
16	Charente	57	Moselle	84	Vaucluse
19	Correze	58	Nievre	86	Vienne
2A	Corse Sud	59	Nord	88	Vosges
2B	Haute Corse	60	Oise	89	Yonne
21	Cote d'Or	61	Orne	90	Territoire de Belfort
24	Dordogne	63	Puy de Dome	91	Essonne
25	Doubs	64	Pyrenees Atlantique	92	Hauts de Seine
26	Drome	65	Hautes Pyrenees	93	Seine St Denis
27	Eure	66	Pyrenees Orientales	94	Val de Marne
32	Gers	67	Bas Rhin		
35	Ille et Vilaine	68	Haute Rhin		

WLAN Module Using 802.11g Radio

The following section only applies when the 802.11g WLAN module (With FCC ID: I28MD-ZLAN11G) is installed in a QL Plus series printer (note that only one of the radio options can be installed in the printer at one time). Other than conditions specified elsewhere in this manual, only one of the radio options can be installed in the printer at one time and the antenna used for these transmitters must not be co-located or must not operate in conjunction with any other antenna.

QL Plus models have the FCC ID number on a label on the back of the unit.



Caution • Use of a QL Plus series printer with the radio module marked with FCC ID: I28MD-ZLAN11G meets the FCC requirements for radio frequency (RF) radiation exposure in the standard body worn configuration with no minimum separation. In this configuration, which applies whether the belt clip or shoulder strap is used, the face of the printer from which paper is transported is facing away from the user's body. The standard configuration must always be used when the printer is body worn.

The QL 220 Plus, QL 320 Plus, and QL 420 Plus printers with this radio option have been SAR tested. The maximum SAR value measured for each model is listed below:

Model	SAR value W/Kg (1g average)
QL220 Plus	0.005
QL 320 Plus	0.002
QL 420 Plus	0.004

European Regulatory Information for this Radio

AT	BE	CY	CZ	DK
EE	FI	FR	DE	GR
HU	IE	IT	LV	LT
LU	MT	NL	PL	PT
SK	SI	ES	SE	GB

Note: -Member states in the EU with restrictive use for this device are crossed out!

This device is also authorized for use in all EFTA member states (CH, IS, LI, NO)

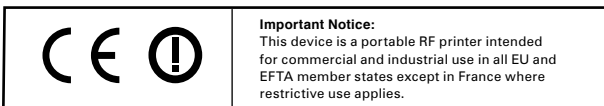

Europe – EU Declaration of Conformity

This device complies with the essential requirements of the R&TTE Directive 1999/5/EC. The following test methods have been applied in order to prove presumption of compliance with the R&TTE Directive 1999/5/EC:

- EN55022:1998

European Immunity Standard

- EN 60950: 2000

Safety of Information Technology Equipment

- EN 300 328-2 V1.2.1 (2001-12)

Technical requirements for spread-spectrum radio equipment

- EN 301 489-17 V1.2.1 (2002-08)

EMC requirements for spread-spectrum radio equipment.

This device is a 2.4 GHz wireless LAN transceiver, intended for indoor home and office use in all EU and EFTA member states, except in France where restrictive use applies.

The use of this frequency band in France is subject to restrictions. You may only use channels 10 and 11 (2457 and 2462 MHz) on French territory, except in those French departments as listed in the table below where channels 1-13 (2412-2472 MHz) may be used. For more information see <http://www.anfr.fr/> and/or <http://www.art-telecom.fr>

01	Ain	36	Indre	69	Rhone
02	Aisne	37	Indre et Loire	70	Haute Saone
03	Allier	39	Jura	71	Saone et Loire
05	Hautes Alpes	41	Loir et Cher	72	Sarthe
08	Ardennes	42	Loire	75	Paris
09	Ariege	45	Loiret	77	Seine et Marne
10	Aube	50	Manche	78	Yvelines
11	Aude	54	Meurthe et Moselle	79	Deux Sievres
12	Aveyron	55	Meuse	82	Tarn et Garonne
16	Charente	57	Moselle	84	Vaucluse
19	Correze	58	Nievre	86	Vienne
2A	Corse Sud	59	Nord	88	Vosges
2B	Haute Corse	60	Oise	89	Yonne
21	Cote d'Or	61	Orne	90	Territoire de Belfort
24	Dordogne	63	Puy de Dome	91	Essonne
25	Doubs	64	Pyrenees Atlantique	92	Hauts de Seine
26	Drome	65	Hautes Pyrenees	93	Seine St Denis
27	Eure	66	Pyrenees Orientales	94	Val de Marne
32	Gers	67	Bas Rhin		
35	Ille et Vilaine	68	Haute Rhin		

Compact Flash (802.11b) and Bluetooth Co-located Radio Modules

The following section only applies when the CF (Compact Flash) WLAN module (FCC ID: H9PLA4137) and Bluetooth module (FCC ID: I28MD-BTC2TY4) are installed in a QL 220 Plus or QL 420 Plus printer. This co-located radio configuration has demonstrated compliance to FCC regulations. The FCC ID numbers are on the serial number label on the back of the printer and can be read with the module installed.



Caution • Use of a QL 220 Plus or QL 420 Plus printer with the radio module marked with both “FCC ID: H9PLA4137” and “I28MD-BTC2TY4” meets the FCC requirements for radio frequency (RF) radiation exposure in the standard body worn configuration with no minimum separation. In this configuration, which applies whether the belt clip or shoulder strap is used, the face of the printer from which paper is transported is facing away from the user’s body. The standard configuration must always be used when the printer is body worn. QL 220 Plus and QL 420 Plus printers with this radio option have been SAR tested. The maximum measured SAR values are listed below.

Model	SAR value W/Kg (1g average)
QL220 Plus	0.01
QL 420 Plus	0.39

European Regulatory Information for Co-located Radios

AT	BE	CY	CZ	DK
EE	FI	FR	DE	GR
HU	IE	IT	LV	LT
LU	MT	NL	PL	PT
SK	SI	ES	SE	GB

Note: -Member states in the EU with restrictive use for this device are crossed out!

This device is also authorized for use in all EFTA member states (CH, IS, LI, NO)

	<p>Important Notice: This device is a portable RF printer intended for commercial and industrial use in all EU and EFTA member states except in France where restrictive use applies.</p>
--	--

Europe – EU Declaration of Conformity

This device complies with the essential requirements of the R&TTE Directive 1999/5/EC. The following test methods have been applied in order to prove presumption of compliance with the R&TTE Directive 1999/5/EC:

- EN55022:1998
European Immunity Standard
- EN 60950: 2000
Safety of Information Technology Equipment
- EN 300 328-2 V1.2.1 (2001-12)
Technical requirements for spread-spectrum radio equipment
- EN 301 489-17 V1.2.1 (2002-08)
EMC requirements for spread-spectrum radio equipment.

This device is a 2.4 GHz wireless LAN transceiver, intended for indoor home and office use in all EU and EFTA member states, except in France where restrictive use applies.

The use of this frequency band in France is subject to restrictions. You may only use channels 10 and 11 (2457 and 2462 MHz) on French territory, except in those French departments as listed in the table below where channels 1-13 (2412-2472 MHz) may be used. For more information see <http://www.anfr.fr/> and/or <http://www.art-telecom.fr>

01	Ain	36	Indre	69	Rhone
02	Aisne	37	Indre et Loire	70	Haute Saone
03	Allier	39	Jura	71	Saone et Loire
05	Hautes Alpes	41	Loir et Cher	72	Sarthe
08	Ardennes	42	Loire	75	Paris
09	Ariege	45	Loiret	77	Seine et Marne
10	Aube	50	Manche	78	Yvelines
11	Aude	54	Meurthe et Moselle	79	Deux Sievres
12	Aveyron	55	Meuse	82	Tarn et Garonne
16	Charente	57	Moselle	84	Vaucluse
19	Correze	58	Nievre	86	Vienne
2A	Corse Sud	59	Nord	88	Vosges
2B	Haute Corse	60	Oise	89	Yonne
21	Cote d'Or	61	Orne	90	Territoire de Belfort
24	Dordogne	63	Puy de Dome	91	Essonne
25	Doubs	64	Pyrenees Atlantique	92	Hauts de Seine
26	Drome	65	Hautes Pyrenees	93	Seine St Denis
27	Eure	66	Pyrenees Orientales	94	Val de Marne
32	Gers	67	Bas Rhin		
35	Ille et Vilaine	68	Haute Rhin		

Using the Accessories

Belt Clip

Refer to Figure 17. All QL Plus printers have a belt clip installed as a standard feature. To use: hook the clip over your belt, and ensure that the clip is securely attached to the belt. The belt clip will pivot to allow you to move freely while wearing the printer.

The retainer for the Belt Clip has a strain relief feature which can be used with the communications cable. Refer to the section on Connecting the Printer.

Figure 17: Using the Belt Clip

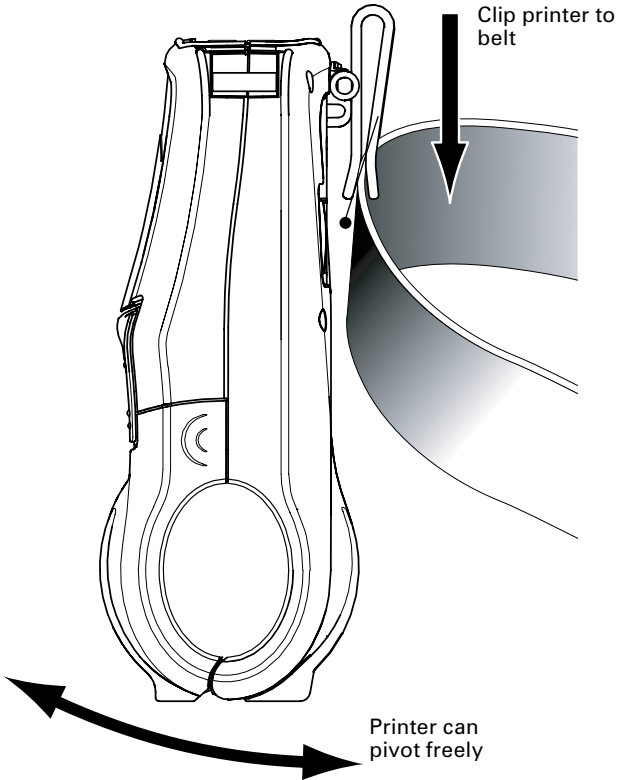

Kickstand

Refer to Figure 18. The Kickstand option allows users to use the printer on a desktop. To use the optional Kickstand: Flip the Kickstand on the back of the printer open until you feel a slight detent. The printer will now sit at approximately a 30° to 45° angle on a desktop depending on the printer model.

The retainer for the Kickstand has strain relief features which can be used with the communications cable. Refer to the section on Connecting the Printer.

Caution • Do not use the printer while charging a battery with the LI72 charger.

Figure 18: Using the Kickstand

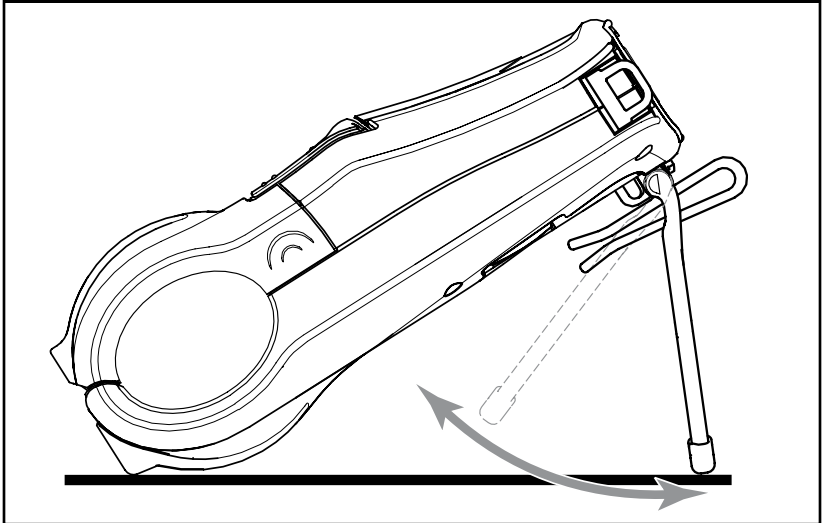
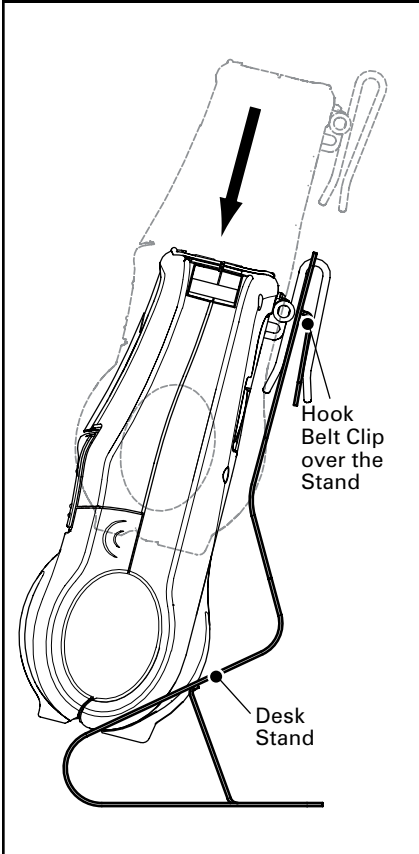

Figure 19: Using the Optional Desk Stand



Desk Stand

Refer to Figure 19. To use the Desk Stand: Slide the printer onto the Desk Stand. The printer's belt clip will hook onto the Desk Stand as shown and retain it in place. Ensure that the clip is securely attached to the Stand and the media compartment of the printer is seated securely in the Stand.

Holes are provided to permanently attach the Desk Stand to the work surface. Charger and data I/O cables may be plugged into the printer in the usual manner.

Caution • Do not use the printer while charging a battery with the LI72 charger.

Adjustable Shoulder Strap

Refer to Figure 20 if your printer is equipped for the shoulder strap option. Snap each end of the shoulder strap into the "D" rings in the top of the printer. Hold the buckle and pull the strap as shown below until you achieve the desired length.

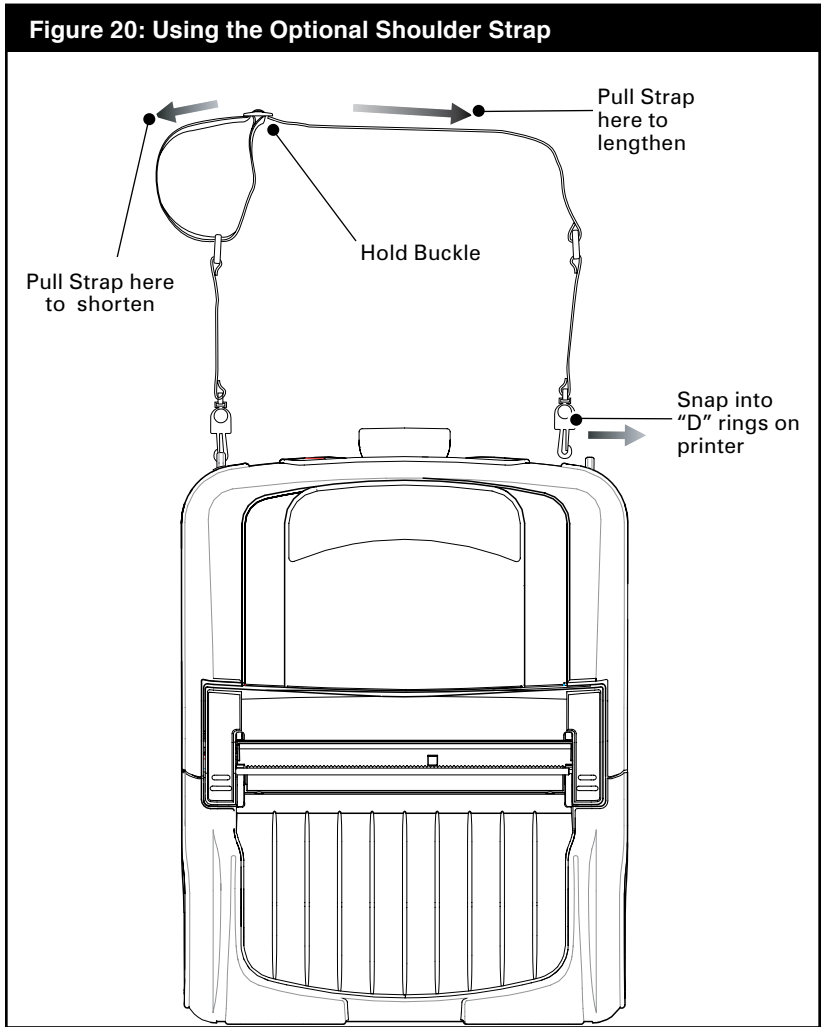

Carrying Strap

Refer to Figures 21 and 21a. There are two varieties of carrying strap. One of them clips onto the printer's "D" rings as does the shoulder strap, and the other is secured to the printer permanently with loops in the strap secured by sleeves captured between the printer's upper and lower covers.

Either strap provides the user with a convenient and secure method of carrying the printer.

Figure 21: Detachable Carrying Strap

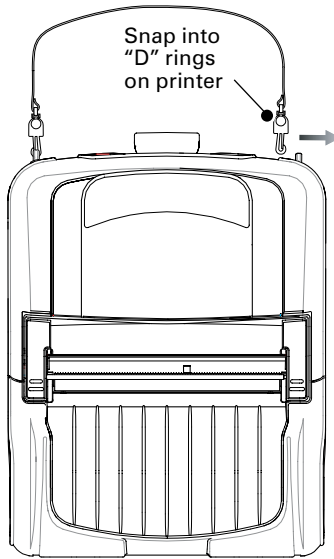
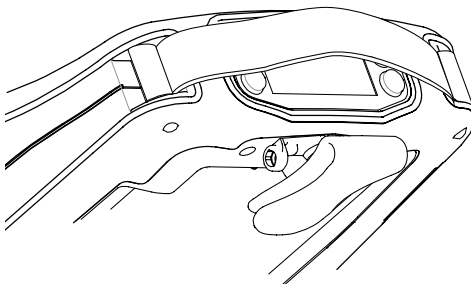

Figure 21a: Permanent Carrying Strap



Preventive Maintenance

Extending Battery Life

- Never expose the battery to direct sunlight or temperatures over 104° F (40° C).
- Do not charge the battery when the temperature exceeds 113° F (45° C).
- Always use a Zebra charger designed specifically for Lithium-Ion batteries. Use of any other kind of charger may damage the battery.
- Use the correct media for your printing requirements. An authorized Zebra re-seller can help you determine the optimum media for your application.
- If you print the same text or graphic on every label, consider using a pre-printed label.
- Choose the correct print darkness, and print speed for your media.
- Use software handshaking (XON/XOFF) whenever possible.
- Select Tear-Off mode whenever possible (Peel-Off mode uses more power).
- If your printer has the optional LCD display, use the display backlight only when necessary. Turn it off whenever it is not needed.
- Remove the battery if the printer won't be used for a day or more and you're not performing a maintenance charge.
- Consider purchasing an extra battery.
- Remember that any rechargeable battery will lose its ability to maintain a charge over time. It can only be recharged a finite number of times before it must be replaced. Always dispose of batteries properly. Refer to Appendix E for more information on battery disposal.

Caution • Do not print while the LI72 Wall Charger is plugged into the unit. Unreliable battery charging can result.

General Cleaning Instructions



Caution • Avoid possible personal injury or damage to the printer: never insert any pointed or sharp objects into the printer. Always turn the printer off before performing any cleaning procedures.
Use care when working near the tear bar. The edges are very sharp.



Caution • The printhead can be very hot after prolonged printing. Allow it to cool off before attempting any cleaning procedures.



Only use the cleaning pen supplied with the printer or a cotton swab saturated with alcohol for cleaning the printhead.

Caution • Use only cleaning agents specified in the following tables. Zebra Technologies Corporation will not be responsible for damage caused by any other cleaning materials used on this printer.

QL 220 Plus Cleaning		
Area	Method	Interval
Printhead (Figure 22)	Use the supplied cleaning pen or 70% isopropyl alcohol on a cotton swab to clean the print elements from end to end (the print elements are located in the thin gray line on the printhead).	After every five rolls of media (or more often, if needed), Linerless media requires more frequent cleaning
Platen Roller (Figure 22)	Rotate the platen roller and clean it thoroughly with the cleaning pen or 70% isopropyl alcohol and a cotton swab.	
Platen Roller (Figure 22a)	Units with linerless platens: Rotate platen & clean bearing points only. <i>Avoid use of alcohol on the surface of linerless platens</i>	
Peel bar (Figure 22)	Clean thoroughly with the cleaning pen or 70% isopropyl alcohol and a cotton swab.	As needed
Scraper, Linerless units only (Figure 22)		After every five rolls of media (or more often, if needed)
Tear bar (Figure 22)		
Exterior	Water-dampened cloth	
Interior (Figure 22)	Brush/air blow. Ensure the Bar Sensor, Gap Sensor and Label Present Sensor windows are free of dust.	As needed
Interior (Figure 22a)	Units with linerless platens: Clean inside surfaces of edge guides & media rollers with the supplied cleaning pen or 70% isopropyl alcohol on a cotton swab.	After every five rolls of media (or more often, if needed)

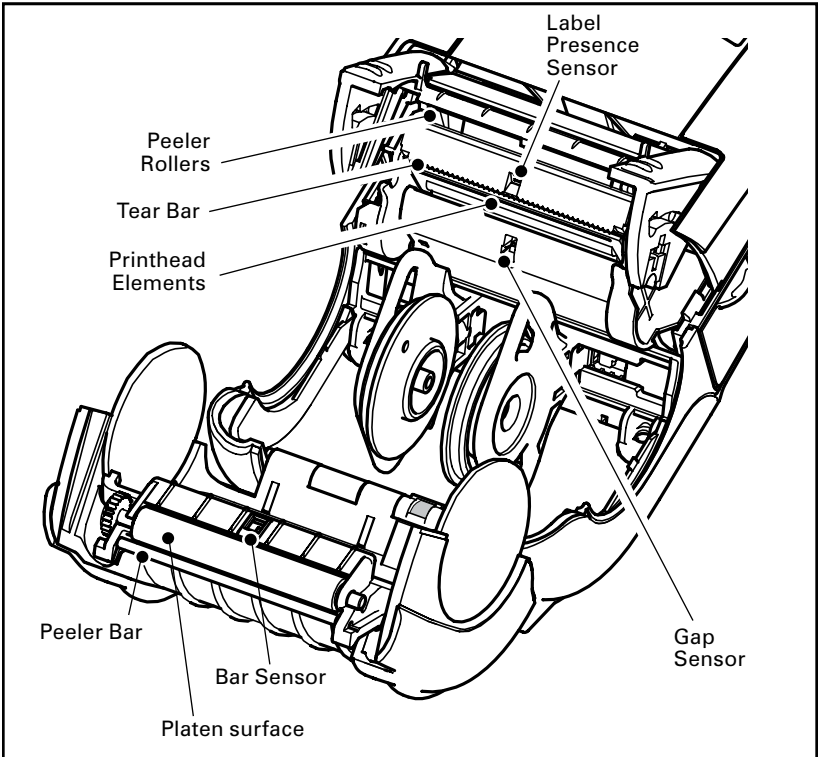

Figure 22: Cleaning the QL 220 Plus

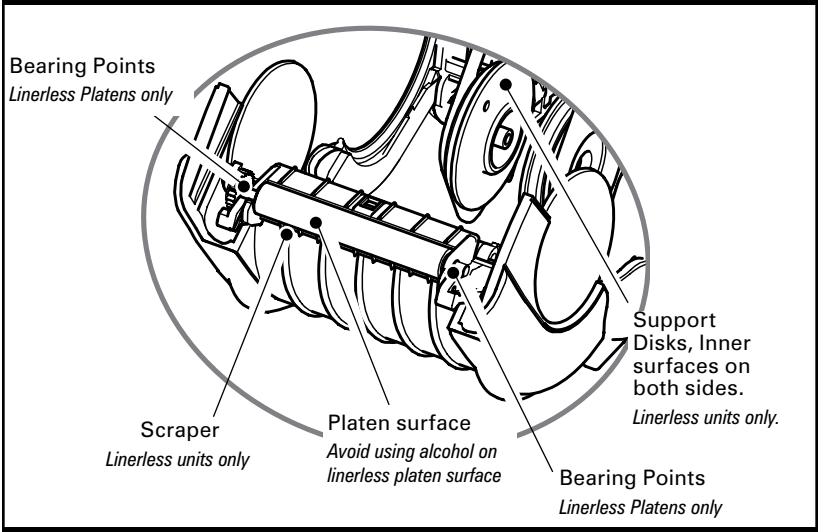
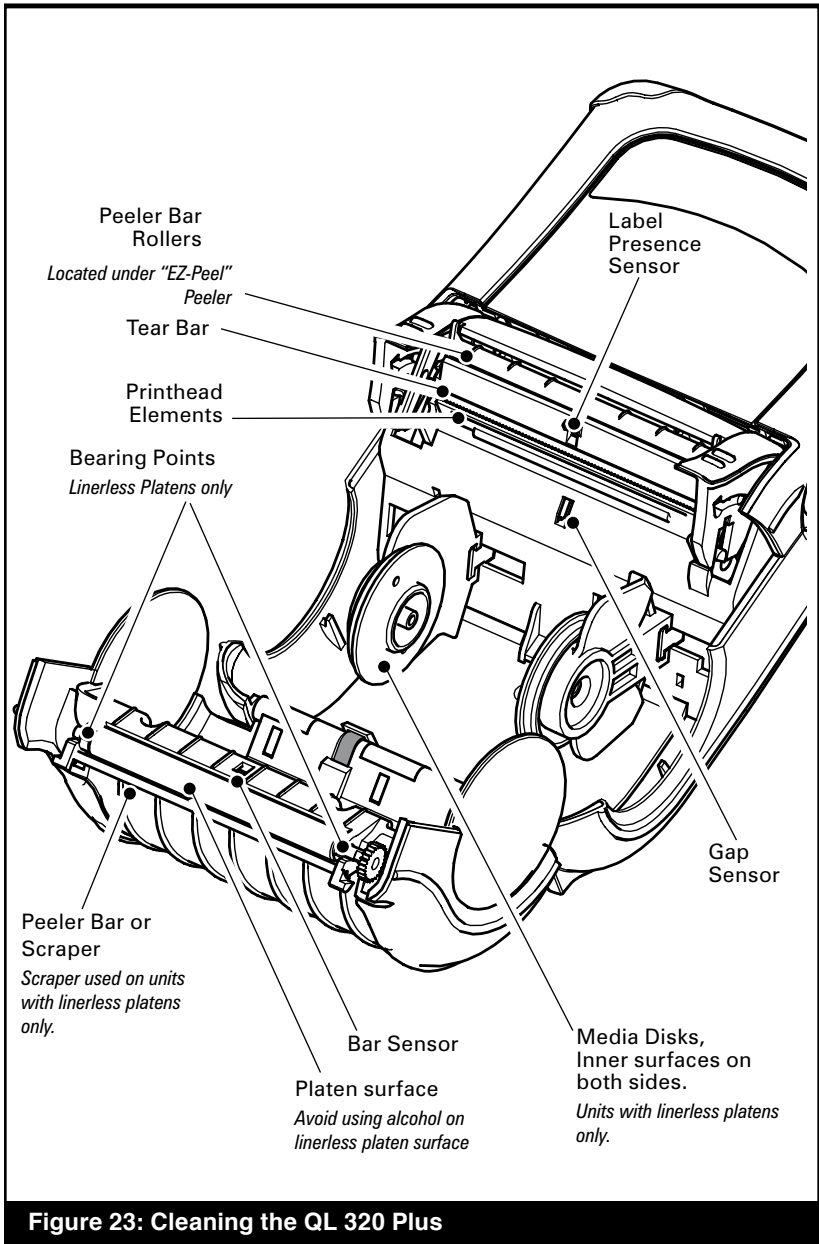

Figure 22a: Cleaning the Linerless QL 220 Plus

QL 320 Plus Cleaning

Area	Method	Interval
Printhead (Figure 23)	Use the supplied cleaning pen or 70% isopropyl alcohol on a cotton swab to clean the print elements from end to end (the print elements are located in the thin gray line on the printhead).	After every five rolls of media (or more often, if needed), Linerless media requires more frequent cleaning
Platen Roller (Figure 23)	Rotate the platen roller and clean it thoroughly with the cleaning pen or 70% isopropyl alcohol and a cotton swab.	
		Units with linerless platens: Rotate platen & clean bearing points only. <i>Avoid use of alcohol on the surface of linerless platens</i>
Peel bar (Figure 23)	Clean thoroughly with the cleaning pen or 70% isopropyl alcohol and a cotton swab.	As needed
Scraper, Linerless units only (Figure 23)		After every five rolls of media (or more often, if needed)
Tear bar (Figure 23)		
Exterior	Water-dampened cloth	
Interior (Figure 23)	Brush/air blow. Ensure the Bar Sensor, Gap Sensor and Label Present Sensor windows are free of dust.	As needed
	Units with linerless platens: Clean inside surfaces of edge guides & media rollers with the supplied cleaning pen or 70% isopropyl alcohol on a cotton swab.	After every five rolls of media (or more often, if needed)



QL 420 Plus Cleaning

Area	Method	Interval
Printhead (Figure 24)	Use the supplied cleaning pen or 70% isopropyl alcohol on a cotton swab to clean the print elements from end to end (the print elements are located in the thin gray line on the printhead).	After every five rolls of media (or more often, if needed), Linerless media requires more frequent cleaning
Platen Roller (Figure 24)	Rotate the platen roller and clean it thoroughly with the cleaning pen or 70% isopropyl alcohol and a cotton swab.	
	Units with linerless platens: Rotate platen & clean bearing points only. <i>Avoid use of alcohol on the surface of linerless platens</i>	
Peel bar (Figure 24)	Clean thoroughly with the cleaning pen or 70% isopropyl alcohol and a cotton swab.	As needed
Scraper, Linerless units only (Figure 24)		After every five rolls of media (or more often, if needed)
Tear bar (Figure 24)		
Exterior	Water-dampened cloth	
Interior (Figure 24)	Brush/air blow. Ensure the Bar Sensor, Gap Sensor and Label Present Sensor windows are free of dust.	As needed
	Units with linerless platens: Clean inside surfaces of edge guides & media rollers with the supplied cleaning pen or 70% isopropyl alcohol on a cotton swab.	After every five rolls of media (or more often, if needed)
Media Rollers (Figure 24)	Clean thoroughly with the cleaning pen or 70% isopropyl alcohol and a cotton swab.	
	Units with linerless platens: Rotate media rollers & clean bearing points only. <i>Avoid use of alcohol on the surface of the media rollers!</i>	

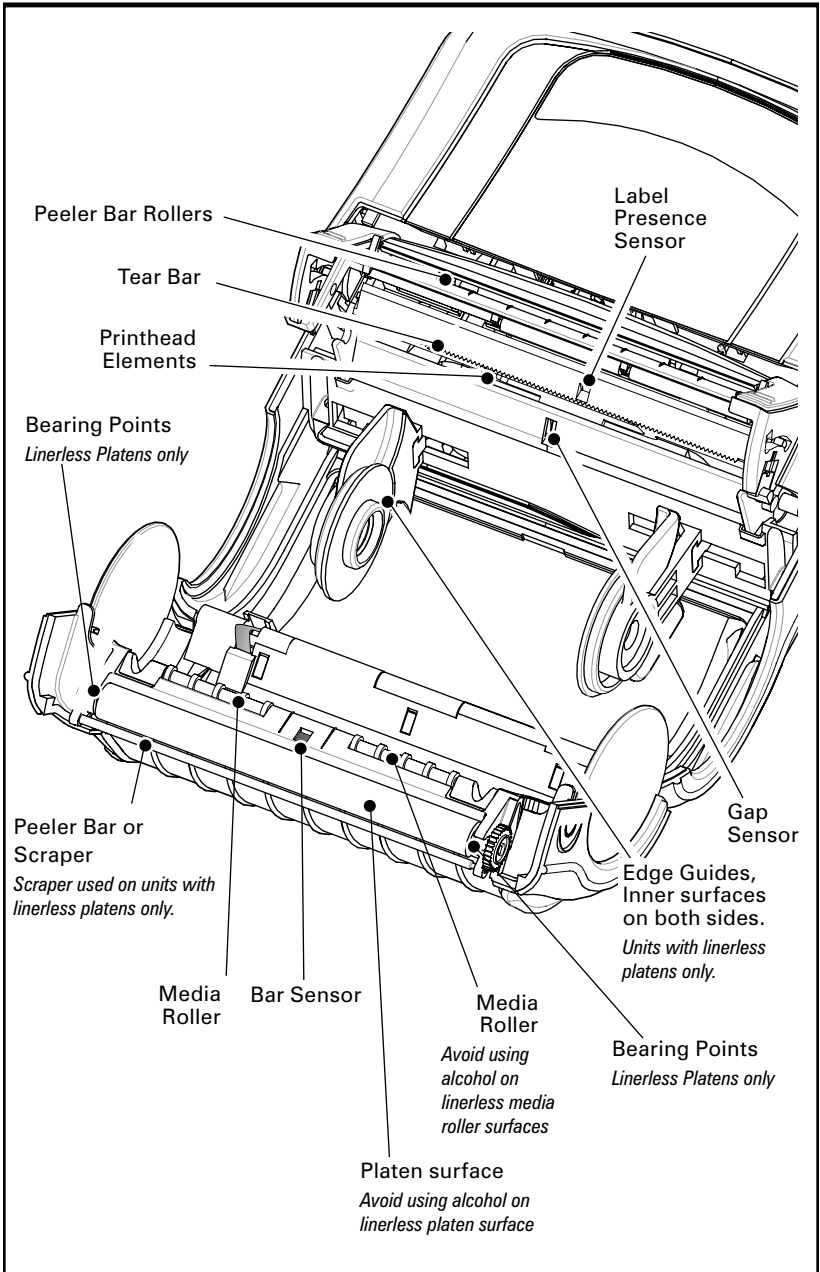
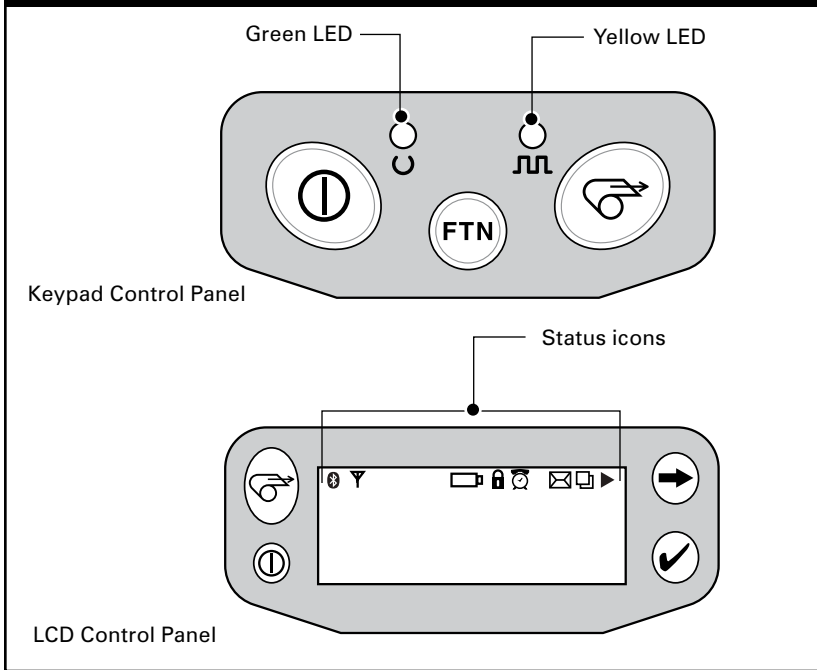

Figure 24: Cleaning the QL 420 Plus

Troubleshooting

Figure 25 QL Plus Control Panels











Keypad Control Panel

If the printer is not functioning properly, refer to the chart below to find the state of the two LEDs on the Keypad Control Panel. Then refer to the Troubleshooting topic referenced in the chart to resolve the problem.

Green LED	Yellow LED	Indication	Ref. to Topic
Steady	Off	Normal Operation, and/or RF Link established	n/a
Off	Off	Power Off	1
Fast Blink	Off	No RF Link	6, 11
Slow Blink	Off	Low Battery	3, 6, 7
Steady	Steady	Out of media, or Media Cover not closed	9, 11
Steady	Fast Blink	Normal RF activity	8
Steady	Fast Blink , Beeper Sounds	No application	8

LCD Control Panel Indicators

The top of the display shows several icons which indicate the status of various printer functions. Check the indicator status, then refer to the Troubleshooting topic referenced in the chart to resolve the problem.

Icon	Status	Indication	Ref. to Topic #
	On	Bluetooth Link established	n/a
	Off	No Bluetooth Link	6
	On	Bluetooth link established	n/a
	Off	No Bluetooth link	6
	Flashing	Transmitting/Receiving data	n/a
	On	802.11b/g RF Link established	n/a
	Off	No 802.11b/g RF Link	6
	Flashing	Low Battery	3, 6, 7
	Flashing	Head latch not closed	9, 11
	Flashing	Indicates Printing activity	n/a
	Steady	data processing in process	8
	Flashing	Out of Media	9,11
	Blank Screen	n/a	No application



QL Plus printers may have one of two LCD types. LCDs using the Bluetooth icon (highlighted by a gray background in the table above) will gradually replace LCDs with the “light bulb” icon indicating Bluetooth activity. Printers with either type of display will function identically.

The “right facing” arrow icon will be activated in both LCD versions on printers with the latest firmware updates.

continued

Troubleshooting Topics

1. No power

- Check that battery is installed properly.
- Recharge or replace battery as necessary.



Always dispose of batteries properly. Refer to Appendix E for more information on proper battery disposal.

2. Media does not feed:

- Be sure print head is closed and latched.
- Check spindle holding media for any binding.
- If unit is equipped with label presence sensor:
Ensure most recently printed label is removed.
Also ensure label sensor is not blocked.

3. Poor or faded print or flashing:

- Clean print head.
- Check battery and recharge or replace as necessary.
Always dispose of batteries properly. Refer to Appendix D for more information on proper battery disposal.
- Check quality of media.

4. Partial or missing print:

- Check media alignment
- Clean print head.
- Ensure printhead is properly closed and latched.

5. Garbled print:

- Check baud rate.

6. No print:

- Check baud rate.
- Replace battery.
- Check cable to terminal.
- Establish RF Link (Wireless units only) and/or restore LAN associativity (Printers with WLAN radios only).
- Invalid label format or command structure. Place printer in Communications Diagnostic (Hex Dump) Mode to diagnose problem.

7. Reduced battery charge life

- Check battery date code — if battery is one to two years old, short charge life may be due to normal aging.
- Recondition battery.
- Replace battery.

8. Yellow error light or  flashing:

- No application or application corrupted: reload program.
- If using wireless communications: flashing indicator is normal while data is being transmitted or received.

9. Yellow error light always on,  or  flashing:

- Check that media is loaded and that the print head is closed and securely latched.

10. Skips labels:

- Check media for top of form sense mark or label gap.
- Check that the maximum print field has not been exceeded on label.
- Ensure bar or gap sensor is not blocked or malfunctioning

11. Communication error:

- Check media is loaded, head is closed and error light is off.
- Check baud rate.
- Replace cable to terminal.

12. Label jam:

- Open head release latch and media cover.
- Generously apply alcohol to printer in area of jammed label.

13. Blank LCD screen (only for units with LCD control panel)

- No application loaded or application corrupted: reload program.

Troubleshooting Tests

Printing a Configuration Label

To print out a listing of the printer's current configuration follow these steps:

1. Turn the printer off. Load the media compartment with journal media (media with no black bars printed on the back).
2. Press and hold the Feed Button.
3. Press and release the Power button and keep the Feed button pressed. When printing starts, release the Feed button.

Refer to Figure 26 for sample configuration printouts.

Communications Diagnostics

If there is a problem transferring data between the computer and the printer, try putting the printer in the Communications Diagnostics Mode (also referred to as the "DUMP" mode). The printer will print the ASCII characters and their text representation (or the period '.', if not a printable character) for any data received from the host computer.

To enter Communications Diagnostics Mode:

1. Print a configuration label as described above.
2. At the end of 2nd diagnostics report, the printer will print: "Press FEED key to enter DUMP mode".
3. Press the FEED key. The printer will print: "Entering DUMP mode".



Note • *If the FEED key is not pressed within 3 seconds, the printer will print "DUMP mode not entered" and will resume normal operation.*

4. At this point, the printer is in DUMP mode and will print the ASCII hex codes of any data sent to it, and their text representation (or "." if not a printable character).

Additionally, a file with a ".dmp" extension containing the ASCII information will be created and stored in the printer's memory. It can be viewed, "cloned" or deleted using the Label Vista application. (Refer the Label Vista documentation for more information.)

To terminate the Communications Diagnostics Mode and return the printer to normal operations:

1. Turn the printer OFF.
2. Wait 5 seconds.
3. Turn the printer ON.

Contacting Technical Support

If the printer fails to print the configuration label, or you encounter problems not covered in the Troubleshooting Guide, contact Zebra Technical Support. Technical Support addresses and phone numbers for your area can be found in Appendix D of this manual. You will need to supply the following information:

- Model number and type (e.g. QL 420 Plus)
- Unit serial number (Found on the large label on the back of the printer, also found in the configuration label print-out. Refer to Figure 26)
- Product Configuration Code (PCC) (15 digit number found on the label on the back of the unit)

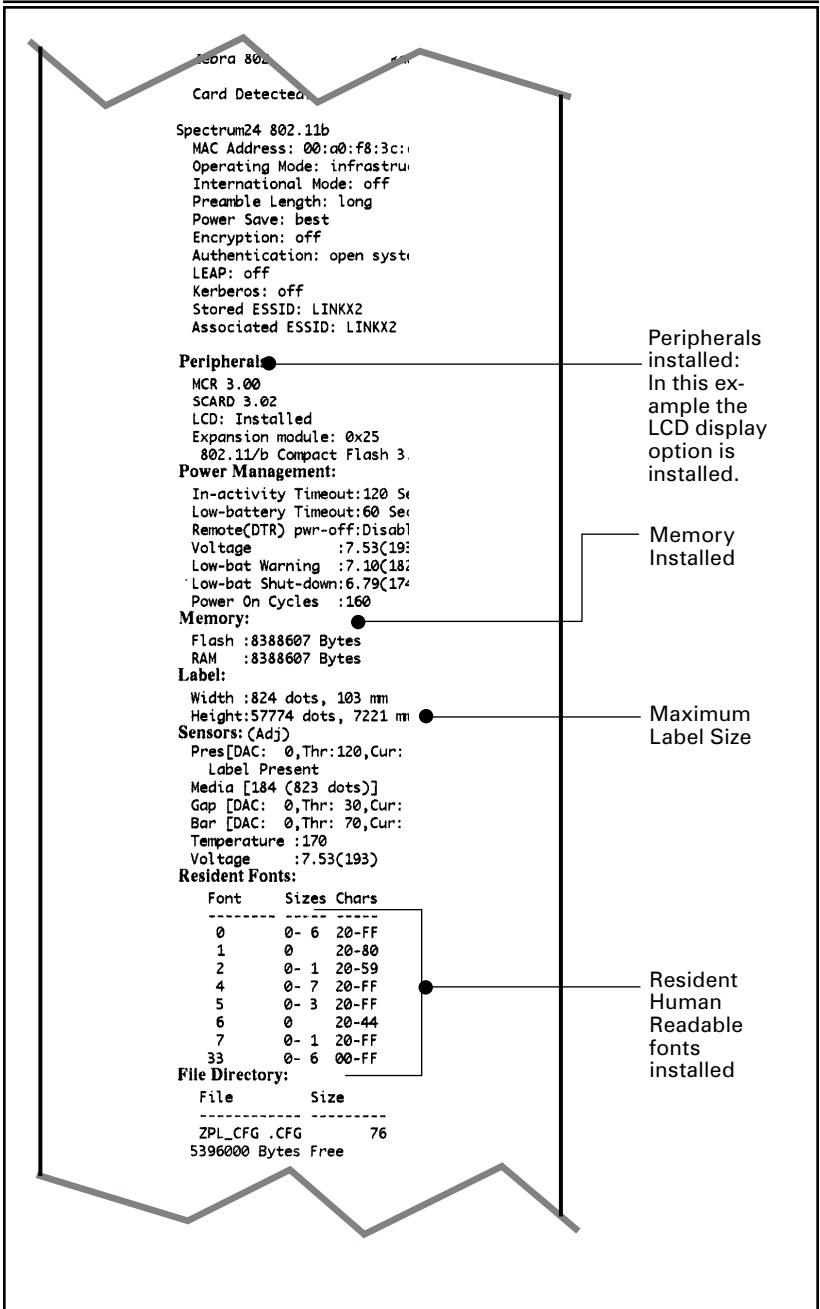

Figure 26a: QL Plus Configuration Label Example (continued)

continued

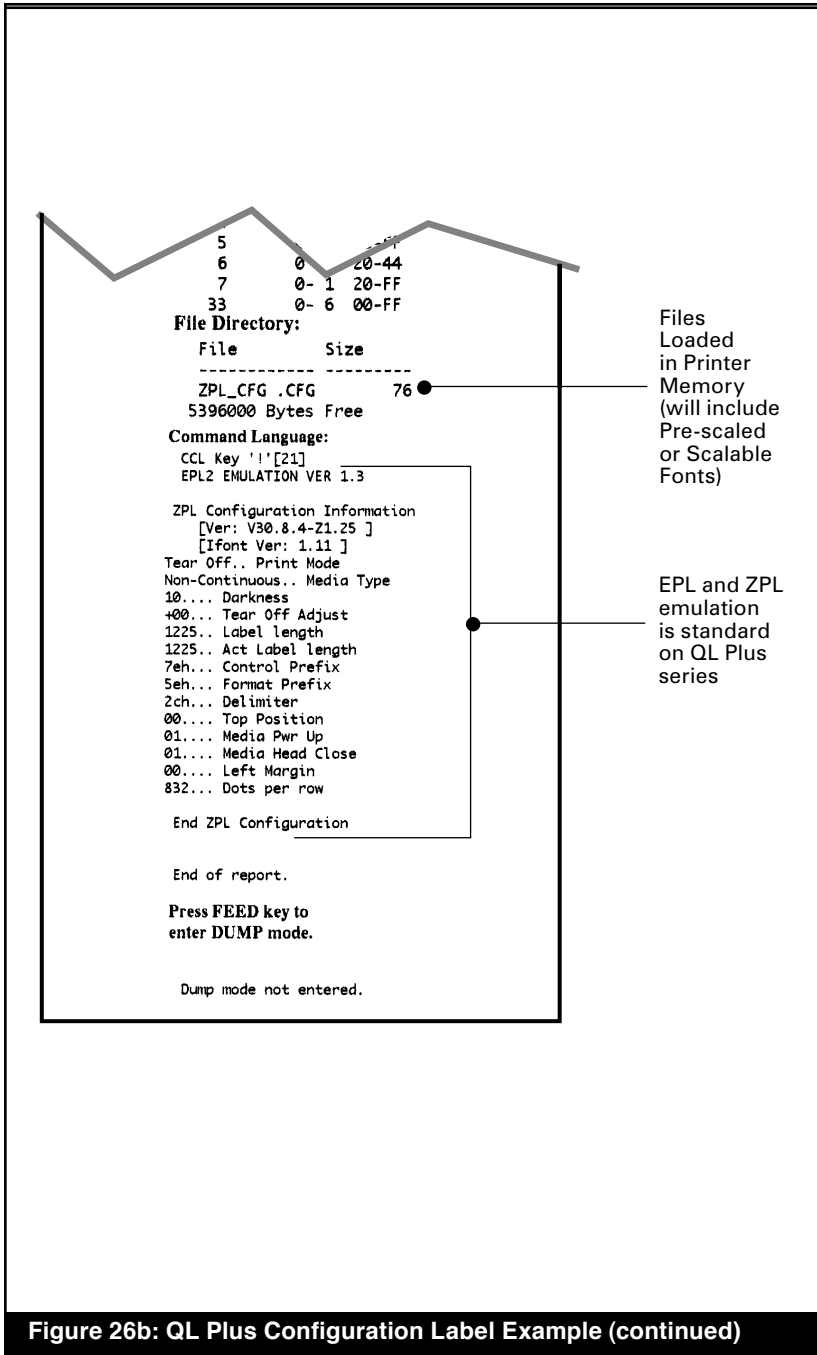

Figure 26b: QL Plus Configuration Label Example (continued)

Specifications



Note.- Printer specifications are subject to change without notice.

Printing Specifications

Parameter	QL 220 Plus	QL 320 Plus	QL 420 Plus
Print Width	Up to 1.89 in. (48 mm)	Up to 2.9 in. (71.2 mm)	Up to 4.09 in. (103.8 mm)
Print Speed	3 in./second (76.2 mm/second)	4 in./second (101.6 mm/second)	3 in./second (76.2 mm/second)
Distance from Print Element to Top of Form	0.445 in. (11.3 mm) 89 dots	0.571 in. (14.5 mm) 116 dots	0.571 in. (14.5 mm) 116 dots
Print Head Life, calculated	1,964,160 in. (50 Km) nominal		
Print Density	203 dots/inch (8 dots/mm)		

Memory and Communications Specifications

Flash Memory	4 MB flash (standard)
RAM Memory	8 MB RAM (standard)
Standard Communications	RS-232 serial port (8 Pin circular DIN connector) Configurable Baud rate (from 9600 to 57.6 Kbps), parity and data bits. Software (X-ON/X-OFF) or hardware (DTR/STR) communication handshake protocols.
	USB 2.0 Full Speed Interface (12 Mbps)
Optional Wireless Communications	Infrared wireless link meets IrDA 1.1 communications specifications: 2,400 to 115,200 Baud rate
	Bluetooth compatible 2.4 GHz SRRF link
Real Time Clock (RTC)	Optional wireless LAN capabilities comply with 802.11b/g protocols
	Time and date under application control. Refer to CPCL Programming Manual, available at www.zebra.com/manuals for RTC commands.

Label Specifications

Parameter	QL220 Plus	QL 320 Plus	QL 420 Plus
Label or Tag Width	0.75 in. to 2.12 in. (16 to 53.8 mm)	1.5 in. to 3.1 in. (38.1 to 78.4 mm)	2 in. to 4.1 in. (50.8 to 104.1 mm)
Max. Label/ Tag Length (w/std. memory)	20 in. (508 mm)	16 in. (406.4 mm)	20 in. (508 mm)
Inter-label Gap.	0.08 in. to 0.16 in. (.12 in. preferred) (2 mm to 4 mm, 3 mm preferred)		
Label Thickness	0.0025 in to 0.0065 in (0.064 mm to .165 mm)		
Tag Thickness	0.0060 in. (0.152 mm) maximum		
Max. Label Roll dia.	2.20 (55.8 mm) O.D.	2.63 in. (66.8 mm) O.D.	
Label Inner Core	0.75 in. (19 mm) minimum dia;		
	1.38 in. (35.05 mm) minimum dia. for linerless media (QL 420 Plus accepts linerless media on 0.75 in. cores.)		
Black Mark Dimensions	The reflective media black marks should extend past the center-line of the roll.		
Media Requirements	Minimum mark width: 0.5 in. (12.7 mm) perpendicular to edge of media, centered within the width of the roll. Mark length: 0.094 in. (2.4 mm) parallel to edge of media		



Use Zebra brand direct thermal media that is outside wound. Media may be reflective (black mark) sensing, or transmissive (gap) sensing, die-cut, continuous, or linerless. QL 420 Plus models will accept fanfold media if used with an external media supply.

For die-cut labels, use only full auto dies.

Font and Bar Code Specifications

Standard Fonts	25 bit-mapped fonts; 1 scalable font (CG Trimvirate Bold Condensed*) Downloadable optional bit-mapped & scalable fonts via Label Vista software.		
Available Optional Fonts	Optional International character sets: Chinese 16 x 16 (trad), 16 x 16 (simplified), 24 x 24 (simplified); Japanese 16 x 16, 24 x 24; Hebrew/Arabic		
Linear Bar Codes Available	Codabar		
	UCC/EAN 128		
	Code 39		
	Code 93		
	EAN 8/JAN 8, 2 and 5 digit extensions		
	EAN 13/JAN 13, 2 and 5 digit extensions		
	EAN-8 Composite		
	EAN-13 Composite		
	Interleaved 2 of 5		
	MSI/Plessey		
	FIM/POSTNET		
	UPC-A, 2 and 5 digit extensions		
	UPCA Composite		
	UPC E, 2 and 5 digit extensions		
	UPCE Composite		
2-D Bar Codes Available	MaxiCode		
	PDF 417		
	Datamatrix (using ZPL emulation)		
	QR Code		
	RSS:	RSS-14 Truncated	
		RSS-14 Stacked	
		RSS-14 Stacked Omnidirectional	
RSS Limited			
RSS Expanded			
Rotation Angles	0°, 90°, 180°, and 270°		

*Contains UFST from Agfa Monotype Corporation

Communications Ports

RS-232C

Pin#	Signal Name	Type	Description
1	RXD	input	Receive Data
2	TXD	output	Transmit Data
3	CTS	input	Clear To Send from host
4	RTS	output	Request To Send set high when printer is ready to accept a command or data
5	GND		Ground
6	NC		No Connect
7	DSR	input	Data Set Ready: low to high transition turns printer on, high to low transition turns printer off (if enabled)
8	DTR	output	Data Terminal Ready: set high when printer is on. Set to battery voltage for "S" versions (compatible with Symbol™ PIM)

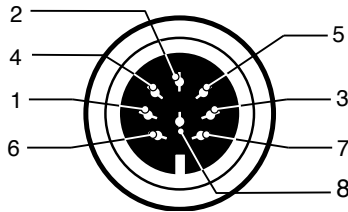

Figure 27: RS-232C Communications Port (8 pin Circular DIN)

USB

Pin #	Signal Name	Type	Description
1	VBUS	-	USB Bus Power
2	USB -	bi-directional	I/O signals
3	USB +	bi-directional	I/O signals
4	USB_ID	-	Identifies A/B connector
5	Return		Ground

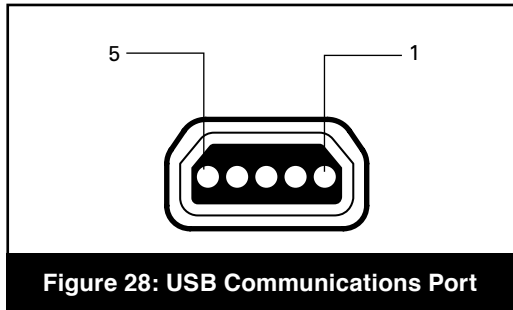

Figure 28: USB Communications Port

Physical, Environmental and Electrical Specifications

Parameter	QL 220 Plus	QL 320 Plus	QL 420 Plus
Weight w/ battery, excluding media & wireless options.	1.1 lbs. (0.50 kg.)	1.65 lbs. (0.75 kg.)	2.0 lbs. (0.9 kg.)
Temperature	Operating : 5° to 122° F (-15° to 50° C)		
	Storage: -13° to 158° F (-25° to 70° C) Range		
Relative Humidity	Operating: 10% to 80% (non-condensing)		
	Storage: 10% to 90% (non-condensing)		
Battery	Lithium-Ion, 7.4 VDC (nominal); 2 Ahr.		Lithium-Ion, 7.4 VDC (nominal); 4 Ahr
Intrusion Protection (IP) Rating	14		

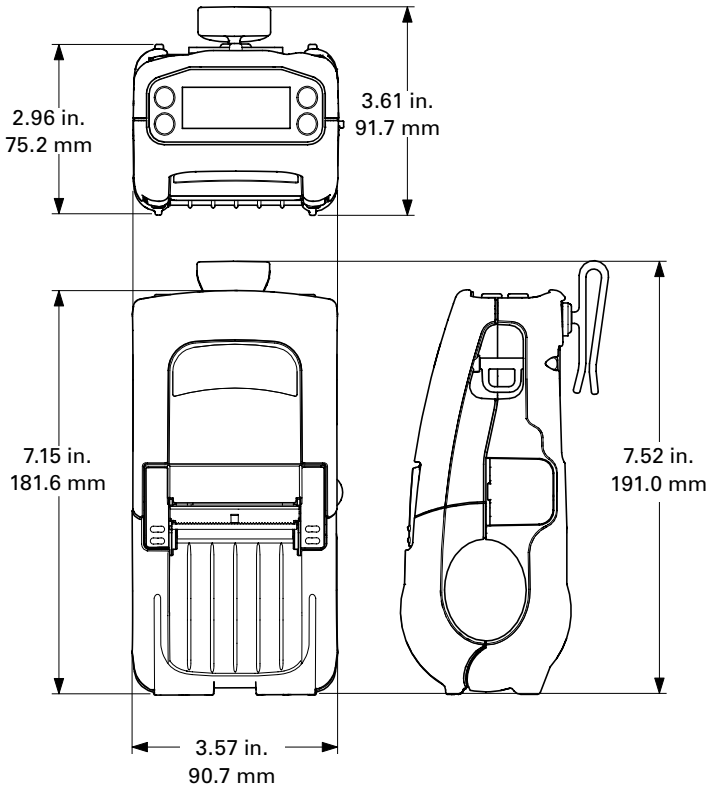

Figure 29: QL 220 Plus Overall Dimensions

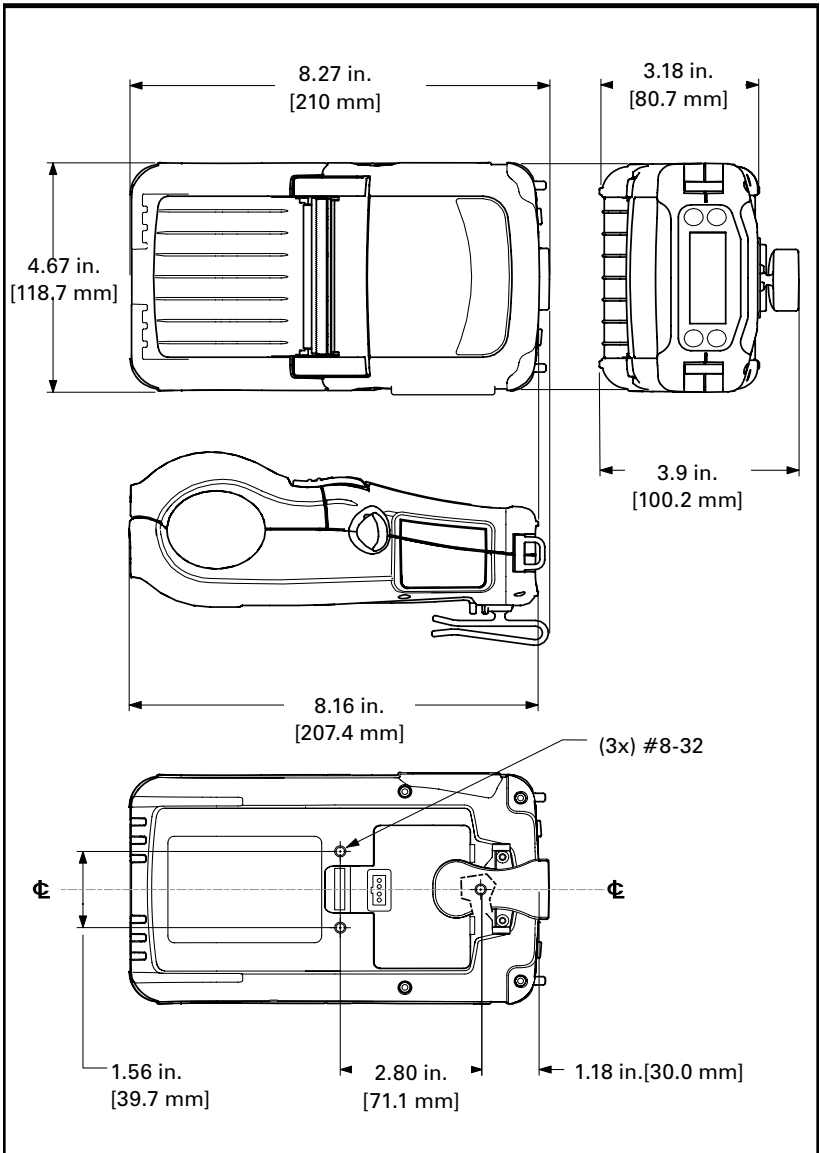

Figure 30: QL 320 Plus Overall Dimensions

1. Belt Clip must be removed to use all three mounting holes on the bottom of the QL 320 Plus.

continued

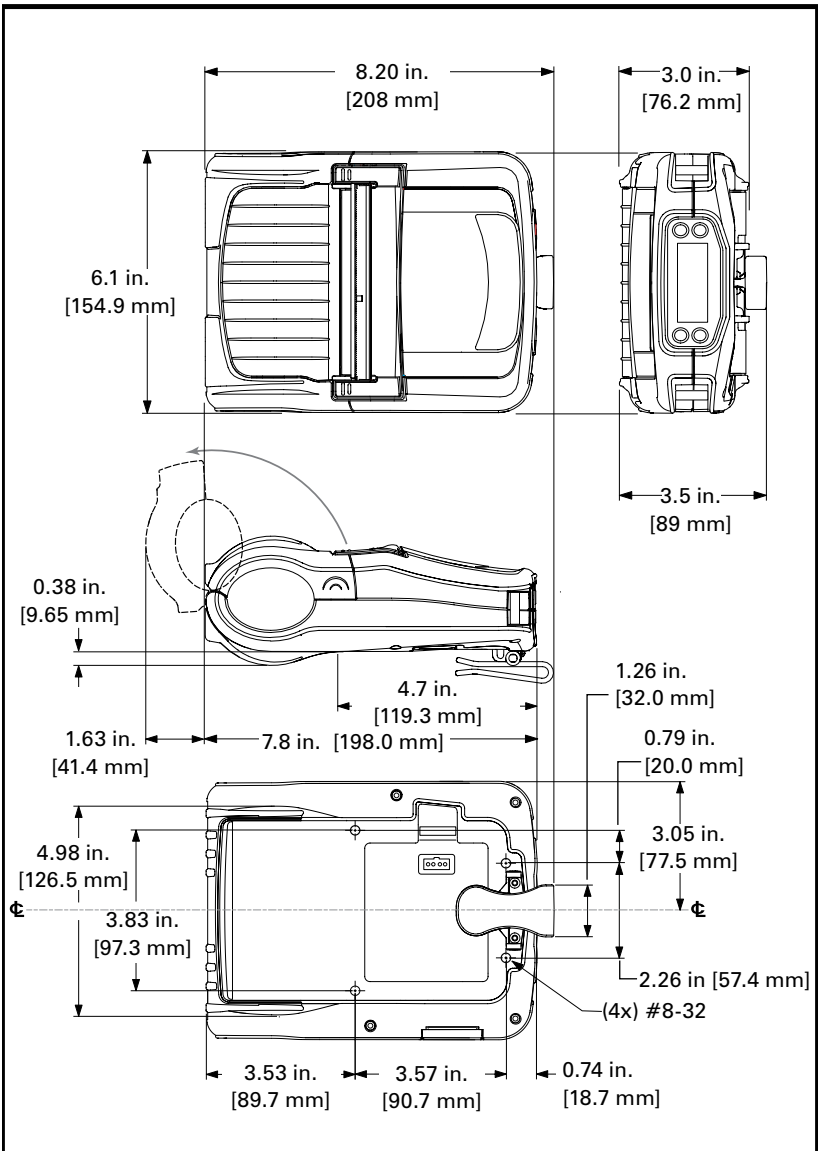

Figure 31: QL 420 Plus Overall Dimensions

QL Plus Series Accessories

Description	QL 220 Plus	QL 320 Plus	QL 420 Plus
Adjustable shoulder strap	•	•	•
Carrying Strap	•	•	•
Protective soft case	•	•	•
Extra battery packs	•	•	•
Desk Stand	•	•	•
Kickstand	•	•	•
Handi-Mount articulated arm and mounting plate			•
Model MM Q4 Vehicular Mount w/ external fanfold media storage			•
Model RCLI-DC Mobile Chargers-DC-DC run/charge units (input ranges from 12 to 60 VDC)	•	•	•
Model RCLI-AC- AC run/charge unit (100 to 240 VAC input)	•	•	•
Model LI72- Single Battery Charger (120-230 VAC input)	•	•	•
Model UCLI72-4 Quad Battery Charger (100-240 VAC input)	•	•	•
Battery Eliminator- (A.C. Run and Charge)	•	•	•



Refer to Appendix A for information on Data I/O Cables

For more details on available accessories, contact your authorized Zebra re-seller.

Appendix A

Interface Cables

RS232 Cables

Part Number BL11757-000; 8-Pin DIN to 9-Pin DB PC Cable (For Use With a Personal Computer)

This part is also available as a coiled cable under Part Number BL15063-1.

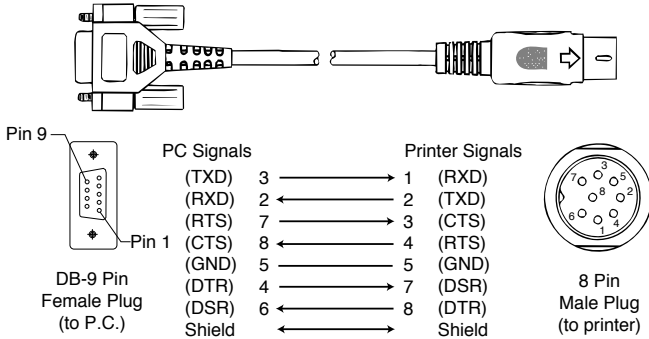

Part Number BL16555-1 (Molded Right Angle DIN Housing to 9-Pin DB)

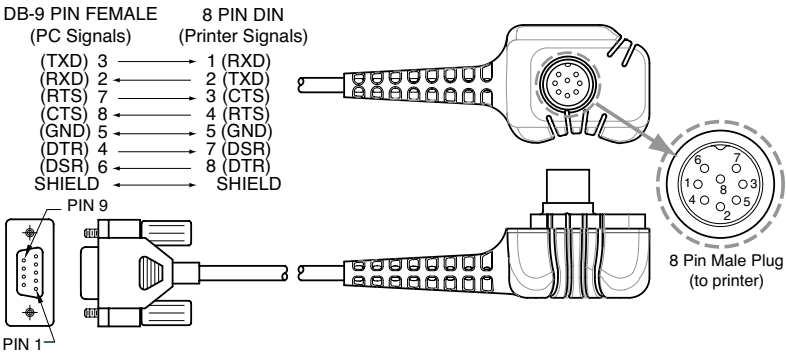

USB Cable

Part Number AT17010-1; USB A to USB Mini B Cable

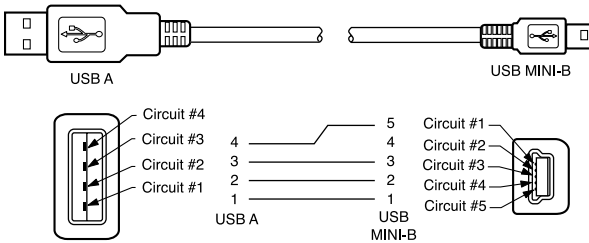

More Interface Cables



Contact the Factory or your Zebra Sales Representative for more information on interface cables to most major manufacturer's data terminals.

You may also visit the Zebra Web site at:
www.zebra.com/accessories **for a listing of interface cables for all series of Zebra mobile printers**

Appendix B

Media Supplies

To insure maximum printer life and consistent print quality and performance for your individual application, it is recommended that only media produced by Zebra be used.

Advantages include:

- Consistent quality and reliability of media products.
- Large range of stocked and standard formats.
- In-house custom format design service.
- Large production capacity which services the needs of many large and small media consumers including major retail chains world wide.
- Media products that meet or exceed industry standards.

For more information call Zebra Technologies Corporation at +1.866.230.9495 (U.S., Canada and Mexico) and ask to speak to a Media Sales Representative.

Appendix C

Maintenance Supplies

In addition to using quality media provided by Zebra, it is recommended that the printer be cleaned as prescribed in the maintenance section. The following items are available for this purpose:

- Cleaning Pen (10 pack), Reorder No. AN11209-1
- Cleaning Kit with Cleaning Pen, and Cotton Swabs, Reorder No. AT702-1

Appendix D

Product Support

When calling with a specific problem regarding your printer, please have the following information on hand:

- Model number/type (e.g. QL 420 Plus)
- Unit serial number (refer to figure on opposite page)
- Product Configuration Code (PCC) (refer to figure on following page))

In the Americas contact

Regional Headquarters	Technical Support	Customer Service Dept.
Zebra Technologies International, LLC 333 Corporate Woods Parkway Vernon Hills, Illinois 60061-3109 U.S.A T: +1 847 793 2600 Toll-free +1 800 423 0422 F: +1 847 913 8766	T: +1 847 913 2259 F: +1 847 913 2578 Hardware: ts1america@zebra.com Software: ts3america@zebra.com	For printers, parts, media, and ribbon, please call your distributor, or contact us. T: +1 877 275 9327 E: clientcare@zebra.com

In Europe, Africa, the Middle East, and India contact

Regional Headquarters	Technical Support	Internal Sales Dept.
Zebra Technologies Europe Limited Zebra House The Valley Centre, Gordon Road High Wycombe Buckinghamshire HP13 6EQ, UK T: +44 (0)1494 472872 F: +44 (0) 1494 450103	T: +44 (0) 1494 768298 F: +44 (0) 1494 768210 Germany: Tsgermany@zebra.com France: Tsfrence@zebra.com Spain/ Portugal: Tsspain@zebra.com All other areas: Tseurope@zebra.com	For printers, parts, media, and ribbon, please call your distributor, or contact us. T: +44 (0) 1494 768316 F: +44 (0) 1494 768244 E: cseurope@zebra.com

In the Asia Pacific region contact

Regional Headquarters	Technical Support	Customer Service
Zebra Technologies Asia Pacific, LLC Refer to "About Zebra/Contact Us" at www.zebra.com for complete contact information. T: +65 6858 0722 F: +65 6885 0838	T: +65 6858 0722 F: +65 6885 0838 E: (China) tschina@zebra.com All other areas: tsasiapacific@zebra.com	For printers, parts, media, and ribbon, please call your distributor, or contact us. T: +65 6858 0722 F: +65 6885 0836 E: (China) order-csr@zebra.com All other areas: csasiapacific@zebra.com

continued

Appendix D (continued)

Serial and PCC Number Locations for QL Plus Series Printers

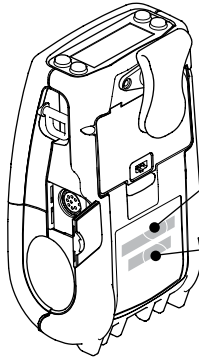

QL 220 PLUS

Serial Number
Barcode

PCC
Barcode

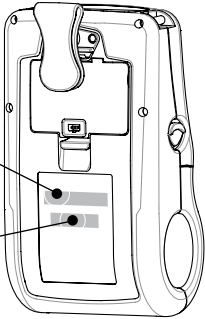

QL320 PLUS

Serial Number
Barcode

PCC
Barcode

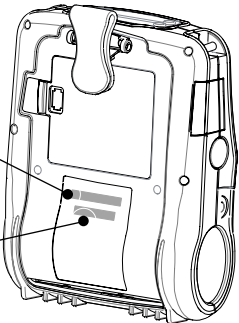

QL 420 PLUS

Appendix E

Battery Disposal



The EPA certified RBRC® Battery Recycling Seal on the Lithium-Ion (Li-Ion) battery supplied with your printer indicates Zebra Technologies Corporation is voluntarily participating in an industry program to collect and recycle these batteries at the end of their useful life, when taken out of service in the United States or Canada. The RBRC program provides a convenient alternative to placing used Li-Ion batteries into the trash or the municipal waste stream, which may be illegal in your area.



Important • When the battery is depleted, insulate the terminals with tape before disposal

Please call 1-800-8-BATTERY for information on Li-Ion battery recycling and disposal bans/restrictions in your area. Zebra Technologies Corporation's involvement in this program is part of our commitment to preserving our environment and conserving our natural resources.

Outside North America, please follow local battery recycling guidelines.

Product Disposal



The majority of this printer's components are recyclable.

Do not dispose of any printer components in unsorted municipal waste. Please dispose of the battery according to your local regulations, and recycle the other printer components according to your local standards.

For more information, please see our web site at: <http://www.zebra.com/environment>

Appendix F

Using zebra.com

The following examples use the search functions on Zebra's Web site for finding specific documents .

Example1: Find the Mobile Printer Wireless Configuration Guide.

Go to www.zebra.com/manuals.

Select as a manual type "Networking Manual" then click on "Submit".

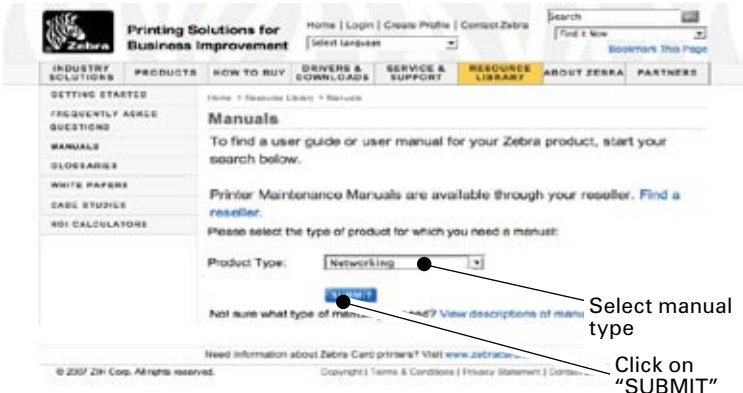

At the resulting screen, select Wireless Mobile as the networking type. Then select the desired language. (Best choices are "All" or "English")

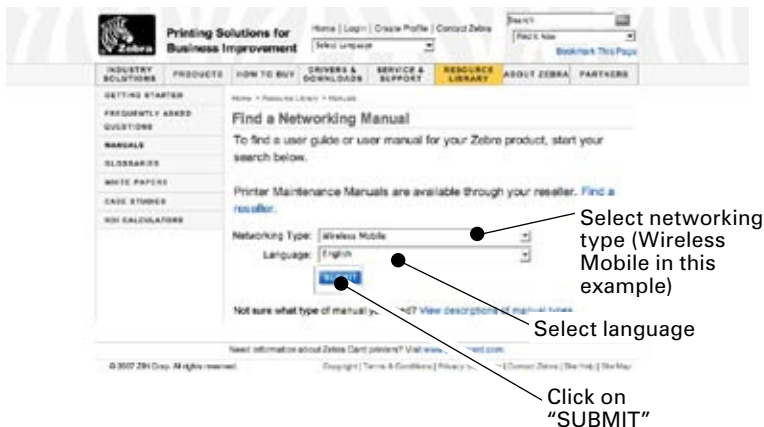

At the resulting screen, select "Zebra Mobile Printers - Wireless Configuration Guide" then click on "Download" to begin the download process.

Example 2: Find the Label Vista Download page:

Go to www.zebra.com/software and select “Label Vista”, then click “Submit”.

The screenshot shows the Zebra Software page. The navigation menu includes: INDUSTRY SOLUTIONS, PRODUCTS, HOW TO BUY, DRIVERS & DOWNLOADS, SERVICE & SUPPORT, RESOURCE LIBRARY, ABOUT ZEBRA, PARTNERS. The main content area is titled "Software" and includes a "Find Software for Your Printer" section with a "Select printer model" dropdown and a "SUBMIT" button. A sidebar on the left lists various product categories. A "FIND IT NOW" box on the right lists: Register software, Find printer drivers, Find printer utilities, Find firmware. A text box says "Select the 'Label Vista' demo" with an arrow pointing to the "Label Vista" link in the "Label Design Software" list. The footer contains copyright information and links for Terms & Conditions, Privacy Statement, Contact Zebra, Site Help, and Site Map.

At the resulting window select “Download a free Label Vista demo now”

Index

A

Accessories

- Belt clip 46
- Carrying Strap 50
- Desk Stand 48
- Kickstand 47
- list of 75
- Shoulder Strap 49
- using 46

B

- Battery, charging 12
- Battery, installing 11
- Battery life, tips for extending 51
- Battery Safety Guidelines 17
- Bluetooth™ Networking Overview 33
- Bluetooth Device Address (BDA) 33

C

- Charger, battery
 - LI72 Wall Chargers
 - Three-Wire Version 14
 - Two-Wire Version 13
 - UCL172-4 Quad Charger 15
 - charging times 16
 - front panel indicators 16
- Charger Safety Guidelines 17

Cleaning

- general instructions 52
- QL 220 Plus 52
- QL 320 Plus 54
- QL 420 Plus 56

Communications

- cable
 - strain relief for 30
- infrared (IR) 32
- RS232
 - Connector signals 70
 - with a cable 29
- USB
 - Connector signals 71
 - with a cable 29

- Communications diagnostics 62
- Configuration label, printing 62

D

- Damage, shipping 7
- Declaration of Conformity 802.11b (Compact Flash radio)

- EU countries 45
- EU countries
 - Bluetooth radio 36
 - Compact Flash 802.11b 39
 - Zebra 802.11b WLAN 41
 - Zebra 802.11g WLAN 42

L

- Label Vista 27,34
 - use in troubleshooting 62

M

- Manual
 - CPCL Programming 7,34
 - EPL Programming 35
 - ZPL II Programming 35
- Media, loading 18
 - fan-fold media 21
 - media spacer, use of 21
 - peel-off mode 22
 - QL 320 Plus 19
 - QL 420 Plus & QL 220 Plus 18
 - tear-off mode 22

O

- Operator Controls 23
 - Keypad 23
 - error indicator 24
 - power-on indicator 23
 - LCD Control Panel 25
 - functions displayed 27

P

- Platen
 - linerless 56
- Programming language
 - CPCL 7
 - EPL 35
 - ZPL II 35

Q

- QuickLink™ module 23,24

R

- Radio options. *See* Wireless communications
- Real Time Clock 67
- Regulatory Information
 - Bluetooth radio (ZBR3 & QL+ZBR4) 36
 - CF WLAN & Bluetooth Co-located radios 45
 - CF WLAN radio 38

PCMCIA WLAN radio, QL 320 Plus
42

Zebra 802.11b Radio 40

Zebra 802.11g Radio 42

S

Software 34

Specifications

Font/bar Code 69

Label 68

Memory/communications 67

Physical 71

printing 67

T

Troubleshooting

Communications Diagnostics Mode
62

Keypad control panel indicators 58

LCD control panel indicators 59

Troubleshooting tests 62

printing a configuration label 28,62

QL Plus configuration label ex-
ample 64

Troubleshooting Topics 60

W

Wireless communications

Bluetooth™ radio 33,34

dual radio configuration 34

Infrared (IrDA) 32

Local Area Network 23

Zebra 802.11b WLAN Radio 40

Zebra 802.11g WLAN Radio 42

WLAN Overview 34

Patent Numbers

This product and/or its use may be covered by one or more of the following US patents and corresponding international patents worldwide

D275,286	5,029,183	5,367,151	5,552,592	6,068,415
D347,021	5,047,617	5,372,439	5,570,123	6,068,415
D389,178	5,103,461	5,373,148	5,578,810	6,095,704
D430,199	5,113,445	5,378,882	5,589,680	6,109,801
D433,702	5,140,144	5,396,053	5,612,531	6,123,471
D549,768	5,132,709	5,396,055	5,642,666	6,147,767
3,964,673	5,142,550	5,399,846	5,657,066	6,151,037
4,019,676	5,149,950	5,408,081	5,768,991	6,201,255 B1
4,044,946	5,157,687	5,410,139	5,790,162	6,231,253 B1
4,360,798	5,168,148	5,410,140	5,791,796	6,261,009
4,369,361	5,168,149	5,412,198	5,806,993	6,261,013
4,387,297	5,180,904	5,415,482	5,813,343	6,267,521
4,460,120	5,229,591	5,418,812	5,816,718	6,270,072 B1
4,496,831	5,230,088	5,420,411	5,820,279	6,285,845 B1
4,593,186	5,235,167	5,436,440	5,848,848	6,292,595
4,607,156	5,243,655	5,444,231	5,860,753	6,296,032
4,673,805	5,247,162	5,449,891	5,872,585	6,364,550
4,736,095	5,250,791	5,449,893	5,874,980	6,379,058 B1
4,758,717	5,250,792	5,468,949	5,909,233	6,409,401 B1
4,816,660	5,262,627	5,479,000	5,976,720	6,411,397 B1
4,845,350	5,267,800	5,479,002	5,978,004	6,428,227 B2
4,896,026	5,280,163	5,479,441	5,995,128	6,530,705
4,897,532	5,280,164	5,486,057	5,997,193	6,540,122
4,923,281	5,280,498	5,503,483	6,004,053	6,607,316
4,933,538	5,304,786	5,504,322	6,010,257	6,609,844
4,992,717	5,304,788	5,528,621	6,020,906	6,874,958
5,015,833	5,321,246	5,532,469	6,034,708	6,899,477
5,017,765	5,335,170	5,543,610	6,036,383	
5,021,641	5,364,133	5,545,889	6,057,870	