



A760 Two-Color Thermal/Impact Hybrid Printer



User Guide



LogoEZ[®] colorization utility and Receiptware[®] marketing software information included.



Made under one or more of the following U.S. patents: 4886381, 5579043, 5613787, 5651624, 5713678, 5752779, 5789916, 5800080, 5879090, 5887999, 5975776, 6027266, 6085973, 6089450, 6129465, 6155483, 6404452, 6486902, 6504331, 5749277, 6722754, 6739773, 6784909. Other U.S. and international patents pending.



Federal Communications Commission (FCC) Radio Frequency Interference Statement Warning

Changes or modifications to this unit not expressly approved by the party responsible for compliance could void the user's authority to operate the equipment.

Note

This equipment has been tested and found to comply with the limits for a Class B digital device, pursuant to Part 15 of the FCC Rules. These limits are designed to provide reasonable protection against harmful interference when the equipment is operated in a commercial environment. This equipment generates, uses, and can radiate radio frequency energy and, if not installed and used in accordance with the instruction manual, may cause harmful interference to radio communications. Operation of this equipment in a residential area is likely to cause harmful interference in which case the user will be required to correct the interference at his own expense.

Information to the User

This equipment must be installed and used in strict accordance with the manufacturer's instructions. However, there is no guarantee that interference to radio communications will not occur in a particular commercial installation. If this equipment does cause interference, which can be determined by turning the equipment off and on, the user is encouraged to contact CognitiveTPG immediately.

CognitiveTPG is not responsible for any radio or television interference caused by unauthorized modification of this equipment or the substitution or attachment of connecting cables and equipment other than those specified by CognitiveTPG. The correction of interferences caused by such unauthorized modification, substitution or attachment will be the responsibility of the user.

In order to ensure compliance with the Product Safety, FCC and CE marking requirements, you must use the power supply, power cord, and interface cable which are sold for use with this product or which meet the following parameters:

Power Supply

UL Listed (QQGQ), Class 2 power supply with SELV (Secondary Extra Low Voltage), non-energy hazard output, limited energy source, input rated 100-240 Vac, 2.0 A, 50/60 Hz, output rated 24 Vdc, 2.5 A for 60 watt unit.

Use of this product with a power supply other than the CognitiveTPG power supply will require you to test the power supply and CognitiveTPG printer for FCC and CE mark certification.

Communication Interface Cable

A shielded (360 degree) interface cable must be used with this product. The shield must be connected to the frame or earth ground connection or earth ground reference at EACH end of the cable.

Use of a cable other than described here will require that you test the cable with the CognitiveTPG printer and your system for FCC and CE mark certification.

Power Cord

A UL listed, detachable power cord must be used. For applications where the power supply module may be mounted on the floor, a power cord with Type SJT marking must be used. For applications outside the US, power cords which meet the particular country's certification and application requirements should be used.

Use of a power cord other than described here may result in a violation of safety certifications which are in force in the country of use.

Industry Canada (IC) Radio Frequency Interference Statement

This Class B digital apparatus meets all requirements of the Canadian Interference-Causing Equipment Regulations.

Cet appareil numérique de la classe B respecte toutes les exigences du Règlement sur le matériel brouilleur du Canada.

Voluntary Control Council for Interference (VCCI) Radio Frequency Interference Statement

This is a Class B product based on the standard of the voluntary Control Council for Interference by Information Technology Equipment (VCCI). If this equipment is used in a domestic environment, radio disturbance may arise. When such trouble occurs, the user may be required to take corrective actions.

Disclaimer

Information in this document is subject to change without notice. Consult your CognitiveTPG sales representative for information that is applicable and current. CognitiveTPG reserves the right to improve products as new technology, components, software, and firmware become available.

No part of this document may be reproduced, transmitted, or translated in any form or by any means, electronic or mechanical, for any purpose without the express written permission of CognitiveTPG.

Copyright

Copyright © 2012 CognitiveTPG, LLC, 950 Danby Road, Ithaca, New York 14850, USA. All rights reserved. Printed in USA. Property of CognitiveTPG, LLC.

Trademarks

CognitiveTPG™ is a trademark of CognitiveTPG, LLC.

Microsoft, Windows are registered Trademarks of Microsoft Corporation in the U.S.A. and/or other countries.

Inside Out Networks, Inside Out, EPIC, and Edgeport are trademarks of Inside Out Networks.

All other trademarks and registered trademarks are the property of their respective holders.

Website: <http://www.cognitivetpg.com>

Contents

Chapter 1: About this Guide	5
How to use this guide	5
Where to find advanced technical information	5
Download manuals.....	5
Support	5
Chapter 2: About the Printer	7
Introducing the A760 ColorPOS® printer	7
About the Universal Serial Bus	8
Advantages of USB connections	8
Advantages of the CognitiveTPG USB solution	8
About the Ethernet Interface Option	9
Printer controls.....	10
Available printer configurations.....	11
Printer configuration identification	11
Communication interfaces	11
Standard features	11
Options	13
Chapter 3: Setting up the Printer	14
Unpack the printer	14
Check the packing list.....	14
Remove the packing restraints	15
Load or change the receipt paper.....	16
Installing or replacing the ribbon cassette	17
Replacing a used ribbon cassette	17
Installing a new ribbon cassette	17
Choose a location.....	18
Connect the cables	19
Cash drawer cables	19
Communication cables	20
If installing the RS-232C communication cable:	20
If installing the USB communication cable:.....	20
If installing the Powered USB cable:	20
If installing the Ethernet communication cable:.....	21
If installing the IEEE 1284 Parallel communication cable:	21
Power supply cable	21
Cable routing.....	22
Test the printer	22

Chapter 4: Using the Printer	25
Printing on forms or checks	25
Verifying and validating checks.....	26
Printer configurations.....	27
Ethernet option	28
Configuring the printer	29
Communication interface.....	30
RS-232C serial interface settings.....	30
Parallel communication	30
Ethernet settings	30
Diagnostic modes	31
Enable or disable data scope mode.....	31
Enable or disable receipt test mode	32
Enable or disable slip test mode.....	32
Enable or disable MICR test mode	32
Setting the printer emulations	33
Printer settings and functions	34
Select the emulation/software options sub-menu to set:.....	34
Select the hardware options sub-menu to set:	35
Preventing overheating of the printhead.....	36
Troubleshooting the printer	37
Printer will not print.....	38
On-line, paper status, error LED flashes	39
Slip-in LED does not light (rectangular green LED on slip table) ..	39
Poor forms print quality	40
Poor receipt print quality	40
Slip station and MICR problems.....	41
Knife does not operate	42
Other conditions	42
Contacting a service representative.....	42
Returning a printer	43
Chapter 5: Paper and supplies	45
Ordering from CognitiveTPG	45
Ordering thermal paper	45
Thermal paper specifications.....	45
Manufacturers	45
Ordering miscellaneous supplies	47
Cash drawers	47
Power supply and power cords	47
MICR reader – additional information	50
Ordering ribbon cassettes.....	50
Ordering extended slip tables	50
Documentation, LogoEZ® utility, and Receiptware® marketing software.....	50

Chapter 1: About this Guide

How to use this guide

The guide is designed to help you find the information you need quickly and easily, whether you are installing, servicing, or making adjustments to a CognitiveTPG printer. The chapter headings are self-explanatory, and the index at the back can also point you in the right direction.

For basic printer setup, refer to *Chapter 3: Setting up the Printer*. This section has been written under the assumption that the printer will arrive pre-configured. For instructions on checking the configuration or reconfiguring the printer, look in *Chapter 4: Using the Printer*.

Having problems? Check the [troubleshooting section in the back of Chapter 4](#).

Need paper specs? Look in *Chapter 5: Paper and Supplies*.

Where to find advanced technical information

Since CognitiveTPG printers are shipped pre-configured and have been designed to operate with no maintenance, this guide provides only essential technical and configuration information. CognitiveTPG also has a programming supplement for this printer with more detailed discussion of programming capabilities. The **A760 Programming Supplement** has been developed as a companion to the **User Guide** and includes additional programming information. The **A760 Service Guide** is available to qualified service technicians who have been certified by CognitiveTPG to perform advanced procedures.

Because of the printer's wide array of printing capabilities, you may prefer to [contact CognitiveTPG support](#) for more assistance.

Download manuals

The **A760 Setup Guide**, **A760 User Guide**, and **A760 Programming Supplement** can be downloaded from the CognitiveTPG Web site in .pdf format: <http://www.cognitivetpg.com>, in the "Support" window.

Support

For more advanced procedures and troubleshooting, you may need to refer to the printer's programming or service guides or speak to CognitiveTPG technical support. Your CognitiveTPG representative is also able to provide you with necessary information.

Additional information about CognitiveTPG's products and services is posted on the CognitiveTPG Web site, at <http://www.cognitivetpg.com>. The Web site can also direct you to service and support within your area, or e-mail: support@cognitivetpg.com.

Chapter 2: About the Printer

Introducing the A760 ColorPOS® printer

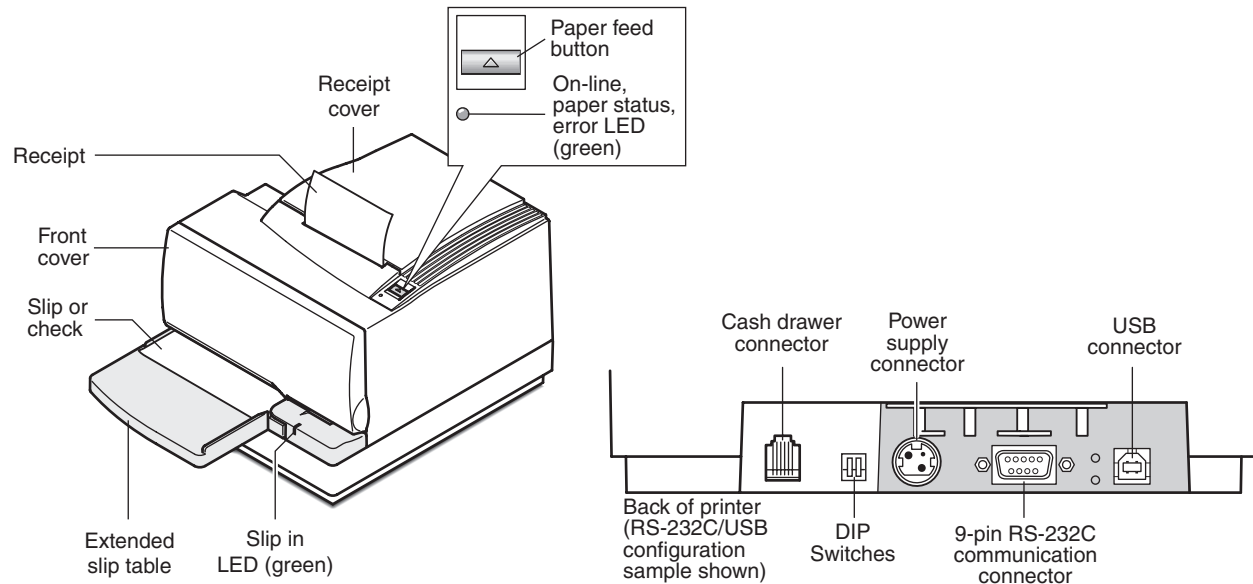

The A760 ColorPOS® two-color printer is an extremely fast, quiet, and reliable point-of-sale (POS) printer. It consists of two specialized printers in one compact package: a two-color thermal printer on top that prints receipts, and an impact slip printer in front to print on forms and checks that you insert. The thermal printer is optimized for ease-of-use in busy environments. There is no ribbon or ink cartridge to change, and you load the paper by simply dropping in a new roll. The impact printer provides the power and flexibility necessary to print on checks or multi-part forms up to five plies, in a wide variety of sizes and orientations.

The A760 easily fits in anywhere. It connects to any host computer that uses the standard 9-pin or 25-pin RS-232C or USB (Universal Serial Bus) interface. An IEEE 1284 parallel and an Ethernet interface are also available.

The printer's standard command set allows it to work with software written for CognitiveTPG, or other compliant printers. A variety of sensors enable the printer to communicate its status, and the printer's journal is kept electronically by the host computer.

The Magnetic Ink Character Recognition (MICR) option enables the printer to read the special codes printed on checks and send this information to the host computer to verify the check. This section describes the printer's features and options in more detail.

This printer is compatible with CognitiveTPG's LogoEZ® logo and colorization utility, and with CognitiveTPG's Receiptware marketing software. See [Programming Supplement](#) or go to the website www.cognitivetpg.com for more information on obtaining and using these options. (ColorPOS® and LogoEZ® patent pending.)

About the Universal Serial Bus

The Universal Serial Bus (USB) is a peripheral bus for personal computers that was first released in January 1996. Since that time, virtually all Intel Architecture personal computers have the hardware to support USB, and a large number of computers exist that have both the hardware and software support required to interface with USB peripherals.

Advantages of USB connections

USB has a number of advantages over Application Compatible Escape Commands connection schemes (e.g., serial RS-232C, parallel IEEE 1284). These advantages include:

- High Speed: up to 12 MB/second for high-speed devices.
- Plug and Play: Devices are automatically recognized and configured at installation.
- Hot plug: Bus supports installation and removal of devices with the power applied.
- Up to 127 devices: One host can support up to 127 devices with the use of hubs.
- “Free ports”: Most PC architecture machines contain two USB ports in the base hardware.

These advantages have become attractive to the POS industry for a couple of reasons.

Additional POS devices. Some POS systems are required to host more peripherals than can be supported by two RS-232C ports typical in a platform. With the addition of one (or two) USB connectors, the platform can now support the additional devices that had previously required a serial port expander card.

Higher bandwidths. New devices coming into use have bandwidth requirements that are higher than the bandwidth that can be supported on Application Compatible Escape Commands interfaces. These devices include image scanners and printers. As the speed and capability of POS printers increases, the performance of the printer in an application can become limited by the speed of the communications interface. USB provides ample bandwidth to support current and future POS printer requirements.

Advantages of the CognitiveTPG USB solution

CognitiveTPG provides two USB solutions. If your application is designed to talk to the printer as an RS-232C device, we offer an **RS-232C Emulation USB (Comm Class) Driver**. If your application is capable of talking to a USB device, we offer a **Printer Class USB Driver**.

The RS-232C Emulation USB (Comm Class) and the Printer Class USB drivers are compatible with PCs that run Windows XP/Vista/7/8.

About the Ethernet Interface Option

Ethernet is a base band Local Area Network used to connect multiple personal computers and peripherals (stations) over twisted pairs of wire or co-axial cable. It closely resembles IEEE 802.3 specification jointly developed by Digital Equipment, Intel, and Xerox. Originally invented by Xerox, Ethernet is a carrier sense, multiple access, collision detect network (CSMA/CD). It is designed to serve in networks with sporadic, occasionally heavy traffic environments.

CognitiveTPG's POS implementation is **10baseT**. This configuration of speed, cable, and connector design allows installation and reconfiguration simplicity. Print speed may be reduced during heavy network traffic conditions. Some **100baseT** (100Mbps) environments can be supported if the network has implemented auto-negotiation features that automatically down switch to a 10Mbps data rates, upon detection of slower attached stations.

Summary of Design Features

- Ethernet Type 10baseT
- Speed 10Mb/sec
- Cable 2 twisted pairs. Maximum cable segment length between stations is 100m.
- Connector Shielded RJ-45 communications connector will provide peripheral shielding capability for twisted pair cables.
- Network Status LEDs Transmit active, Receive active, Link integrity, and Board select
- MAC address configuration Stored in EEROM
- IP address configuration Specify IP, BOOTP
- Protocol Support Raw TCP, LP, TELNET with binary and timing mark support
- Client Support
 - Windows XP, Vista, 7, 8 with standard serial emulation port
 - Windows XP, Vista, 7, 8 with TCP/IP implemented by customer
 - Windows XP, Vista, 7, 8 with standard windows drivers
 - UNIX with TCP/IP implemented by customer

See “If installing the Ethernet communication cable” section, page 23 this manual and “Ethernet terminology and setup” in the [A760 User programming supplement](#).

Printer controls

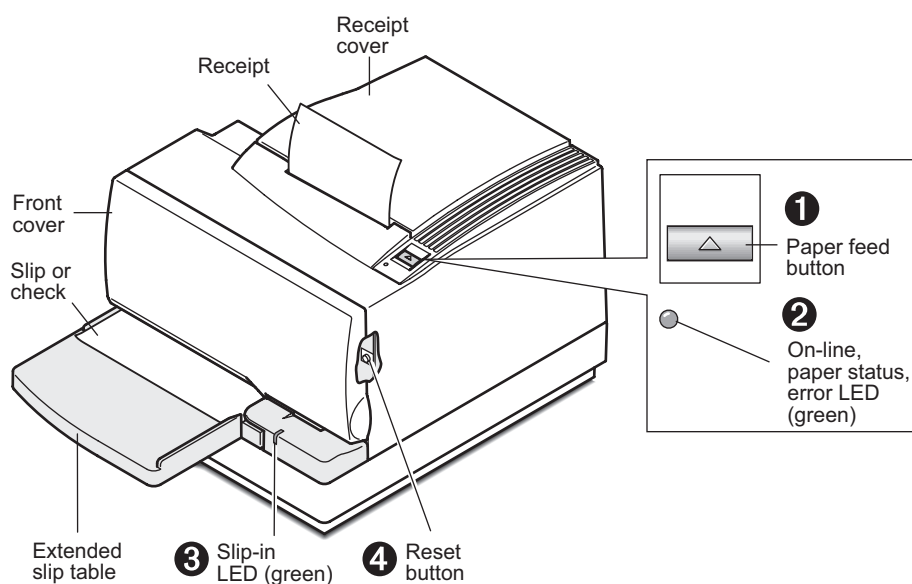

The printer has the following controls:

- 1 The paper feed button advances the receipt paper.
- 2 The on-line, paper status, error LED shows the printer status by shining or flashing.
- 3 The slip-in LED indicates that a form is inserted properly.
- 4 The reset button clears the printer's memory or begins special modes.

The printer also indicates its status when it is first turned on, or after it has been reset, by beeping. A single beep indicates the printer has successfully completed its startup routine. If the printer beeps in a single, double, or triple pattern at first power on, please call your service representative.

Available printer configurations

There are several configurations of the printer, depending on the combination of desired options.

Printer configuration identification

See the sample below to determine the printer configuration. The printer configuration identification (model ID) is located on the model label attached to the right side of the printer. The model ID description is shown below.

Communication interfaces

- RS-232C serial interface (9-pin)
- RS-232C serial interface (25-pin)
- Combination RS-232C (9-pin) and USB
- Powered USB
- IEEE 1284 parallel interface
- Ethernet interface

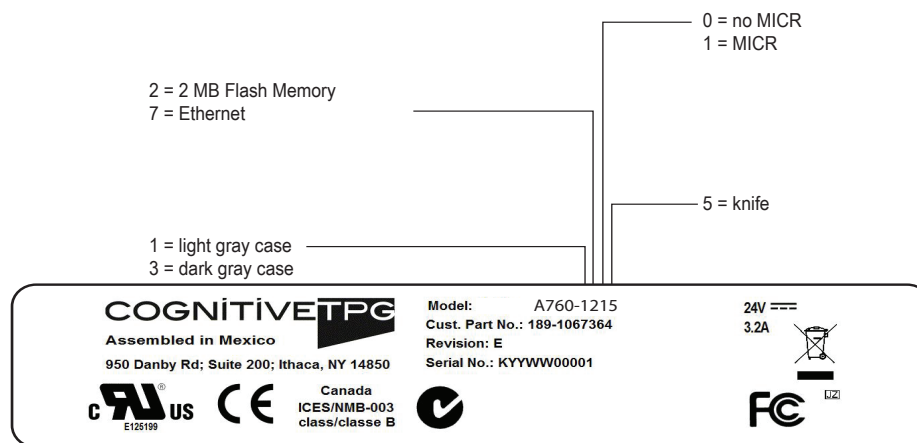

Standard features

Connectivity features

Industry standard 9-pin and 25-pin RS-232C, USB (Universal Serial Bus), IEEE 1284 parallel or Ethernet interfaces are available options for communication with the host computer.

These are provided via option boards: 9-pin RS-232C only, 25-pin RS-232C only, Powered USB only, a combined USB/9-pin RS-232C board, an IEEE 1284 parallel board or an Ethernet board.

Cash drawer kickout connector and software support for up to two cash drawers.

Advanced interface design

Sensors detect whether any of the covers are open, the paper is low in the receipt printer, or the paper is positioned properly in the slip printer.

Software-controlled audible tone for various alerts.

Online configuration menu—the printer guides the user through its configuration settings by printing instructions and a menu on receipt paper.

Electronics and firmware

Industry-standard command set makes the printer compatible with existing software, yet enables new features.

Remote diagnostics capability tracks important printer data.

continued...

Electronics and firmware continued...	<p>2MB flash memory standard available memory for multiple logos, graphics, user-defined character set, and user data storage.</p> <p>16-bit electronics architecture.</p> <p>Communication rate up to 115,200 baud.</p> <p>Flash download mode lets the user upgrade the printer's firmware.</p>
Thermal receipt printer	<p>Extremely fast and quiet two-color thermal printhead.</p> <p>No ribbon or ink cartridge to change.</p> <p>Drop-in paper loading. Paper type selection through command "Set paper type" (1D 81 m n) or configuration menu.</p> <p>Double high, double wide, bold, inverse, underlined, superscript and subscript, italics, scalable and rotated print modes.</p> <p>Resident character sets: Code Pages 437 (US), 850 (Multilingual), 737 (Greek), 852 (Slavic), 858 (with Euro symbol), 857 (Turkish), 860 (Portuguese), 862 (Hebrew), 863 (French-Canadian), 865 (Nordic) 866 (Cyrillic), 1251 (Cyrillic), 1252 (Windows Latin 1) and 1255 (Hebrew).</p> <p>Prints standard bar codes: Code 39, UPC-A, UPC-E, JAN8 (EAN), JAN13 (EAN), Interleaved 2 of 5, Codabar, Code 93, Code 128, EAN 128, GS1 Databar, QR Code and PDF-417 two-dimensional code. Also prints "ladder" bar codes.</p> <p>Host-selectable 44 or 56 columns on 80 mm wide "POS grade" monochrome or two-color thermal paper. (See page 45 for paper manufacturers.)</p> <p>8 dots/mm print resolution.</p> <p>Up to 53.3 lines-per-second (180 mm/second) throughput print speed (monochrome); up to 29.3 line-per-second (100 mm/second) throughput print speed (two-color).</p> <p>Standard receipt cutter.</p> <p>LogoEZ[™] utility and Receiptware software compatible (see options next page).</p>
Impact slip printer	<p>Bi-directional impact printhead designed for a very long life.</p> <p>Snap-on ribbon cassette.</p> <p>Prints on forms up to five plies.</p> <p>Horizontal flatbed slip table with an optional extension (which is standard with the MICR check reader option).</p> <p>Form insertion flexibility: insert forms in front or from the side.</p> <p>Form alignment sensors and LED indicator.</p> <p>Resident character sets: Code Pages 437 (US), 850 (Multilingual), 737 (Greek), 852 (Slavic), 858 (with Euro symbol), 857 (Turkish), 860 (Portuguese), 862 (Hebrew), 863 (French-Canadian), 865 (Nordic) 866 (Cyrillic), 1251 (Cyrillic), 1252 (Windows Latin 1) and 1255 (Hebrew).</p> <p>Prints standard linear bar codes: Code 39, UPC-A, UPC-E, JAN8 (EAN), JAN13 (EAN), Interleaved 2 of 5, Codabar, Code 93, Code 128, and EAN 128.</p> <p>Double wide and rotated print modes; a double strike print mode improves contrast.</p> <p>Software selectable pitch: either standard (13.9 characters per inch, 66 columns) or compressed (17.1 characters per inch, 80 columns).</p> <p>4.8 lines-per-second (16 mm/second) print speed.</p> <p>Optional check handling features (see "Impact slip printer options" on the next page).</p>

Exceptions	<p><i>Print speed and throughput will decline when:</i></p> <p>Temperature is less than 25°C.</p> <p>Energy setting is greater than 100%.</p> <p>Dot coverage is greater than 25% or the format contains solid horizontal lines.</p> <p>The printer is waiting for data or on an Ethernet interface network traffic is heavy.</p> <p>Power setting is equal to 48 Watts.</p>
-------------------	---

Options

Connectivity	<p>Six standard plug-in printed circuit boards are available depending on the communication interface required. Interfaces with 9-pin or 25-pin RS-232C only, Powered USB only, a combination 9-pin RS-232C and USB, an IEEE 1284 parallel or an Ethernet board can be provided.</p> <p>Communication cables are available for the RS-232C interfaces (see below).</p> <p>3-pin to 6-pin power connection adapter to allow previous version power supplies (or terminal cables) to be connected to the A760.</p>
Thermal receipt printer	The optional receipt cutter.
Impact slip printer	<p>The slip table is available in either standard or an extended size. An extended slip table is standard with the MICR check reader.</p> <p>The Magnetic Ink Character Recognition (MICR) check reader is built into the slip station. It reads checks that use standard E-13B or CMC-7 MICR fonts.</p>
Electronics and firmware	Communication cables: RS-232C (9-pin or 25-pin) available
LogoEZ® utility	<p>Logo and colorization utility is available from your CognitiveTPG representative or downloadable from www.cognitivetpg.com.</p> <p>Provides a basic two-color and logo format for receipts.</p>
Receiptware® software	<p>Receiptware marketing software is available from CognitiveTPG representative or downloadable from www.cognitivetpg.com.</p> <p>Provides ability to customize receipts with logos, watermarks, highlighted text and graphics.</p>

Chapter 3: Setting up the Printer

Unpack the printer

Check the packing list

Save all packing materials in case you need to repack the printer for shipping or storage. Before installation, check that all the items on this list have been shipped (printers shipped in bulk may not include all these items):

- Printer (enclosed in a plastic bag with foam pack)
- Test printout protecting the printhead (inside receipt bucket)
- Cardboard support for cantilever (on slip table)
- Foam restraint for carriage (behind front cover)
- Power supply with cable connecting to printer and power supply cord connecting to power outlet (only if ordered with the printer)
- Ribbon cassette
- A760 ColorPOS® Two-Color Thermal Receipt and Impact Slip Printer: Setup Guide
- RS-232C Communication cable from host to printer is available if ordered with printer. Other cables must be obtained by the user.

To report any missing materials, or to report a printer that was damaged during shipping, call your supplier or call a CognitiveTPG representative at:

Sales/General Information	1(800)732-8950
Service/Operational Questions	1(800)732-8950, option 4

– or –

You can visit our website at <http://www.cognitivetpg.com> and contact us by email.

- 1 Click on “Contact Us” on main page.
- 2 Fill in form information on window that comes up.
- 3 Send.

Remove the packing restraints

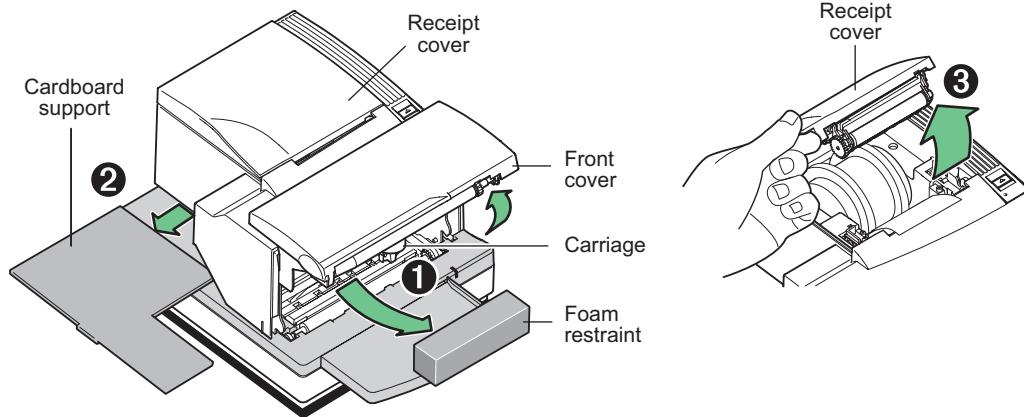

- 1 Open the front cover, remove the foam restraint holding the carriage (1).
- 2 Remove the cardboard support (2) from the slip path.
- 3 Open the receipt cover (3).
- 4 Remove the test printout. It is recommended that you retain the test printout until the printer is successfully installed

Continue to “Load or change the receipt paper on next page...”

Load or change the receipt paper

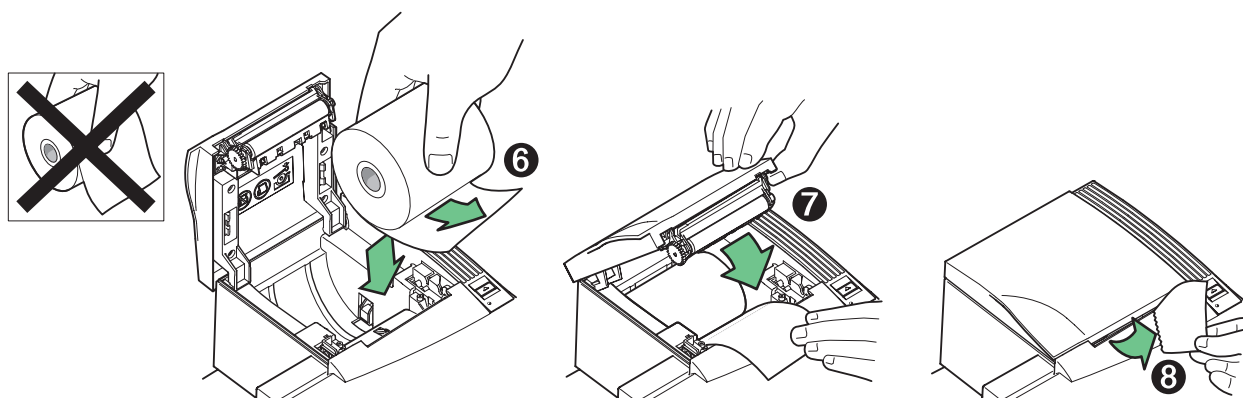

Change the paper when either a colored stripe appears on the receipt paper or the printer's on-line, paper status, error LED slowly flashes (indicating that 15 ± 10 feet of paper remains on the roll). Change the paper as soon as possible to avoid running out of paper part way through a transaction.

If the on-line, paper status, error LED blinks fast, the paper is out. Change the paper immediately or data may be lost. The printer will not operate without paper, but it may continue to accept data into memory from the host computer. Because the printer cannot print any transactions, this data in memory may be lost.

If changing the type of paper being used (monochrome vs. two-color ColorPOS® version or manufacturer type), you will need to send the "Set paper type" (1D 81 *m n*) command. Use the "Set paper type" (description found in the *Programming Supplement*) or selection in the configuration menu. (See page 32 for how to enter the configuration menu and page 48 for types of paper available.)

- 1 Open the receipt cover and remove the used roll (if present).
- 2 Tear off the end of the new roll so that the edge is loose.
- 3 Place the roll into the paper bucket with the paper unrolling from the bottom of the roll (6), and with a few inches of paper extending over the cabinet front.
Note: Paper must unroll from the bottom of the roll to insure that the image will print.
- 4 Close the receipt cover while holding the paper over the front of the cabinet (7).
- 5 Remove the excess paper by tearing it against the tear-off blade (8).
- 6 Press the paper feed button to advance the paper if necessary.

Installing or replacing the ribbon cassette

Change the impact printer's ribbon cassette if it is printing lightly or produces marks, lines or other inconsistent printing on the receipt.

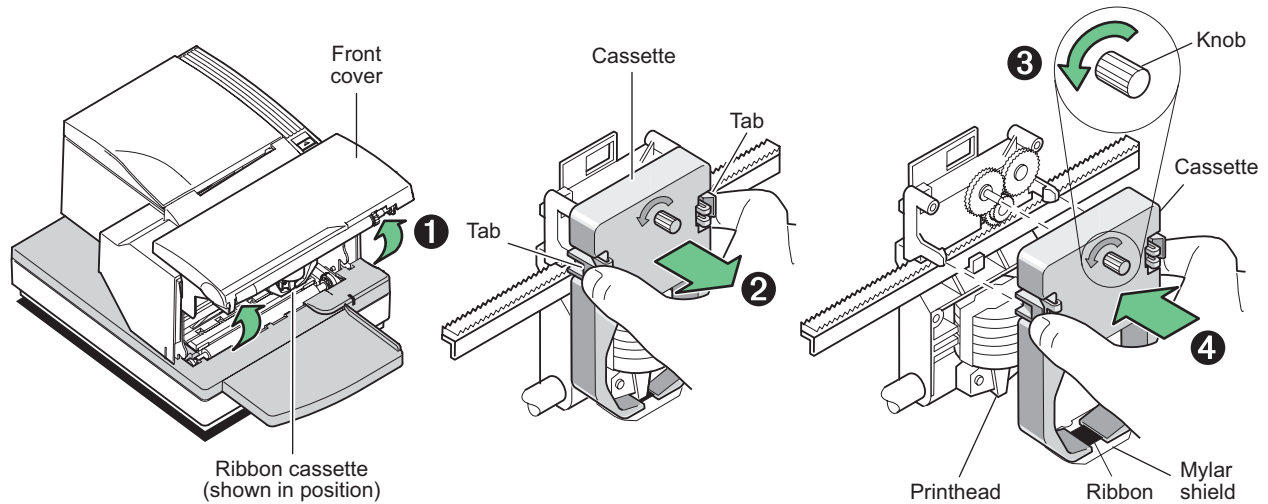

Replacing a used ribbon cassette

- 1 Open the front cover (1) by grasping the cover on each side at the bottom and swing up.
- 2 Pinch in tabs (2) of the old ribbon cassette and pull to remove it.
- 3 Continue to "Installing a new ribbon cassette" step 2.

Installing a new ribbon cassette

- 1 Open the front cover (1) by grasping the cover on each side at the bottom and swing up.
- 2 Unwrap the new ribbon cassette and tighten the ribbon by turning the knob (3) on the cassette in the direction of the arrow.

Caution: DO NOT remove the mylar shield.

- 3 Position the ribbon cassette onto the carriage, as shown (4), making sure the ribbon is underneath the printhead.
- 4 Snap the cassette into place and snap the front cover closed.

Choose a location

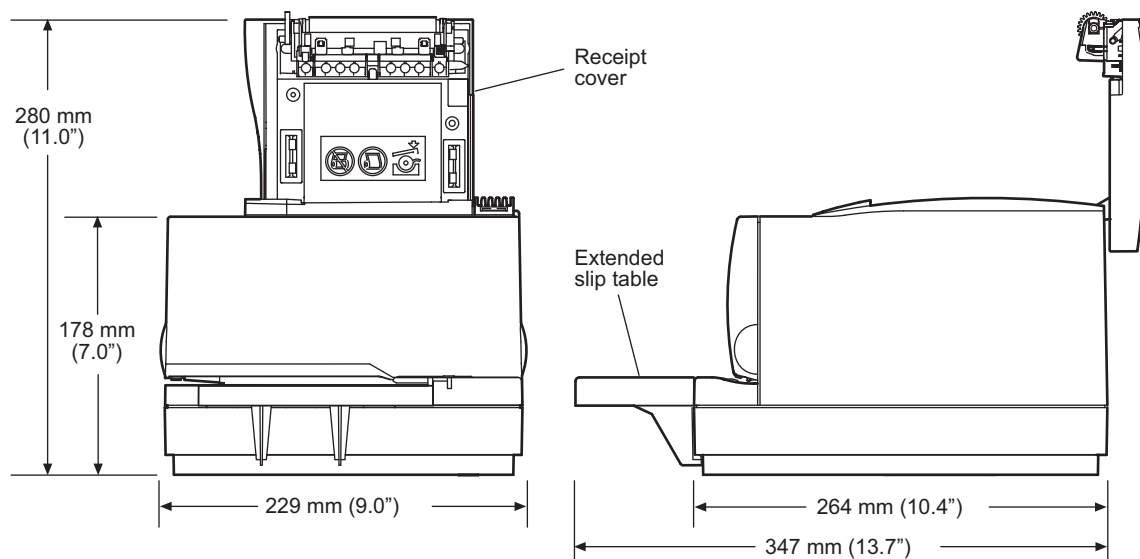

The A760 printer takes up relatively little counter space and may be set on or near the host computer. With the RS-232C interface, you can place the printer up to 50 feet (with the USB interface up to 15 feet) from the host computer and power supply.

Place the printer on a level surface, and make sure there is enough room to open the receipt cover to change the paper and to open the front cover to change the impact printer's ribbon cassette. Leave several inches around the printer for connecting and accessing the cables.

If the printer has an optional Magnetic Ink Character Recognition (MICR) check reader installed, you may need to make additional adjustments to the printer's location.

Because devices such as CRT monitors or large metal surfaces affect the printer's magnetic field, they can cause intermittent check reading errors.

Connect the cables

Cable connections are made at the back of the printer.

Caution: Connect the cables to the printer before applying power. The host computer should always be turned off before connecting communication cables.

Warning! When instructed to connect the USB cable from the host to the printer, be careful to plug it into the USB board connector only (A). **Do not insert the USB cable into the Cash Drawer connector (B)** on the left back of the printer. Damage to the printer could occur. If you are not sure of your printer configuration, contact CognitiveTPG before proceeding.

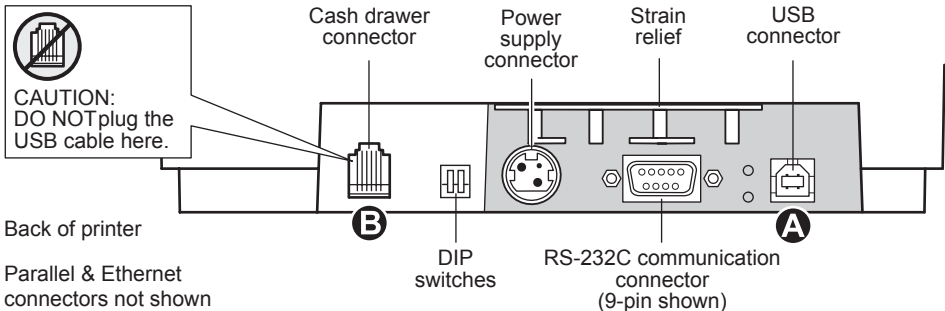

Note: Connector panel varies with printer configuration (parallel and ethernet connector versions not shown.)

Cash drawer cables

The cash drawer cable connects the printer to one or two cash drawers.

Warning! Be careful to connect correct cable into printer cash drawer connector.

- 1 Plug the cable into the cash drawer connector (standard phone jack) located at the rear of the printer.

Note: If your system has two cash drawers, attach a Y-cable to the printer's cash drawer connector as shown.

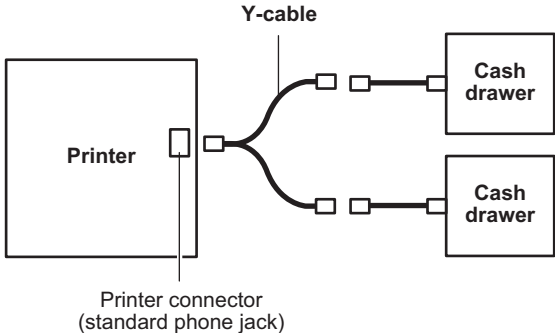

Communication cables

The communication cable connects the printer to the host computer.

If installing the RS-232C communication cable:

RS-232C 9-pin communication connector panel

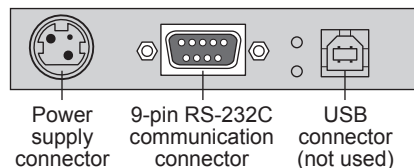

RS-232C 25-pin or parallel communication connector panel

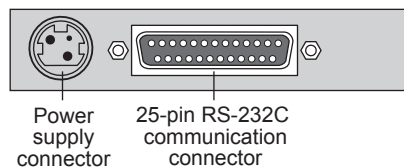

- 1 Turn off the host computer.
- 2 Plug the communication cable into the connector at the bottom back of the printer.
- 3 Secure the connector by tightening the screws.
- 4 Connect the cable to the host computer.
- 5 Turn host computer on.

If installing the USB communication cable:

USB communication connector panel

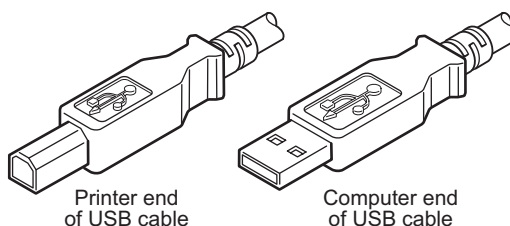
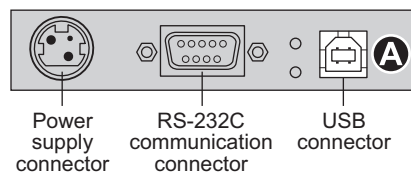

- 1 Host computer can remain on.
- 2 Plug the printer end of the USB cable into the USB connector port on the printer (A).
- 3 Route the cable from the printer as shown on the following page to provide strain relief.
- 4 Plug the computer end of the USB cable into the computer. Make sure the USB symbol on the connector is facing up when you plug it in.

After you have completed setting up the printer, you can install the USB driver onto the host computer.

Download the [USB driver](http://www.cognitivetpg.com) to the host computer from the *Downloads* section of the CognitiveTPG website at <http://www.cognitivetpg.com>.

If installing the Powered USB cable:

Powered USB communication connector panel

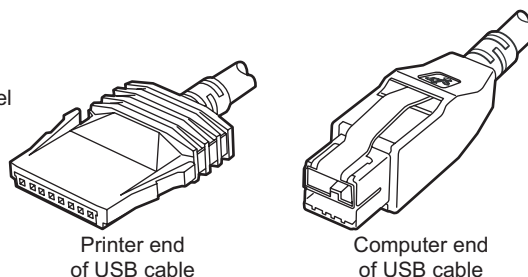
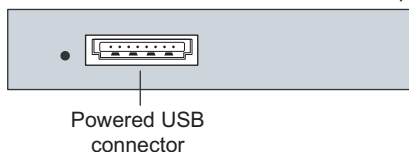

- 1 Be sure the host computer is powered off.
- 2 Plug the printer end of the USB cable into the USB connector port on the printer.
- 3 Route the cable from the printer as shown on the following page to provide strain relief.
- 4 Plug the computer end of the USB cable into the computer.

If installing the Ethernet communication cable:

Ethernet communication connector panel

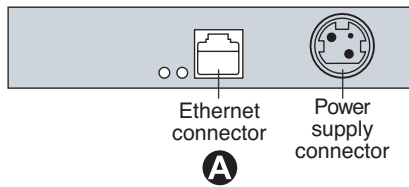

- 1 Host computer can remain on.
- 2 Plug the printer end of the Ethernet cable into the Ethernet connector port on the printer (A). Make sure the connector snaps firmly in place.
- 3 Plug the computer end of the Ethernet cable into the Ethernet port of the computer. Make sure the connector snaps firmly in place.
- 4 After you have connected the printer, you must set the printer internal parameters for Ethernet operation. See “Ethernet terminology and setup”, in the [A760 Programming supplement](#).

If installing the IEEE 1284 Parallel communication cable:

IEEE parallel communication connector panel

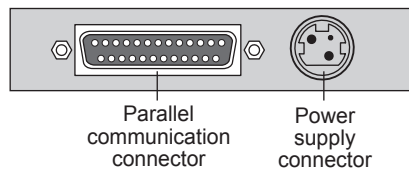

- 1 Turn off the host computer.
- 2 Plug the communication cable into the connector at the bottom back of the printer.
- 3 Secure the connector by tightening the screws.
- 4 Connect the cable to the host computer.
- 5 Turn host computer on.
- 6 After you have connected the printer, you must go into the printer configuration menu, “Communication Interface” submenu and set the interface type to parallel. (See page 32 to enter configuration menu.)

Power supply cable*Note: To avoid damage to the printer, connect the power supply cable last.*

Communication connector panel (RS-232C/USB shown)

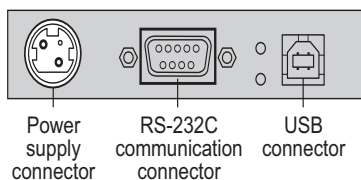

WARNING! Using this device without a grounded outlet is a safety hazard and voids the printer Warranty, Safety, FCC and CE Mark designation.

- 1 Plug the power cord into the power supply.
- 2 Route the cash drawer and power supply cables through the strain relief as shown in the next page, “Cable routing”.
- 3 Plug the power cord into the power supply, then plug the power supply into an outlet. The green LED on the top cover will light up.

Cable routing

To prevent the printer from becoming unplugged accidentally, make sure the cables are routed as shown in the illustration below.

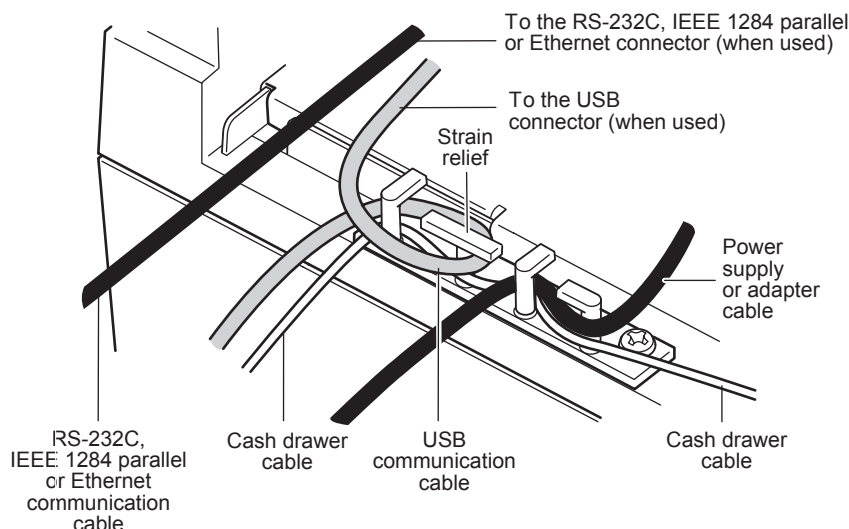

Test the printer

The test prints a list of various printer settings (Diagnostic form) and partially cuts the paper if a knife is installed (see sample on next page). The test printout items may vary depending on the printer model. This printout may be useful to a service representative if there is a problem. If something appears to be wrong with the test printout (such as missing or faded text), see page 44 in the troubleshooting section in this document, or refer to the interactive Printer Troubleshooting Guide at www.cognitivetpg.com.

At the end of the test printout are instructions how to enter the configuration menu. The configuration menu allows you to change the current settings of the printer. (See page 32 for more information on changing the configurations.)

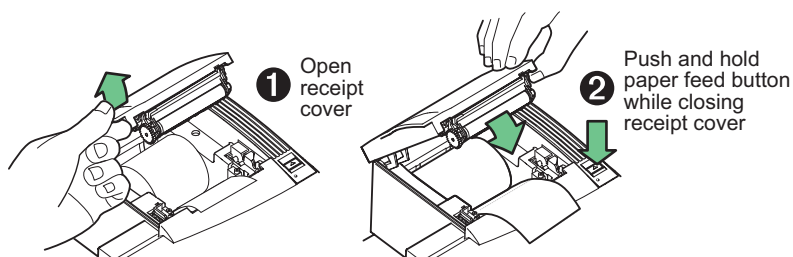

- 1 To run the test, either:
 - a Open (1) then while holding down the paper feed button, close the receipt cover (2).
 - OR
 - b Press the paper feed button and the reset button at the same time. The Diagnostic printout will print.
- 2 When the printer begins printing let go of the paper feed button. The diagnostic printout will print.
- 3 Review this printout for printer settings. If you wish to change any of these settings go to the configuration menu as instructed at the bottom of the printout.

Caution: Be extremely careful changing any of the printer settings to avoid inadvertently changing other settings that might affect the performance of the printer.

- 4 Make selections as instructed on the printout. (See page 32 for more information.)

Paper type can be changed in the configuration menu. Paper types and grades available:

- Type 0 - Monochrome grades
- Type 4 - Two-color grades
- Type 5 - Two-color grades

See page 48 and Programming guide for more information.

When the printer is configured for USB, this location will show either: "USB Driver Type: Printer Class" or "USB Driver Type: Comm Class."

*** A760 - Diagnostics Form ***

Model number : A760-1215
 Serial number : 000000000

Boot Firmware
 Revision : V3.02
 CRC : 9288
 P/N : 189-7600281A

Flash Firmware
 Revision : V3.01
 CRC : 3846
 P/N : 189-7600279A

H/W parameters
 Flash Memory Size : 2 Mbytes
 Flash Logos/Fonts : 960 kbytes
 Flash User Storage : 64 kbytes
 Flash Journal Size : 64 kbytes
 SRAM Size : 512 kbytes
 Head setting : D
 Motor ID : 0
 Paper Type Setting : Type 0, Monochrome
 Color Density Adj : n/a
 Print Density, Mono : 100%
 Max Speed : 180 mm/sec
 Max Power : 55 W
 Knife : Enabled
 Paper Low Sensor : Enabled
 Paper Low Extension : Disabled
 MICR : Enabled
 MICR Dual Pass : Disabled
 MICR DC offset : 7F
 MICR Discriminate : Auto
 Check Flip : Disabled
 Slip Alignment : 13h/19d

Comm. Interface
 RX Buffer Size : 4096
 Interface Type : RS232/USB

Parameters
 Baud Rate : 115200
 Data Bits : 8
 Stop Bit : 1
 Parity : NONE
 Flow Control : DTR/DSR
 Reception Errors : Ignore
 USB Driver Type : Printer Class
 USB Packet w/Error : Reject

To enter Printer Config Menu :
 1) Flip DIP switch #1 down
 2) Reset the printer, while holding the Paper Feed button down

*** A760 – Printer Config Menu ***

This config menu allows you to set general printer parameters

Sub-menus are entered and selections are made using the Paper Feed Button

- short click : Feed Button is quickly depressed then released
- long click : Feed button is held down for more than 1 second then released

CAUTION!!
 The settings are predetermined in factory and should generally not be changed. If you must change the settings do so carefully to avoid changing other functions.

***** MAIN MENU *****

Select a sub-menu :

- EXIT -> 1 click
- Print Current Configuration -> 2 clicks
- Set Communication Interface -> 3 clicks
- Set Diagnostics Modes -> 4 clicks
- Set Emulation/Software Options -> 5 clicks
- Set Hardware Options -> 6 clicks
- Set Paper Type -> 7 clicks

Enter code, then hold Button DOWN at least 1 second to validate

Important: Ensure that the configuration settings match your host computer; if not, enter the configuration menu to make changes.

Current printer tallies are printed after the diagnostic information and will vary per printer use.

Sample diagnostic menu and print test for serial connection(show approximately 60% of size). Ethernet diagnostic printout not shown. Ethernet parameters can not be changed in the configuration menu.

Chapter 4: Using the Printer

Printing on forms or checks

There are several types of transactions that may require the insertion of a form or check into the printer:

- Credit card transaction (requiring a merchant verification or authorization slip)
- Multiple-part forms such as credit transactions or merchandise returns
- Electronic funds transfers
- Electronic check

- Check printing (printing the date, payee, and amount on the check face)
- Check endorsement

Although the illustration below shows a check being inserted into the printer, these instructions apply to any type of form. The A760 can print on forms up to five parts thick.

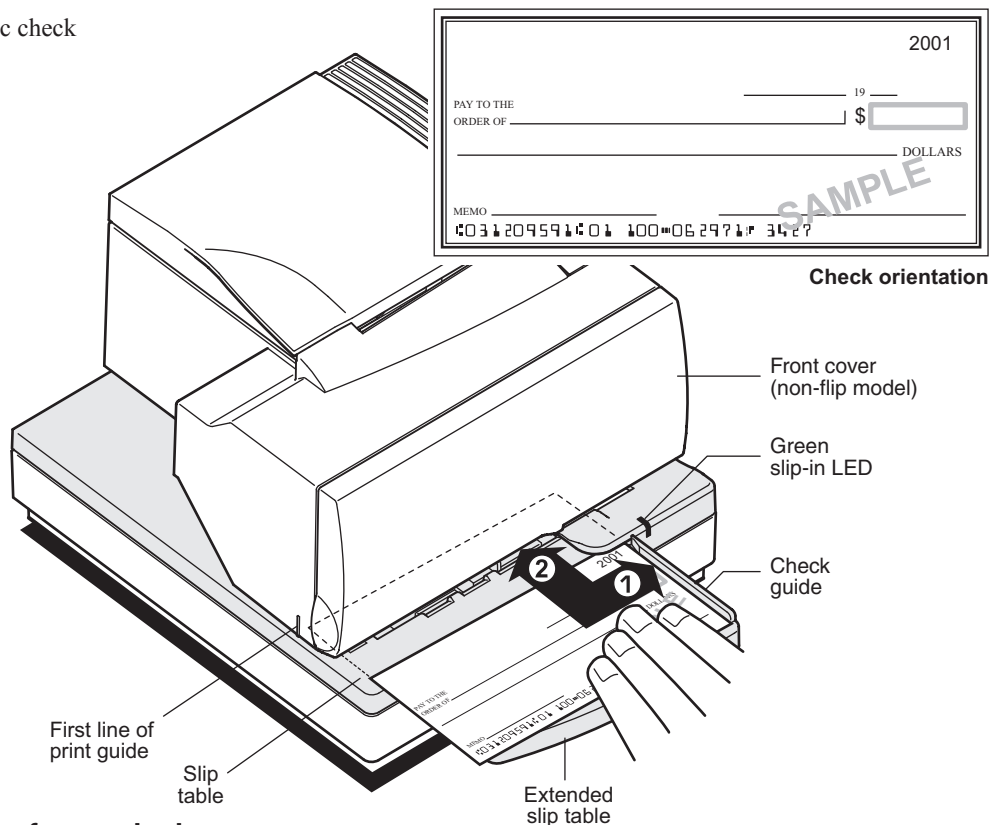

To print on a form or check:

- 1 Insert the form or check (check shown in the illustration) from the front and place it on the slip table with the print side up. If the form is extra long, you may need to insert it from the side. A slight resistance may be felt when the form comes in contact with the form stop.
- 2 Slide the form or check to the right until it aligns against the check guide.
- 3 Slide a short form or check toward the back of the printer until it contacts the form stop (it will not be able to go any further).

For a long form, position it appropriately using the first line of print guide on the left side of the printer.

The green slip-in LED on the slip table turns on when the form or check is properly inserted (the form has to cover two sensors on the slip table).

- 4 Follow the instructions from the host computer. The printer begins printing.
- 5 Remove the form or check after it has been fed back out.
- 6 Follow the instructions from the host computer to finish the transaction.

Verifying and validating checks

If the printer has the optional MICR check reader, checks are verified and then validated.

Note: To ensure that checks are properly verified and validated, they must be free of folds and wrinkles and inserted correctly into the MICR printer. Smooth a wrinkled or folded check for best performance.

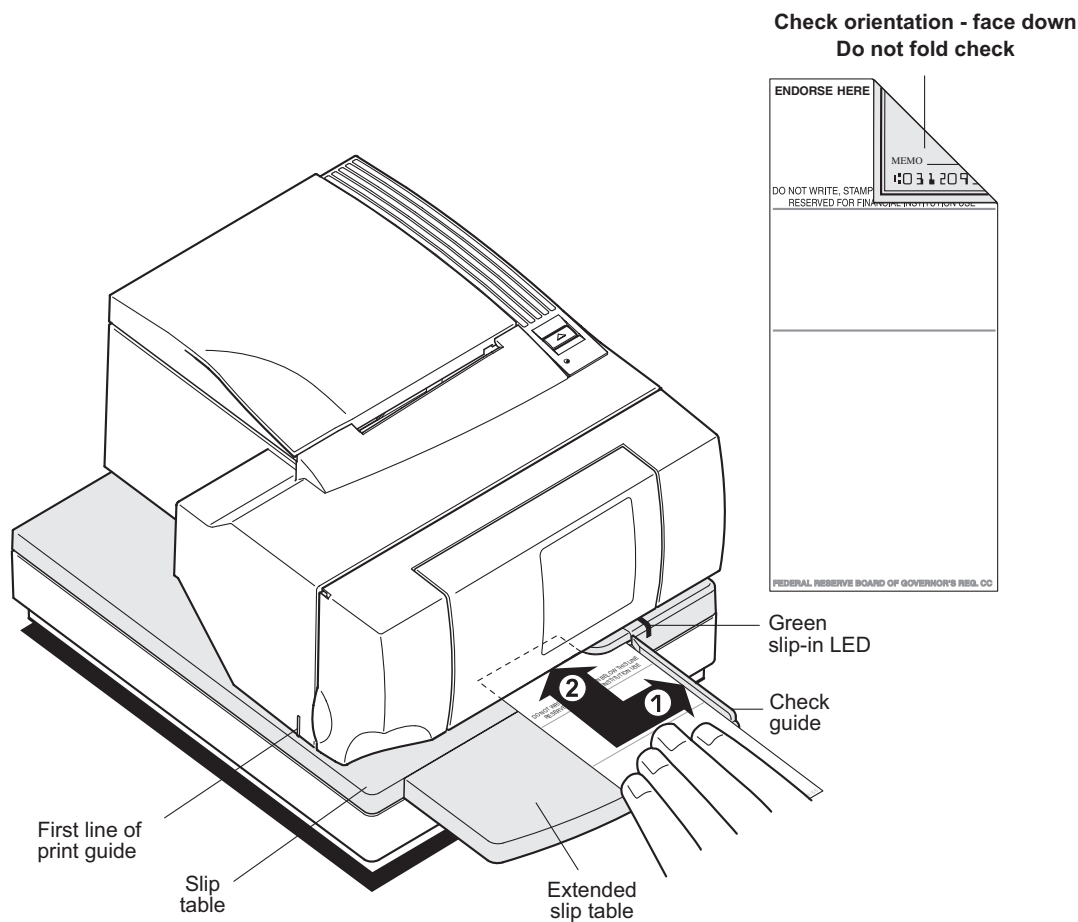

To verify and validate a check:

- 1 Place the check face down on the slip table, with the bottom edge of the check to the right. Move the check to the right until it aligns against the check guide.
- 2 Slide the check straight forward into the printer until it stops. The green slip-in LED on the front of the printer comes on.

Note: Hold the check to the right, against the check guide and release it as soon as the printer begins to run.

- 3 Follow the instructions on the host computer to complete the MICR process:

When instructed by the host, the check is fed into the printer, read and backed out to a position ready for endorsement, if desired.

Note: If the terminal indicates an incorrect read of the MICR:

- Remove the check.
 - Reinsert the check, ensuring instructions 1 through 3 are followed.
- 4 Only remove the check when it is fully released by the printer.
 - 5 Continue to follow the instructions from the host computer to finish the transaction.

Printer configurations

Printers are shipped with all the functions and parameters pre-set at the factory. Settings for various printer parameters can be changed. This menu is printed on the receipt and scrolls through instructions for selecting and changing user changeable functions or parameters.

Note: When changing the paper type, you will need to either send the “Set paper type” (ID 81 m n) command or use the “Set Paper Types” selection from the configuration menu. [See paper types available on page 48.](#)

Caution: Be extremely careful changing any of the printer settings to avoid inadvertently changing other settings that might affect the performance of the printer.

The following functions and parameters can be changed in the scrolling configuration menu (*except as noted):

- Communication Interface
 - RS-232C serial interface (9-pin)
 - RS-232C serial interface (25-pin)
 - Universal serial bus (USB)
 - Powered USB
 - IEEE 1284 parallel
 - Ethernet (*cannot be set -see next page)
- RS-232C serial interface settings
 - Baud rate
 - Data bits (*can not be changed)
 - Stop bits (*can not be changed)
 - Parity (*can not be changed)
 - Hardware (DTR/DSR) or software (XON/XOFF) flow control
 - Data reception errors
 - Alternate DTR/DSR
- Diagnostic Modes
 - Normal
 - Datascope
 - Receipt test
 - Slip test
 - MICR test
- Printer Emulations
 - A760 native mode
 - A756 emulation
 - A758 emulation
- Printer settings and functions
 - Emulation/software option sub-menu
 - Printer ID mode
 - Default lines per inch
 - Carriage return usage
 - Default font
 - Font size
 - Slip position (MICR printers)
 - Slip eject at receipt select
 - Hardware options sub-menu
 - Printhead setting
 - Paper type name
 - Color density
 - Print density (mono)
 - Power supply wattage (max power)
 - Alternate reset feature
 - Knife option
 - Paper low sensor
 - MICR option
 - MICR dual pass option

For more information about See this section

Using the configuration menu to configure the printer	“Configuring the printer” on page 32.
---	---

Ethernet option

Ethernet settings can not be changed in the configuration menu. If printer is currently configured for Ethernet use, refer to the Diagnostic Form printout for current settings.

To change the current Ethernet settings or to set printer for Ethernet, see “Ethernet terminology and setup”, in the [Programming supplement](#).

*** A760 – Diagnostics Form ***	
Model number	: A760-1125
Serial number	: A012451679
Boot Firmware	
Revision	: V1.03
CRC	: FFDE
P/N	: 189-7600118A
Flash Firmware	
Revision	: V1.05
CRC	: 7196
P/N	: 189-7600117A
H/W parameters	
Flash Memory Size	: 1 Mbytes
Flash Logos/Fonts	: 320 kbytes
Flash User Storage	: 0 kbytes
SRAM Size	: 256 kbytes
Head setting	: D
Paper Type Name	: Type 1, Version 0
Color Density Adj	: 100%
Max Speed	: 100 mm/sec
Max Power	: 55 W
Alternate Reset	: Disabled
Knife	: Enabled
Paper Low Sensor	: Disabled
MICR	: Enabled
MICR Dual Pass	: Disabled
MICR DC Offset	: 80
Check Flip	: Enabled
Comm. Interface	
RX Buffer Size	: 4096
Interface type	: 10BaseT
Parameters	
MAC Address	: 00:E0:70:00:50:2B
IP Address	: 10.1.2.10
Net Mask	: 0.0.0.0
Gateway	: 0.0.0.0
LP Daemon	: Disabled
Telnet	: Enabled
Raw TCPIP Port	: 9001
DHCP	: Enabled
Inactivity Timeout	: Enabled
Keep Alive Pings	: Disabled
On Error & Full	: Reject Data
Resident Code Pages	: 437, 850, 852, 857, 858 860, 863, 865, 866 1252, 862, 737, 874
Logo(s) Defined	: YES
User Char(s) defined	: NO
Special Unused	: NO
To enter Printer Config Menu :	
1) Flip DIP switch #1 down	
2) Reset the printer, while holding the Paper Feed button down	

Ethernet Sample diagnostic printout

Highlighted area shows Ethernet settings. These settings can not be changed through the configuration menu and must be set by sending commands from the host. See Ethernet terminology and setup, in the Programming supplement.

Configuring the printer

The configuration menu allows you to select functions or change various settings for the printer. Instructions printed on the receipt, guide you through the processes.

Note: When changing the paper type, you will need to either send the “Set paper type” (1D 81 m n) command or use the “Set Paper Type” selection from the configuration menu. See paper types available on page 48.

Caution: Be extremely careful changing any of the printer settings to avoid inadvertently changing other settings that might affect the performance of the printer.

- 1 Open the receipt cover and check if there is paper in the printer. If not, follow the instructions on page 18 for loading paper.
- 2 Turn the printer so the back is facing you.

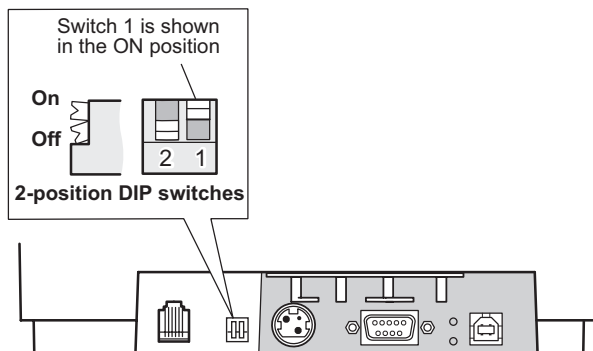

Back of printer

- 3 Set DIP switch 1 to the On position (up).
- 4 Open the front cover of the printer and press the reset button while holding the paper feed button.

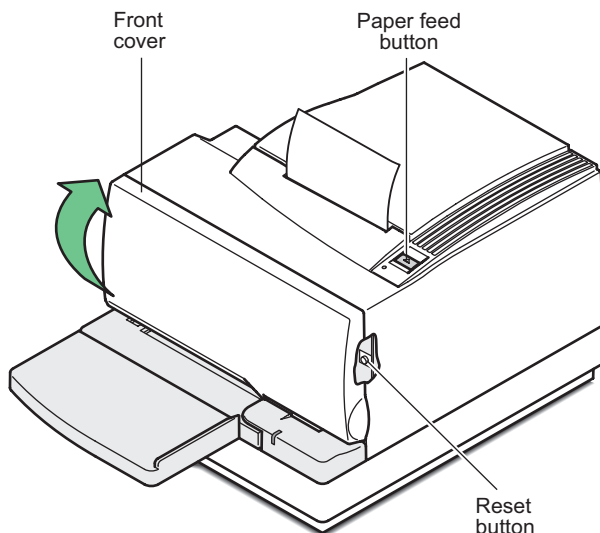

- The printer beeps, prints the diagnostic form and the configuration main menu.
- The printer pauses and waits for a main menu selection to be made (see sample printout below.)

*** A760 – Printer Config Menu ***

This config menu allows you to set general printer parameters

Sub-menus are entered and selections are made using the Paper Feed Button

- short click : Feed Button is quickly depressed then released
- long click : Feed Button is held down more than 1 second then released

CAUTION !!

The settings are predetermined in factory and should generally not be changed. If you must change the settings do so carefully to avoid changing other functions.

***** MAIN MENU *****

Select a sub-menu :

- EXIT -> 1 click
- Print Current Configuration -> 2 clicks
- Set Communication Interface -> 3 clicks
- Set Diagnostics Modes -> 4 clicks
- Set Emulation/Software Options -> 5 clicks
- Set Hardware Options -> 6 clicks
- Set Paper Type -> 7 clicks

Enter code, than hold Button DOWN at least 1 second to validate

- 5 Follow the printed instructions on the scrolling menu by pressing the paper feed button as indicated below to make selections.
 - Indicate **Yes** with a long click. (Press and hold paper feed button for more than one second.)
 - Indicate **No** with a short click. (Press paper feed button quickly.)
- 6 Continue through your menu selections until you are asked, “Save New Parameters?” Select “Yes” or “No”.
 - a If you wish to save, select “Yes”, then return DIP switch 1 to the Off position (down).
 - b Press the reset button. The printer resets with the new selections. You can verify the setting by pressing the paper feed button to print out a diagnostics form or by holding the paper feed button and opening and closing the receipt cover.
- 7 If you would like to continue configuring the printer, select “No”. The printer returns to the configuration menu where you can set parameters again.

Communication interface

To change the communication interface settings (except Ethernet), enter the configuration menu, select “Set Communication Interface” from the main menu and answer “Yes” to “SET INTERFACE TYPE?” printed on the receipt.

Caution: *Be extremely careful changing any of the printer settings to avoid inadvertently changing other settings that might affect the performance of the printer.*

Press the paper feed button as instructed to select the communication interface you want.

- Communication interface
 - RS-232C interface
 - USB
 - IEEE 1284 parallel (see below)
 - Ethernet (see “Ethernet settings” below.)

RS-232C serial interface settings

To change the RS-232C serial interface settings, enter the configuration menu, select “Set Communication Interface” from the main menu and answer “No” to “SET INTERFACE TYPE?” printed on the receipt. This will take you to the instructions for selecting the RS-232C settings.

Caution: *Be extremely careful changing any of the printer settings to avoid inadvertently changing other settings that might affect the performance of the printer.*

Press the paper feed button as instructed on the configuration menu to select the RS-232C settings you want to change:

- Baud rate
 - 115200 baud
 - 57600 baud
 - 38400 baud
 - 19200 baud
 - 9600 baud
 - 4800 baud
 - 2400 baud
 - 1200 baud
- Number of data bits can not be changed (not shown on printout)
- Stop bits can not be changed (not shown on printout)
- Parity can not be changed (not shown on printout)

- Hardware flow control
 - Software (XON/XOFF)
 - Hardware (DTR/DSR)
- Data reception errors
 - Ignore errors
 - Print “?”
- Alternate DTR/DSR
 - Enabled
 - Disabled

Note: *Press the paper feed button for at least one second to validate the selection.*

For more information about See this section

Setting the RS-232C Serial interface settings

[“Configuring the printer” page 32.](#)

Parallel communication

For the printer to operate in parallel, you must go into the configuration menu, “Communication Interface” submenu and set interface type to parallel.

Ethernet settings

For the printer to operate with Ethernet, a series of commands must be set within the printer. These commands can only be set through the host computer and are not configurable through the printer configuration menu.

See [A760 User programming supplement](#), “Ethernet terminology and setup.”

Diagnostic modes

To change the diagnostic modes enter the configuration menu, select “Set Diagnostic Modes” from the main menu and select one of the following modes:

- **Normal:** normal operating mode of the printer.
- **Datascopes:** the receipt printer prints incoming commands and data in hexadecimal format to help troubleshoot communication problems.
- **Receipt test:** the receipt printer prints two code pages to verify proper printing of the receipt.
- **Slip test:** the slip printer prints two code pages to verify the slip printer is operating properly.
- **MICR test mode:** the receipt printer prints all characters recognized by the MICR (check reader) to verify proper reading of an inserted check.

Caution: Be extremely careful changing any of the printer settings to avoid inadvertently changing other settings that might affect the performance of the printer.

See “Configuring the printer,” page 32 for instructions on how to enter the configuration menu.

Enable or disable data scope mode

The data scope mode test prints a hexadecimal dump of all data sent to the printer: “1” prints as hexadecimal 31, “A” as hexadecimal 41 and so on. This helps troubleshoot communication problems and runs during a normal application (after being enabled through printer configuration).

Note: Data scope mode is usually considered a level 1 diagnostic test.

Data scope mode is enabled and disabled by selecting the “Diagnostic Modes” sub-menu of the configuration menu.

Press the paper feed button as instructed on the “Diagnostic Modes Menu” to enable or disable the data scope mode test.

- Off, normal mode (Data scope mode disabled)
- Data scope mode (enabled)

Note: Press the paper feed button for at least one second to validate the selection.

To run the data scope mode:

- 1 After you have enabled the data scope mode, exit the configuration menu.
- 2 Run a transaction from the host computer.
All commands and data sent from the host computer will be printed as hexadecimal characters as shown in the illustration.

To exit the data scope mode:

- 1 Enter the configuration menu again.
See “Configuring the printer,” page 32.

```

10                                     :
1B 76                                 : v
1C 12 20 20 20 20 20 20 20 20 20 :
20 20 2A 20 20 43 4F 4E 54 49 4E 55 : * CONTINU
4F 55 53 20 52 4F 4C 4C 20 20 2A 20 : OUS ROLL *
20 20 17 1C 20 20 20 20 20 20 20 :
20 20 20 20 20 20 20 20 20 20 20 :
20 20 20 20 20 20 51 75 61 6E 74 69 :      Quanti
74 79 20 20 34 35 20 20 20 20 20 20 : ty 45
20 20 20 20 20 20 20 20 20 24 31 36 :      $16
2E 36 35 17 1C 20 20 20 20 20 20 : .65

```

- 2 Disable the data scope mode.

- 3 Exit the configuration menu.

The printer is on-line and can communicate normally with the host computer.

For more information about See this section

Enabling the data scope mode “Configuring the printer”, page 32

Enable or disable receipt test mode

The receipt test mode verifies proper receipt printing. Receipt test is enabled and disabled by selecting the “Diagnostic Modes” sub-menu of the configuration menu. See “Configuring the printer”, page 32 for instructions on how to enter the configuration menu.

To run the Receipt test mode:

- 1 Enable the receipt test mode in the configuration menu.
- 2 Exit the configuration menu.
- 3 Push the paper feed button. The receipt station prints two code pages and cuts the receipt.
- 4 To repeat this test, push the paper feed button again.

To exit the receipt test mode:

- 1 Enter the configuration menu again. (See “Configuring the printer”, page 32.)
 - 2 Disable the receipt test mode.
 - 3 Exit the configuration menu.
- The printer is on-line and can again communicate normally with the host computer.

Enable or disable slip test mode

The slip test mode verifies proper printing on a slip. Slip test is enabled or disabled by selecting the “Diagnostic Modes” sub-menu of the configuration menu. See “Configuring the printer”, page 32 for instructions on how to enter the configuration menu.

To run the slip test mode:

- 1 Enable the slip test mode in the configuration menu.
- 2 Exit the configuration menu.
- 3 Insert a slip into the slip station.
- 4 Push the paper feed button. Two code pages will be printed.
- 5 To repeat this test, preform steps 3 and 4 again.

To exit the slip test mode:

- 1 Enter the configuration menu again. (See “Configuring the printer”, page 32.)
 - 2 Disable the slip test mode.
 - 3 Exit the configuration menu.
- The printer is on-line and can again communicate normally with the host computer.

Enable or disable MICR test mode

MICR test mode tests the MICR operation. In this mode the MICR reads the characters on a check, but instead of transmitting the values to the software it prints them out.

MICR test is enabled or disabled by selecting the “Diagnostic Modes” sub-menu of the configuration menu. See “Configuring the printer”, page 32 for instructions on how to enter the configuration menu.

To run the MICR test mode:

- 1 Enable the MICR test mode through the [configuration menu](#), [see page 32](#). Then exit the configuration menu.
- 2 Insert a check into the slip station. (See “[Verifying and validating checks](#),” [page 28](#).)
- 3 Once a check is detected by the printer, the platen closes and the characters are read by the MICR check reader. The decoded data is printed as characters on receipt paper. The platen is then opened, and the test is re-started.
- 4 The printed characters should match the characters on the check. If the MICR check reader misreads a character, a question mark “?” is printed. If no characters can be read, “NO MICR CHARACTERS” is printed.

```
MICR Data :
)123456789)12345677(      010925
```

To exit the MICR test mode:

- 1 Enter the configuration menu again.
 - 2 Disable the MICR test mode.
 - 3 Exit the configuration menu.
- The printer returns to normal mode and can again communicate with the host computer.

Setting the printer emulations

Printer emulations determine what commands are available to the printer. To change the printer emulations settings, select the “Emulations/Software Options” sub-menu of the main menu and answer “Yes” to “Set the Printer Emulations?” printed on the receipt. This will take you to the instructions for setting the printer emulation.

Caution: *Be extremely careful changing any of the printer settings to avoid inadvertently changing other settings that might affect the performance of the printer.*

Press the paper feed button as instructed to select the printer emulation you want.

- A760 native mode
- A758 emulation
- A756 emulation

Note: *The A756 and A758 emulations do not recognize the ColorPOS[®] commands.*

Note: *Press the paper feed button for at least one second to validate the selection.*

For more information about	See this section
Setting the printer emulation and print setup	“Configuring the printer”, page 32 and “Emulation modes”, in the A760 Programming supplement.

Printer settings and functions

To change the printer settings and functions, enter the configuration menu, select the sub-menu from the main menu and answer the questions printed on the receipt until you come to the instructions for selecting the printer settings.

Caution: *Be extremely careful changing any of the printer settings to avoid inadvertently changing other settings that might affect the performance of the printer.*

Note: *If it becomes necessary to clear lasting printer tallies, please contact an CognitiveTPG representative for instructions.*

Press the paper feed button as instructed to select the printer settings you want.

Select the emulation/software options sub-menu to set:

- | | |
|---|--|
| <ul style="list-style-type: none"> • Printer ID mode
This function is used to determine what printer ID value is returned in response to a Transmit printer ID command (1D 49 n) when the printer is in A756 emulation mode. The printer can be configured to send back the ID of the A760, A758 or A756. • Default lines per inch
This function allows you to set the default for lines per inch to either: <ul style="list-style-type: none"> 8.13 lines per inch 7.52 lines per inch 6.77 lines per inch 6.00 lines per inch • Carriage return usage
This function allows the printer to ignore or use the <i>carriage return</i> (hexadecimal 0D) command depending on the application. Some applications expect the command to be ignored while others use the command as a print command. | <ul style="list-style-type: none"> • Default font
Sets the default font for monochrome, two-color, and Application Compatible Escape Commands emulations. • Font size
Allows user to set font size for the emulation being used. • Slip position (MICR printers)
This function is used by manufacturing to align the carriage. • Slip eject at receipt select
When enabled the printer ejects the slip when receipt is selected. |
|---|--|

Select the hardware options sub-menu to set:

- Printhead setting

This setting is the printhead energy rating and must match the rating marked on the the front right of the thermal mechanism in the printer. Whenever a new thermal mechanism is installed, this setting must match the indicated energy rating on the mechanism. (See *A760 Service Guide* for replacing the thremal mechanism.)

- Paper type name

Sets the printer to optimum performance for paper being used. This can also be done through the command 1D 81 *m n*. See *Programming Supplement* for command usage or [page 32](#) to enter the configuration menu.

Available paper types may vary.

Currently these are 3 types:

0 – monochrome

4 – two-color

5 – two-color

(See [page 48](#) for available paper manufacturers.)

- Color density

Adjusts printhead energy level to darken color printing or adjust to paper variations. When the printer prints high-density color print lines (text or graphics), it automatically slows down. Factory setting is 100%.

WARNING: Choose an energy level no higher than necessary to achieve a dark printout. Failure to observe this rule may result in a printer service call or voiding the printer warranty. Running at a higher energy level will reduce the printhead life. Consult your CognitiveTPG technical support if you have any questions.

- Print density (monochrome papers only)

Adjusts printhead energy level to darken printout or adjust for paper variations. When the printer prints high-density color print lines (text or graphics), it automatically slows down. Factory setting is 100%.

WARNING: Choose a print density setting no higher than necessary to achieve acceptable print density. Failure to observe this rule may result in a printer service call and may void the printer warranty. Running at a higher energy level will reduce the printhead life. Consult your CognitiveTPG technical support specialist if you have questions.

- Power supply wattage (Max power)

You can choose between a 55-watt or 75-watt power supply. This matches the wattage of the printer to the power supply.

55-watt power supply (standard)

75-watt power supply (Enables printer to optimize speed at higher dot coverage.)

- Alternate reset feature

This feature allows you to reset the A760 by opening and closing the front cover instead of using the dip switch or reset button.

- Knife option

This should only be changed if the option is added or removed.

- Paper low sensor

Senses when the paper roll is getting low on paper. See [Troubleshooting section “Receipt paper is low” page 42](#).

- MICR option

Allows the user to enable or disable the MICR option to read checks. This setting should only be changed if the option is added or removed.

- MICR dual pass option

This feature when enabled allows the printer to attempt a second reading of the check MICR number, if the first attempt was unsuccessful.

For more information about **See this section**

Setting the printer functions and settings

[“Configuring the printer” \(See page 32.\)](#)

Preventing overheating of the printhead

There are restrictions on the duty cycle because of the heat generated by the thermal printhead when printing solid blocks (regardless of the length of the block in relation to the print line). The restrictions are ambient temperature, the percentage of time (measured against one minute) of continuous solid printing, and the amount of coverage.

Keep in mind that the ambient temperature may be affected by factors such as direct exposure to sun or close proximity to heating elements.

Caution: *When the duty cycle exceeds the limits shown in the table, the receipt printhead will heat up and shut down. This may damage the printhead.*

To avoid this problem, do one or a combination of the following:

- 1 Reduce the amount of coverage.
- 2 Reduce the time of continuous solid printing.
- 3 Reduce the ambient temperature.

Allowable duty cycle (measured over one minute of continuous printing)

Amount of solid coverage	Ambient temperature		
	25°C	35° C	50° C
20%	100%	50%	20%
40%	50%	25%	10%
100%	20%	10%	4%

Duty cycle

Percentage of time that the specified "Amount of solid coverage" can be printed during a one minute period of time.

Example: at 20% solid coverage, 35° C temperature, a 50% duty cycle is to be used, resulting in 30 seconds of printing and 30 seconds without printing.

For reference:

- A typical receipt with text (contains some blank spaces) is approximately 12% dot coverage.
- A full line of text characters (every cell on the line has a character in it) is approximately 25% dot coverage.
- Graphics are approximately 40% dot coverage.
- Barcodes are approximately 50% dot coverage.
- A solid black line is 100% dot coverage.

Troubleshooting the printer

The A760 ColorPOS® printer is a simple, generally trouble-free printer, however unexpected conditions may arise. For example, the power supply may be disconnected or the thermal printhead may overheat.

The on-line, paper status, error LED on the operator panel may signal that something is wrong. The light on the front right side of the printer is used only to indicate when a form is inserted properly. It does not indicate an error.

For some unexpected conditions, the printer communicates the information to the host computer and relies on the application to indicate what the condition is.

The information on the following pages describes some conditions that you may encounter: conditions that you can easily fix, and others that you will need to contact a service representative for. For additional technical support, you can use the [interactive Printer Troubleshooting Guide](http://www.cognitivetpg.com) at our website, www.cognitivetpg.com.

You may be able to correct many of the conditions without calling for service. However, if a condition persists, contact a service representative. See “[Contacting a service representative](#)” at the end of this chapter.

If an unexpected condition has occurred, take the following general steps:

- 1 Cycle the power of the printer and note its behavior.
- 2 Check the on-line, paper status, error LED and compare its behavior to the following table.

Status	LED behavior
Power off	Off
Firmware download	Fast blink
Level 0 diagnostics (entered at power on or in reset)	Fast blink
Paper low Temperature error Voltage error	Slow blink
Cover open (receipt or slip) Paper out Carriage jam Slip jam Knife jam	Fast blink
All other states	On

- 3 Test the receipt printer or slip printer by printing a sample test print as described elsewhere in this document.
- 4 Determine if the condition is with the thermal receipt printer or the impact slip printer and refer to the tables on the following pages.

Printer beeps

Condition	Possible causes	What to do
Printer beeps in a single, double, or triple pattern at first power on, the on-line, paper status, error LED blinks in the same pattern, and the printer won't power up.	The printer has a problem with its electronics.	Contact a service representative.
Printer beeps during normal operation.	The printer may be programmed to beep during normal operation by the software application used on the host computer.	Consult your application software manual.

Printer will not print

Condition	Possible causes	What to do
The on-line, paper status, error LED is blinking and the printer won't print.	The receipt paper may be out, the cover open, the knife jammed, the supply voltage out of range, or the printhead temperature out of range.	Check that the receipt paper is properly loaded and covers are closed. See the table at the beginning of this section. For problems not user correctable, contact a service representative.
Printer doesn't have power (LED not on)	Power supply may be defective.	If the power supply is plugged in, but does not come on, you will need to order a new power supply. See "Power supply and power cords" page 49.
Printer has power but doesn't print.	Cables may not be connected properly. by plugging it into an outlet. DIP switches not set correctly. All other causes.	Check all cable connections. Check that the host computer and power supply are both on (the power supply is turned on). See "Connect the cables" page 21. Check the switch setting. DIP switch one should be off (down) for normal operation. Contact a service representative.

On-line, paper status, error LED flashes

Condition	Possible causes	What to do
On-line, paper status, error LED is blinking.	Receipt paper is out. Change the paper now. Do not run a transaction without paper. Data may be lost.	Receipt paper is out. Change the paper immediately. See "Load and change the receipt paper" page 18.
	Receipt or front cover is open.	Close the cover. The printer will not operate with any of the covers open.
	The knife is jammed.	Open the receipt cover and check the knife. Clear any jammed paper you can see. Tear off any excess paper against the tear-off blade.
	The slip is jammed.	Open the front cover and clear paper from path.
	The carriage is jammed.	Open front cover and clear paper from path.
	Receipt paper is low.	There are about 4.5 meters, \pm 3 meters, (15 feet, \pm 10 feet) of paper left. Change the paper soon to avoid running out of paper part way through a transaction. See "Load and change the receipt paper" page 18.
	AC supply voltage is out of range.	If paper is not low and no conditions indicate that the thermal printhead is too hot, the power supply voltage is out of range. Contact a service representative.
	Thermal printhead temperature is out of range.	The printhead may overheat when printing in a room where the temperature is above the recommended operating temperature or when printing high density graphics continuously, regardless of the room temperature. In either case, the printer will shut off. If the temperature of the printhead is too hot, adjust the room temperature or move the printer to a cooler location. If the printhead is overheating because of printing high density graphics continuously, reduce the demand on the printer.

Slip-in LED does not light (rectangular green LED on slip table)

Condition	Possible causes	What to do
LED does not light	No check or form inserted into printer.	
	Check or form incorrectly inserted.	Ensure the check or form is aligned against the check guide. See "Printing on forms or checks" page 27.

Poor forms print quality

Condition	Possible causes	What to do
Printer starts to print, but stops while the form is being printed.	Communication error or software error.	Check the interface cable. Check that the software is working properly.
Forms print is light or spotty.	Form not inserted incorrectly.	See "Printing on forms or checks" page 27.
	Impact printhead is dirty or defective.	Contact a service representative.
	Improper internal cable connections.	Contact a service representative.
	Ribbon cassette is defective	See "Installing or replacing the ribbon cassette" page 19.
Ribbon cassette is worn.	Replace the ribbon cassette.	See "Installing or replacing the ribbon cassette" page 19.
Light print, smudging, or slip skews.	Platen gap needs adjustment.	Contact a service representative.

Poor receipt print quality

Condition	Possible causes	What to do
Colored stripe on receipt.	Paper is low.	Change the paper.
Receipt does not come out all the way.	Paper is jammed.	Open the receipt cover, inspect the knife, and clear any jammed paper.
Printer starts to print, but stops while the receipt is being printed.	Paper is jammed.	Open the receipt cover, inspect the knife, and clear any jammed paper.
Print is light or spotty.	Paper roll loaded incorrectly.	Check that the paper is loaded properly.
	Thermal printhead is dirty.	Use recommended thermal receipt paper. Clean the thermal printhead with an alcohol pen prior to going back to an approved paper. Do not spray the thermal printhead with household cleaner as this may damage it and the electronics. The thermal printhead does not normally require cleaning if the recommended paper grades are used. If non-recommended paper has been used for an extended period of time, cleaning the printhead with an alcohol pen will not be of much benefit.
	Improper internal cable connections.	Contact a service representative.
	Printhead is defective.	Contact a service representative.

continued...

Poor receipt print quality

Condition	Possible causes	What to do
Color print is light.	Variations in paper.	Increase energy level of printhead in "Color Density Adj" of the printer configuration menu (see "Configuring the printer" page 32 and the Programming Supplement).
Inconsistent printing, no two-color print.	Paper type used and paper type setting do not match	Print diagnostic form and verify paper type setting to type 0, 1, 4, or 5 (see "Configuring the printer" page 32, paper type on page 48 , and the Programming Supplement).
Vertical column of print is missing, one side of receipt is missing, or top or bottom half of characters are missing.	Printhead is defective.	Contact a service representative.

Slip station and MICR problems

Condition	Possible causes	What to do
Slip table LED does not come on.	Form or check not inserted properly.	Line up the form or check against the check guide (wall) and slide it toward the back of the printer until it contacts the form stop and can't go any further. Extra long forms may need to be inserted from the side to disengage the Form Stop. See "Printing on forms or checks" page 27 or "Verifying and validating checks" page 28.
Forms or checks skew or catch in the slip station.	There is an obstruction or paper jam in the slip station.	Open the front cover and check for any paper jams or obvious obstruction in the slip station. Clear the obstruction or jammed paper.

continued...

Slip station and MICR problems

Condition	Possible causes	What to do
The optional MICR (Magnetic Ink Character Recognition) check reader does not read or misreads checks.	The check is inserted improperly.	Make sure the check is inserted properly with the MICR characters down. See “Verifying and validating checks” page 28.
	The check is fraudulent.	Make sure that the check is not fraudulent. On fraudulent checks, the characters the printer reads may be different from those that are visible on the check face.
	A nearby magnetic source is interfering with the check reader.	Devices, such as CRT monitors, security devices or large metal surfaces that are near the printer can affect the printer’s magnetic field, causing intermittent reading errors when the MICR check reader is in operation. Move the printer away from such items or areas.

Knife does not operate

Condition	Possible causes	What to do
Receipt is not cut.	Paper is jammed.	Open the receipt cover, inspect the knife, and clear any jammed paper.
	The printer has a knife but the firmware is not configured for a knife.	Enable the knife option by reconfiguring the printer. See “Configuring the printer” page 32.
	All other problems.	Contact a service representative.

Other conditions

The following problems all need to be corrected by a qualified service representative. See the next section, “Contacting a service representative.”

- MICR check reader not operating properly
- Forms not feeding into the slip/forms area properly
- Missing dots in slip or forms printing
- Printer will not cycle or stop when required
- Illegible characters
- Paper will not feed
- Knife will not cycle or cut
- Platen will not open or close
- Printer will not communicate with the host computer

Contacting a service representative

For serious problems, such as the printer not printing, not communicating with the host computer, or not turning on, contact CognitiveTPG technical support at (800) 732-8950, option 4, or by e-mail at tsupport@cognitivetpg.com.

Returning a printer

Follow these instructions if you need to return a printer for servicing.

- 1 If you are sending the printer to CognitiveTPG for repair, please [visit the Support section](#) of the CognitiveTPG website to [submit an on-line RMA request form](#). You may also contact us at (800) 732-8950, option 4 or direct at (607) 274-2490, option 4 to request an RMA number.

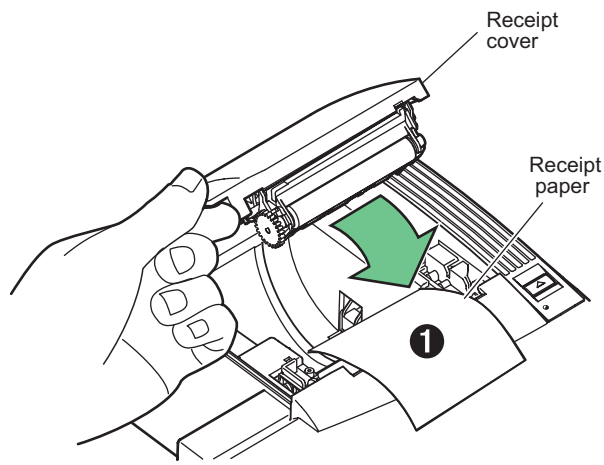

2. Pack the printer as follows:
 - a. Place receipt paper between the receipt cover and the printhead for protection (1).
 - b. Remove the ribbon cassette (2).
 - c. Place the two cardboard supports on the slip table, as shown on the left below (3).
 - d. Place the printer in the corrugated pack (4), place the packed printer in the box (not shown) and secure the box with packing tape.
3. An RMA # and return address will be provided when the RMA request is processed. Please be sure to write the RMA# on the outside of the box and return to the address provided.

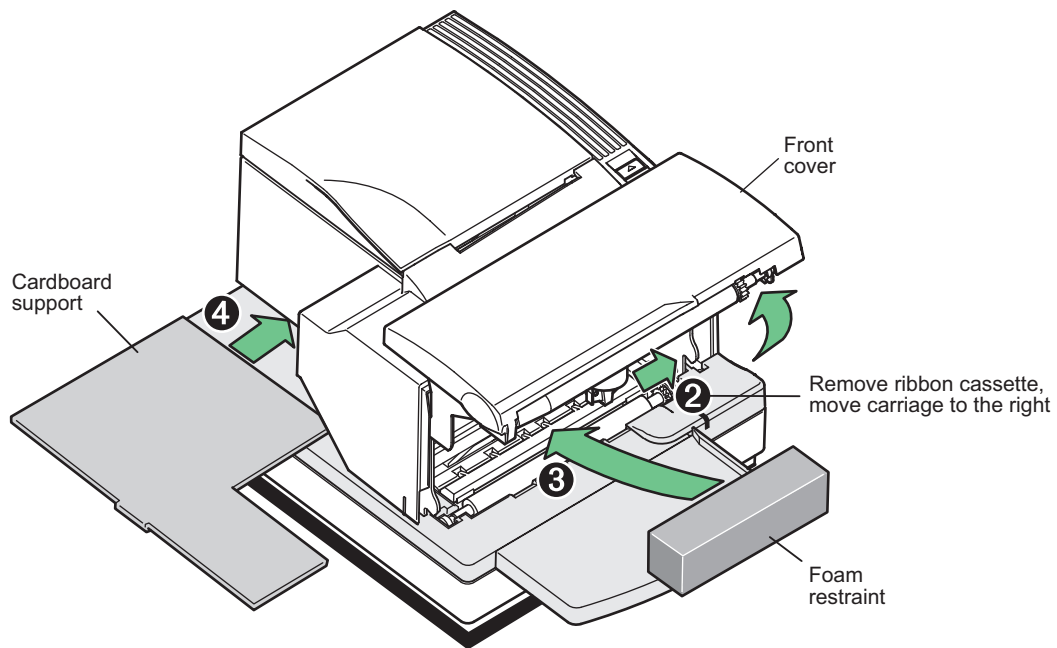

Chapter 5: Paper and supplies

Ordering from CognitiveTPG

Printer parts, accessories, and small quantities of paper can be ordered directly from CognitiveTPG. While the CognitiveTPG part numbers are listed here for your convenience, keep in mind that these numbers may change before this guide is outdated. Please visit www.cognitivetpg.com for the most current information. To place an order or get more non-technical information, call your CognitiveTPG representative or the sales line at (800) 732-8950.

CognitiveTPG is able to provide paper in small lots to facilitate product evaluation and testing. Contact your CognitiveTPG representative for more information on ordering.

Ordering thermal paper

Thermal paper specifications

The printer requires qualified thermal paper with the following dimensions:

Width	Diameter	Length
80 ± 0.2 mm (3.15 ± 0.02")	90 mm max. (3.54")	98 meters (322') 2.4 mil thick

The paper must not be attached at the core. Use paper with a colored stripe at the end to indicate that the paper is running low.

The above lengths are based on a core diameter of 22 ± 0.5 mm (0.87") outside, 11.5 ± 0.5 mm (0.45") inside.

Manufacturers

Contact the converter of your choice to order paper. CognitiveTPG recommends the following paper grades produced by their respective manufacturers. There are a number of paper converters qualified to provide this paper, provided the POS rolls are from these recommended grades. Please visit www.cognitivetpg.com for the most current information.

Note: When changing paper type, you will need to set the printer to that paper type by sending the "Set paper type" command (ID 81 m n) or by changing the paper type setting in the configuration menu. (See Programming Supplement or page 32 to enter the configuration menu.)

Caution: Use of other (non-CognitiveTPG tested/approved) papers may result in excessive print head contamination, light print, missing print, and/or void the printer warranty.

Monochrome (black ink) paper:

Qualified manufacturers	Phone/Fax	Paper grade
Appleton Papers, Inc. (USA) 825 E. Wisconsin Ave. Appleton, WI 54912 http://www.appletonideas.com	Voice: (800) 922-1729 Fax: (800) 922-1712	Alpha 400-2.3 (was T1030) Alpha 800-2.4 (was T1012A) POS-Plus 600-2.4 Alpha 900-3.4 (was Superior) All current Appleton papers are BPA-free
Jujo Thermal Ltd. P.O. Box 92 FI-27501 Kauttua, Finland http://www.jujothermal.com/	Voice: 358 (0) 10 303 200 Fax: 358 (0) 10 303 2419	AF50KS-E3 AP62KS-E3

Kanzaki Specialty Papers (USA) 20 Cummings St. Ware, MA 01082-2002 http://www.kanzakiusa.com/	Voice: (888) 526-9254 Fax: (413) 731-8864	P30023 (was P-300), P31023 (was P-310), P35024 (was P-350), P35032 (was P-354), P39023 (BPA free, was P-390), P30521 (BPA free) P30523 (BPA free), P31523 (BPA free), P35532 (BPA free)
--	--	--

Koehler UK Ltd. (Great Britain) 2 White Oak Square London Road Swanley, Kent BR8 7AG, U.K. http://www.koehlerpaper.com/en/	Voice: (44) 1322 661010 Fax: (44) 1322 614656	KT55-F20 (WN-T55)
---	--	-------------------

-or-

Koehler AG Hauptstr. 2-4 D-77704 Oberkirch, Germany	Voice: (49) 7802 81-0 Fax: (49) 7802 81-4330
--	---

Mitsubishi Int'l Corp. (USA) 655 Third Ave. New York, New York 10017 http://www.mitsubishicorp.com/us/en/	Voice: (212) 605-2000 Fax: (212) 605-2597	P-5035 T-8051 TP-8065 PP-5051
--	--	--

OJI Paper Company Ltd. Ginza 4-chome Tokyo 104, Japan http://www.ojipaper.co.jp/english/	Voice: (81)3-3563-1111 Fax: (81)3-3563-1135	KF-60 PD-170R PD-160R
---	--	-----------------------------

Thermal Solutions Intl, Inc. 6740 Broadview Ave, Suite D Jacksonville, FL 32254 http://thermalsolutionsinternational.com	Voice: (800) 479-6070 (904) 860-1966 Fax: (904) 646-4530	19018RDT Features: 30% post-consumer waste, recycled/BPA free
---	--	--

Two-color paper:

Qualified manufacturers	Phone/Fax	Paper grade
Mitsubishi Int'l Corp. (USA) 655 Third Ave. New York, New York 10017 http://www.mitsubishicorp.com/us/en/	Voice: (212) 605-2000 Fax: (212) 605-2597	PB-770 (Blue and Black)

Ordering paper from CognitiveTPG

CognitiveTPG can provide paper in small lots to facilitate product evaluation and testing.

To order monochrome paper rolls directly from CognitiveTPG, use the following part numbers:

Standard density	50 Rolls, 90 mm dia.	#A152-0034
Light density	50 Rolls, 90 mm dia.	#A152-0035

Ordering miscellaneous supplies

Cash drawers

Order cash drawers from the following suppliers:

Cash drawers	Number
NCR	7052-K657™
M-S Cash Drawer Corp.	EP-125 K series™, EP-127, EP-102™
APG Cash Drawer	Model 322™
Indiana Cash Drawer	Model SLD™

Power supply and power cords

Other suppliers may use different part numbers.

Item	Type	Kit Number
60-watt power supply with attached cable to printer and U.S. power supply cord		TPG-K330
60-watt power supply, attached cable		TPG-K301
Power supply cord (to outlet)	United States	TPG-K320
	United Kingdom	TPG-K322
	International (with plug)	TPG-K326

Communication cables

Other suppliers may use different part numbers.

Item	Length	Kit Number
RS-232C 9-pin female (printer) to 9-pin female (ferrite-host)	(3 meters~9.8 feet)	TPG-K340 (189-1077857)
USB A male 2.0 to B male 2.0	(2 meters~6 feet)	TPG-F345 (115-005-01)
Ethernet		Not available

Forms specifications

The A760 prints on single- or multiple-part forms in the slip station (up to five-part forms). Forms and slips must meet the following requirements:

- Front insertion (minimum):
51 mm (2.00") wide
68 mm (2.68") long
- Side insertion (minimum):
203 mm (8.0") wide
51 mm (2.0") long
- Single-ply forms should be on paper that is greater than 15 pounds

- Multiple-part forms (up to five parts) should be no thicker than 0.40 mm (0.016") and a minimum thickness of 0.08 mm (0.003").

Important: Do not use forms containing holes along the top or right edge.

Slip forms - recommendations

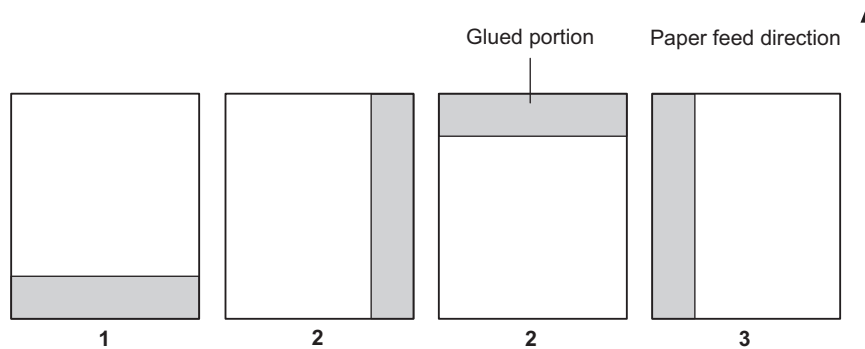

The slip form should be flat and void of curls or wrinkles, especially at the top.

- Considerations for glued edges on slip paper:
 - a No glue on bottom edge (1).

- b Right or top edge (2): Paper feeding and insertion are affected by gluing method, length of edge, and quality of glue used.
- c Left edge or wide slip paper (3): Skewing may occur.

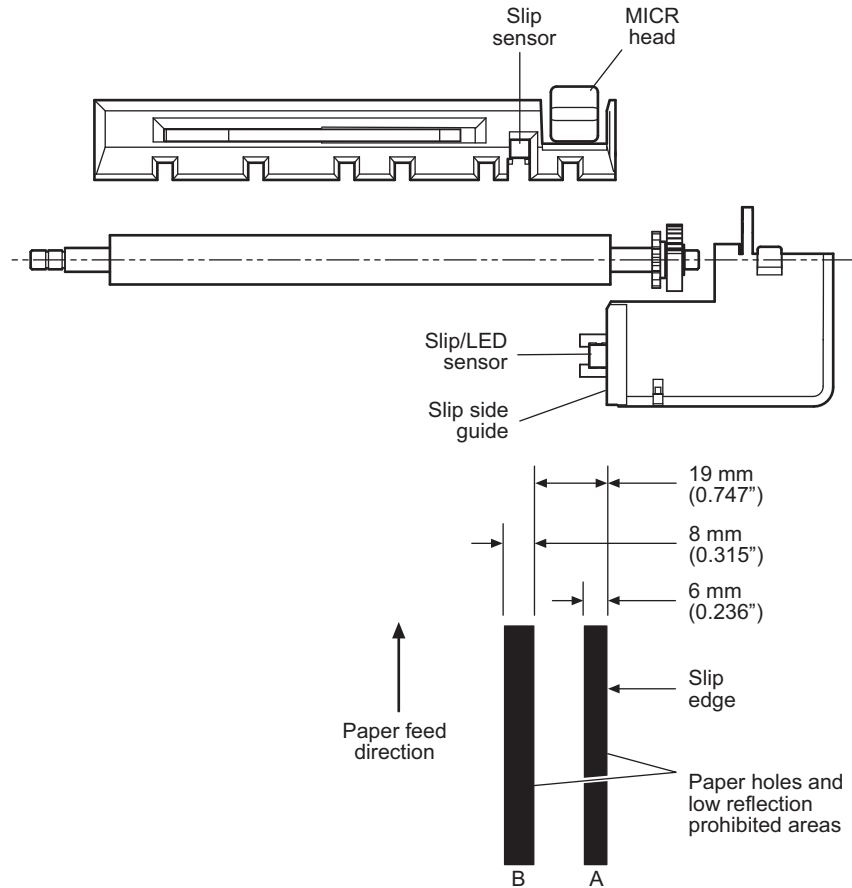

The Slip/LED sensors use a reflective photo sensor.

- Do not use paper that has holes or is translucent at the Slip/LED sensor location. (See “A” in above illustration.)

- Do not use paper that has holes on dark areas with low reflection (less than 60% reflection) at the slip sensor location. (See “B” in above illustration.)
- Thin paper should be used between the top and bottom sheets of multi-ply paper. Thick paper reduces the copy capability.

Check specifications

Check specifications for paper are defined by American Standards ANSI X9.13 and ANSI X9.18, and International Standard ISO 1004.

- Minimum check size: 70 mm (2.75") wide x 152 mm (6.00") long
- Maximum check size: 95 mm (3.75") wide x 222 mm (8.75") long

MICR reader – additional information

- The check must be flat and void of curls, folds, or wrinkles (especially at the edges). Wrinkled checks may rub against the ribbon causing them to become ink-stained.
- Checks must be void of clips or staples. Paper jams, MICR read errors, and/or MICR head damage could occur.
- Immediately release the check once the printer starts to feed it. Failure to release the check could skew it, causing paper jams and MICR read errors.

Ordering ribbon cassettes

To order ribbon cassettes, contact your sales representative or order from CognitiveTPG at the following toll free number: 1 (800) 732-8950, or go to the website at www.cognitivetpg.com.

Stock numbers: A152-0041 (purple ribbon cassette -- 5 million character life) -- Qty. 6

A152-0042 (black ribbon cassette—5 million character life) – Qty. 6

A152-0043 (purple long life ribbon cassette—7 million character life) – Qty. 6

Ordering extended slip tables

Contact a sales representative to order slip tables. The numbers listed below are for reference only. Suppliers may use other numbers.

- Extended slip table (standard) A760–K280
- Extended slip table (short) A760–K281

Documentation, LogoEZ® utility, Receiptware® marketing software

Please visit www.cognitivetpg.com to download the following documentation:

[A760 ColorPOS® User Guide Programming Supplement*](#)

A760 ColorPOS® Service Guide (CognitiveTPG certified service technicians only)

[A760 ColorPOS® Setup Guide*](#)

[CognitiveTPG LogoEZ® colorization utility*](#)

[CognitiveTPG Receiptware® marketing software*](#)

