

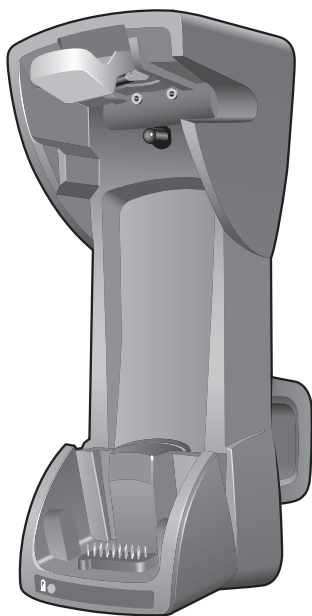

VCD9000 Cradle

For MC9000 Mobile Computers

Quick Reference Guide



© 2007 MOTOROLA, INC. All rights reserved.

Motorola reserves the right to make changes to any product to improve reliability, function, or design.

Motorola does not assume any product liability arising out of, or in connection with, the application or use of any product, circuit, or application described herein.

No license is granted, either expressly or by implication, estoppel, or otherwise under any patent right or patent, covering or relating to any combination, system, apparatus, machine, material, method, or process in which Motorola products might be used. An implied license exists only for equipment, circuits, and subsystems contained in Motorola products.

MOTOROLA, the Stylized M Logo and Symbol and the Symbol logo are registered trademarks of Motorola, Inc. Other product names mentioned in this manual may be trademarks or registered trademarks of their respective companies and are hereby acknowledged.

Motorola, Inc.
One Motorola Plaza
Holtsville, N.Y. 11742-1300
<http://www.symbol.com>

Warranty

For the complete Motorola hardware product warranty statement, go to:
<http://www.symbol.com/warranty>.

Patents

This product is covered by one or more patents. For patent information go to:
<http://www.symbol.com/patents>.

Introduction

This guide describes how to install and use a VCD9000 vehicle cradle with a Symbol MC9000 Series mobile computer.

Install the VCD9000 into the cab of the vehicle. Once installed, the cradle holds the mobile computer securely in place. It also:

- provides power for operating the mobile computer.
- provides a serial port for data communication between the mobile computer and an external device (e.g., a printer).
- re-charges the mobile computer's battery.
- re-charges a spare battery.

The vehicle's 12 V or 24 V electrical system powers the cradle. The operating voltage range is 9 V to 32 V and requires a maximum current of 4A.

About This Guide

Specific topics in this guide include:

- [Requirements on page 4](#)
- [Parts on page 5](#)
- [Cradle Mounting on page 7](#)
- [Power Connection on page 9](#)
- [Serial Device Connection on page 11](#)
- [Mobile Computer Insertion and Removal on page 12](#)
- [Mobile Computer Battery Charging on page 13](#)
- [Spare Battery Insertion and Removal on page 14](#)
- [Spare Battery Charging on page 14](#)
- [LED Indicators on page 15](#)
- [Care and Cleaning on page 15](#)
- [Troubleshooting on page 16](#)
- [Regulatory Information on page 17](#)
- [Service Information on the back cover.](#)

For detailed information on MC9000 Series mobile computers, refer to the mobile computer's *Quick Start Guide* or *Product Reference Guide*.

Requirements

- for mounting:
 - four 8-32 X 1" long screws with locking washers (provided as part of the cradle)
 - four #8 washers recommended
 - a drill with a #6 drill bit (0.204")
- for power connection:
 - power input cable (provided)
 - UL-listed in-line fuse rated 4A or 5A (both included), must be used if not connecting to vehicle's fuse panel.

For 12 V operation use UL-listed 5A fuse (included).

For 24 V operation use UL-listed 4A fuse (included).



WARNING! For continued protection against risk of fire, replace only with same type and rating of fuse according to the input voltage used.

- In-line fuse holder (included), must be used if not connecting to vehicle's fuse panel.
- for serial connection:
 - DB9 female serial cable (some external devices require a null modem cable)
- for communication:
 - an MC9000 Series mobile computer
 - setup of mobile computer and external device (as determined by the application used).

Parts

FRONT

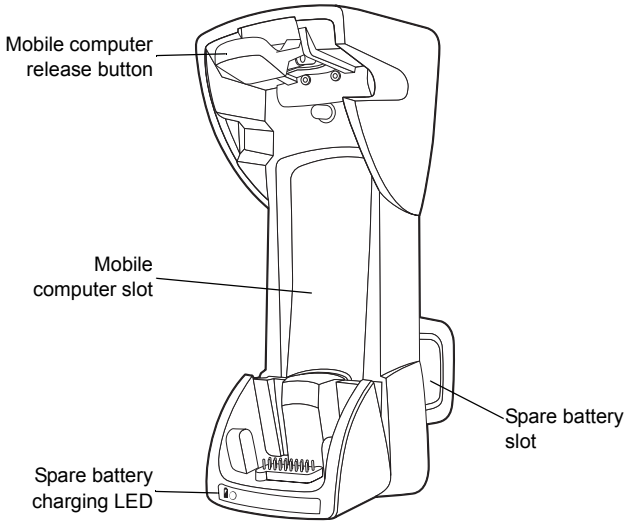

BACK

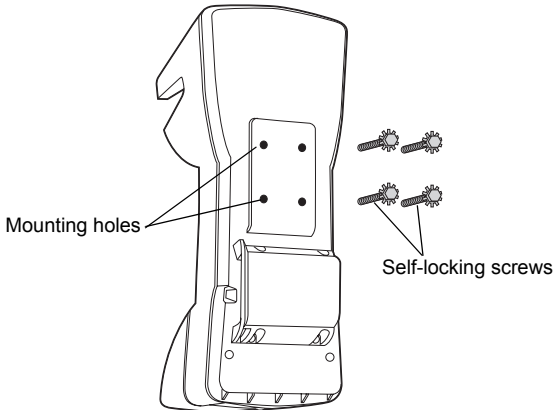

BOTTOM

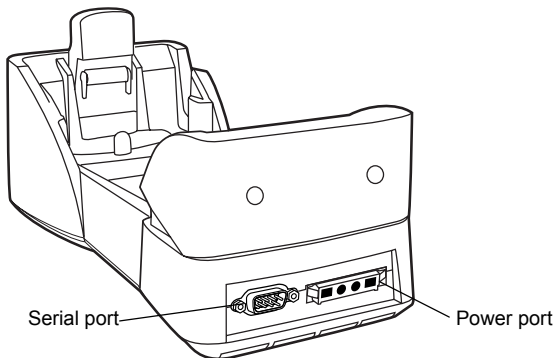

There are two connection ports on the bottom of the cradle:

Ports	Function
Serial	Standard RS-232 port for direct connection to a serial device using a serial cable.
Power	Connects to vehicle power using the power input cable.



CAUTION ROAD SAFETY - Do not use the mobile computer while driving. Park the vehicle first. Ensure the mobile computer is fully inserted in the cradle. Do not place it on the seat or where it can break loose in a collision or sudden stop. Improper insertion can result in property damage or personal injury. Remember: Safety comes first.

Cradle Mounting



CAUTION Only mount the Vehicle Cradle in a vertical position with the release button at the top or in a horizontal position with the mobile computer display facing up. Never mount the Vehicle Cradle on the side or upside down or on a wall that can be subject to impact or collision of greater than 40Gs, in accordance with SAE J1455 Section 4.10.3.5.

1. If not using a mounting bracket or mounting device compatible with the VCD9000, prepare the mounting surface to accept four 8-32 X 1" long self-locking screws, using a copy of the mounting template below. Drill four holes (0.204" diameter) with a #6 drill bit.

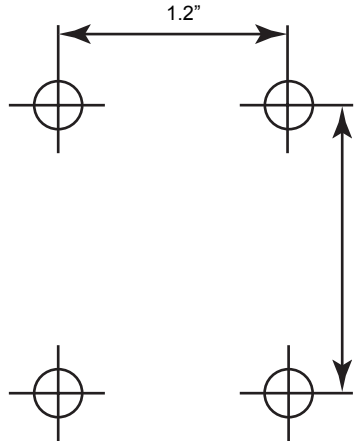

2. Remove the four self-locking screws from the back of the cradle.

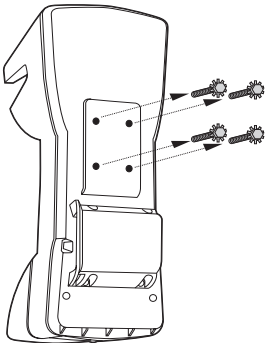

3. Place the back of the cradle on the mounting bracket or other mounting device/surface, with the four holes in the back of the cradle aligned with the four holes in the mounting surface.
4. Insert the four self-locking screws through the holes in the mounting surface, into the back of the cradle.

Symbol recommends using #8 washers to protect the mounting surface.

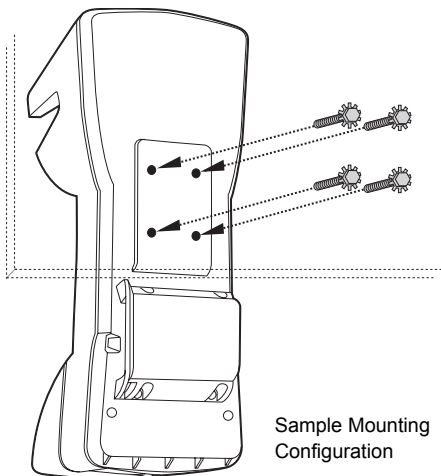

CAUTION Do not install the cradle on or near an air bag cover plate or within an aerobic zone. Also, do not install it in a location that affects vehicle safety or driving ability.

Power Connection

Read the following instructions completely before beginning.



WARNING! A properly trained technician must perform the power connection. Improper connection can damage the vehicle or cradle.

To connect the cradle to power:

1. Locate the vehicle power source.



NOTE An accessory output in the vehicle's fuse panel is the ideal location for connecting the vehicle cradle power input cable. The vehicle cradle should be added to a circuit with a maximum load capacity for the cradle and the original circuit. Refer to the vehicle's owner's manual for identification of the circuit. If a fused output is not available, the cradle must be installed with the provided in-line fuse holder and UL-listed fuse (rated 4A for 24 V operation, 5A for 12 V operation). The fuse protects the vehicle from an electrical short on the power line to the cradle.

To use the cradle to charge the mobile computer and spare battery, shut off the vehicle's ignition, then connect the cradle to unswitched power.

2. Route the power input cable from the cradle's power port to the connection point for the vehicle's power source.



CAUTION The means of routing and securing the power input cable from the cradle through to the vehicle power source is extremely important. Hazards associated with improper wiring can be severe. To avoid unintentional contact between the wire and any sharp edges, provide the cable with proper bushings and clamping where it passes through openings. If the wire is subject to sharp surfaces and excess engine vibration, the wiring harness insulation can wear away, causing a short between the bare wire and chassis. This can start a fire.

3. When using the supplied in-line fuse holder (which must be used if not connecting to the vehicle's fuse panel):
 - a. Ensure the fuse holder contains a UL-listed fuse (rated 4A for 24 V operation, 5A for 12 V operation).

- b. Splice the fuse holder to the end of the red V+ wire, as shown below. Make the distance from the fuse to the power connection point as short as possible.

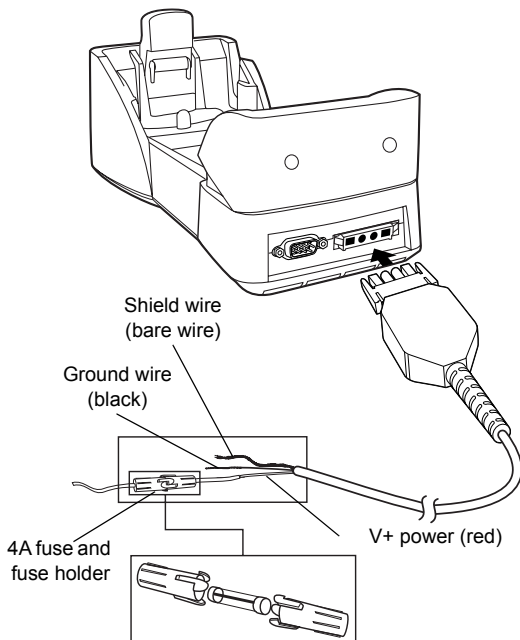

4. Prepare the cable termination.

- a. Red wire: connect to a +12/24 V vehicle power source.
- b. Black wire and shield wire: connect to vehicle ground wire or chassis ground.

✓ **NOTE** How the cable terminates depends on the vehicle. If the vehicle has a power output connector, attach a mating connector to the end of the power cable. You may be able to connect to a fuse panel with a simple blade terminal or commercially available connector. Consult the vehicle owner's manual for information on how to access the vehicle's power supply.

5. Connect the power input cable to the power port on the cradle.

To see if the cradle has power, insert the mobile computer. The mobile computer battery charging LED blinks amber to indicate charging, then turns solid amber when the battery is completely charged. See [LED Indicators on page 15](#) for other indications.

Serial Device Connection

When you insert the MC9000 into the cradle, the mobile computer's serial port connects to the cradle's serial port. The mobile computer can then use the cradle's serial port to communicate with an external device.

To provide serial communication between the mobile computer and a serial device, connect one end of the 9-pin serial cable to the serial port on the cradle, and the other end to the serial port on the serial device.

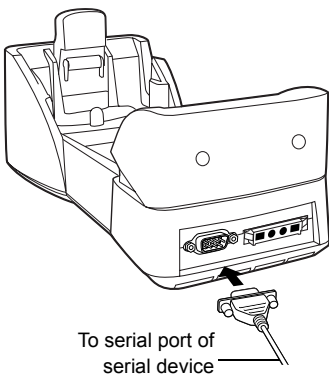

NOTE Some external devices may require a null modem cable.

To begin communication:

1. Insert the mobile computer into the cradle.
2. Initiate communication on the mobile computer, as determined by the application used.



CAUTION Removing the mobile computer during communication disrupts communication between the mobile computer and the attached device.

Mobile Computer Insertion and Removal

To insert the mobile computer into the cradle, place the bottom of the mobile computer into the bottom of the cradle, then press the mobile computer back into the cradle until the release button locks it in place.

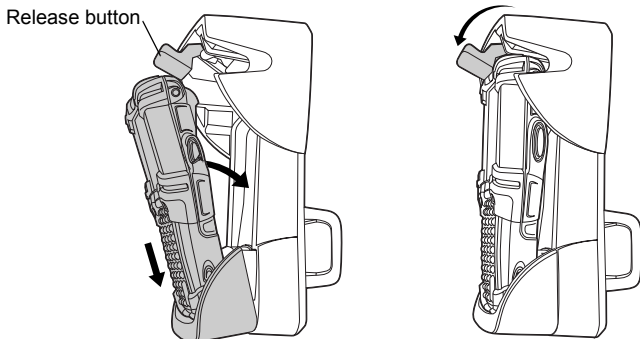

CAUTION Ensure the mobile computer is fully inserted into the cradle. Improper insertion can result in property damage or personal injury. Do not use the product while driving.

To remove the mobile computer from the cradle, lift the release button, then lift the mobile computer from the cradle.

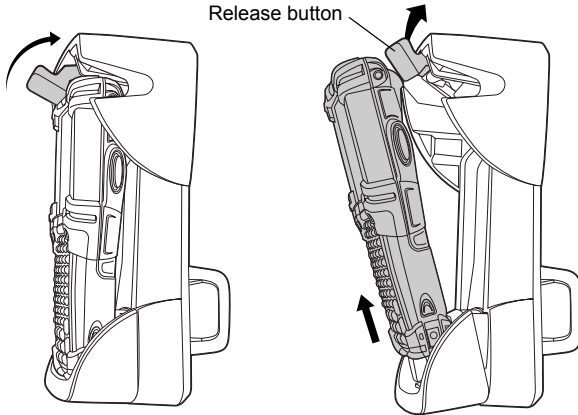

Mobile Computer Battery Charging

1. Ensure the cradle is connected to a power source. See [Power Connection on page 9](#).
2. Insert the mobile computer into the cradle. See [Mobile Computer Insertion and Removal on page 12](#).

The mobile computer starts charging when inserted. This does not deplete the vehicle battery significantly.

The mobile computer battery charging LED blinks amber to indicate charging, then turns solid amber when the battery is completely charged. The battery charges in approximately four hours. See [LED Indicators on page 15](#) for other indications.

Spare Battery Insertion and Removal

To insert a spare battery:

1. Insert the battery into the spare battery charging slot in the back of the cradle as shown.

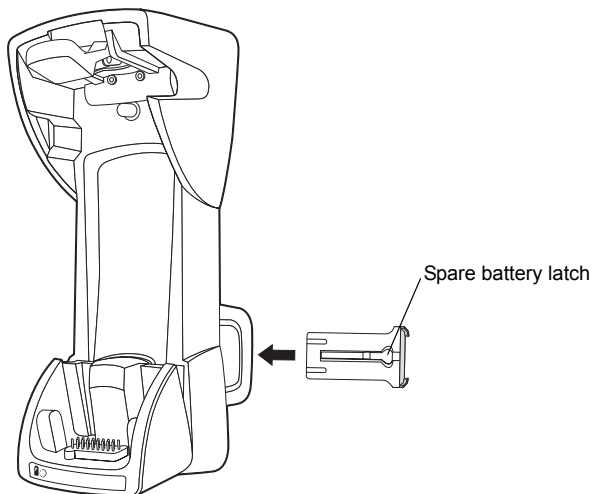

2. Push the battery in. Listen for the click that signifies the battery's latch has locked the battery into place.

To remove the spare battery, press in the battery latch, then remove the battery from the spare battery slot.

Spare Battery Charging

1. Ensure the cradle is connected to a power source. See [Power Connection on page 9](#).
2. Insert the spare battery into the cradle. See [Spare Battery Insertion and Removal on page 14](#).

The spare battery charging LED blinks amber to indicate charging, then turns solid amber when the battery is completely charged. The battery charges in approximately four hours. See [LED Indicators](#) for other indications.

LED Indicators

Cradle LED	Indication
Mobile Computer Battery Charging LED	
Off	Mobile computer is not in cradle; mobile computer is not inserted correctly; cradle is not powered.
Fast Blinking Amber	Error in charging; check placement of mobile computer.
Slow Blinking Amber	Mobile computer is charging.
Solid Amber	Charging complete.
⏏ Spare Battery Charging LED (on Cradle)	
Off	No spare battery in slot; spare battery is not inserted correctly; cradle is not powered.
Fast Blinking Amber	Error in charging; check placement of spare battery.
Slow Blinking Amber	Spare battery is charging.
Solid Amber	Charging is complete.

Care and Cleaning

Avoid getting oils, grease, or gasoline on the cradle, and do not let debris gather in the bottom of the cradle slot. When necessary, clean the cradle with a mild cleaner. If necessary, contact Symbol for advice on whether to use a particular cleaner.

Troubleshooting

Symptom	Possible Cause	Action
Mobile computer battery charging LED does not light.	Cradle is not receiving power.	Ensure the power input cable is securely connected to the cradle's power port.
Mobile computer's battery is not recharging.	Mobile computer was removed from the cradle too soon.	Replace the mobile computer in the cradle. If the mobile computer's battery pack is fully depleted, it can take four hours to fully recharge the battery.
	Battery is faulty.	Replace the battery.
	Mobile computer was not placed correctly in the cradle.	Remove the mobile computer from the cradle, and re-insert correctly. If the battery still does not charge, contact Customer Support. The mobile computer battery charging LED blinks amber when the mobile computer is correctly inserted and is charging.
No data was transmitted, or transmitted data was incomplete.	Mobile computer was removed from the cradle during communication.	Replace the mobile computer in the cradle and retransmit.
	The external device required a null modem cable, which was not used.	Retransmit using a null modem cable.
	Incorrect cable configuration.	See the system administrator.

Regulatory Information

This device is approved under the Symbol Technologies brand; Symbol Technologies, Inc., is the Enterprise Mobility business of Motorola, Inc. ("Motorola").

All Symbol devices are designed to be compliant with rules and regulations in locations they are sold and will be labeled as required.

Any changes or modifications to Symbol equipment, not expressly approved by Symbol, could void the user's authority to operate the equipment.

Radio Frequency Interference Requirements-FCC



Note: This equipment has been tested and found to comply with the limits for a Class B digital device, pursuant to Part 15 of the FCC rules. These limits are designed to provide reasonable protection against harmful interference in a residential installation. This equipment generates, uses and can radiate radio frequency energy and, if not installed and used in accordance with the instructions, may cause harmful interference to radio communications. However there is no guarantee that interference will not occur in a particular installation. If this equipment does cause harmful interference to radio or television reception, which can be determined by turning the equipment off and on, the user is encouraged to try to correct the interference by one or more of the following measures:

- Reorient or relocate the receiving antenna
- Increase the separation between the equipment and receiver
- Connect the equipment into an outlet on a circuit different from that to which the receiver is connected
- Consult the dealer or an experienced radio/TV technician for help.

Radio Frequency Interference Requirements - FCC

This device complies with Part 15 of the FCC Rules. Operation is subject to the following two conditions: (1) this device may not cause harmful interference, and (2) this device must accept any interference received, including interference that may cause undesired operation.

Radio Frequency Interference Requirements - Canada

This Class B digital apparatus complies with Canadian ICES-003.

Cet appareil numérique de la classe B est conforme à la norme NMB-003 du Canada.

CE Marking and European Economic Area (EEA)

Statement of Compliance

Symbol Technologies, Inc., hereby, declares that this device is in compliance with all the applicable Directives, 89/336/EEC, 73/23/EEC, 95/54/EEC. A Declaration of Conformity may be obtained from <http://www2.symbol.com/doc/>.

Safety Instructions

An air bag inflates with great force. DO NOT place objects, including either installed or portable wireless equipment, in the area over the air bag or in the air bag deployment area. If in-vehicle wireless equipment is improperly installed and the air bag inflates, serious injury could result.

Position your device within easy reach. Be able to access your device without removing your eyes from the road.

Do not take notes or use the device while driving. Jotting down a "to do" list or flipping through your address book takes attention away from your primary responsibility, driving safely.



Waste Electrical and Electronic Equipment

English: For EU Customers: All products at the end of their life must be returned to Motorola for recycling. For information on how to return product, please go to: http://www.symbol.com/environmental_compliance.

Bulgarian: За клиенти от ЕС: След края на полезния им живот всички продукти трябва да се връщат на Motorola за рециклиране. За информация относно връщането на продукти, моля отидете на адрес: <http://www.symbol.com/weeelink>.

Čeština: Pro zákazníky z EU: Všechny produkty je nutné po skončení jejich životnosti vrátit společnosti Motorola k recyklaci. Informace o způsobu vrácení produktu najdete na webové stránce: http://www.symbol.com/environmental_compliance.

Dansk: Til kunder i EU: Alle produkter skal returneres til Motorola til recirkulering, når de er udtjent. Læs oplysningerne om returnering af produkter på: http://www.symbol.com/environmental_compliance.

Deutsch: Für Kunden innerhalb der EU: Alle Produkte müssen am Ende ihrer Lebensdauer zum Recycling an Motorola zurückgesandt werden. Informationen zur Rücksendung von Produkten finden Sie unter http://www.symbol.com/environmental_compliance.

Eesti: EL klientidele: kõik tooted tuleb nende eluea lõppedes tagastada taaskasutamise eesmärgil Motorola'ile. Lisainformatsiooni saamiseks toote tagastamise kohta külastage palun aadressi: http://www.symbol.com/environmental_compliance.

Español: Para clientes en la Unión Europea: todos los productos deberán entregarse a Motorola al final de su ciclo de vida para que sean reciclados. Si desea más información sobre cómo devolver un producto, visite: http://www.symbol.com/environmental_compliance.

Ελληνικά: Για πελάτες στην Ε.Ε.: Όλα τα προϊόντα, στο τέλος της διάρκειας ζωής τους, πρέπει να επιστρέφονται στην Motorola για ανακύκλωση. Για περισσότερες πληροφορίες σχετικά με την επιστροφή ενός προϊόντος, επισκεφθείτε τη διεύθυνση http://www.symbol.com/environmental_compliance στο Διαδίκτυο.

Français : Clients de l'Union Européenne : Tous les produits en fin de cycle de vie doivent être retournés à Motorola pour recyclage. Pour de plus amples informations sur le retour de produits, consultez : http://www.symbol.com/environmental_compliance.

Italiano: per i clienti dell'UE: tutti i prodotti che sono giunti al termine del rispettivo ciclo di vita devono essere restituiti a Motorola al fine di consentirne il riciclaggio. Per informazioni sulle modalità di restituzione, visitare il seguente sito Web:
http://www.symbol.com/environmental_compliance.

Latviešu: ES klientiem: visi produkti pēc to kalpošanas mūža beigām ir jānogādā atpakaļ Symbol otrreizējai pārstrādei. Lai iegūtu informāciju par produktu nogādāšanu Motorola, lūdzu, skatiet: http://www.symbol.com/environmental_compliance.

Lietuvių: ES vartotojams: visi gaminiai, pasibaigus jų eksploatacijos laikui, turi būti gražinti utilizuoti į kompaniją „Motorola“. Daugiau informacijos, kaip gražinti gaminį, rasite: http://www.symbol.com/environmental_compliance.

Magyar: Az EU-ban vásárlóknak: Minden tönkrement termékét a Motorola vállalathoz kell eljuttatni újrahasznosítás céljából. A termék visszajuttatásának módjával kapcsolatos tudnivalóért látogasson el a http://www.symbol.com/environmental_compliance weboldalra.

Malti: Għal klijenti fl-UE: il-prodotti kollha li jkunu waslu fl-aħħar tal-hajja ta' l-użu tagħhom, iridu jiġu rritornati għand Motorola għar-riciklaġġ. Għal aktar taġrif dwar kif għandek tirritorna l-prodott, jekk jogħġbok żur: http://www.symbol.com/environmental_compliance.

Nederlands: Voor klanten in de EU: alle producten dienen aan het einde van hun levensduur naar Motorola te worden teruggezonden voor recycling. Raadpleeg http://www.symbol.com/environmental_compliance voor meer informatie over het terugzenden van producten.

Polski: Klienci z obszaru Unii Europejskiej: Produkty wycofane z eksploatacji należy zwrócić do firmy Motorola w celu ich utylizacji. Informacje na temat zwrotu produktów znajdują się na stronie internetowej http://www.symbol.com/environmental_compliance.

Português: Para clientes da UE: todos os produtos no fim de vida devem ser devolvidos à Motorola para reciclagem. Para obter informações sobre como devolver o produto, visite: http://www.symbol.com/environmental_compliance.

Românesc: Pentru clienții din UE: Toate produsele, la sfârșitul duratei lor de funcționare, trebuie returnate la Motorola pentru reciclare. Pentru informații despre returnarea produsului, accesați: <http://www.symbol.com/weelink>.

Slovenski: Za kupce v EU: vsi izdelki se morajo po poteku življenjske dobe vrniti podjetju Motorola za reciklažo. Za informacije o vračilu izdelka obiščite: http://www.symbol.com/environmental_compliance.

Slovenčina: Pre zákazníkov z krajín EU: Všetky výrobky musia byť po uplynutí doby ich životnosti vrátené spoločnosti Motorola na recykláciu. Bližšie informácie o vrátení výrobkov nájdete na: http://www.symbol.com/environmental_compliance.

Suomi: Asiakkaat Euroopan unionin alueella: Kaikki tuotteet on palautettava kierrätettäväksi Motorola-yhtiöön, kun tuotetta ei enää käytetä. Lisätietoja tuotteen palauttamisesta on osoitteessa http://www.symbol.com/environmental_compliance.

Svenska: För kunder inom EU: Alla produkter som uppnått sin livslängd måste returneras till Motorola för återvinning. Information om hur du returnerar produkten finns på http://www.symbol.com/environmental_compliance.

Service Information

If you have a problem using the equipment, contact your facility's Technical or Systems Support. If there is a problem with the equipment, they will contact the Motorola Enterprise Mobility Support at: <http://www.symbol.com/contactsupport>.

For the latest version of this guide go to: <http://www.symbol.com/manuals>.



MOTOROLA

Motorola, Inc.
One Motorola Plaza
Holtsville, New York 11742, USA
1-800-927-9626
<http://www.symbol.com>

MOTOROLA and the Stylized M Logo and Symbol and the Symbol logo are registered in the U.S. Patent and Trademark Office. All other product or service names are the property of their respective owners. © Motorola, Inc. 2007



72-63295-03 Revision A - September 2007