

Q R G  
R P 1 0 0 0

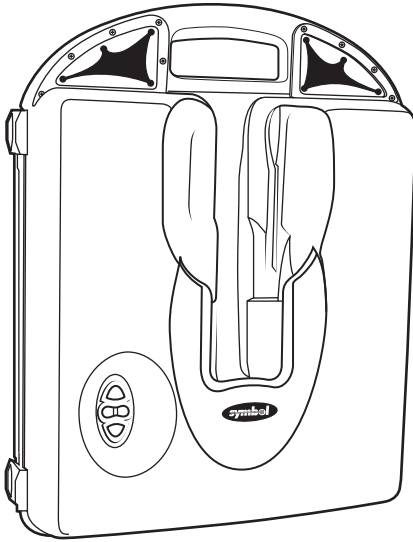

**symbol®**



© 2002 **SYMBOL TECHNOLOGIES, INC.** All rights reserved.

Symbol reserves the right to make changes to any product to improve reliability, function, or design.

Symbol does not assume any product liability arising out of, or in connection with, the application or use of any product, circuit, or application described herein.

No license is granted, either expressly or by implication, estoppel, or otherwise under any patent right or patent, covering or relating to any combination, system, apparatus, machine, material, method, or process in which Symbol products might be used. An implied license exists only for equipment, circuits, and subsystems contained in Symbol products.

Symbol and the Symbol logo are registered trademarks of Symbol Technologies, Inc. Other product names mentioned in this manual may be trademarks or registered trademarks of their respective companies and are hereby acknowledged.

Symbol Technologies, Inc.  
One Symbol Plaza  
Holtsville, N.Y. 11742-1300  
<http://www.symbol.com>

## Introduction

The RP 1000 printer is a portable, rugged, full-page dot matrix printer that houses a PDT 8000 or PDT 8100 terminal. With an easy one-step insertion, the terminal snaps into place in the RP 1000 for direct printing in the cab of a truck, or carried into a remote receiving area.

## About This Guide

This guide covers the procedures for the basic set-up and use of the printer. Specific topics covered include:

- *Parts of the Printer on page 2*
- *Power Accessories on page 4*
- *Getting Started on page 4*
- *Installing the Battery on page 5*
- *Installing the AC Power Adapter on page 6*
- *Installing the Cigarette Lighter Adapter on page 8*
- *Charging the Battery on page 8*
- *Installing the Print Cartridge on page 9*
- *Loading Paper on page 9*
- *Controls and Indicators on page 13*
- *Configuration Self-Test on page 14*
- *Care and Maintenance on page 15*
- *Supplies on page 15*
- *Regulatory Information on page 16*
- *Warranty on page 17*
- *Service Information on backcover.*

For detailed information on portable terminals, see the *Quick Reference Guide* or *Product Reference Guide* for the terminal.

## Parts of the Printer

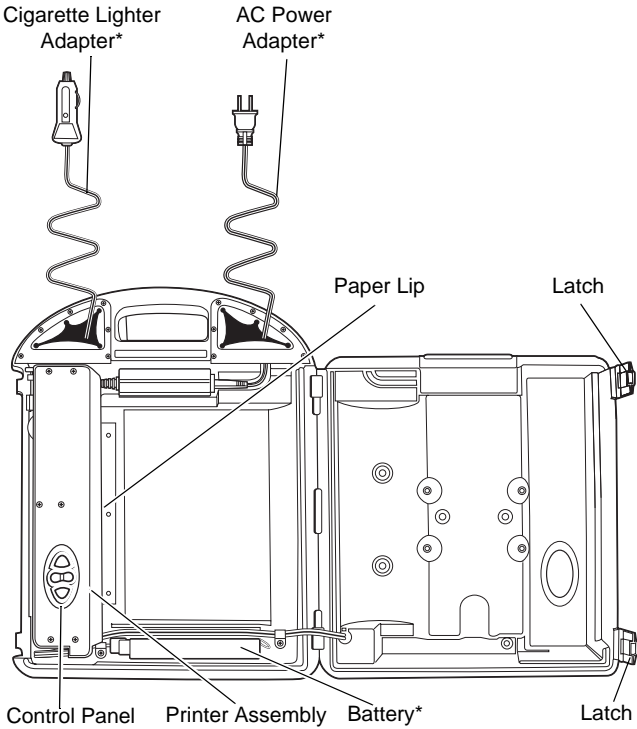

\* Optional Accessory

# Q u i c k R e f e r e n c e

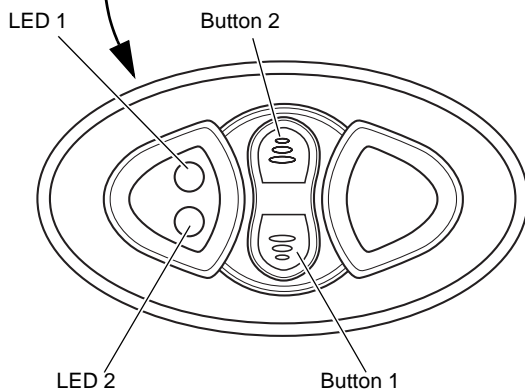
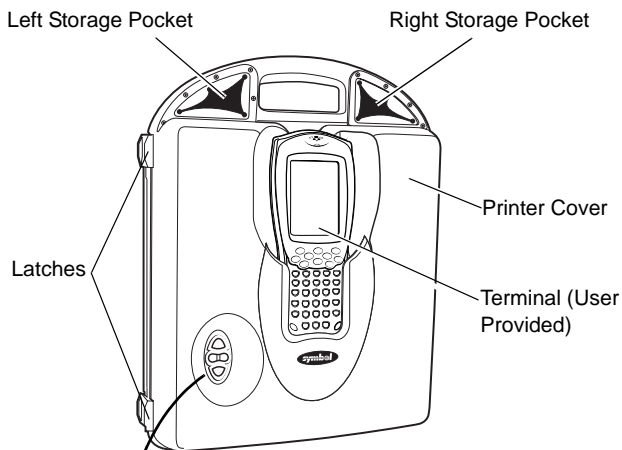



## **Power Accessories**

Any of the optional accessories can be used to supply power to the RP 1000 printer:

- 12 volt Nickel Metal Hydride battery
- AC power adapter
- cigarette lighter adapter.

**Note:** If the battery is used, then either the AC power adapter or the cigarette lighter adapter must be used to charge the battery.

## **Getting Started**

Before using the RP 1000, perform the following basic set up procedures:

- installing the battery
- installing the AC power adapter
- installing the cigarette lighter adapter
- charging the battery
- installing the print cartridge
- loading paper.

## Installing the Battery

1. Open the cover.
2. Place the battery in the battery well as shown.

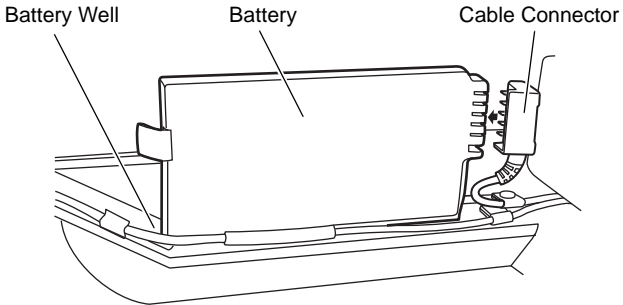

3. Connect the cable connector to the battery.
4. Install the battery strap.

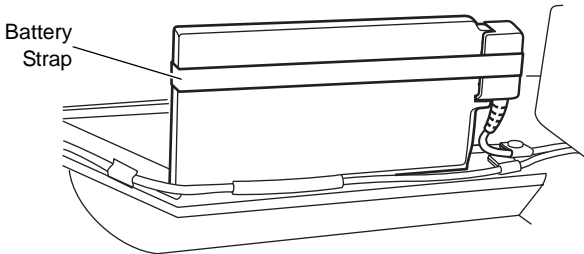

5. Close the cover.
6. Charge the battery. Refer to [Charging the Battery on page 8](#).

## Installing the AC Power Adapter

1. Open the cover.
2. Depress the locking lever to open the print mechanism.

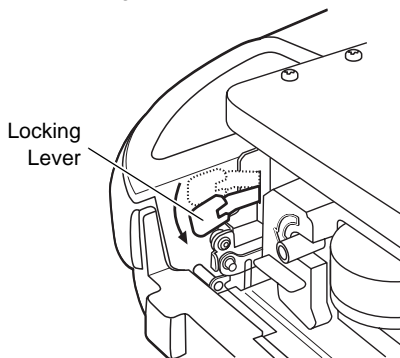

3. Flip open the print mechanism.

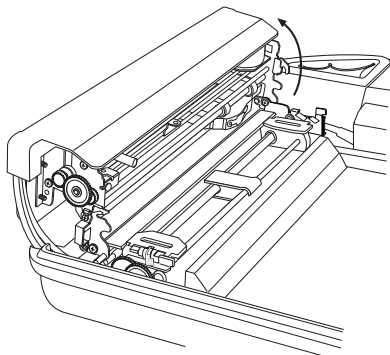



## Q u i c k R e f e r e n c e

4. Feed the transformer connector through the access hole and into the left storage pocket.

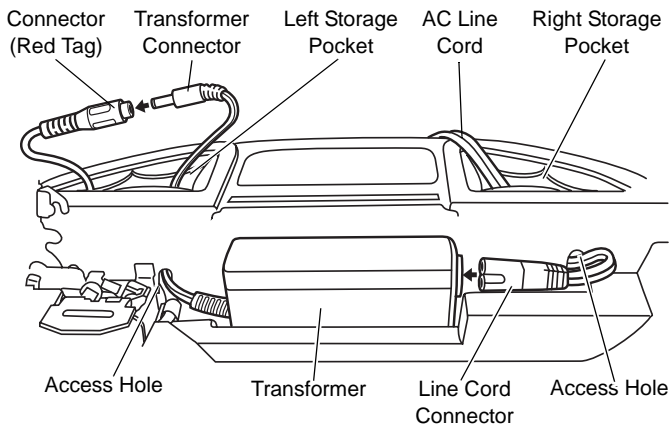

5. Connect the transformer connector to the connector with the red tag.
6. Place the connectors into the left storage pocket.
7. Place the print mechanism back to its original position.
8. Feed the AC line cord connector into the right storage pocket and through the access hole.
9. Plug the cable into the transformer.
10. Close the cover.

## Installing the Cigarette Lighter Adapter

Connect the cigarette lighter cable adapter to the connector with the white tag in the left storage pocket.

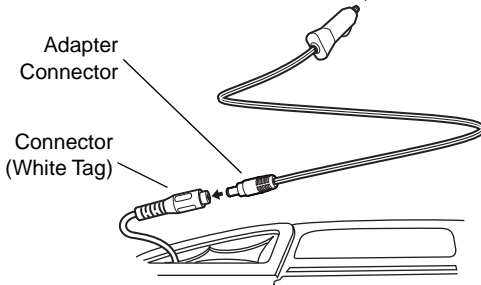

## Charging the Battery

**Note:** When a battery is installed, the RP 1000 sounds a beep every 30 seconds when the battery is low.

To charge the battery, plug the AC power cord into a wall outlet or the cigarette lighter adapter into the vehicle's cigarette lighter. The RP 1000 battery completely charges in approximately 3 to 4 hours and 4 to 5 hours with the terminal installed in the printer.

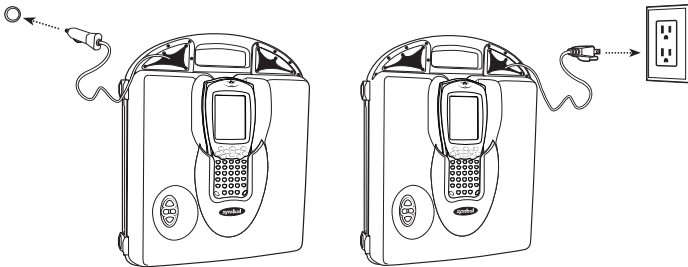

## Installing the Print Cartridge

The RP 1000 ships without the print cartridge installed. To install the print cartridge:

1. Remove the print cartridge from the package.
2. Open the printer cover.
3. Hold the print cartridge by the flat handle.
4. Insert the print cartridge on the print head.
5. Turn knob in direction of arrow several times to fully seat ribbon.

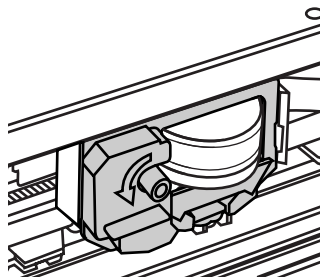
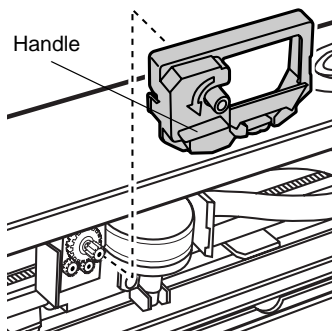

## Loading Paper

The RP 1000 can hold the following number of form sheets depending upon the number of parts in the form.

| Form Parts | Maximum Number of Sheets |
|------------|--------------------------|
| 1          | 200                      |
| 2          | 90                       |
| 3          | 60                       |
| 4          | 50                       |

---

Caution: Inserting more paper will result in paper jams.

---

1. Open the two latches on the side of the printer cover.
2. Lift the cover to the fully open position.
3. Depress the locking lever to open the print mechanism.

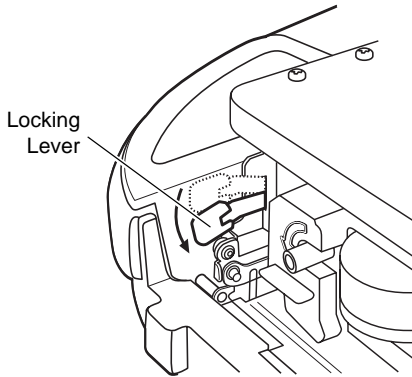

4. Flip open the print mechanism.

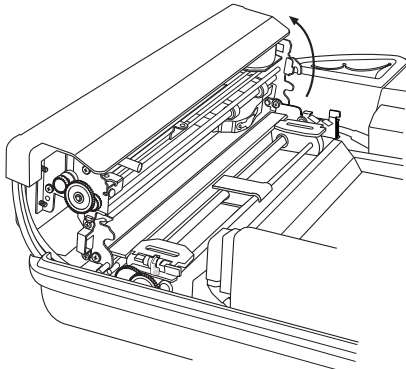

## Q u i c k R e f e r e n c e

5. Lift the two tractor feed clips.

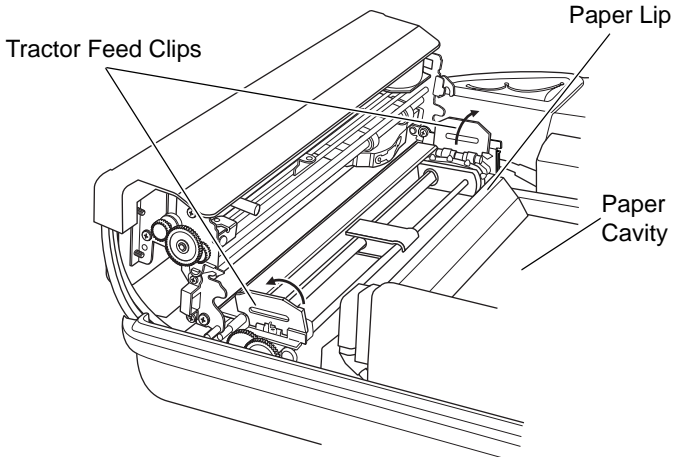

6. Fold the stack of paper in half with the short sides together and the top of the form coming out from inside fold.
7. Place the paper into the printer cavity with bottom edges under the paper lip in bottom of cavity.
8. Feed the top of the form from the inside of fold through the tractor feed pins and to the outside edge of the printer.
9. Align the holes in the paper with the studs in the tractor feed wheel.

10. Close the tractor feed clips.

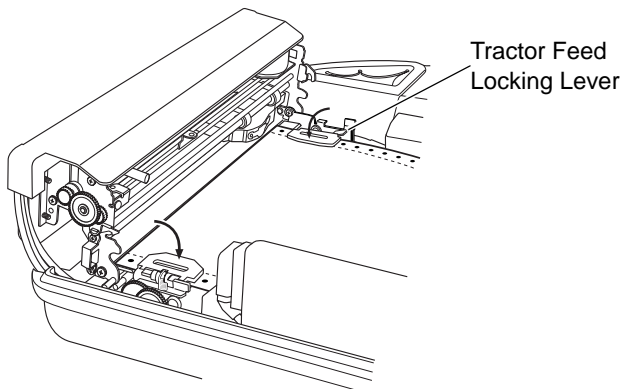

11. The left tractor feed is adjustable. Lift the locking lever to release the tractor feed.
12. Ensure that the paper is taught in order for the paper to feed properly.
13. Press down on the tractor feed locking lever to lock the tractor feed in place.
14. Close the print mechanism.
15. Close the printer cover.

### **Setting the Top of a Form**

1. Press Button 1 to turn on the printer.
2. Position the paper by pressing Button 1 until the edge of the paper is at the edge of the case. Press Button 2 to back feed the paper, if needed.
3. Turn the printer off by simultaneously pressing Button 1 and Button 2.
4. Press Button 1 to turn the printer on. The top of the form is automatically set.

## Tearing the Paper

1. Set the paper to the top of a form.
2. Grab one side of the paper at a leading edge and pull up.  
Once the paper tear is started at the perforation, finish with a swift pull upward and away.

## Controls and Indicators

### Controls

| Function                         | Action                                      |
|----------------------------------|---|
| Line Feed                        | Press Button 1 once                         |
| 5 Line Feeds                     | Press & hold Button 1                       |
| Form Feed                        | Press & hold Button 1 then release          |
| Self Test                        | Press & hold Button 1 until printing starts |
| Clear "Out of Paper"             | Press Button 1                              |
| Stop Print or Pause/Clear Buffer | Press Button 1                              |
| Back Feed                        | Press Button 2                              |

### LED Indications

| LED 1                 | Status                                  |
|-----------------------|---|
| Solid Red             | Charging in progress                    |
| Red Flash Slow        | Low temperature or battery disconnected |
| Red Flash Fast        | High temperature                        |
| Red/Orange Flash Slow | Low voltage                             |
| Red/Orange Flash Fast | High Voltage                            |
| Orange Flash Slow     | Time out                                |
| Orange Flash Fast     | Internal Error                          |
| Solid Green           | Charge completed                        |



| LED 2       | Status   |
|-------------|----------|
| Solid Green | Power on |

## Audio Indications

| Audio                      | Status                         |
|----------------------------|--------------------------------|
| Beeping with LEDs flashing | Head jam. Check for paper jam. |
| 5 double beeps             | Out of paper                   |
| 3 beeps                    | Low battery                    |

## Configuration Self-Test

To establish communication between the computer and RP 1000 printer, check the RP 1000's protocol and set the computer's to match it. Print a configuration self-test by holding down button 1 for a few seconds. A sample default configuration is shown below.

```
Printer Configuration
Printer Type          8i Flash
Firmware Version     2.XX
Timeout              15S
Baud Rate            9600
Parity                None
Data Bits            8
Handshaking          Both
Beeper               On
Battery voltage       XX.XV - GOOD
Batt. Temperature    19C
Flash/RAM Memory     4/1 Mbit
Boot Version         2.06
Printhead Driver     1.04
Infrared Configuration
```



## Q u i c k R e f e r e n c e

|                 |          |
|-----------------|----------|
| Infrared        | IrDA     |
| Device Name     | 8i Flash |
| Device Nickname |          |
| IrDA Version    | 1.0-12   |
| Max IrDA Baud   | 115.2K   |

### Care and Maintenance

- Do not expose printer to temperatures over 70°C/158°F or under -40°C/-40°F.
- Use only approved power supplies or damage may result.
- Do not spill liquids on printer or immerse.
- Do not attempt to service this unit. Contact the Symbol Support Center.

### Supplies

Use only supplies certified by the Original Equipment Manufacturer (OEM). For OEM supplies, please contact the Symbol Customer Support Center.



## Regulatory Information

All Symbol devices are designed to be compliant with rules and regulations in locations they are sold and will be labeled as required.

Any changes or modifications to Symbol Technologies equipment, not expressly approved by Symbol Technologies, could void the user's authority to operate the equipment.

### Radio Frequency Interference Requirements

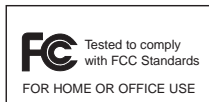

Note: This equipment has been tested and found to comply with the limits for a Class B digital device, pursuant to Part 15 of the FCC rules. These limits are designed to provide reasonable protection against harmful interference in a residential installation. This equipment generates, uses, and can radiate radio

frequency energy and, if not installed and used in accordance with the instructions, may cause harmful interference to radio communications. However there is no guarantee that interference will not occur in a particular installation. If this equipment does cause harmful interference to radio or television reception, which can be determined by turning the equipment off and on, the user is encouraged to try to correct the interference by one or more of the following measures:

- Reorient or relocate the receiving antenna
- Increase the separation between the equipment and receiver
- Connect the equipment into an outlet on a circuit different from that to which the receiver is connected
- Consult the dealer or an experienced radio/TV technician for help.

### Radio Frequency Interference Requirements - Canada

This Class B digital apparatus complies with Canadian ICES-003.

Cet appareil numérique de la classe B est conforme à la norme NMB-003 du Canada.

## CE Marking and European Economic Area (EEA)

### Statement of Compliance

Symbol Technologies, Inc., hereby declares that this device is in compliance with all the applicable Directives, 89/336/EEC, 73/23/EEC. A Declaration of Conformity may be obtained from <http://www2.symbol.com/doc/>.

## Warranty

**(A) Warranty** Symbol Technologies (hereafter “Seller”) hardware Products are warranted against defects in workmanship and materials for a period of twelve (12) months from the date of shipment, unless otherwise provided by Seller in writing, provided the Product remains unmodified and is operated under normal and proper conditions. Warranty provisions and durations on software, integrated installed systems, Product modified or designed to meet specific customer specifications (“Custom Products”), remanufactured products, and reconditioned or upgraded products, shall be as provided in the applicable Product specification in effect at the time of purchase or in the accompanying software license.

**(B) Spare Parts** Spare parts (i.e. parts, components, or subassemblies sold by Seller for use in the service and maintenance of Products) are warranted against defects in workmanship and materials for a period of thirty (30) days from the date of shipment. Spare parts may be new or originate from returned units under the conditions set forth in subsection D below.

**(C) Repair of Symbol-branded hardware** For repairs on Symbol-branded hardware Products under this Agreement, including repairs covered by warranty, the repair services provided are warranted against defects in workmanship and materials on the repaired component of the Product for a period of thirty (30) days from the shipment date of the repaired Product, or until the end of the original warranty period, whichever is longer.

**(D) Product Service** Products may be serviced or manufactured with parts, components, or subassemblies that originate from returned products and that have been tested as meeting applicable specifications for equivalent new material and Products. The sole obligation of Seller for defective hardware Products is limited to repair or replacement (at Seller’s option) on a “return to service depot” basis with prior Seller authorization. Customer is responsible for shipment to the Seller and assumes all costs and risks associated with this transportation; return shipment to the Customer will be at Seller’s expense. Customer shall be responsible for return shipment charges for product returned where Seller determines there is no defect (“No Defect Found”), or for product returned that Seller determines is not eligible for warranty repair. No charge will be made to Buyer for replacement parts for warranty repairs. Seller is not responsible for any damage to or loss of any software programs, data or removable data storage media, or the restoration or reinstallation of any software programs or data other than the software, if any, installed by Seller during manufacture of the Product.

**(E) Original Warranty Period** Except for the warranty applying solely to the repaired component arising from a repair service as provided in Section C above, the aforementioned provisions do not extend the original warranty period of any Product that had either been repaired or replaced by Seller.

**(F) Warranty Provisions** The above warranty provisions shall not apply to any Product (i) which has been repaired, tampered with, altered or modified, except by Seller’s authorized service personnel; (ii) in which the defects or damage to the Product result from normal wear and tear, misuse, negligence, improper storage, water or other liquids, battery leakage, use of parts or accessories not approved or supplied by Symbol, or failure to perform operator handling and scheduled maintenance instructions supplied by Seller; (iii) which has been subjected to unusual physical or electrical stress, abuse, or accident, or forces or exposure beyond normal use within the specified operational and environmental parameters set forth in the applicable Product specification; nor shall the above warranty provisions apply to any expendable or consumable items, such as batteries, supplied with the Product.

EXCEPT FOR THE WARRANTY OF TITLE AND THE EXPRESS WARRANTIES STATED ABOVE, SELLER DISCLAIMS ALL WARRANTIES ON PRODUCTS FURNISHED HEREUNDER INCLUDING ALL IMPLIED WARRANTIES OF MERCHANTABILITY AND FITNESS FOR A PARTICULAR USE. ANY IMPLIED WARRANTIES THAT MAY BE IMPOSED BY LAW ARE LIMITED IN DURATION TO THE LIMITED WARRANTY PERIOD. SOME STATES OR COUNTRIES DO NOT ALLOW A LIMITATION ON HOW LONG AN IMPLIED WARRANTY LASTS OR THE EXCLUSION OR LIMITATION OF INCIDENTAL OR CONSEQUENTIAL DAMAGES FOR CONSUMER PRODUCTS. IN SUCH STATES OR COUNTRIES, FOR SUCH PRODUCTS, SOME EXCLUSIONS OR LIMITATIONS OF THIS LIMITED WARRANTY MAY NOT APPLY.

The stated express warranties are in lieu of all obligations or liabilities on the part of Seller for damages, including but not limited to, special, indirect or consequential damages arising out of or in connection with the use or performance of the Product or service. Seller’s liability for damages to Buyer or others resulting from the use of any Product or service furnished hereunder shall in no way exceed the purchase price of said Product or the fair market value of said service, except in instances of injury to persons or property.

## Service Information

Before you use the unit, it must be configured to operate in your facility's network and run your applications.

If you have a problem running your unit or using your equipment, contact your facility's Technical or Systems Support. If there is a problem with the equipment, they will contact the Symbol Support Center:

|   |  |                     |                                   |
|---|--|---------------------|-----------------------------------|
| United States <sup>1</sup>                | 1-800-653-5350<br>1-631-738-2400                       | Canada              | 905-629-7226                      |
| United Kingdom                            | 0800 328 2424  | Asia/Pacific        | 337-6588                          |
| Australia                                 | 1-800-672-906  | Austria/Österreich  | 1-505-5794-0                      |
| Denmark/Danmark                           | 7020-1718  | Finland/Suomi       | 9 5407 580                        |
| France                                    | 01-40-96-52-21   | Germany/Deutschland | 6074-49020                        |
| Italy/Italia                              | 2-484441   | Mexico/México       | 5-520-1835                        |
| Netherlands/Nederland                     | 315-271700   | Norway/Norge        | +47 2232 4375                     |
| South Africa                              | 11-8095311   | Spain/España        | 91 324 40 00<br>Inside Spain      |
| Sweden/Sverige                            | 84452900   |                     | +34 91 324 40 00<br>Outside Spain |
| Latin America<br>Sales Support            | 1-800-347-0178 Inside US<br>+1-954-255-2610 Outside US |                     |                                   |
| Europe/Mid-East<br>Distributor Operations | Contact local distributor or call<br>+44 118 945 7360  |                     |                                   |

<sup>1</sup>Customer support is available 24 hours a day, 7 days a week.

For the latest version of this guide go to: <http://www.symbol.com/manuals>.

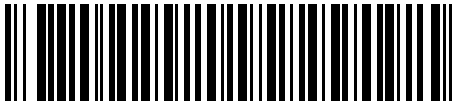

**72-58260-01**  
**Revision B — July 2003**