

PPT 2700 Series



Product Reference Guide



PPT 2700 Series Product Reference Guide

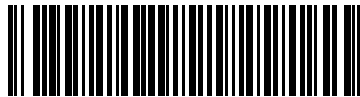

70-37806-02
Revision A — March 2001

***PPT 2700 Series
Product Reference Guide***

70-37806-02

Revision A

March 2001



© 1999-2001 by Symbol Technologies, Inc. All rights reserved.

No part of this publication may be reproduced or used in any form, or by any electrical or mechanical means, without permission in writing from Symbol. This includes electronic or mechanical means, such as photocopying, recording, or information storage and retrieval systems. The material in this manual is subject to change without notice.

The software is provided strictly on an “as is” basis. All software, including firmware, furnished to the user is on a licensed basis. Symbol grants to the user a non-transferable and non-exclusive license to use each software or firmware program delivered hereunder (licensed program). Except as noted below, such license may not be assigned, sublicensed, or otherwise transferred by the user without prior written consent of Symbol. No right to copy a licensed program in whole or in part is granted, except as permitted under copyright law. The user shall not modify, merge, or incorporate any form or portion of a licensed program with other program material, create a derivative work from a licensed program, or use a licensed program in a network without written permission from Symbol. The user agrees to maintain Symbol’s copyright notice on the licensed programs delivered hereunder, and to include the same on any authorized copies it makes, in whole or in part. The user agrees not to decompile, disassemble, decode, or reverse engineer any licensed program delivered to the user or any portion thereof.

Symbol reserves the right to make changes to any software or product to improve reliability, function, or design.

Symbol does not assume any product liability arising out of, or in connection with, the application or use of any product, circuit, or application described herein.

No license is granted, either expressly or by implication, estoppel, or otherwise under any Symbol Technologies, Inc., intellectual property rights. An implied license only exists for equipment, circuits, and subsystems contained in Symbol products.

Symbol, Spectrum One, and Spectrum24 are registered trademarks of Symbol Technologies, Inc. Other product names mentioned in this manual may be trademarks or registered trademarks of their respective companies and are hereby acknowledged.

Symbol Technologies, Inc.
One Symbol Plaza
Holtsville, New York 11742-1300
<http://www.symbol.com>

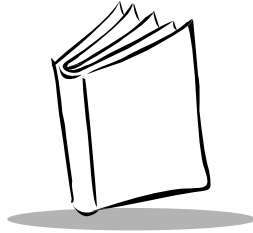

Contents

About This Guide

Introduction	ix
Chapter Descriptions	ix
Notational Conventions	x
Related Documents	xi
Service Information	xi
Symbol Support Centers	xii
Warranty	xiv
Warranty Coverage and Procedure	xv
General	xv

Chapter 1. Getting Started

Introduction	1-1
Unpacking the Terminal	1-1
Parts of the PPT 2700	1-2
Installing Batteries	1-4
Charging the Battery	1-5
Using the Cradle to Charge the Battery	1-5
Charging Spare Batteries	1-7
Using the Synchronization Cable to Charge the Battery	1-7
Attaching the Handstrap	1-9
Attaching the Wrist Strap	1-9
Starting the PPT 2700	1-11
Aligning the Screen	1-11
Setting Up Your Terminal	1-13

Chapter 2. Operating the PPT 2700

Introduction	2-1
Using the Power Button	2-1

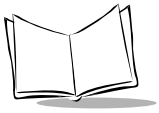

Controlling the Contrast/Backlight	2-1
Using the Stylus	2-2
Today Screen	2-3
Selecting Programs	2-4
Using the Navigation Bar and Command Bar	2-5
Using Pop-up Menus	2-5
Entering Information	2-6
Typing Using the Input Panel	2-6
Writing on the Screen	2-7
Drawing on the Screen	2-8
Recording a Message	2-9
Finding Information	2-10
Scanning	2-11
Scanning PDF417 Bar Codes	2-11
Resetting Your PPT 2700 Terminal	2-12
Performing a Warm Boot	2-12
Performing a Cold Boot	2-13

Chapter 3. Customizing Your PPT 2700

Introduction	3-1
Adjusting Settings	3-1
Adding and Removing Programs	3-2
FFS Partitions	3-2
Working with FFS Partitions	3-2
Non-FFS Partitions	3-3
Downloading Partitions to the Terminal	3-4
Adding Programs	3-4
Adding a Program to the Start Menu	3-5
Removing Programs	3-6

Chapter 4. Communications

Introduction	4-1
Installing ActiveSync Software	4-1
Performing an ActiveSync for the First Time	4-2
Performing ActiveSync using the Synchronization Cable	4-2
Performing ActiveSync using the Cradle	4-3
Performing Subsequent ActiveSync Operations	4-5
Performing a Remote ActiveSync	4-6

Chapter 5. Applications

Introduction	5-1
------------------------	-----

Calendar	5-2
Creating Appointments	5-2
Using the Summary Screen	5-4
Creating Meeting Requests	5-4
Contacts	5-5
Using the Summary Screen	5-7
Tasks	5-8
Using the Summary Screen	5-10
Notes	5-11
Inbox	5-13
Synchronizing E-mail Messages	5-13
Connecting Directly to an E-mail Server	5-13
Using the Message List	5-15
Creating E-mail Messages	5-17
Managing E-mail Messages and Folders	5-18

Chapter 6. Pocket Internet Explorer

Introduction	6-1
Mobile Favorites	6-1
Favorite Links	6-1
Creating Mobile Favorites	6-2
Saving Memory on your Terminal	6-2
Channels	6-3
Using Mobile Channels	6-3
Using Pocket Internet Explorer	6-4
Browsing the Web	6-6

Chapter 7. Connections

Introduction	7-1
Transferring Items Using Infrared	7-2
Connecting to an ISP	7-2
Connecting to Your Network	7-4
Creating a Modem Connection to a Network	7-4
Disconnecting	7-6
Connecting Directly to an E-mail Server	7-6
Setting Up an E-mail Service	7-7
Getting Help Connecting	7-8

Chapter 8. Spectrum24 Network Configuration

Introduction	8-1
NICTT	8-1

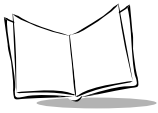

Spectrum24 Settings Control Panel Applet	8-3
Configuring the PPT 2740/2742 (1 and 2 MB radio)	8-4
Using NICTT on the PPT 2740/2742	8-4
Using Spectrum24 Settings Control Panel Applet for the PPT 2740/2742	8-9
Configuring the PPT 2746 (11 MB radio)	8-13
Using NICTT on the PPT 2746	8-13
Using Spectrum24 Settings Control Panel Applet for PPT 2746	8-20

Chapter 9. Wireless Wide Area Network Configuration

Introduction	9-1
Configuring a CDPD WAN Connection (PPT 2733)	9-1
Configuration Wizard	9-2
Maintenance Screens and Menus	9-7
Modem Menu	9-13
Advanced Menu	9-14
Help	9-16
Configuring a GSM WAN Connection (PPT 2734)	9-17
Connecting via GSM	9-20

Chapter 10. Software Installation on Development PC

Introduction	10-1
Before You Install the SDK	10-1
Symbol Windows CE SDK	10-2
Installing the SDK on the Development PC	10-2
Installing the SDK	10-2
Installing Other Development Software	10-2

Chapter 11. Configuring the Terminal

Introduction	11-1
Starting Terminal Configuration Manager	11-2
Defining Script Properties	11-4
Creating the Script for the Hex Image	11-6
Open a New or Existing Script	11-6
Copy Components to the Script	11-7
Save the Script	11-7
Building the Image	11-8
Sending the Hex Image	11-10
Saving the Script	11-10
Connect The Terminal and Development PC	11-10
Begin the Send in TCM	11-10
Setting Up IPL to Receive the File	11-11

Error Messages	11-16
IPL Error Detection	11-16
TCM Error Messages	11-17
Creating a Splash Screen	11-19
Loading the Splash Screen via TCM	11-20

Chapter 12. Maintenance and Troubleshooting

Introduction	12-1
Maintaining the PPT 2700	12-1
Troubleshooting	12-2

Appendix A. Character Recognizer

Appendix B. Demo Program

Introduction	B-1
Setup	B-3
Control Panel	B-3
NICTT	B-4
Diagnostics	B-5
Main Menu	B-5
Scanner	B-6
Scanning Data Fields	B-6
Scanning Options	B-7
File Explorer	B-7
MSR Sample	B-8
CE Apps	B-9
About	B-9

Appendix C. GSM Demo Program

Introduction	C-1
Using GsmDemo	C-1
Working with Text Messages	C-3
GsmDemo Menu Commands	C-7
Options Menu	C-7
Help Menu	C-8

Appendix D. Technical Specifications

Environment	D-1
-------------------	-----

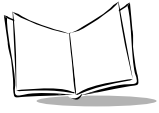

Index

Feedback

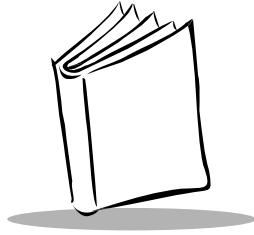

About This Guide

Introduction

The *PPT 2700 Series Product Reference Guide* provides information about the PPT 2700 Series terminal and its accessories. The PPT 2700 Series includes the following variations of the terminal:

- PPT 2700: batch
- PPT 274x: Spectrum24 LAN radio
- PPT 273x: Wide Area Network (WAN) terminals (GSM and CDPD).

Chapter Descriptions

Topics covered in this guide are as follows:

- *Chapter 1, Getting Started* explains the physical buttons and controls on your PPT 2700 terminal, how to install and charge the batteries, start your PPT 2700 terminal for the first time, and attach the handstrap and wriststrap.
- *Chapter 2, Operating the PPT 2700* explains how to use your terminal, including instructions for powering on and resetting the terminal, entering information, scanning, and using the stylus.
- *Chapter 3, Customizing Your PPT 2700* explains how to adjust settings on the terminal, and add and delete programs.
- *Chapter 4, Communications* explains how to use Microsoft® ActiveSync™ for communications between the terminal and host PC.
- *Chapter 5, Applications* describes how to use the Calendar, Contacts, Tasks, Notes and Inbox applications.

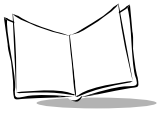

- *Chapter 6, Pocket Internet Explorer* explains how to set up favorite links and channels, and browse the web on your terminal.
- *Chapter 7, Connections* describes how to connect the terminal to your network and e-mail server, and transfer information via infrared.
- *Chapter 8, Spectrum24 Network Configuration* describes NICTT and Spectrum24 Settings Control Panel Applet, the utilities that monitor and configure the Spectrum24 wireless connection.
- *Chapter 9, Wireless Wide Area Network Configuration* describes how to configure your terminal for CDPD and GSM WWAN connection.
- *Chapter 10, Software Installation on Development PC* provides instructions for installing the Software Developer's Kit on your host PC.
- *Chapter 11, Configuring the Terminal* describes how to install and use the Terminal Configuration Manager (TCM) and Initial Program Loader (IPL).
- *Chapter 12, Maintenance and Troubleshooting* provides information to help you take proper care of your PPT 2700 terminal and solve problems that may come up.
- *Appendix A, Character Recognizer* details how to write letters on your terminal so they are correctly translated into text.
- *Appendix B, Demo Program* provides an overview of the PPT 2700 demo program applications, such as scanning, setup, diagnostic utilities, and file management.
- *Appendix C, GSM Demo Program* explains how to explore what features GSM and the PPT 2734 terminal offer you, including sending and receiving SMS messages.
- *Appendix D, Technical Specifications* includes a table listing the technical specifications for the terminal.

Notational Conventions

This document uses these conventions:

- “terminal” or “PPT 2700” refers to any model of PPT 2700.
- “User” refers to anyone using an application on the PPT 2700.
- “You” refers to the End User, System Administrator or Technical Support person using this manual as a reference to install, configure, operate, maintain and troubleshoot the PPT 2700.
- Italics are used to highlight specific items in the general text, and to identify chapters and sections in this and related documents. It also identifies names of dialog boxes and tabs within dialog boxes.
- Bullets (•) indicate:

- lists of alternatives or action items.
- lists of required steps that are not necessarily sequential.
- Numbered lists indicate a set of sequential steps, i.e., those that describe step-by-step procedures.

Related Documents

The following documents provide more information on your PPT 2700 terminal.

- *PPT 2700 Quick Reference Guide*, p/n 70-38705-xx
- *CRD 2700-1000S Cradle Quick Reference Guide*, p/n 70-38707-xx
- *CRD 2700-4000E 4-Slot Ethernet Cradle Quick Reference Guide*, p/n 72-50357-xx
- *CHX700-4000C 4-Slot Charging Cradle Quick Reference Guide*, p/n 72-50367-xx
- *SPT 1734/PPT 2734 Terminals GSM WWAN Developer's Guide*, p/n 72-44271-xx
- *Symbol Software Developer's Kit (SDK) for the PPT 2700 Pocket PC*, available at www.symbol.com/services/downloads.

Service Information

If you have a problem with the PPT 2700 equipment, contact the Symbol Support Center. If your problem cannot be resolved over the phone, you may need to return your equipment for servicing. If that is necessary, you will be given special directions.

Note: *Symbol Technologies is not responsible for any damages incurred during shipment if the approved shipping container is not used. Shipping the units improperly can possibly void the warranty. If the original shipping container has not been kept, contact Symbol to have another sent to you.*

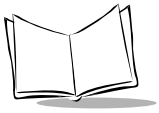

Symbol Support Centers

For service information, warranty information or technical assistance contact or call the Symbol Support Center in:

United States

Symbol Technologies, Inc.
One Symbol Plaza
Holtsville, New York 11742-1300
1-800-659-2240

United Kingdom

Symbol Technologies
Symbol Place
Winnersh Triangle, Berkshire RG41 5TP
United Kingdom
0800 328 2424 (Inside UK)
+44 118 945 7529 (Outside UK)

Australia

Symbol Technologies Pty. Ltd.
432 St. Kilda Road
Melbourne, Victoria 3004
1-800-672-906 (Inside Australia)
+61-3-9866-6044 (Outside Australia)

Denmark

Symbol Technologies AS
Gydevang 2,
DK-3450 Allerod, Denmark
7020-1718 (Inside Denmark)
+45-7020-1718 (Outside Denmark)

Canada

Symbol Technologies Canada, Inc.
2540 Matheson Boulevard East
Mississauga, Ontario, Canada L4W 4Z2
905-629-7226

Asia/Pacific

Symbol Technologies Asia, Inc.
230 Victoria Street #04-05
Bugis Junction Office Tower
Singapore 188024
337-6588 (Inside Singapore)
+65-337-6588 (Outside Singapore)

Austria

Symbol Technologies Austria GmbH
Prinz-Eugen Strasse 70
Suite 3
2.Haus, 5.Stock
1040 Vienna, Austria
1-505-5794 (Inside Austria)
+43-1-505-5794 (Outside Austria)

Europe/Mid-East Distributor Operations

Contact your local distributor or call
+44 118 945 7360

Finland

Oy Symbol Technologies
Kaupintie 8 A 6
FIN-00440 Helsinki, Finland
9 5407 580 (Inside Finland)
+358 9 5407 580 (Outside Finland)

Germany

Symbol Technologies GmbH
Waldstrasse 68
D-63128 Dietzenbach, Germany
6074-49020 (Inside Germany)
+49-6074-49020 (Outside Germany)

Latin America Sales Support

7900 Glades Road
Suite 340
Boca Raton, Florida 33434 USA
1-800-347-0178 (Inside United States)
+1-561-483-1275 (Outside United States)

Netherlands

Symbol Technologies
Kerkplein 2, 7051 CX
Postbus 24 7050 AA
Varsseveld, Netherlands
315-271700 (Inside Netherlands)
+31-315-271700 (Outside Netherlands)

France

Symbol Technologies France
Centre d'Affaire d'Antony
3 Rue de la Renaissance
92184 Antony Cedex, France
01-40-96-52-21 (Inside France)
+33-1-40-96-52-50 (Outside France)

Italy

Symbol Technologies Italia S.R.L.
Via Cristoforo Columbo, 49
20090 Trezzano S/N Naviglio
Milano, Italy
2-484441 (Inside Italy)
+39-02-484441 (Outside Italy)

Mexico

Symbol Technologies Mexico Ltd.
Torre Picasso
Boulevard Manuel Avila Camacho No 88
Lomas de Chapultepec CP 11000
Mexico City, DF, Mexico
5-520-1835 (Inside Mexico)
+52-5-520-1835 (Outside Mexico)

Norway

Symbol Technologies
Trollasveien 36
Postboks 72
1414 Trollasen, Norway
66810600 (Inside Norway)
+47-66810600 (Outside Norway)

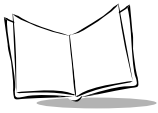

South Africa

Symbol Technologies Africa Inc.
Block B2
Rutherford Estate
1 Scott Street
Waverly 2090 Johannesburg
Republic of South Africa
11-4405668 (Inside South Africa)
+27-11-4405668 (Outside South Africa)

Spain

Symbol Technologies S.A.
Edificio la Piovera Azul
C. Peonias, No. 2 - Sexta Planta
28042 Madrid, Spain
9-1-320-39-09 (Inside Spain)
+34-9-1-320-39-09 (Outside Spain)

Sweden

Symbol Technologies AB
Albygatan 109D
Solna
Sweden
84452900 (Inside Sweden)
+46 84452900 (Outside Sweden)

If you purchased your Symbol product from a Symbol Business Partner, contact that Business Partner for service.

Warranty

Symbol Technologies, Inc ("Symbol") manufactures its hardware products in accordance with industry-standard practices. Symbol warrants that for a period of twelve (12) months from date of shipment, products will be free from defects in materials and workmanship.

This warranty is provided to the original owner only and is not transferable to any third party. It shall not apply to any product (i) which has been repaired or altered unless done or approved by Symbol, (ii) which has not been maintained in accordance with any operating or handling instructions supplied by Symbol, (iii) which has been subjected to unusual physical or electrical stress, misuse, abuse, power shortage, negligence or accident or (iv) which has been used other than in accordance with the product operating and handling instructions. Preventive maintenance is the responsibility of customer and is not covered under this warranty.

Wear items and accessories having a Symbol serial number, will carry a 90-day limited warranty. Non-serialized items will carry a 30-day limited warranty.

Warranty Coverage and Procedure

During the warranty period, Symbol will repair or replace defective products returned to Symbol's manufacturing plant in the US. For warranty service in North America, call the Symbol Support Center at 1-800-653-5350. International customers should contact the local Symbol office or support center. If warranty service is required, Symbol will issue a Return Material Authorization Number. Products must be shipped in the original or comparable packaging, shipping and insurance charges prepaid. Symbol will ship the repaired or replacement product freight and insurance prepaid in North America. Shipments from the US or other locations will be made F.O.B. Symbol's manufacturing plant.

Symbol will use new or refurbished parts at its discretion and will own all parts removed from repaired products. Customer will pay for the replacement product in case it does not return the replaced product to Symbol within 3 days of receipt of the replacement product. The process for return and customer's charges will be in accordance with Symbol's Exchange Policy in effect at the time of the exchange.

Customer accepts full responsibility for its software and data including the appropriate backup thereof.

Repair or replacement of a product during warranty will not extend the original warranty term.

Symbol's Customer Service organization offers an array of service plans, such as on-site, depot, or phone support, that can be implemented to meet customer's special operational requirements and are available at a substantial discount during warranty period.

General

Except for the warranties stated above, Symbol disclaims all warranties, express or implied, on products furnished hereunder, including without limitation implied warranties of merchantability and fitness for a particular purpose. The stated express warranties are in lieu of all obligations or liabilities on part of Symbol for damages, including without limitation, special, indirect, or consequential damages arising out of or in connection with the use or performance of the product.

Seller's liability for damages to buyer or others resulting from the use of any product, shall in no way exceed the purchase price of said product, except in instances of injury to persons or property.

Some states (or jurisdictions) do not allow the exclusion or limitation of incidental or consequential damages, so the proceeding exclusion or limitation may not apply to you.

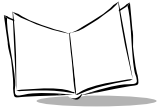

PPT 2700 Series Product Reference Guide

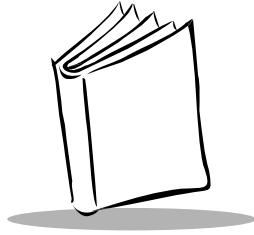

Chapter 1

Getting Started

Introduction

This chapter explains the physical buttons and controls on your PPT 2700 terminal, how to install and charge the batteries, attach the handstrap, and start your PPT 2700 terminal for the first time.

Unpacking the Terminal

Carefully remove all protective material from around the terminal and save the shipping container for later storage and shipping.

Verify that you received all equipment listed on the packing slip and inspect the equipment for damage. If you are missing any equipment or if you find any damaged equipment, contact the Symbol Technologies Support Center immediately. See [page xii](#) for contact information.

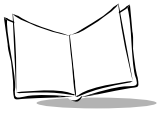

Parts of the PPT 2700

Front View

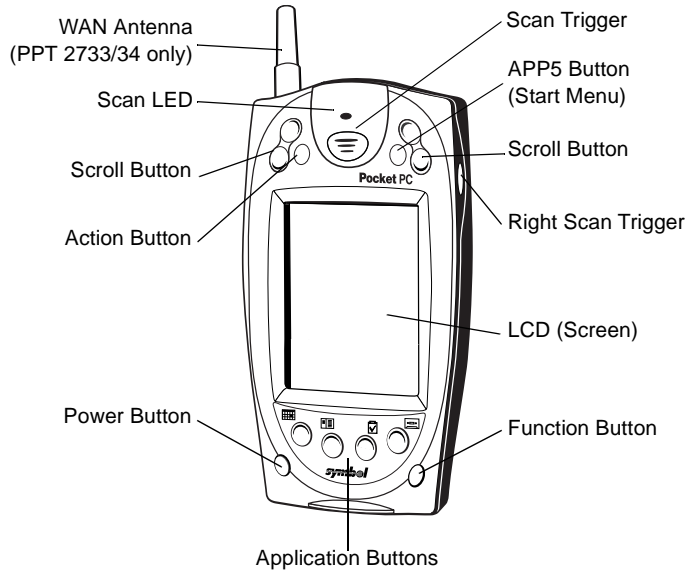

Left View

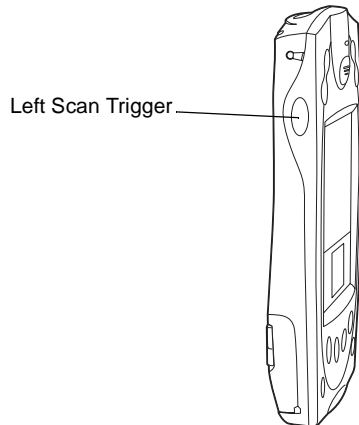

Figure 1-1. Parts of the PPT 2700

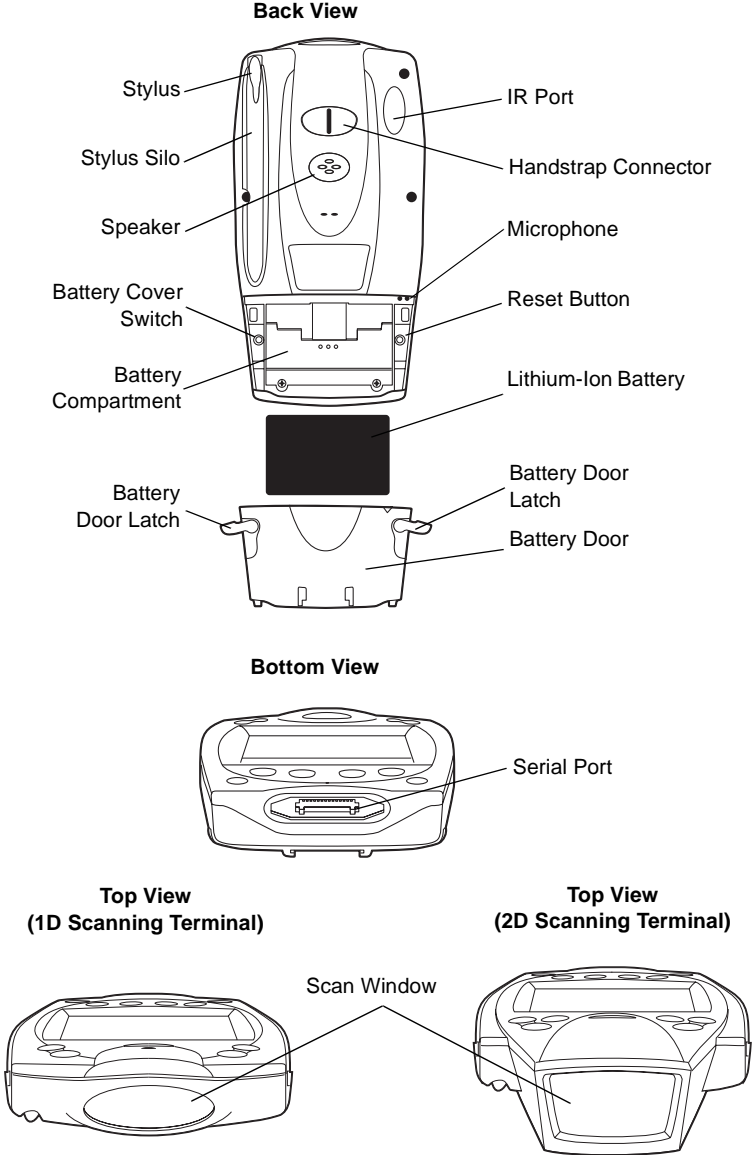
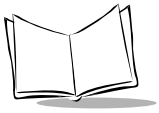

Figure 1-2. Parts of the PPT 2700 (continued)



Installing Batteries

Before using your PPT 2700, install the lithium-ion battery. The battery fits behind the battery door on the back of the PPT 2700.

To install the battery in your PPT 2700:

1. Open the latches on the battery cover and lift the battery cover away from the PPT 2700.

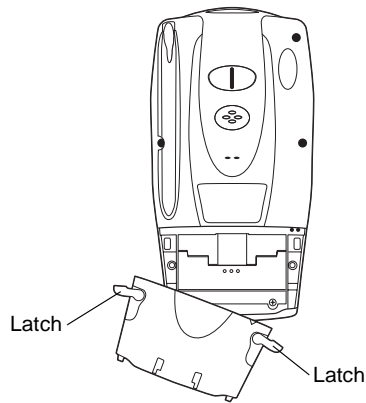

Figure 1-3. Removing the Battery Cover

2. Insert the lithium-ion battery in the battery compartment with the battery tether positioned properly (as shown below), making sure the battery snaps into place.

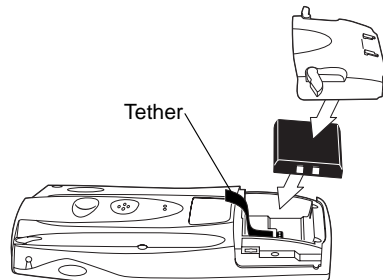

Figure 1-4. Inserting the Battery

3. Replace the battery cover and press down firmly on the cover while re-securing the latches.

Note: *Be careful to position the battery latches completely open while securing the battery cover on the terminal.*

Charge the battery in the terminal for approximately 2 1/2 hours before initial use.

Charging the Battery

Before using your terminal for the first time, charge the battery. Also, when battery voltage is low, a warning message appears indicating the battery needs to be charged. You can charge the battery using either the CRD 2700 cradle or the Synchronization Cable.

Your terminal is equipped with a memory backup battery which automatically charges from the fully-charged lithium-ion battery. This backup battery retains data in memory when the terminal's battery is removed, and takes several hours to charge when you first use your terminal.

Note: *If you remove your lithium-ion battery before the backup battery is fully charged, data may be lost. For this reason, DO NOT remove the battery within the first ten hours of use.*

Using the Cradle to Charge the Battery

To charge the terminal's battery using the CRD 2700 cradle:

1. Connect the power supply to the power port on the back of the cradle, and the other end of the power supply to a wall outlet.

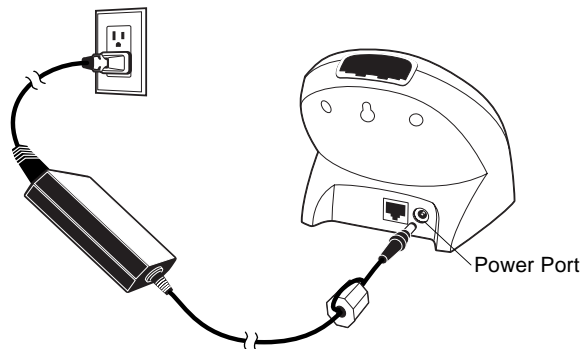
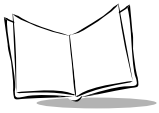

Figure 1-5. Connecting the Power Supply



2. Connect the cradle to your computer by plugging the serial cable into the serial port on the back of the cradle, and the other end of the cable into the serial port on your computer.

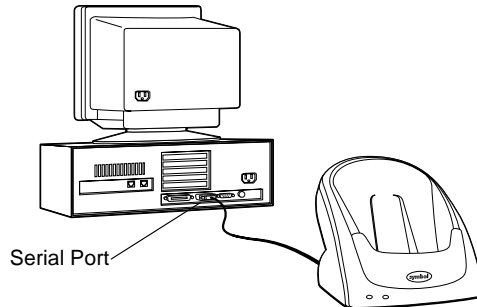

Figure 1-6. Connecting the Cradle to the Host Computer

3. Insert the PPT 2700 terminal in the cradle.

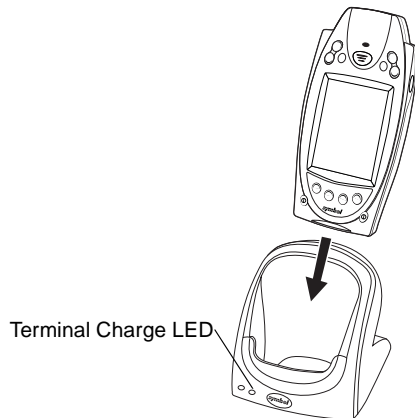

Figure 1-7. Inserting the Terminal in the Cradle

4. The Terminal Charge LED turns red to indicate charging, then green when the battery is fully charged.

Note: *If the cradle is not connected to the host computer via serial cable, the Terminal Charge LED shuts off when the battery is fully charged.*

The terminal's battery is fully charged after approximately 2 1/2 hours.

Note: *If the battery in the terminal is low, the Terminal Charge LED may flicker or turn yellow during an ActiveSync operation. The LED returns to red when the operation is complete.*

Charging Spare Batteries

To charge a spare battery, insert the battery in the spare battery charging slot in the back of the cradle, oriented so the contacts are facing down and towards the back of the cradle. Press the battery down into the slot until firmly seated.

The Spare Battery Charge LED turns red to indicate charging, then green when the battery is fully charged. The battery is fully charged after approximately 2 1/2 hours.

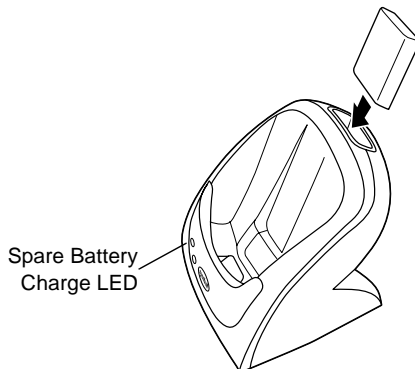
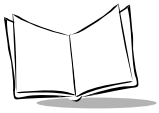

Figure 1-8. Charging the Spare Battery

Using the Synchronization Cable to Charge the Battery

To charge the terminal's battery using the optional Synchronization Cable:



1. Insert the cable into the bottom of the terminal.

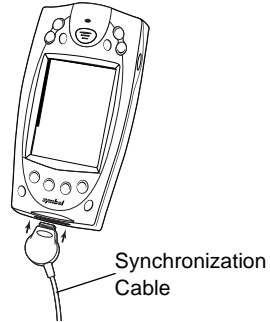

Figure 1-9. Inserting the Cable in the Terminal

2. Plug the power cable into a wall outlet and plug the other end into the battery charging receptacle on the side of the Synchronization Cable.

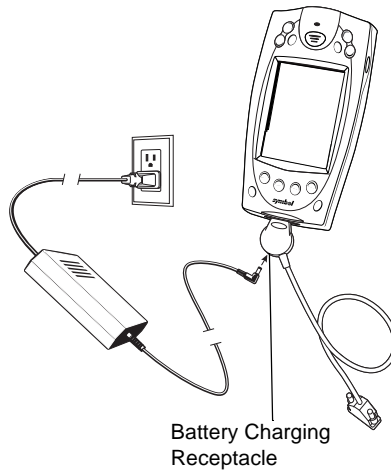

Figure 1-10. Connecting the Power Cable

Attaching the Handstrap

The PPT 2700 has an optional handstrap which increases comfort when holding the terminal for extended periods of time. To attach the handstrap to the back of the terminal:

1. Thread the round metal piece through the metal handstrap connector on the back of the terminal.
2. Slide the flat metal piece into the handstrap connection on the bottom of the terminal.

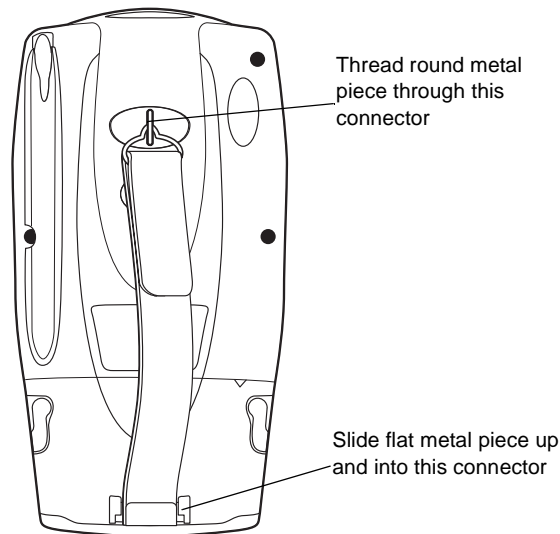

Figure 1-11. Attaching the Handstrap

3. Adjust the velcro strap to fit your hand.

Attaching the Wrist Strap

An optional wrist strap is available from Symbol which helps prevent damage to the terminal if you drop it. To attach the wrist strap:

1. Thread the elastic band on the wrist strap through the metal handstrap connector on the back of the terminal.

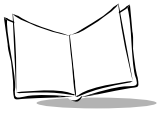

2. Slip the strap through the elastic band on the other side of the connector, and pull it through to secure the strap to the connector.

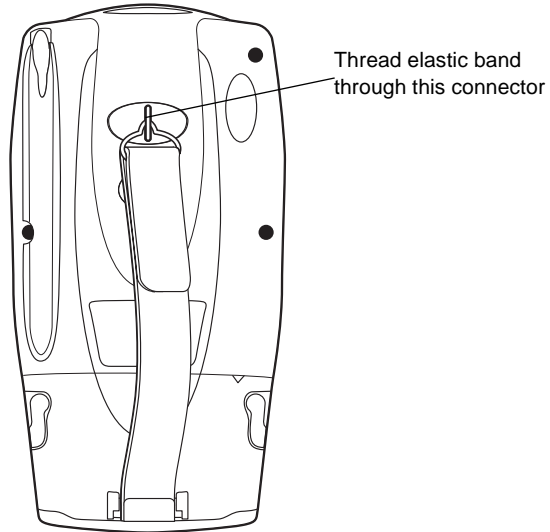

Figure 1-12. Attaching the Wriststrap

3. Slide your hand through the strap.

Starting the PPT 2700

After installing and charging the battery, start the terminal by pressing the red power button. If the terminal does not power on, reset it. See [Performing a Cold Boot](#) on page 2-13.

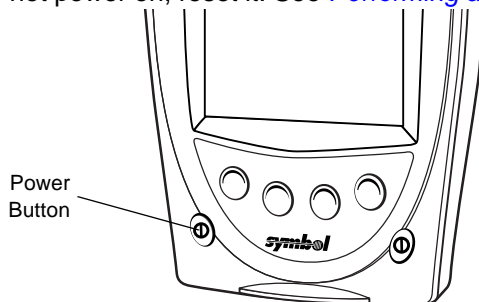

Figure 1-13. Power Button

As the terminal initializes its unique Flash File system, the Symbol splash screen displays for about a minute. When the Welcome screen appears, tap anywhere on the screen to continue to the Align screen.

Aligning the Screen

To align your PPT 2700 so the cursor on the touch screen aligns with the tip of your stylus:

1. If necessary, adjust the contrast on the PPT 2700 so the screen is clear and readable. See [Controlling the Contrast/Backlight](#) on page 2-1 for instructions.
2. Remove the stylus from its storage silo on the back of the PPT 2700.
3. Tap the center of each target that appears on the screen with the tip of the stylus.

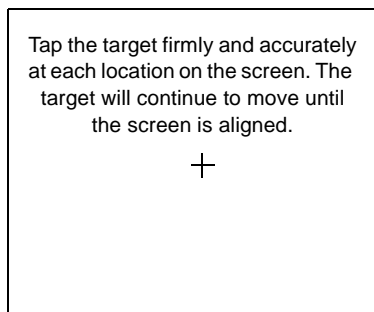
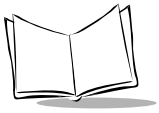

Figure 1-14. Tapping the Target



4. Follow the directions on the screen which lead you through a simple exercise illustrating how to use the stylus and pop-up menus.

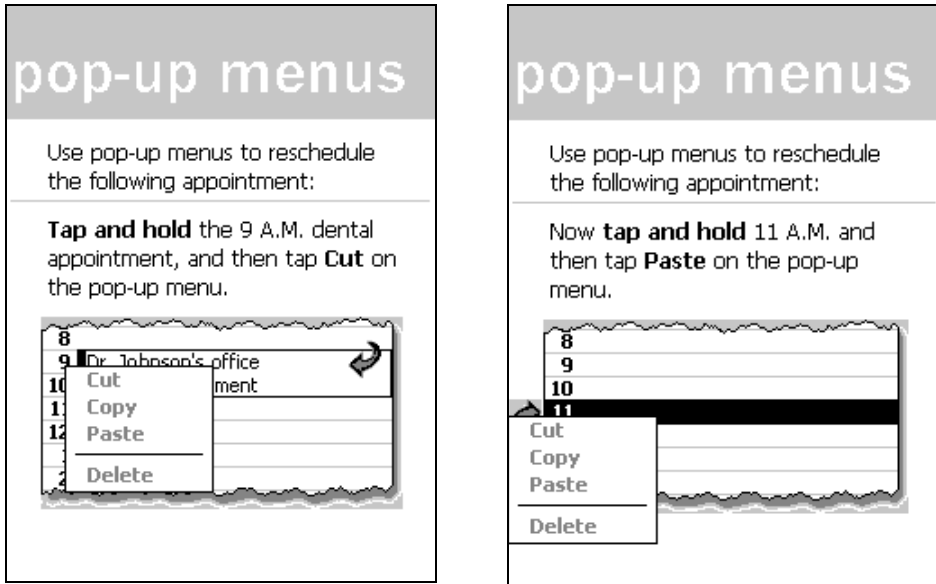
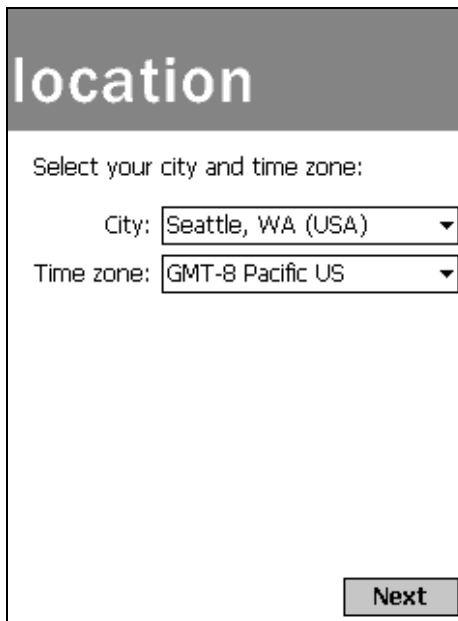

Figure 1-15. Using Pop-up Menus

5. Use the drop-down menus to set your city and time zone, and tap **Next**.



location

Select your city and time zone:

City: Seattle, WA (USA) ▼

Time zone: GMT-8 Pacific US ▼

Next

Figure 1-16. Setting City and Time Zone on the PPT 2700

Note: *These initial setup screens appear each time you perform a hard reset.*

Setting Up Your Terminal

Refer to the following chapters for setting up your terminal:

- For customizing the settings on your PPT 2700, see [Chapter 3, Customizing Your PPT 2700](#).
- To configure your PPT 274X for Spectrum24, see [Chapter 8, Spectrum24 Network Configuration](#).
- To configure your PPT 273X for a WWAN network, see [Chapter 9, Wireless Wide Area Network Configuration](#).

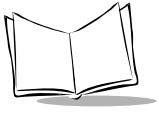

- To install development software on your development PC, see [Chapter 10, *Software Installation on Development PC*](#).
- To configure your terminal using the Terminal Configuration Manager, see [Chapter 11, *Configuring the Terminal*](#).

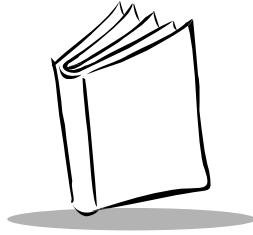

Chapter 2

Operating the PPT 2700

Introduction

This chapter provides basic instructions for using and navigating your PPT 2700 terminal.

Using the Power Button

Press the power button on the lower left-hand side of the terminal to turn the PPT 2700 on and off.

Controlling the Contrast/Backlight

The Function button allows you to adjust the contrast of the screen and control the backlight.

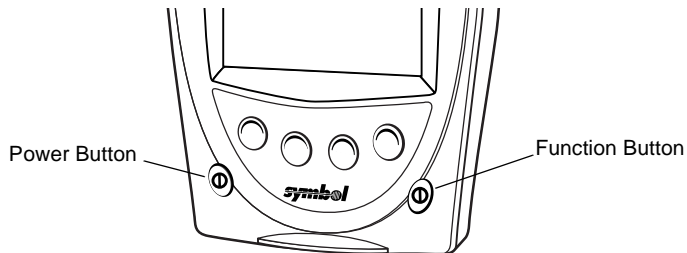
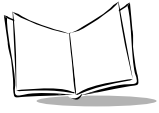

Figure 2-1. Power and Function Buttons



To adjust the contrast:

1. Press and hold the Function button.
2. Press the “up” scroll button at the top of the terminal to darken the screen, or the “down” scroll button to lighten the screen.

To turn the backlight on or off:

1. Press and hold the Function button.
2. Press any Application button.

Using the Stylus

Your PPT 2700 has a stylus for selecting items and entering information. The stylus functions as a mouse.

- **Tap:** Touch the screen once with the stylus to open items and select options.
- **Drag:** Hold the stylus on the screen and drag across the screen to select text and images. Drag in a list to select multiple items.
- **Tap-and-hold:** Tap and hold the stylus on an item to see a list of actions available for that item. On the pop-up menu that appears, tap the action you want to perform.

Today Screen

When you turn on your terminal for the first time each day (or after 4 hours of inactivity), the Today screen appears. You can also display it by tapping , then Today. On the Today screen, you can see important information for the day.

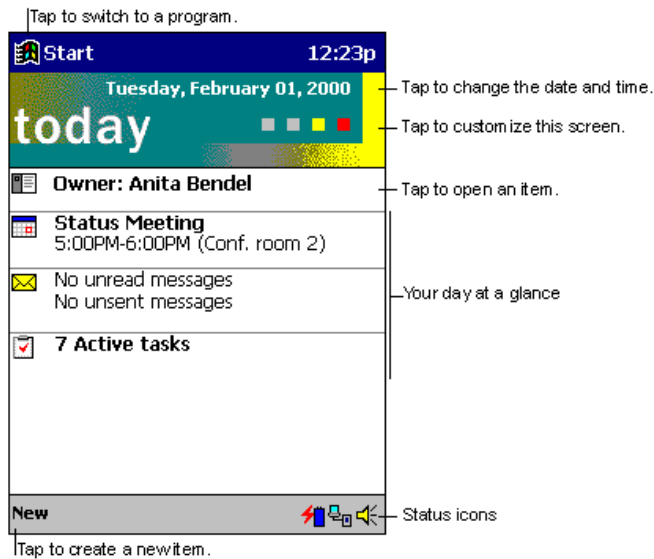







Figure 2-2. Today Screen

You may see the following status icons on the command bar located at the bottom of the screen:

Table 2-1. Status Icons

Icon	Meaning
	Turns all sounds on and off.
	Backup battery is low.
	Backup battery is very low.
	Main batteries are charging.
	Main batteries are low.

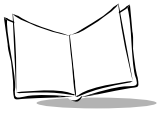







Table 2-1. Status Icons (Continued)

Icon	Meaning
	Main batteries are very low.
	External (AC) power source is connected.
	Dial-up connection is active.
	Direct connection is active.





Selecting Programs

To select a program, tap  , Programs, then the program name. (To select which programs appear on this menu, see [Adjusting Settings](#) on page 3-1.)

Note: *Some programs have abbreviated labels for check boxes and drop-down menus. To see the full label, hold the stylus on the label. Drag the stylus off the label so that the command is not carried out.*

[Table 2-2](#) lists the default programs you can access by pressing an application button on the front of the terminal. The icons on the buttons identify the programs they access.

Table 2-2. Program icons

Icon	Button	Program	Description
	App 1	Calendar	Keep track of your appointments and create meeting requests.
	App 2	Contacts	Keep track of your friends and colleagues.
	App 3	Tasks	Keep track of your tasks.
	App 4	Notes	Create handwritten or typed notes, drawings, and recordings.

You can assign a different application to each application button. See [Chapter 3, Customizing Your PPT 2700](#).

Using the Navigation Bar and Command Bar

The navigation bar at the top of the screen displays the active program and current time, and allows you to select programs and close screens.

Use the command bar at the bottom of the screen to perform tasks in programs. The command bar includes menu names, buttons, and the input panel button. To create a new item in the current program, tap **New**. To see the name of a button, tap and hold the stylus on the button. Drag the stylus off the button so that the command is not carried out.

Using Pop-up Menus

With pop-up menus, you can quickly choose an action for an item. For example, use the pop-up menu in the contact list to delete a contact, make a copy of a contact, or send an e-mail message to a contact. The actions in the pop-up menus vary from program to program.

To access a pop-up menu, hold the stylus on the item you want to perform the action on. When the menu appears, lift the stylus, and tap the action to perform, or tap outside the menu to close it without performing an action.

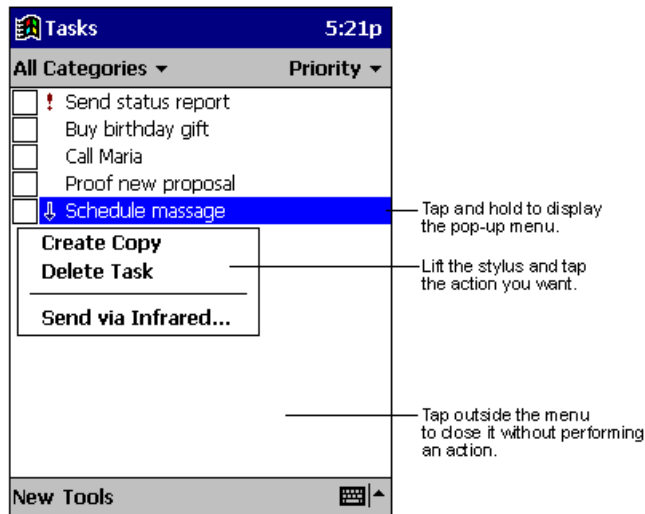
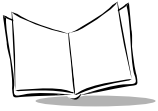

Figure 2-3. Pop-up Menu



Entering Information

To enter information, you may:

- Use the input panel to enter typed text, either using the soft keyboard or Character Recognizer.
- Write directly on the screen.
- Draw pictures on the screen.
- Use ActiveSync to synchronize or copy information from your desktop computer to your terminal. For more information on ActiveSync, see [Chapter 4, Communications](#) or ActiveSync Help on your desktop computer.

Typing Using the Input Panel

Use the input panel to enter information in any program. You can either type using the soft keyboard or write using Character Recognizer. In either case, the characters appear as typed text on the screen.

To show or hide the input panel, tap the **Input Panel** button. Tap the arrow next to this button to see your choices.

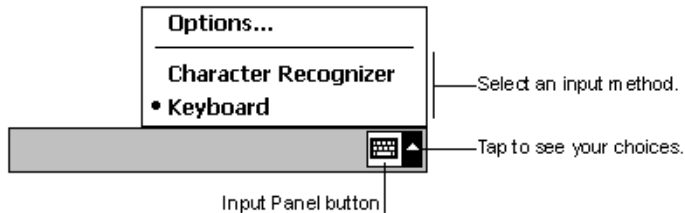



Figure 2-4. Input Panel Button

When you use the input panel, your terminal anticipates the word you are typing or writing and displays it above the input panel. When you tap the displayed word, it is inserted into your text at the insertion point. The more you use your terminal, the more words it learns to anticipate.

To change word suggestion options, such as the number of words suggested at one time, tap , **Settings, Personal** tab, **Input**, then the **Word Completion** tab.

To type with the soft keyboard:

1. Tap the arrow next to the **Input Panel** button, then **Keyboard**.

2. On the soft keyboard that is displayed, tap the keys with your stylus.

To use Character Recognizer:

1. Tap the arrow next to the **Input Panel** button, then **Character Recognizer**.
2. Write a letter in the box.

When you write a letter, it is converted to typed text that appears on the screen. For instructions on using Character Recognizer, see [Appendix A, Character Recognizer](#).

Selecting Text

To edit or format typed text, select it by dragging the stylus across the text. Cut, copy, and/or paste text by holding the selected words then tapping an editing command on the pop-up menu, or by tapping the command on the Edit menu.

Writing on the Screen

In any program that accepts writing, such as the Notes program and the Notes tab in Calendar, Contacts, and Tasks, you can use your stylus to write directly on the screen.

To write on the screen, tap the Pen button to switch to writing mode. Lines appear on the screen to help you write.

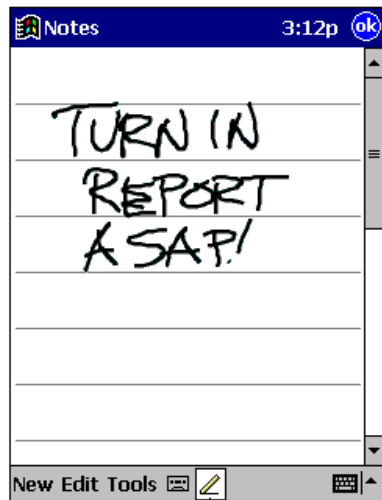

Tap the Pen button and use your stylus like a pen.

Figure 2-5. Writing on the Screen

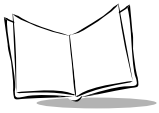

Note: Some programs that accept writing do not have the Pen button. See the documentation for that program to find out how to switch to writing mode.

Selecting Writing

To select writing to edit or format:

1. Tap and hold the stylus next to the text you want to select until the insertion point appears.
2. Drag the stylus across the text.

If you accidentally write on the screen, tap **Tools**, then **Undo** and try again. You can also select text by tapping the Pen button to deselect it, then dragging the stylus across the screen.

You can cut, copy, and paste written text in the same way you work with typed text: tap and hold the selected words, then tap the command from the pop-up menu, or select the command from the Edit menu.

Drawing on the Screen

Drawing on the screen is similar to writing on the screen. To create a drawing, cross three ruled lines on your first stroke. A drawing box appears. Subsequent strokes in or touching the drawing box become part of the drawing. Drawings that do not cross three ruled lines are treated as writing.

Note: To change the zoom level, tap **Tools**, then a zoom level.

Selecting a Drawing

To select a drawing to edit or format, tap and hold the stylus on the drawing until the selection handle appears.

To select multiple drawings, deselect the Pen button, then drag to select the drawings you want.

To cut, copy, and paste drawings, tap and hold the selected drawing, then tap an editing command on the pop-up menu, or tap the command on the Edit menu. To resize a drawing, deselect the Pen button and drag a selection handle.

Recording a Message

You may record a message to capture thoughts, reminders, and phone numbers. In Calendar, Tasks, and Contacts, you can include a recording in the **Notes** tab. In the Notes program, you can either create a stand-alone recording or include a recording in a written note. If you want to include the recording in a note, open the note first.

To create a recording:

1. Tap the tape icon to display the voice bar.
2. Hold the terminal's microphone near your mouth or other source of sound.
3. Tap the Record button. A beep sounds, instructing you to begin recording.
4. Make your recording.
5. When you are finished, tap the Stop button. Two beeps sound. The new recording appears in the note list or as an embedded icon.

To play a recording, tap it in the list or tap its icon in the note.

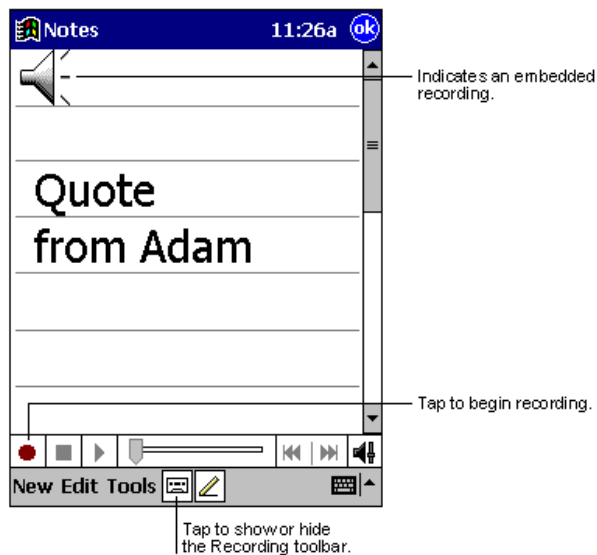
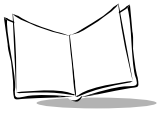



Figure 2-6. Recording Screen



Finding Information

The Find feature locates information. On the  menu, tap **Find**. Enter the text you want to find, select a data type, then tap **Go**.

To find information taking up storage space on your terminal, select **Larger than 64 KB** in **Type**.

You can also use the File Explorer to find files and organize them into folders. On the  menu, tap **Programs**, then **File Explorer**.

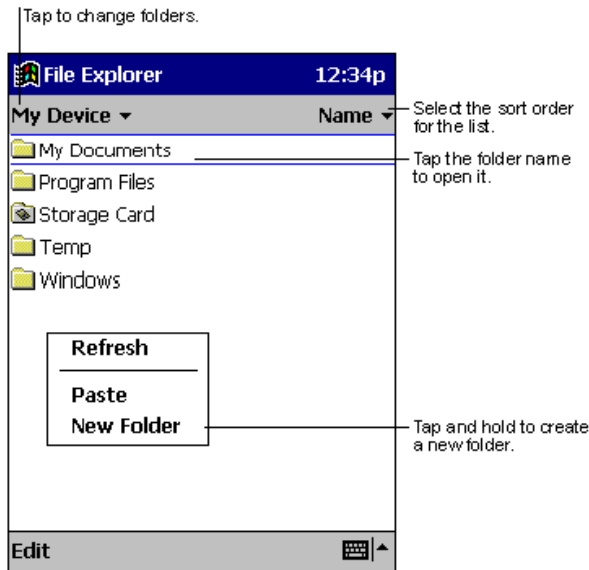

Figure 2-7. File Explorer

Note: To move files in File Explorer, tap and hold the item, then tap **Cut** or **Copy** and **Paste** on the pop-up menu.

Scanning

The PPT 2700 has an integrated scanner which allows you to collect data by scanning 1 or 2 dimensional bar codes. See [Appendix B, Demo Program](#) for a sample scanning application.

To scan bar codes with the PPT 2700:

1. Aim the scan window at the bar code.
2. Press either the right, left, or center scan trigger. Make sure the red scan beam covers the entire bar code. The green scan LED lights and a beep sounds to indicate a successful decode.

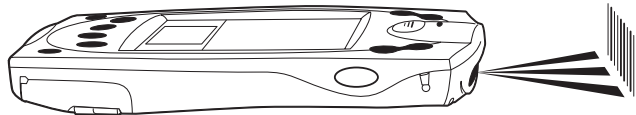

Figure 2-8. Scanning

Scanning PDF417 Bar Codes

The 2D scanning PPT 2700 terminal supports PDF417 bar code scanning. The raster pattern has multiple scanning rows to accommodate the PDF417 symbol's multiple rows.

1. Point the scanner at the bar code and press the trigger.
2. Center the aiming pattern (a spot or slab raster, as programmed) on the bar code.
3. As the raster pattern spreads, keep the pattern in the same horizontal plane as the bar code.

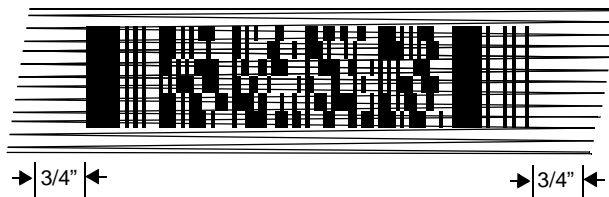
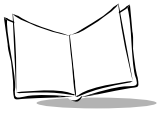

Figure 2-9. Raster Pattern

4. The terminal indicates a successful scan by changing the LED from red to green, beeping one or more times, and/or displaying the bar code data on the screen.



“Tall” PDF Bar Codes

If the PDF417 symbol is “tall,” the vertical scan pattern may not be high enough to cover it.

In this case, try a slow “up and down” scanning motion. With the raster pattern open, move the terminal slowly down toward the bottom of the symbol, keeping the beam horizontal to the rows, then slowly back up toward the top.

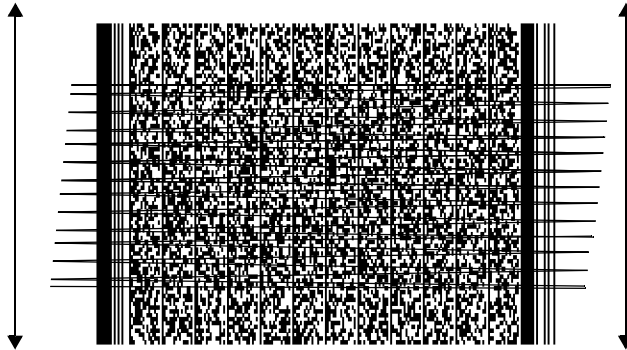

Figure 2-10. Scanning Tall PDF Bar Code

The scan beam does not have to be *perfectly* parallel with the top and bottom of the symbol (up to a 4° tilt will work).

Resetting Your PPT 2700 Terminal

If your PPT 2700 terminal stops responding to input from buttons or the screen, you must reset it by performing a warm or cold boot.

Performing a Warm Boot

A warm boot restarts the terminal and saves all stored records and entries.

Caution

Files that remain open during a warm boot may not be retained.

To perform a warm boot, hold down both the up and down scroll buttons, then press the App 4 button.

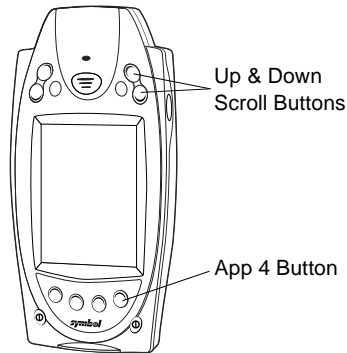

Figure 2-11. Warm Boot Buttons

Performing a Cold Boot

A cold boot also restarts your PPT 2700 terminal, but erases all stored records and entries. *Therefore, never perform a cold boot unless a warm boot does not solve your problem.*

Note: *You can restore any data previously synchronized with your computer during the next ActiveSync operation.*

To perform a cold boot:

1. Remove the battery cover.
2. While holding down the Function button, use the tip of the stylus (or similar object *without* a sharp tip) to gently press the reset button.

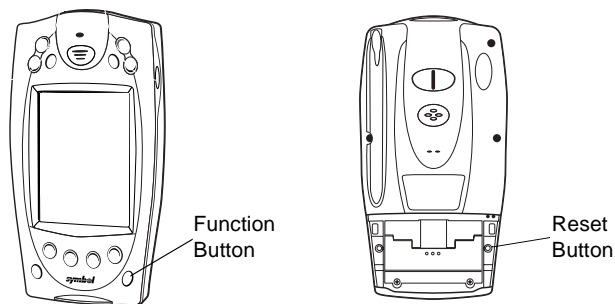
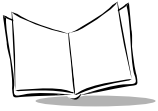

Figure 2-12. Cold Boot Buttons



3. Replace the battery cover and press the Power button.
4. As the terminal initializes its unique Flash File system, the Symbol splash screen displays for about a minute.
5. See [Aligning the Screen](#) on page 1-11 to perform an initial setup of the terminal.

Note: *With a cold boot, the current date and time, formats, preferences, and other settings are restored to their factory default settings.*



Chapter 3

Customizing Your PPT 2700

Introduction

This chapter provides basic instructions for customizing your terminal by adjusting settings and installing additional software.

Adjusting Settings

To view available options for your terminal settings, tap  , **Settings**, then the **Personal** or **System** tab at the bottom of the screen.

You might want to adjust the following:

- Clock: change the time or set alarms
- Buttons: assign applications to the application hardware buttons
- Menus: customize what appears on the  menu and enable a pop-up menu from the **New** button
- Owner Information: enter your contact information
- Password: limit access to your terminal
- Power: maximize battery life
- Today: customize the information displayed on the Today screen.

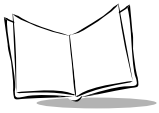

Adding and Removing Programs

Programs pre-installed on your terminal are stored in ROM (read-only memory). You cannot remove, modify, or accidentally lose this software. You may add programs and data files to RAM (random access memory).

In addition to the RAM-based storage standard on Pocket PC terminals, the PPT 2700 is also equipped with a non-volatile Flash-based storage area which can store data (partitions) that can not be corrupted by a cold boot. This Flash area is divided into two categories: Flash File System (FFS) Partitions and Non-FFS Partitions.

FFS Partitions

The PPT 2700 terminal includes three FFS partitions. These partitions appear to the terminal as a hard drive that the OS file system can write files to and read files from. Data is retained even if power is removed.

The three FFS Partitions appear as three separate folders in the Windows CE file system and are as follows:

- **Platform:** The Platform FFS Partition contains Symbol-supplied programs and Dynamic Link Libraries (DLLs). This FFS is configured to include DLLs that control system operation. Since these drivers are required for basic terminal operation, only experienced users should modify the content of this partition.
- **Application:** The Application FFS Partition is used to store application programs needed to operate the terminal. This partition includes the Symbol demo program, which can be overwritten with your own program.
- **Data:** The Data FFS Partition is optional and if present contains user data files generated by your custom programs. The default PPT 2700 image does not contain a Data FFS partition.

Working with FFS Partitions

Because the FFS partitions appear as folders under the Windows CE file system, they can be written to and read like any other folder. For example, an application program can write data to a file located in the Application folder just as it would to the Windows folder. However, the file in the Application folder is in non-volatile storage and is not lost on a cold boot (e.g., when power is removed for a long period of time).

Standard tools such as ActiveSync can be used to copy files to and from the FFS partitions. They appear as the “Application,” “Platform,” and “Data” folders to the ActiveSync explorer.

This is useful when installing applications on the PPT 2700. Applications stored in the Application folder are retained even when the terminal is cold booted, just as the PPT 2700 Demo program is retained in memory.

Windows CE expects certain files to be in the Windows folder, residing in volatile storage. Windows CE maintains the System Registry in volatile storage. There are two device drivers included in the Windows CE image to assist developers in configuring the terminal following a cold boot: **RegMerge** and **CopyFile**.

Regmerge

Regmerge merges registry entries with the System registry at Boot time. During a cold boot **RegMerge** looks for files with a .REG extension on the FFS partition and merges these with the system Registry. The default application partition shipped with the PPT 2700 includes the following example from the file **application.reg**:

```
[HKEY_CURRENT_USER\Software\Symbol\Launcher\Default\Programs\Prog2]
"Name"="\Application\ScanSamp2.exe"
"Description"="Scanner"
"Command"=""
```

CopyFile

CopyFile copies files from one folder to another on a cold boot. Files can be copied from a non-volatile partition (Application or Platform) to the Windows or other volatile partition during a cold re-boot. During a cold boot **CopyFile** looks for files with a .CPY extension on the FFS partition. These files are text files containing the source and destination for the desired files to be copied separated by ">". The following example from the file **application.cpy** is contained on the default application partition shipped with the PPT 2700.

```
;shortcut for the blt.exe
\application\PPT 2700 Demo.lnk > \windows\start menu\PPT 2700 Demo.lnk
\application\Scout Help.lnk > \windows\help\Scout Help.lnk
\application\ScoutSync.htm > \windows\ScoutSync.htm
```

Non-FFS Partitions

Non-FFS Partitions include additional software and data pre-loaded on your terminal that can be upgraded. Unlike FFS Partitions, these partitions are not visible when the operating system is running. They also contain system information. Non-FFS Partitions include the following:

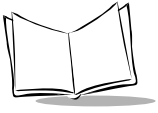

- **Windows CE:** the complete Windows CE operating system is stored on Flash devices. If necessary, the entire OS image may be downloaded to the terminal using files provided by Symbol. The current OS partition on the terminal is included as part of the TCM installation package. Any upgrades must be obtained from Symbol. This partition is mandatory for the PPT 2700.
- **Splash Screen:** a Device Independent Bitmap (DIB) smaller than 16 Kb, displayed as the terminal cold-boots. You may download a customized screen to display (see [Creating a Splash Screen](#) on page 11-19).
- **IPL (Initial Program Loader):** This program interfaces with the host computer and allows you to download via serial cable or cradle any or all of the partitions listed above, as well as updated versions of IPL. Use caution downloading updated IPL versions; incorrect downloading of an IPL causes permanent damage to your terminal. IPL is mandatory for the PPT 2700.

Downloading Partitions to the Terminal

TCM is used to specify a hex destination file for each partition and download each file to the terminal. This download requires a program loader stored on the terminal. The terminal comes with a program loading utility, Initial Program Loader (IPL), stored in the terminal's write-protected flash. See [Chapter 11, Configuring the Terminal](#) for details on using IPL and TCM to download partitions to the PPT 2700.

Adding Programs

Install the appropriate software on your desktop computer before installing it on your terminal.

1. Tap , then **Settings**. On the **System** tab, tap **About**. In the **Version** tab, note the information in **Processor**.
2. Download the program to your desktop computer (or insert the CD or disk that contains the program into your desktop computer). You may see a single *.exe file, a *.zip file, a Setup.exe file, or several versions of files for different device types and processors. Be sure to select the program designed for the Pocket PC and the PPT 2700 processor type.
3. Read any installation instructions, Read Me files, or documentation that comes with the program. Many programs provide special installation instructions.
4. Connect your terminal and desktop computer.
5. Double-click the *.exe file.

If the file is an installer, the installation wizard begins. Follow the directions on the screen. Once the software is installed on your desktop computer, the installer transfers the software to your terminal.

If the file is not an installer, an error message states that the program is valid but it is designed for a different type of computer. Move this file to your terminal. If you cannot find installation instructions for the program in the Read Me file or documentation, use ActiveSync Explore to copy the program file to the Program Files folder on your terminal. For more information on copying files using ActiveSync, see ActiveSync Help.



When installation is complete, tap , Programs, then the program icon to select it.

Adding a Program to the Start Menu

Tap , **Settings, Menus**, the **Start Menu** tab, then the check box for the program.

If you do not see the program listed, either use File Explorer to move the program to the Start Menu folder or use ActiveSync on the desktop computer to create a shortcut to the program and place the shortcut in the Start Menu folder.

Using File Explorer to Add to the Start Menu

1. Tap , **Programs, File Explorer**, and locate the program (tap the folder list, labeled **My Documents** by default, then **My Device** to list all folders on the terminal).
2. Tap and hold the program and tap **Cut** on the pop-up menu.
3. Open the Start Menu folder located in the Windows folder, tap and hold a blank area of the window, and tap **Paste** on the pop-up menu. The program appears on the  menu.

For more information on using File Explorer, see [Finding Information](#) on page 2-10.

Using ActiveSync to Add to the Start Menu

1. Use the Explorer in ActiveSync on your desktop computer to explore your terminal's files and locate the program.
2. Right-click the program, then click Create Shortcut.
3. Move the shortcut to the Start Menu folder in the Windows folder. The shortcut appears on the  menu.

For more information, see ActiveSync Help.

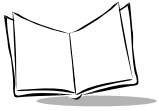

Removing Programs

To remove a program, tap  , then **Settings**. On the **System** tab, tap **Remove Programs**.

If the program does not appear in the list of installed programs, use File Explorer on your terminal to locate the program, tap and hold the program, then tap **Delete** on the pop-up menu.



Chapter 4

Communications

Introduction

The CRD 2700 Cradle serves as an essential data communications device, enabling you to synchronize the information on your PPT 2700 terminal and the ActiveSync® software on your desktop computer. With customized or third party software, it can also be used to synchronize your PPT 2700 terminal with corporate databases and other host computers. Setting up the CRD 2700 cradle involves installing the ActiveSync software to enable synchronization, and connecting your cradle to your computer.

Installing ActiveSync Software

Using ActiveSync technology, you can synchronize the information on your PPT 2700 terminal with the information on your computer. Changes you make on your terminal or desktop computer appear in both places after you synchronize.

With ActiveSync software you can:

- Work with your terminal applications on your computer. ActiveSync duplicates applications on your PPT 2700 terminal (such as Calendar and Contacts) so you can view, enter and modify any data stored on your PPT 2700 terminal.
- Back up the data stored on your PPT 2700 terminal. Synchronization is a one-step procedure that ensures your data is always safe and up-to-date.
- Copy (rather than synchronize) files between your terminal and computer.
- Control when synchronization occurs by selecting a synchronization mode, e.g., you may synchronize continually while the terminal is in the cradle, or only when you select the synchronize command.

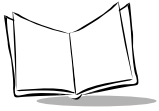

- Select the types of information to synchronize, and control how much data is synchronized.

Performing an ActiveSync for the First Time

The first time you synchronize your data, you need to enter user information on both the PPT 2700 terminal and desktop computer. Once you enter this information and synchronize, you don't need to enter this information again.

Note: You must perform your first ActiveSync operation with a local, direct connection, rather than using a modem.

Performing ActiveSync using the Synchronization Cable

To perform an ActiveSync operation for the first time using the synchronization cable:

1. After installing the ActiveSync software, restart your desktop computer.
2. Insert the cable into the bottom of the terminal.

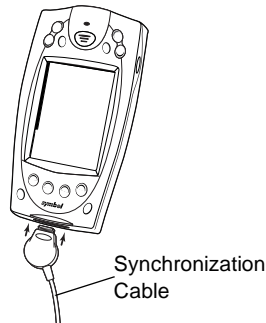

Figure 4-1. Inserting the Cable in the Terminal

3. Connect the other end of the cable to the serial communications port on your computer.

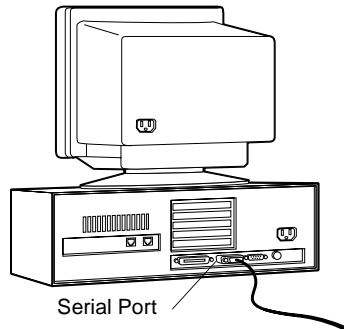

Figure 4-2. Connecting the Synchronization Cable to the Computer

Note: *The synchronization cable requires a dedicated port. It cannot share a port with an internal modem or other device. If you are unsure about the location of the serial port on your computer, refer to the user's manual supplied with the computer.*

4. On the desktop computer, enter a name for your PPT 2700 terminal and click the Next button. Follow the instructions on the screen to set up a partnership that allows synchronization of information between the two computers. Items to be synchronized may be customized, and you may select to synchronize automatically upon connect.

Note: *Every PPT 2700 terminal should have a unique name. Never try to synchronize more than one PPT 2700 terminal to the same user name.*

Performing ActiveSync using the Cradle

To perform an ActiveSync operation for the first time using the cradle:

1. After installing the ActiveSync software, restart your desktop computer.

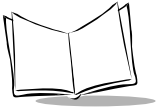

2. Connect your CRD 2700 cradle to your computer by plugging the cable from the cradle into the serial communications port on your computer.

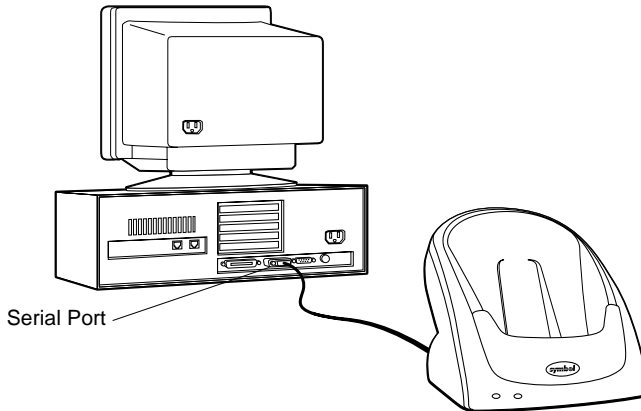

Figure 4-3. Connecting the Cradle to the Computer

Note: *The CRD 2700 cable requires a dedicated port. It cannot share a port with an internal modem or other device. If you are unsure about the location of the serial port on your computer, refer to the user's manual supplied with the computer.*

3. Turn on the PPT 2700 terminal and slide it into the cradle.

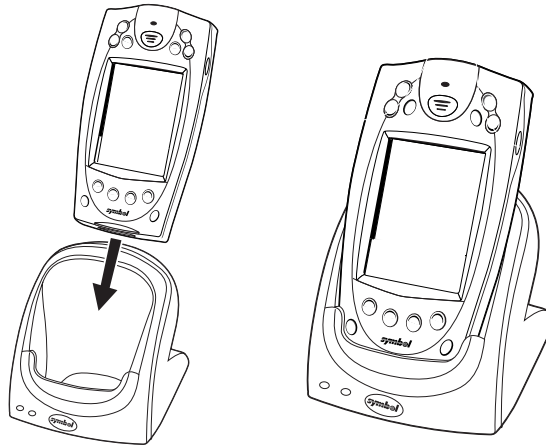

Figure 4-4. Inserting the Terminal in the Cradle

The curved edge on the bottom of the PPT 2700 terminal should align smoothly with the cradle when it is inserted properly.

4. On the desktop computer, enter a name for your PPT 2700 terminal and click the **Next** button. Follow the instructions on the screen to set up a partnership that allows synchronization of information between the two computers. Items to be synchronized may be customized, and you may select to synchronize continuously as information changes, upon connection, or manually by clicking the Sync button on the toolbar of your desktop computer.

Note: *Every PPT 2700 terminal should have a unique name. Never try to synchronize more than one PPT 2700 terminal to the same user name.*

Performing Subsequent ActiveSync Operations

After you complete the first ActiveSync operation, you just need to place the terminal in the connected cradle or connect the synchronization cable and synchronization occurs automatically.

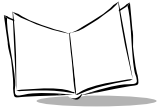

Performing a Remote ActiveSync

You can also sync your PPT 2700 remotely using a modem. See [Creating a Modem Connection to a Network](#) on page 7-4 to set up your terminal for a modem ActiveSync.

Before leaving your desktop computer, prepare the computer for a remote ActiveSync:

1. Start ActiveSync on your desktop computer.
2. On the **File** menu, select **Connection Settings**.
3. Select **Allow network (Ethernet) and Remote Access Service (RAS) server connection with this desktop computer**.
4. Leave your computer on and logged on.

To remotely sync your PPT 2700 terminal with your desktop computer:

1. Insert the terminal in the modem cradle, or attach the MDM3000 Modem Module. If using the cradle, set the Sync Select switch on the back of the cradle to the Modem position.
2. On the PPT 2700, select , **Programs, Connections**.
3. Tap your connection icon.
4. Enter your user name, domain, and password, and tap **Connect**.



Chapter 5 *Applications*

Introduction

Your PPT 2700 terminal includes Calendar, Contacts, Tasks, Inbox, and Notes applications. You can use these programs individually or together. For example, e-mail addresses stored in Contacts can be used to address e-mail messages in Inbox.

Using ActiveSync, you can synchronize information in these applications between your desktop computer and your terminal. Each time you synchronize, ActiveSync compares the changes you made on your terminal and desktop computer and updates both with the latest information. For information on using ActiveSync, see [Chapter 4, *Communications*](#), and ActiveSync Help on the desktop computer.

You can switch to any of these programs by tapping them on the  menu.

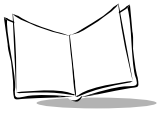

Calendar

Use Calendar to schedule appointments such as meetings. You can view your appointments in different ways (Agenda, Day, Week, Month, and Year) and easily change views using the View menu.

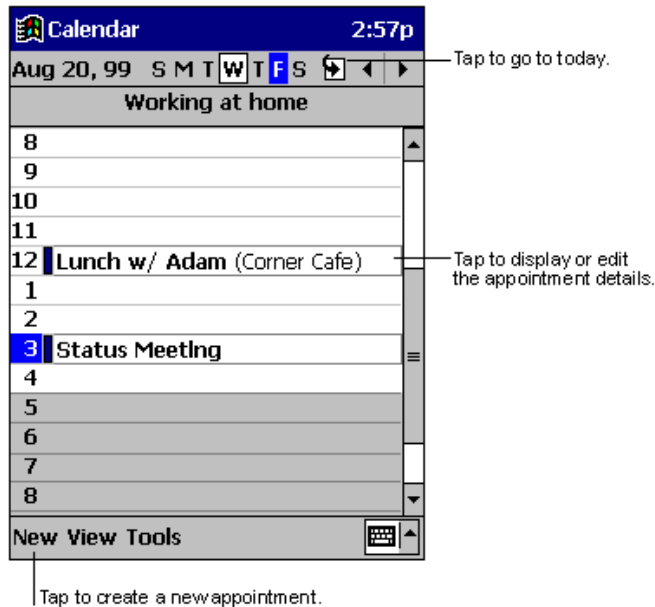



Figure 5-1. Calendar Application

Note: You can customize the Calendar display, such as changing the first day of the week, by tapping **Options** on the **Tools** menu.

Creating Appointments

To create an appointment:

1. To select Calendar, press the App1 button or select Calendar from the  menu.
2. If you are in Day or Week view, tap the desired date and time for the appointment.



3. Tap **New**.

Figure 5-2. Entering an Appointment

4. Using the input panel, enter the subject and a location. Tap first to select the field.
5. If needed, tap the date and time to change them.
6. Enter other desired information. Hide the input panel to see all available fields.
7. To add notes, tap the **Notes** tab. You can enter text, draw, or create a recording. For more information on creating notes, see [Notes](#) on page 5-11.
8. When finished, tap **OK** to return to the calendar.

Note: If you select **Remind me** in an appointment, your terminal notifies you according to the options set in , *Settings, Personal tab, Sounds & Reminders*.

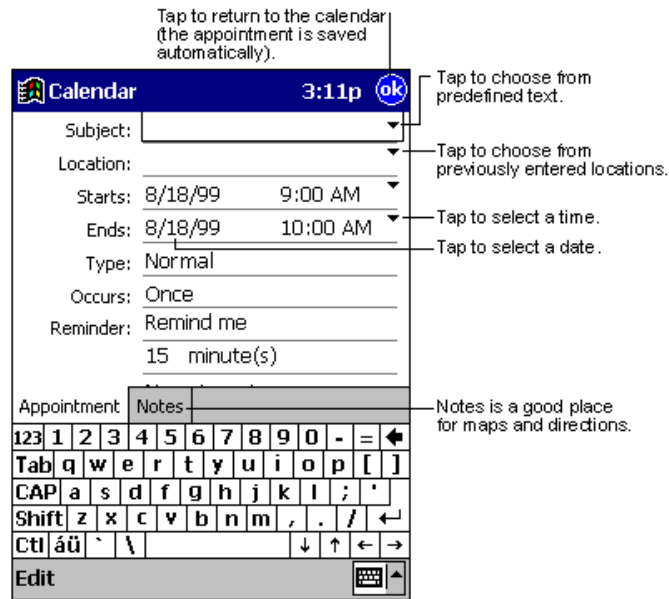

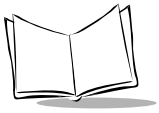
Using the Summary Screen

When you tap an appointment in Calendar, a summary screen displays. Tap the top of the summary screen to change the appointment.

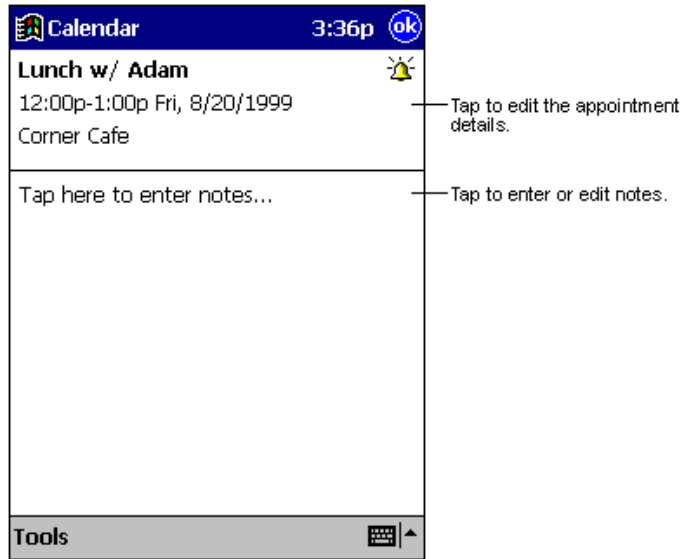

Figure 5-3. Appointment Summary Screen

Creating Meeting Requests

You can use Calendar to set up meetings with users of Outlook 2000. The meeting notice is created automatically and sent either when you synchronize Inbox or when you connect to your e-mail server. Indicate how you want meeting requests sent by tapping **Tools**, then **Options**. If you send and receive e-mail messages through ActiveSync, select **ActiveSync**.

To schedule a meeting:

1. Create an appointment.
2. In the appointment details, hide the input panel, then tap **Attendees**.
3. From the list of e-mail addresses you've entered in Contacts, select the meeting attendees.

The meeting notice is created and placed in the Outbox folder. For more information on sending and receiving meeting requests, see Calendar Help and Inbox Help on your terminal.

Contacts

Contacts maintains a list of associates and friends so that you can easily locate information at home or on the road. Using the infrared (IR) port, you can share Contacts information with other terminal users.

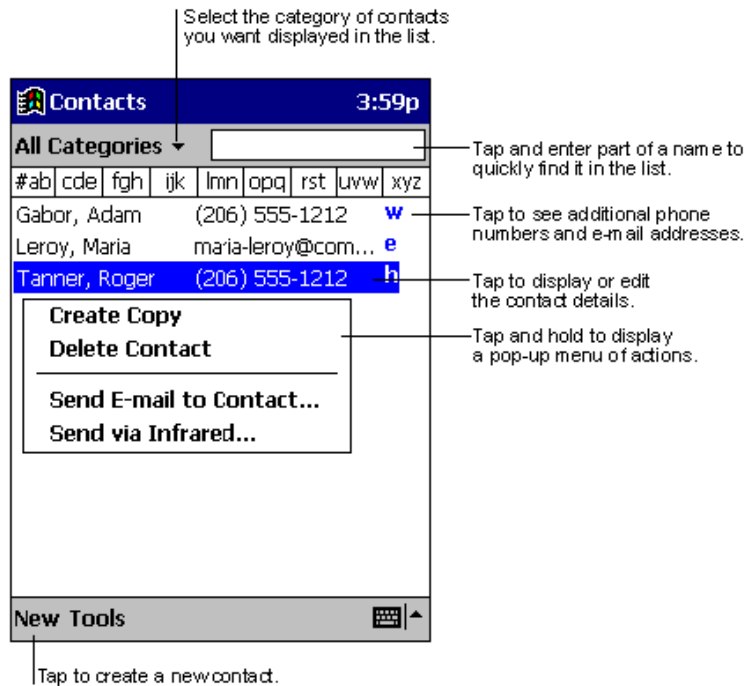
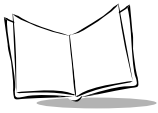

Figure 5-4. Contact Application

Note: To change the way information is listed, tap **Tools**, then **Options**.

To create a contact:



1. Tap **New**.

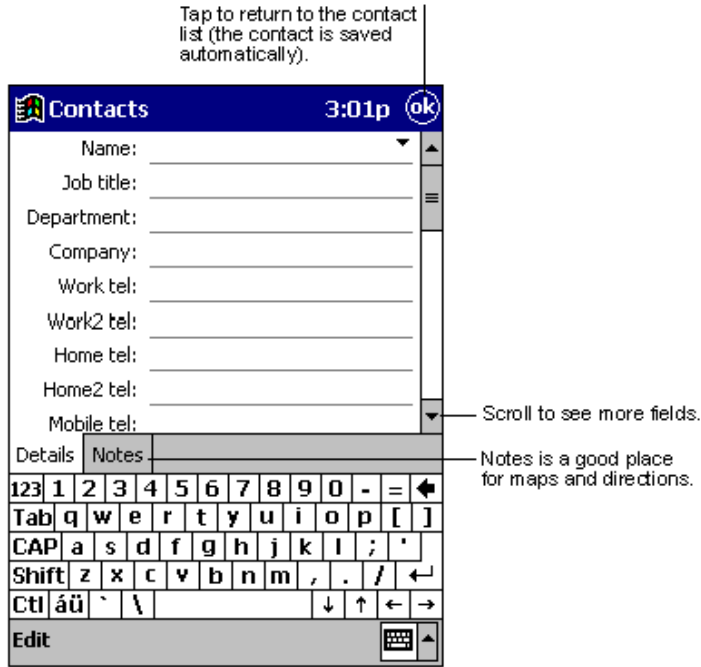

Figure 5-5. Creating a Contact

- Using the input panel, enter a name and other contact information. Scroll down to see all fields.
- To assign the contact to a category, scroll to and tap **Categories**. Select a category from the list. In the contact list, you can display contacts by category.
- To add notes, tap the **Notes** tab. You can enter text, draw, or create a recording. For more information on creating notes, see [Notes](#) on page 5-11.
- When finished, tap **OK** to return to the contact list.

Using the Summary Screen

When you tap a contact in the contact list, a summary screen displays.

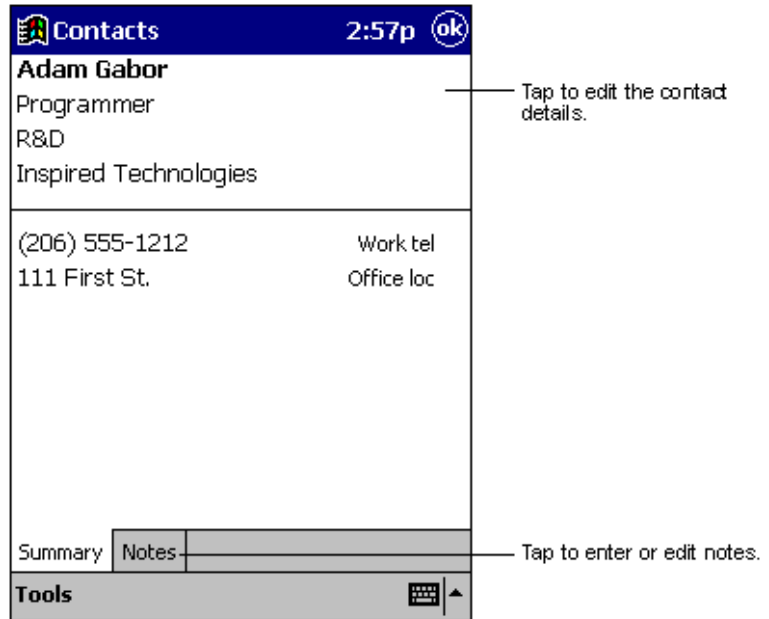
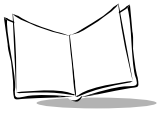

Figure 5-6. Contacts Summary Screen



Tasks

Use Tasks to keep a “to do” list. In the task list, overdue tasks display in bold.

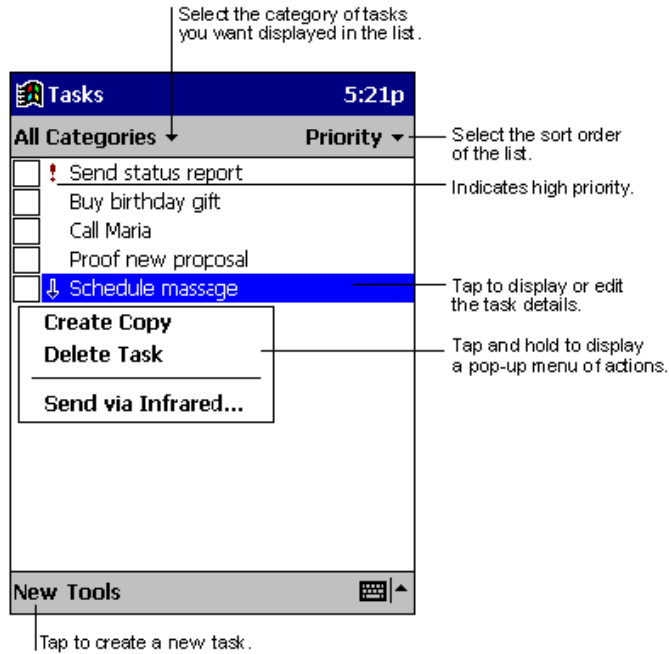

Figure 5-7. Task Application

Note: To change the way information displays in the list, tap **Tools**, then **Options**.

To create a task:

1. Tap **New**.

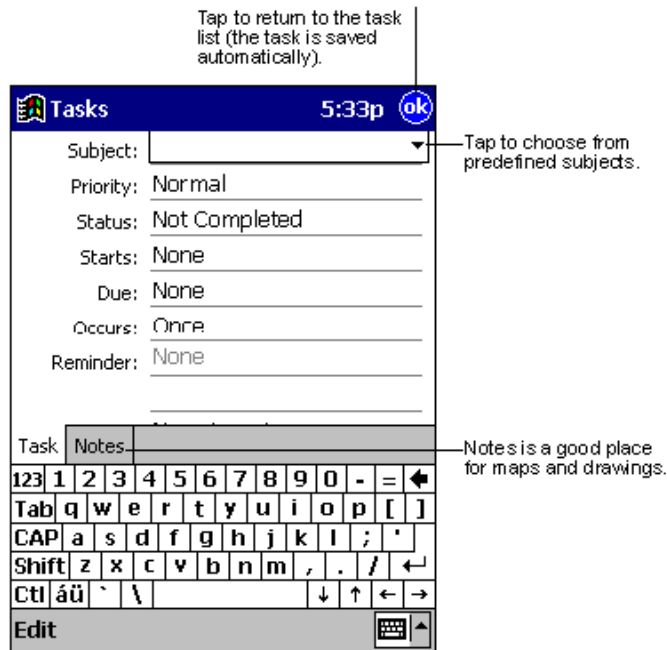
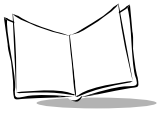

Figure 5-8. Creating a Task

2. Using the input panel, enter a description.
3. You can enter a start date and due date or enter other information by first tapping the field. If the input panel is open, hide it to see all available fields.
4. To assign the task to a category, tap **Categories** and select a category from the list. In the task list, you can display tasks by category.
5. To add notes, tap the **Notes** tab. You can enter text, draw, or create a recording. For more information on creating notes, see [Notes](#) on page 5-11.
6. Tap **OK** to return to the task list.

Note: To create a task with only a subject, tap **Entry Bar** on the **Tools** menu. Then tap **Tap here** to add a new task and enter your task information.



Using the Summary Screen

When you tap a task in the task list, a summary screen displays.

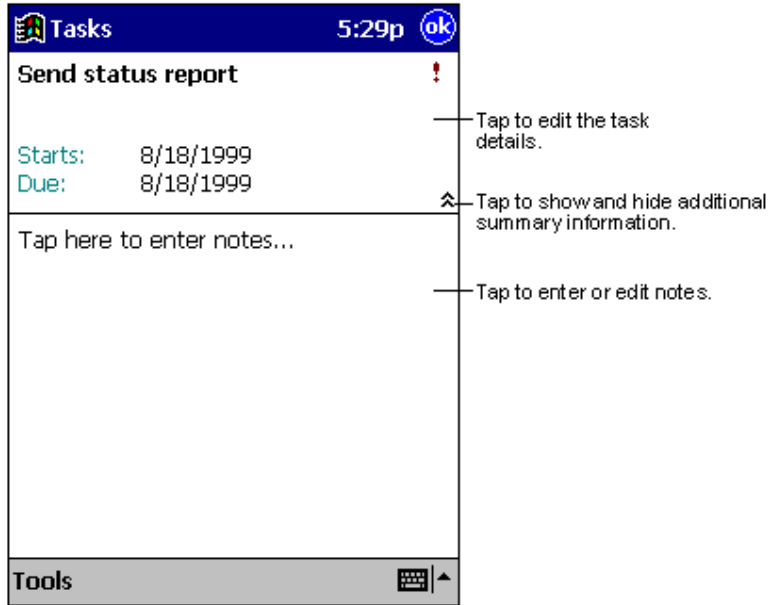

Figure 5-9. Task Summary Screen

Notes

Capture thoughts, reminders, ideas, drawings, and phone numbers with Notes. You can create a written note or a recording. You can also include a recording in a note. If a note is open when you create the recording, it is included in the note as an icon. If the note list is displayed, it is created as a stand-alone recording.

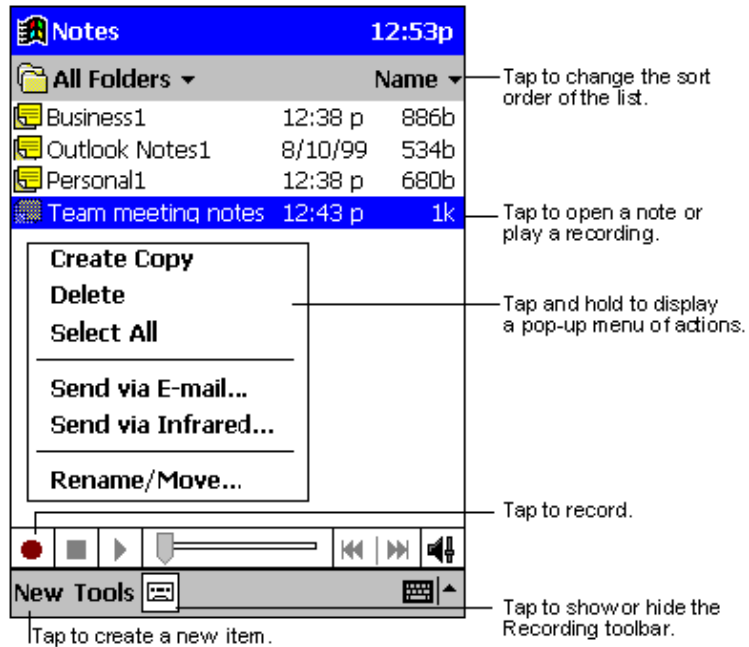
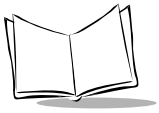

Figure 5-10. Notes Application



To create a note:

1. Tap **New**.
2. Create your note by writing, drawing, typing, and recording. For more information about using the input panel, writing and drawing on the screen, and creating recordings, see [Chapter 2, Operating the PPT 2700](#).

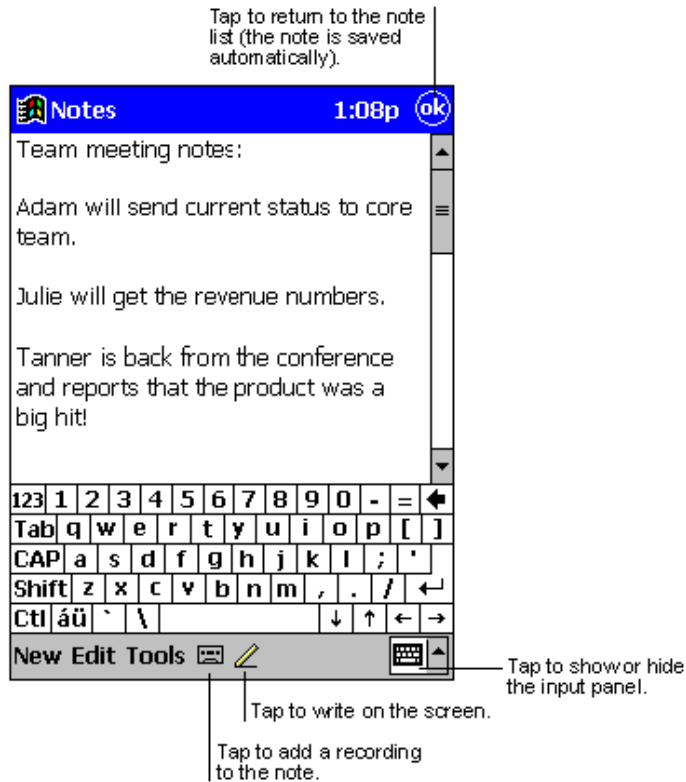

Figure 5-11. Creating a Note

Inbox

Use Inbox to send and receive e-mail messages in the following ways:

- Synchronize e-mail messages with Microsoft Exchange or Outlook 2000 on your desktop computer.
- Send and receive e-mail messages by connecting directly to an e-mail server through an Internet service provider (ISP) or a network.

Synchronizing E-mail Messages

To synchronize e-mail messages, first enable Inbox synchronization in ActiveSync options. For information on enabling Inbox synchronization, see ActiveSync Help on the desktop computer.

During synchronization:

- E-mail messages are copied from the Inbox folder of Exchange or Outlook 2000 on your desktop computer to the Inbox folder on your terminal. The e-mail messages on the two computers are linked, so when you delete an e-mail message on your terminal, it's also deleted from your desktop computer the next time you synchronize.
- E-mail messages in the Outbox folder on your terminal are transferred to Exchange or Outlook 2000, then sent from those programs.

Note: *You can also synchronize e-mail messages with your desktop computer from a remote location. For more information, see [Chapter 7, Connections](#).*

Connecting Directly to an E-mail Server

You can also send and receive e-mail messages by connecting to an e-mail server using a modem or network card connected to your terminal. You'll need to set up a remote connection to a network or an ISP, and a connection to your e-mail server. For more information, see [Chapter 7, Connections](#).

When you connect to the e-mail server, new messages are downloaded to the terminal Inbox folder, messages in the terminal Outbox folder are sent, and messages that were deleted on the e-mail server are removed from the terminal Inbox.

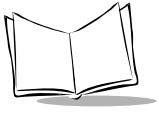

Messages that you receive directly from an e-mail server are linked to your e-mail server rather than your desktop computer. When you delete a message on your terminal, it's also deleted from the e-mail server the next time you connect.

You can work online or offline. When working online, you read and respond to messages while connected to the e-mail server. Messages are sent as soon as you tap **Send**, which saves space on your terminal.

When working offline, once you've downloaded new message headers or partial messages, you can disconnect from the e-mail server, then decide which messages to download completely. The next time you connect, Inbox downloads the complete messages you've marked for retrieval and sends the messages you've composed.

Using the Message List

Messages you receive display in the message list. By default, the most recently received messages are listed first.

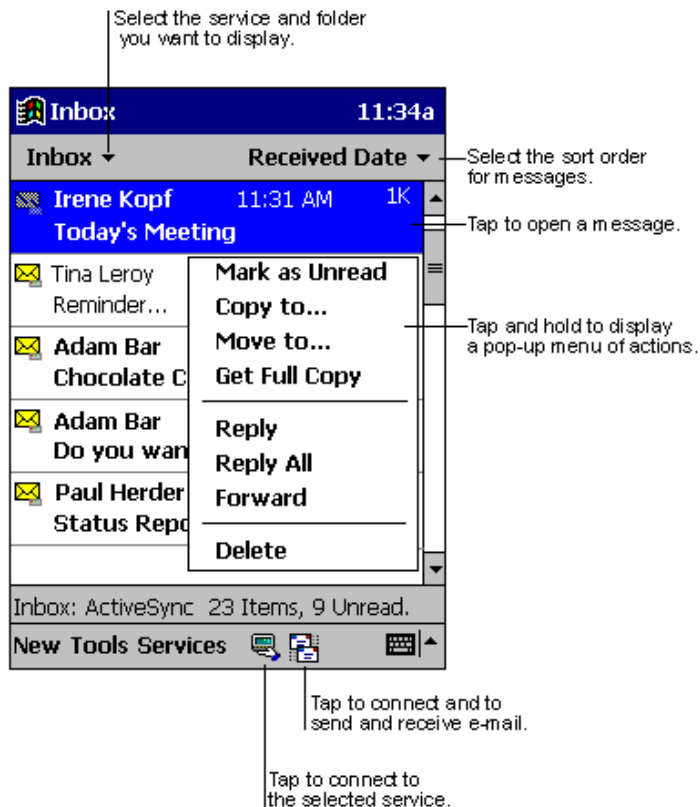
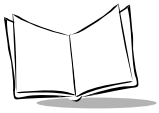

Figure 5-12. Inbox Application



When you receive a message, tap it in the list to open it. Unread messages display in bold.

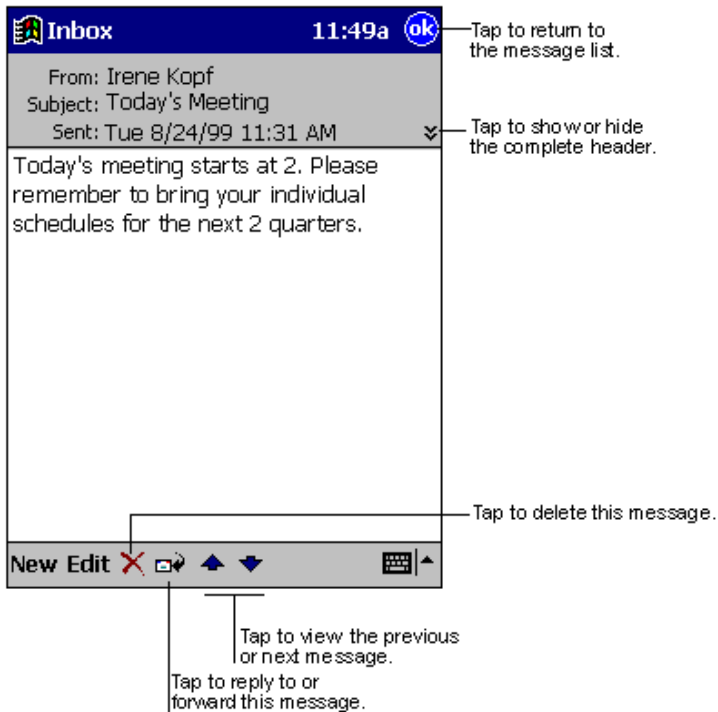

Figure 5-13. Viewing a Message

When you connect to your e-mail server or synchronize with your desktop computer, Inbox downloads only the first 100 lines of each new message by default. No e-mail attachments are downloaded. The original messages remain on the e-mail server or your desktop computer.

You can mark the messages that you want to retrieve completely the next time you synchronize or connect to your e-mail server. In the message list, tap and hold the message you want to retrieve. On the pop-up menu, tap **Get Full Copy**. The icons in the Inbox message list indicates message status.

You must download a full message before you can view its attachments. Attachments appear as icons in a window pane at the bottom of the message. Tapping an attachment icon opens the attachment if it was fully downloaded or marks it for download the next time you synchronize or connect to your e-mail server.

You specify your downloading preferences when you set up the service or select your synchronization options. You can change them at any time:

- Change options for Inbox synchronization using ActiveSync options. For more information, see ActiveSync Help.
- Change options for direct e-mail server connections in Inbox on your terminal. Tap **Tools**, then **Options**. On the **Service** tab, tap the service you want to change.

Creating E-mail Messages

To create an e-mail message:

1. Tap New.
2. Enter an e-mail address in **To**, or select a name from the contact list by tapping the **Address Book** button. All e-mail addresses entered in the e-mail fields in Contacts appear in the Address Book.

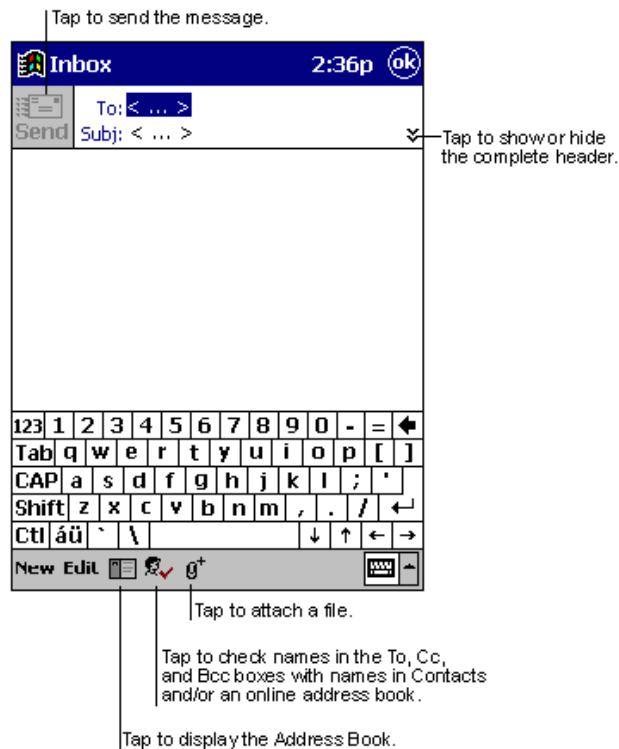
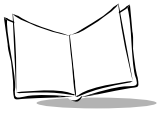

Figure 5-14. Creating a Message



3. Compose your message. Tap **Send** when you're finished.

The message is placed in the Outbox folder on your terminal and is delivered in one of two ways:

- It is transferred to the Outbox folder in Exchange or Outlook 2000 on your desktop computer and sent the next time you synchronize.
- It is transferred to your e-mail server the next time you connect. In Inbox, make sure the appropriate service is selected on the Services menu. Then tap the **Connect** button (or **Connect** on the **Services** menu).

Managing E-mail Messages and Folders

By default, messages are displayed in one of four folders for each service you've created: Inbox, Deleted (local), Outbox, and Sent. The Deleted folder contains messages that have been deleted on the terminal. The behavior of the Deleted and Sent folders depends on the options you selected. In the message list, tap **Tools**, then **Options**. On the **Message** tab, select your options.

To organize messages into additional folders, tap **Tools**, then **New Folder** to create new folders. To move or copy a message to another folder, in the message list, tap and hold the message, then tap **Move to** or **Copy to** on the pop-up menu.

Folder Behavior with ActiveSync and Direct Connection to Server

If you move e-mail messages into a folder you create, the link is broken between these e-mail messages and their copies on the desktop computer. When you synchronize, the e-mail messages in the folder you created are not synchronized. These e-mail messages missing from the terminal Inbox folder are deleted from the Inbox folder on the desktop computer so that both Inbox folders match. This prevents you from getting duplicate copies of an e-mail message, and you can only access the e-mail messages you move out of Inbox from the terminal.

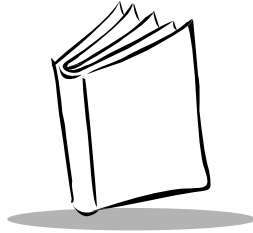

Chapter 6

Pocket Internet Explorer

Introduction

With Pocket Internet Explorer, you can view Web pages in the following ways:

- During synchronization with your desktop computer, download your favorite links, mobile favorites, and mobile channels stored in the Mobile Favorites subfolder in Internet Explorer on the desktop computer.
- Connect to an Internet service provider (ISP) or network and browse the Web. First create the connection (see [Chapter 7, Connections](#)).

To select Pocket Internet Explorer, tap  , then Internet Explorer.

Mobile Favorites

Items stored in the Mobile Favorites subfolder in the Favorites folder in Internet Explorer on your desktop computer are synchronized with your terminal. This folder was created automatically when you installed ActiveSync.

Favorite Links

Synchronization updates the list of favorite links both in the Mobile Favorites folder on your desktop computer and in Pocket Internet Explorer on your terminal. Unless you mark the favorite link as a mobile favorite, only the link is downloaded to your terminal; you must connect to your ISP or network to view the content. For more information on synchronization, see ActiveSync Help on the desktop computer.

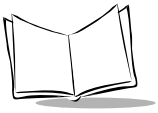

Creating Mobile Favorites

If you are using Microsoft Internet Explorer 5 on your desktop computer, you can download mobile favorites. (You can install Microsoft Internet Explorer 5 from the Extras folder on the ActiveSync CD.) Synchronizing mobile favorites downloads Web content to your terminal so you can view Web pages while disconnected from your ISP and desktop computer.

Use the Internet Explorer 5 plug-in installed with ActiveSync to create mobile favorites:

1. In Internet Explorer 5 on your desktop computer, click **Tools**, then **Create Mobile Favorite**.
2. To change the link name, enter a new name in the **Name** box.
3. If desired, select a desired update schedule in **Update**.
4. Click **OK**. Internet Explorer downloads the latest version of the Web page to your desktop computer.
5. To download the pages linked to the mobile favorite you just created, in Internet Explorer on the desktop computer, right-click the mobile favorite, then click **Properties**. On the **Download** tab, specify the number of links deep you want to download. To conserve terminal memory, only go one level deep.
6. Synchronize your terminal and desktop computer. Mobile favorites stored in the Mobile Favorites folder in Internet Explorer 5 are downloaded to your terminal.

If you did not specify an update schedule in step 3, you must manually download content to keep the information updated on your desktop computer and terminal. Before synchronizing, in Internet Explorer on your desktop computer, click **Tools**, then **Synchronize**. Note the last time content was downloaded to the desktop computer; if necessary, manually download content.

You can add a button to the Internet Explorer toolbar for creating mobile favorites. In Internet Explorer 5 on your desktop computer, click **View**, **Toolbars**, then **Customize**.

Saving Memory on your Terminal

Mobile favorites take up storage memory on your terminal. To minimize the amount of memory used:

- In the settings for the Favorites information type in ActiveSync options, turn off pictures and sounds or stop some mobile favorites from downloading. For more information, see ActiveSync Help.

- Limit the number of downloaded linked pages. In Internet Explorer on the desktop computer, right-click the mobile favorite you want to change, then select **Properties**. On the **Download** tab, specify 0 or 1 for the number of linked pages to download.

Channels

Channels are Web sites designed for offline viewing on your terminal. You can use mobile channels on your PPT 2700.

Using Mobile Channels

Mobile channels are sites you subscribe to on your desktop computer. They are stored in the Channels subfolder in the Mobile Favorites folder in Internet Explorer 4.0 or later and are downloaded to your terminal during synchronization.

To see a list of mobile channels you can subscribe to at no fee, visit the Windows CE Mobile Channel List Web page (<http://www.microsoft.com/windowsce/channels>). Click the **Add Mobile Channel** button and select **Make available offline** to download the channel to your desktop computer. The mobile channel is transferred to your terminal when you synchronize.

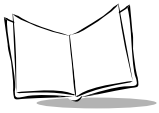

Using Pocket Internet Explorer

With Pocket Internet Explorer, you can browse mobile favorites and channels downloaded to your terminal without connecting to the Internet. You can also connect to the Internet through an ISP or a network connection and browse the Web.



Figure 6-1. Pocket Internet Explorer

To view mobile favorites and channels, tap the **Favorites** button to display your list of favorites, then tap the mobile favorite or channel you want to view.

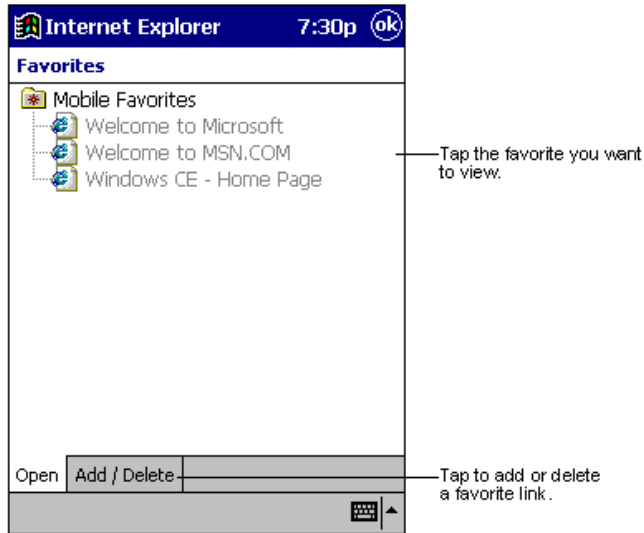
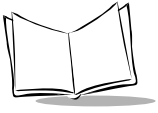



Figure 6-2. Mobile Favorites

You'll see the page that was downloaded the last time you synchronized with your desktop computer. If the page is not on your terminal, the favorite is dimmed. Synchronize with your desktop computer again to download the page to your terminal, or connect to the Internet to view the page.



Browsing the Web

1. Connect to the Internet or your network in one of the following ways:
 - Using Connections, as described in [Chapter 7](#). Then select Pocket Internet Explorer from the  menu.
 - In Pocket Internet Explorer. To select a service or type of connection, tap **Tools**, then **Options**. Tap the **Connections** tab and select the connection type. Then, when you want to connect to the selected service, tap **Tools**, then **Connect**.

Note: *Pocket Internet Explorer can automatically connect to the Internet when you attempt to access a page not stored on your terminal. Specify a connection in the **Connection** tab in **Options**, then select **Access remote content automatically**.*

2. Once connected, go to a specific Web page in one of the following ways:
 - Tap the **Favorites** button, then tap the favorite you want to view.
 - Tap **View**, then **Address Bar**. In the address bar at the top of the screen, enter the Web address and tap **Go**. Tap the arrow to choose from previously entered addresses.
3. To end the connection, tap **Tools**, then **Disconnect**.

Note: *To add a favorite link while using the terminal, go to the Web page you want to add, tap the **Favorites** button, tap the **Add/Delete** tab, tap the **Add** button, and enter a name for the favorite link.*



Chapter 7

Connections

Introduction

Your terminal can exchange information with other Windows-powered devices using its infrared (IR) port. In addition to using a cradle, cable, or IR port to connect your terminal to your desktop computer, you can also:

- Connect to your Internet service provider (ISP) to send and receive e-mail messages using Inbox and view Web pages using Pocket Internet Explorer. See [Connecting to an ISP](#) on page 7-2. The communication software for creating an ISP connection is already installed on your terminal. Your service provider provides software needed to install other services, such as paging and fax services.
- Create a modem connection to connect to the network at your office to send and receive e-mail messages using Inbox, view Web pages using Pocket Internet Explorer, and synchronize with your desktop computer. See [Connecting to Your Network](#) on page 7-4.
- Wirelessly via Spectrum24 LAN, or a CDPD/GSM wireless network. See [Chapter 8, Spectrum24 Network Configuration](#) or [Chapter 9, Wireless Wide Area Network Configuration](#).
- Connect to your desktop computer to synchronize remotely. See ActiveSync Help on your desktop computer or Connections Help on your terminal.

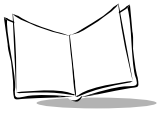

Transferring Items Using Infrared

Using infrared (IR), you can send and receive information, such as contacts and appointments, between two Windows-powered devices.

To send information:

1. Open the program where you created the item you want to send and locate the item in the list. To send more than one item, drag the stylus across the items you want to send.
2. Align the IR ports so that they are unobstructed and within a close range.
3. Tap and hold the item, and tap **Send via Infrared** on the pop-up menu.

Note: You can also send items, but not folders, from File Explorer. Tap and hold the item, then tap **Send via Infrared** on the pop-up menu.

To receive information:

1. Align the IR ports so that they are unobstructed and within a close range.
2. Tap , **Programs**, then **Infrared Receive**.

Note: You can also receive items from Tasks, Contacts, Calendar, and Notes by tapping **Tools**, then **Receive via Infrared** in list view.

Connecting to an ISP

Create a modem connection to connect to your ISP. Once connected, you can send and receive e-mail messages and view Web pages.

To create a modem connection to an ISP, use the modem cradle or snap-on modem. See the *Quick Reference Guide* for each device for connection information.

1. Get the ISP dial-up access telephone number, user name, password, and TCP/IP settings from your ISP. Some ISPs require information in front of the user name, such as MSN/username.
2. Tap , then **Settings**. On the **Connections** tab, tap **Modem**.

3. Tap **New connection**.

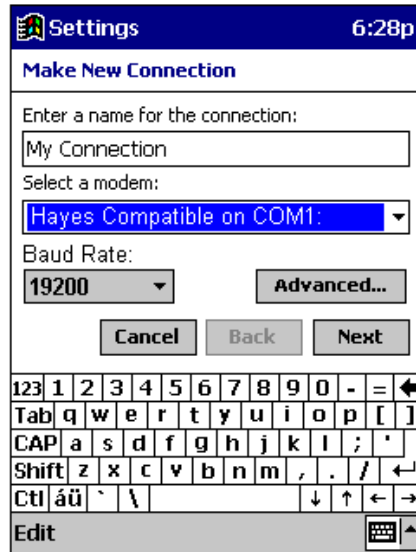

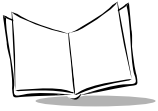

Figure 7-1. Creating a Modem Connection

4. Enter a name for the connection.
5. In the **Select a modem** list, select Hayes Compatible on COM1.
6. You should not need to change any settings in **Advanced**. Most ISPs now use a server-assigned address. If the ISP you are connecting to does not use a server-assigned address, tap **Advanced**, then the **TCP/IP** tab and enter the address. When finished, tap **OK**, then **Next**.
7. Enter the access phone number and tap **Next**.
8. Select other desired options, and tap **Finish**.
9. On the **Dialing** tab, specify your current location and phone type (most phone lines are tone). These settings apply to all connections you create. Tap **OK** to return to **Settings**.

After you create the connection, it appears in , **Programs, Connections**. To start the connection, remove your terminal from the cradle, tap the connection icon, enter your user name and password, and tap **Connect**. Once connected, you can:



- Send and receive e-mail messages using Inbox. You first must provide the information it needs to communicate with the e-mail server. For instructions, see [Connecting Directly to an E-mail Server](#) on page 7-6.
- Visit Web pages using Pocket Internet Explorer. For more information, see [Chapter 6, Pocket Internet Explorer](#).

To change connection settings, return to Modem Settings. Tap the Modem link at the bottom of the **Connections** folder. To return to the **Connections** folder, tap the Connections link.

Connecting to Your Network

If you have access to a network, you can send e-mail messages, view intranet pages, synchronize your terminal, and possibly access the Internet. You can connect to your network in one of the following ways:

- Create a modem connection using an RAS account. Your network administrator must first set up an RAS account for you.
- Wirelessly via Spectrum24 LAN, or a CDPD/GSM wireless network. See [Chapter 8, Spectrum24 Network Configuration](#) or [Chapter 9, Wireless Wide Area Network Configuration](#).

Creating a Modem Connection to a Network

To create a modem connection, use the modem cradle or snap-on modem. See the *Quick Reference Guide* for each device for connection information.

1. Obtain the dial-up access telephone number, user name, password, domain name, and TCP/IP settings from your network administrator.
2. Tap , then **Settings**. On the **Connections** tab, tap **Modem**.



3. Tap **New connection**.

Figure 7-2. Creating a Modem Connection

4. Enter a name for the connection.
5. Select Hayes Compatible on COM1.
6. You should not need to change any settings in **Advanced**. Most servers use a server-assigned address. If not, tap **Advanced**, then the **TCP/IP** tab and enter the address. When finished, tap **OK**, then **Next**.
7. Enter the access phone number, and tap **Next**.
8. Select other desired options, and tap **Finish**.
9. On the **Dialing** tab, specify your current location and phone type (most phone lines are tone). These settings apply to all connections you create. Tap **OK** to return to **Settings**.

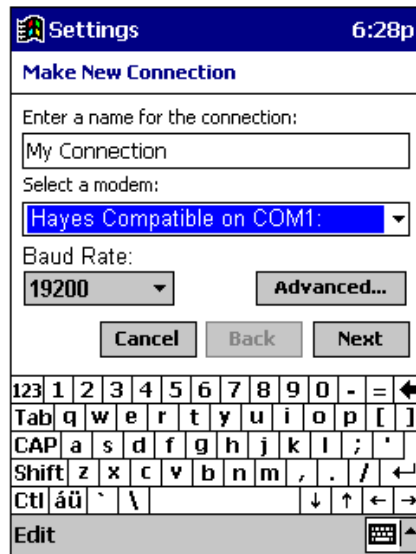

When you have created the connection, it appears in , **Programs, Connections**. To start the connection, remove your terminal from the cradle, tap the connection icon, enter your user name, domain, and password, and tap **Connect**. Once connected, you can:

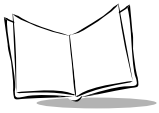
- Send and receive e-mail messages using Inbox. Before you can use Inbox, provide the information it needs to communicate with the e-mail server. See [Connecting Directly to an E-mail Server](#) on page 7-6.



- Visit Internet or intranet Web pages using Pocket Internet Explorer. You may need to set up a proxy server to visit Internet Web pages. For more information on setting up a proxy server, see Pocket Internet Explorer Help on the terminal.
- Synchronize. For more information, see ActiveSync Help on the desktop computer.

Disconnecting

If you started the connection from a program such as Inbox or Pocket Internet Explorer, disconnect from that program first. Tap , then **Today**. Tap  or  at the bottom of the screen, then **Disconnect**. To end a network connection, remove the card from your terminal.

Connecting Directly to an E-mail Server

You can set up a connection to an e-mail server to send and receive e-mail messages using a modem or network connection and Inbox on your terminal.

Note: *The ISP or network must use a POP3 e-mail server and an SMTP gateway.*

Inbox does not currently support connecting with proprietary e-mail protocols, such as AOL and MSN™. However, you can still access the Internet through these services. There may be third-party programs available to enable you to send and receive e-mail messages through proprietary protocols.

You can use multiple e-mail services to receive your messages. For each e-mail service you intend to use, first set up and name the e-mail service. If you use the same service to connect to different mailboxes, set up and name each mailbox connection.

Setting Up an E-mail Service

1. In Inbox on your terminal, tap **Services**, then **New Service**.

The screenshot shows a terminal window titled 'Inbox' with a time of 6:15p. The main content area is titled 'Service Name'. Below this title, there are three input fields: 'Service type:' with a dropdown menu showing 'IMAP4 Mail', 'Service name:' with a text box containing 'IMAP4 Mail', and a third empty text box. At the bottom of the form are three buttons: 'Cancel', 'Back', and 'Next'. Below the form is a standard terminal keyboard layout with rows for numbers, letters, and function keys. At the very bottom is an 'Edit' button with a keyboard icon.

Figure 7-3. Setting Up E-mail Service

2. Select POP3 as the service type, name the service, and tap **Next**. Ask your ISP or network administrator which service type to select.
3. If you have already created a connection, select it from the **Connection** list. If you have not, select **Create new connection** and follow the steps in the wizard. When you return to this screen at the end of the wizard, select the connection you created from the **Connection** list.

Follow the directions on the screen. For an explanation of a screen, tap **Start**, then **Help**. When finished, tap **Services**, then **Connect** to connect to your e-mail server. For more information on using the Inbox program, see [Inbox](#) on page 5-13.



Getting Help Connecting

See the following for more connection information:

- [Inbox on page 5-13](#)
- Online Help on the terminal. Tap  , then **Help**. Tap **View, All Installed Help**, then **Inbox** or **Connections**.
- ActiveSync Help on the desktop computer. In ActiveSync, click **Microsoft ActiveSync Help** on the Help menu.
- [Maintenance and Troubleshooting](#) on page 12-1.

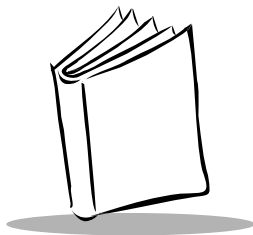

Chapter 8

Spectrum24 Network Configuration

Introduction

Wireless LANs allow PPT 2700 series terminals to communicate wirelessly, and to send captured data “real time” to a host device. Terminals and their supported network types are:

Terminal	Network Technology
PPT 274x	Spectrum24 (LAN)
PPT 2733	CDPD (WAN)
PPT 2734	GSM (WAN)

Before a terminal can be used on a Spectrum24 LAN, or a CDPD/GSM wireless network, your facility must be set up with the equipment required to run the wireless LAN and the terminal must be properly configured. Refer to the documentation which came with your access points for instructions on setting up the required hardware.

To configure a PPT 2733 for a CDPD wireless network, or a PPT 2734 for a GSM wireless network, see [Chapter 9, Wireless Wide Area Network Configuration](#)

NICTT

The PPT 274X terminal supports two utilities that configure and monitor the Spectrum24 connection. The Network Interface Card Task Tray (NICTT) utility checks the status of Symbol Spectrum24 WLAN adapter operating within a Spectrum24 wireless network. The Spectrum24 Settings Control Panel Applet utility configures the Spectrum24 adapter.

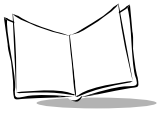







NICTT provides signal, transmission quality and power management status for the Spectrum24 network connection. The NICTT taskbar tray icons convey signal strength and service quality information. NICTT property pages allow you to view driver and firmware revision data and view terminal transmission and signal quality.

NICTT Task Tray

To display the NICTT icon at the top of the **Start** menu:

1. Tap **Start** to display the Start menu.
2. Tap **Programs**.
3. Tap **NICTT**.

The NICTT task tray icon appears at the top of the **Start** menu, and indicates terminal signal strength as follows.

Icon	Status
	Excellent signal strength
	Very good signal strength
	Good signal strength
	Fair signal strength
	Poor signal strength
	Out-of-network range (not associated)
	Adapter not found

Tap the icon above to display NICTT properties.

Spectrum24 Settings Control Panel Applet

The Spectrum24 Settings Control Panel Applet allows you to view and edit Spectrum24 terminal settings.

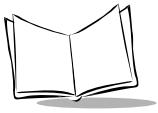

Configuring the PPT 2740/2742 (1 and 2 MB radio)

Using NICTT on the PPT 2740/2742

The NICTT property pages contain a variety of wireless network and service quality information. Select help for a detailed explanation within each NICTT property page.

General Property Page

Before the PPT 2740/2742 can be used, it must be properly configured with the correct ESS ID. The ESS ID identifies the radio network and is used to differentiate between different radio networks. All PPT 2740/2742 terminals on the same network must be set up with the same ESS ID Code. The ESS ID on the terminal is the same as that of the access points in your facility.

The *General* page displays driver firmware and revision information, and allows you to change the ESSID or NetId depending on the NIC 802.11 or Spring firmware.

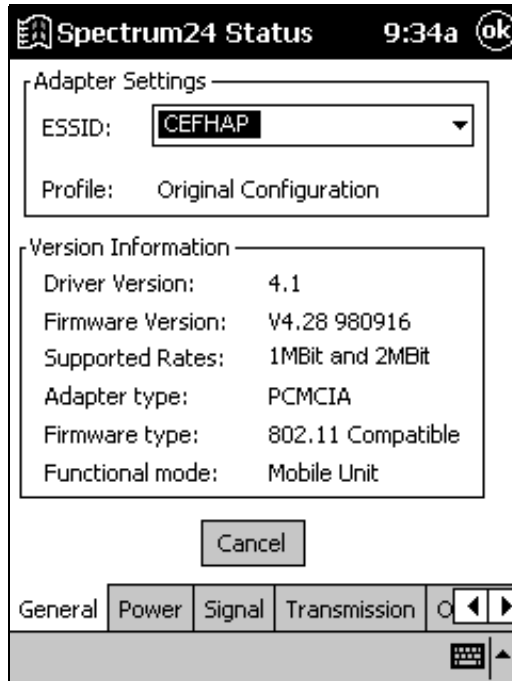

Figure 8-1. General Properties Page

Note: A PC Card adapter installation displays PCMCIA as the Adapter Type.

Power Mode Property Page

The Spectrum24 WLAN adapter Power Mode management properties allows automatic or manual setting of the adapter power management mode from Continuous Access Mode (CAM) to Power Save Polling (PSP) mode and controls the adapter Beacon Algorithm. Do NOT select the **Switch mode based on power source** option.

CAM mode is not a valid operating mode for the PPT 2740/2742, and should only be used for short duration testing. AC power supplies power to the battery charger only.

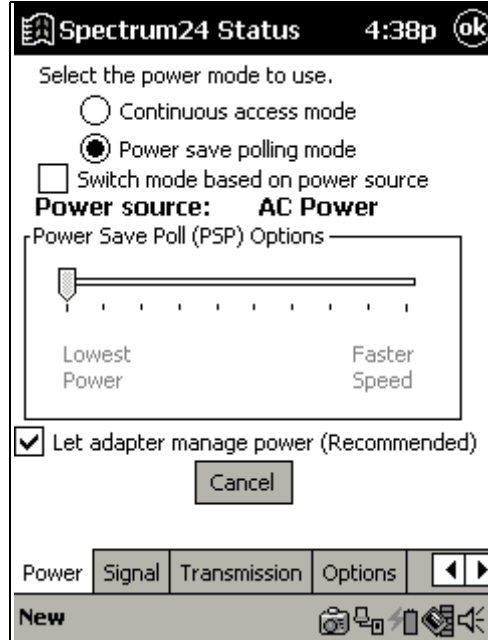
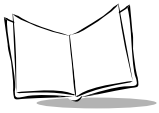

Figure 8-2. Power Property Page



Signal Strength Property Page

The *Signal* page displays a real-time graph of the signal quality being received by the adapter, and displays a description of the signal quality.

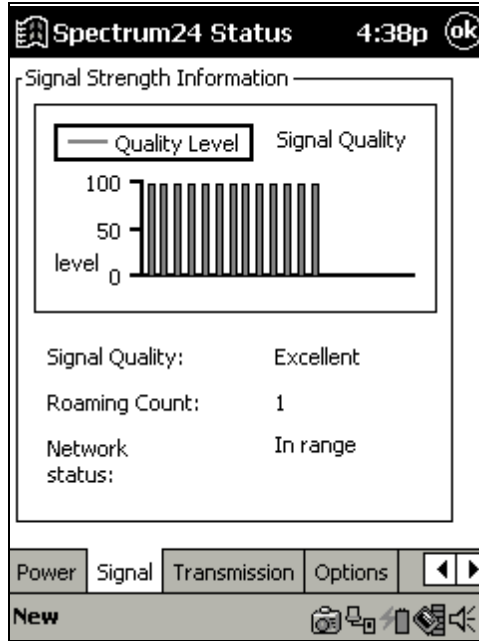

Figure 8-3. Signal Property Page

Transmission Quality Property Page

The *Transmission* page displays a real-time graph as a series of ICMP ping tests initiated by the user. The transmission quality test does not run all the time because it consumes network bandwidth.

The transmission quality test also displays a description of the transmission quality.

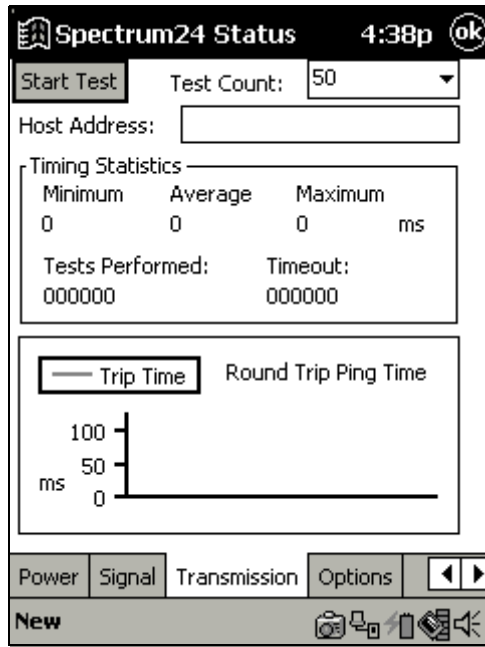
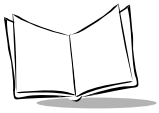

Figure 8-4. Transmission Property Page

Note: Load and configure the TCP/IP protocol before running the Transmission Quality test.



Options Property Page

The *Options* page controls system sounds and whether specified settings are temporary.

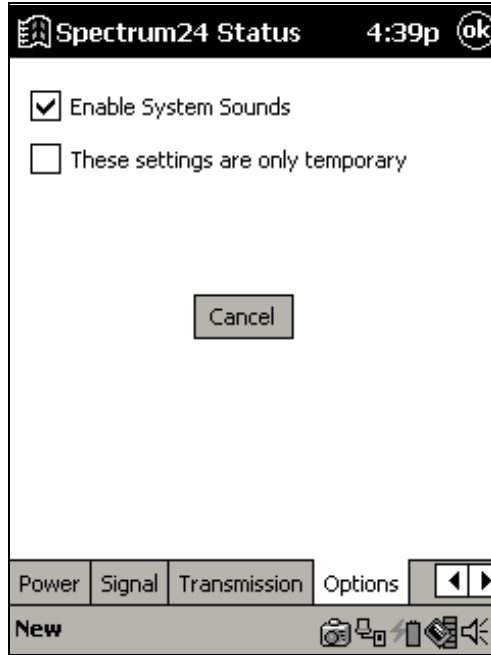

Figure 8-5. Options Property Page

Enable System Sounds

You can enable or disable NICTT system sounds. NICTT uses standard wav-table sounds supplied by the Windows operating system. NICTT plays a wav file when it detects the PPT 2740/2742 roaming between Spectrum24 APs, and also during a transmission test.

Temporary Settings

Check *These settings are only temporary* to use temporary values only until the computer system reboots. When not checked, any value entered in NICTT is saved and used even after the system is rebooted.

Using Spectrum24 Settings Control Panel Applet for the PPT 2740/2742

The Spectrum24 Settings Control Panel Applet allows you to view and edit Spectrum24 terminal settings. On the Start menu, select **Settings**, the **System** tab, then **Spectrum24 Settings**. The *Spectrum24 WLAN Easy Setup* dialog box appears. This dialog box allows you to set a new 802.11 ESSID or Spring NetId.

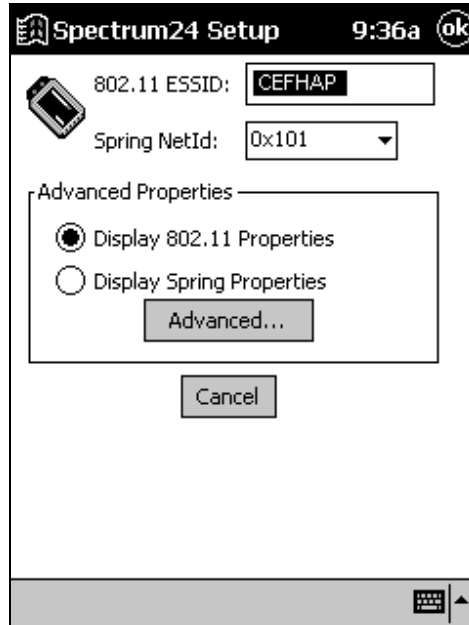
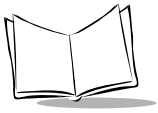

Figure 8-6. Easy Setup Dialog Box

Selecting the Advanced button allows you to view or edit 802.11 and Spring parameters using the *Spectrum24 WLAN Advanced Properties* dialog box.



Mobile Unit Properties

Spectrum24 Setup 9:38a **ok**

802.11 Mobile Unit Settings

ESSID:

RTS Threshold:

International Roaming

Preferred BSS ID

Mandatory BSS ID

Power Management

Power Mode:

Beacon Algorithm:

Minimum: Maximum:

Mobile Unit: WLAN Adapter

Figure 8-7. Mobile Unit Property Page

The *Mobile Unit* page configures NIC ESSID or NetId (depending on the 802.11 or Spring firmware in the terminal), Power Management, Request To Send (RTS) Threshold, Preferred BSS ID, and Mandatory BSS ID values. These values control how the terminal associates and consumes power in the MU mode. The *Spring Mobile Unit* page is similar to the 802.11.

To use the Power Management settings in the Spectrum24 Settings Control Panel Applet, disable Power Mode Management capabilities in NICTT as follows:

1. In NICTT select the *Power* tab.

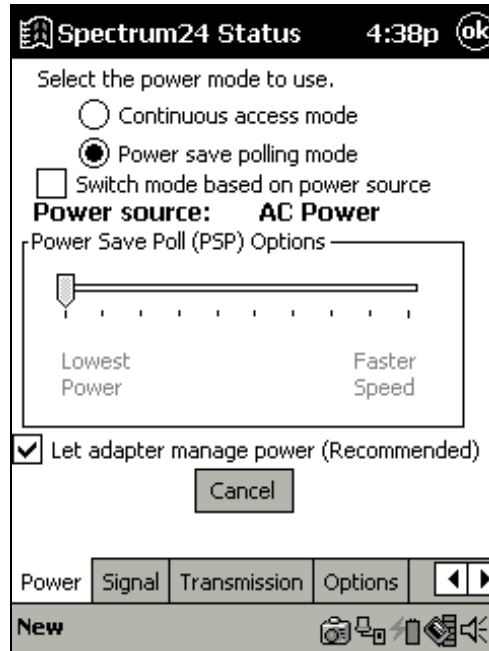
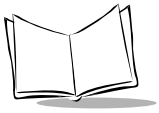

Figure 8-8. Power Property Page

2. If checked, uncheck *Switch power mode based on power source*.
3. Select *Power save polling mode*.
4. Uncheck *Let adapter manage power (recommended)*.
5. Select the *General* tab.
6. Uncheck *These settings are only temporary*.
7. Tap OK.
8. Reboot the terminal.



WLAN Adapter Settings

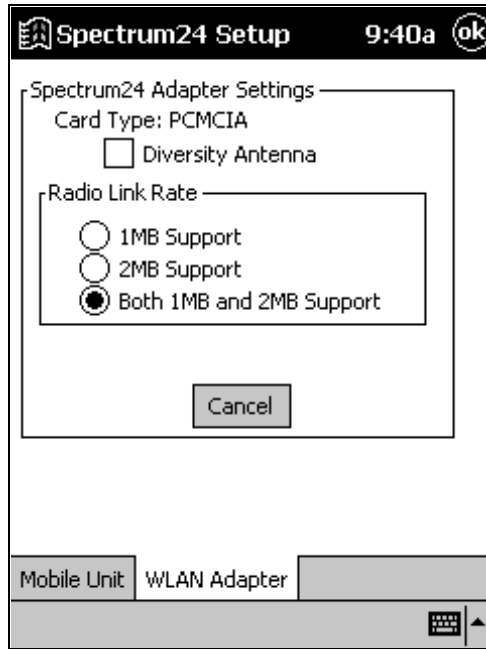

Figure 8-9. WLAN Adapter Property Page

On the *WLAN Adapter* page, the Card Type (the only visible field), interrupt Number, IO Port Address and Memory Base Address are automatically selected in a Plug and Play environment and are not visible (unless a PC Card is installed). Select the Radio Link Rate here along with the antenna options.

Configuring the PPT 2746 (11 MB radio)

Using NICTT on the PPT 2746

The NICTT property pages contain a variety of wireless network and service quality information.

General Property Page

The *General* page on the Spectrum24 Status screen allows you to set the operational mode and ESSID.

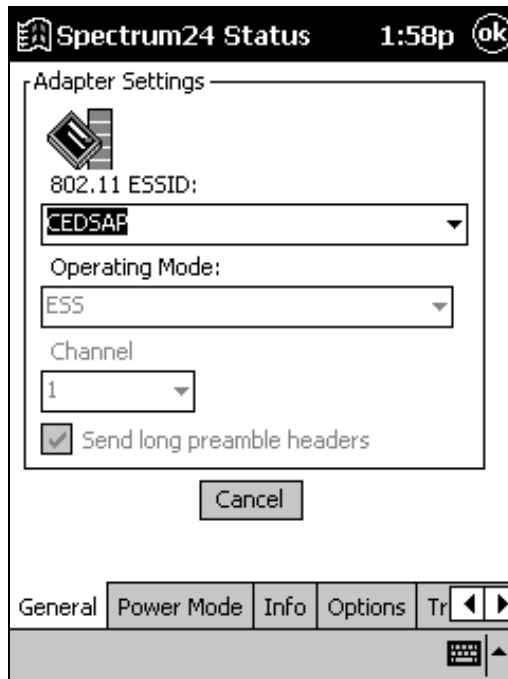
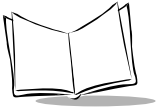

Figure 8-10. General Properties Page

Note: *The operating mode and ESS ID set in NICTT override those settings in NICInfo and NCPA.*



Use the Operating Mode pull-down menu to select one of the following options:

- **ESS (802.11 Station)** enables the terminal to transmit and receive data with an access point. Data rate is based on transmit retries. This is the default.
- **IBSS (802.11 Ad Hoc)** enables terminals to form their own local network where they can communicate peer-to-peer without access points. Use IBSS to create networks within established cells. Terminals take turns generating beacons and handling probe responses. The terminal starting the IBSS network (i.e., the first terminal transmitting a beacon) sets the channel number.

If you select IBSS, the **Signal** tab (on the far right) turns into the **Peers** tab. Select **Peers** to view the BSS ID or MAC address of other terminals in the network, their operating mode (PSP or CAM), transmit rate, supported data rate, and the length of time each terminal has been out of the IBSS network. Select **Refresh** to update the **Peers** page to the latest network performance and membership data.

- Select **Pseudo IBSS (Proprietary Ad Hoc)** for the highest throughput in an IBSS network for terminal testing. Pseudo IBSS does not support PSP terminals and does not use beacons or authentication. Select the channel for the network from the Channel drop-down menu. Each terminal must be on the same channel. If you select Pseudo IBSS, the **Signal** and **Peers** tabs are no longer available. Pseudo IBSS is not recommended as a normal operational mode or for terminals operating on battery power.

Enter a 32-character (maximum) string NIC ESS ID (802.11 Extended Service Set Identifier) in the **ESSID** field to identify the wireless network. The ESS ID assigned to the terminal must match the ESS ID of the access point.

Power Mode Property Page

The Power Mode management properties allows automatic or manual setting of the adapter power management mode.

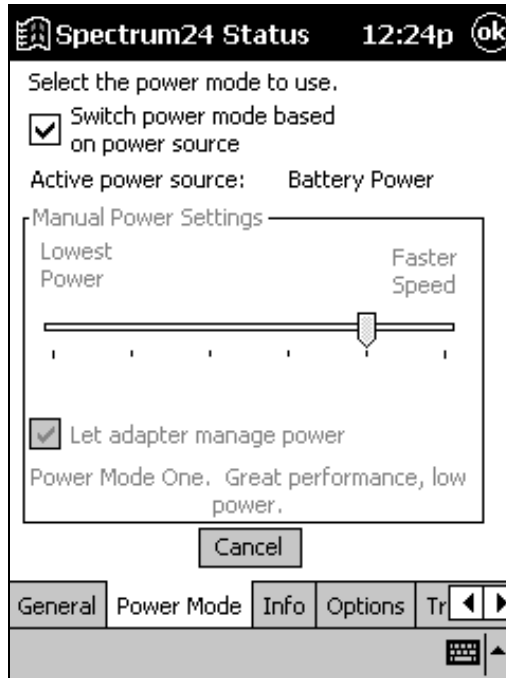
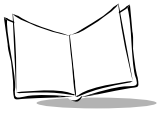

Figure 8-11. Power Property Page

- Select **Continuous Access Mode (CAM)** or **Power Save Polling (PSP)** mode. CAM yields the best performance but uses the most power. This mode is recommended for systems using AC power. PSP saves power, so is recommended for systems running on battery power.
- Use the sliding scale in the **Manual Power Settings** field to set a PSP performance index (1 to 5) suited to the intended operation of the terminal. The selected PSP setting is described below the sliding scale.
- Check the **Switch power mode based on power source** checkbox to automatically transition the system from PSP mode when on battery power to CAM when on AC power. Clear this checkbox to prevent NICTT from transitioning from PSP to CAM when AC power is detected.



- Check the **Let adapter manage power** checkbox to let the adapter select a low power mode. Clear this checkbox to enable the power slider and set the power levels.

Info Property Page

Use the *Info* page to view version and operating mode information.

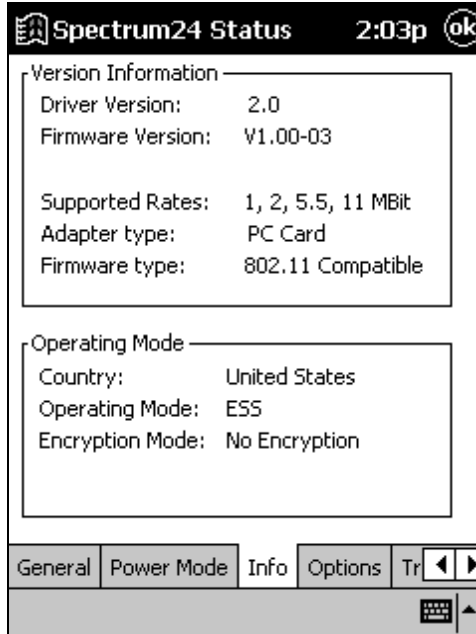

Figure 8-12. Info Property Page

The **Version Information** field displays driver version, adapter firmware version, supported data rates, adapter type and firmware type. Use this information to determine if upgrading NIC firmware could result in better performance.

The **Operating Mode** field displays the terminal's operating country, operating mode (ESS, IBSS Ad Hoc or Pseudo Ad Hoc), and Encryption mode.

Note: *The operating mode set in NICTT overrides the operating mode settings made in NCPA and NICInfo.*

Options Property Page

The *Options* page controls system sounds and whether specified settings are temporary.

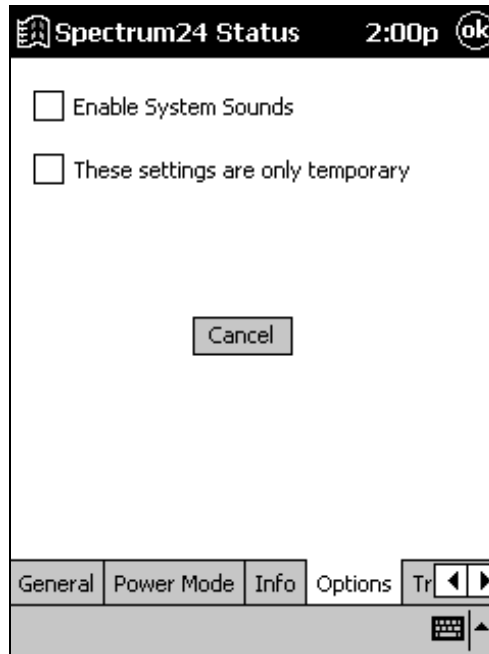

Figure 8-13. Options Property Page

Enable System Sounds

You can enable or disable NICTT system sounds. NICTT uses standard wav-table sounds supplied by the Windows operating system. NICTT plays a wav file when it detects the PPT 2746 roaming between APs, and also when it pings a host computer.

You may change NICTT wave files using the Windows Control Panel Sounds applet. There are two entries for NICTT: Spectrum24 NICTT Ping and Spectrum24 NICTT Roam. Select a wave file in the **Sounds** window for the audible response tone. The standard wave files shipped with NICTT have the following format:

SSxxxn.wav

Where **xxxx** is either ping or roam and **n** is the identity of the file.

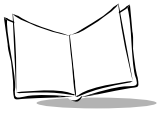

Temporary Settings

Check *These settings are only temporary* to use temporary values only until the computer system reboots. When not checked, any value entered in NICTT is saved and used even after the system is rebooted.

Transmission Quality Property Page

The *Transmission* page tests transmission quality from the client computer to a networked computer.

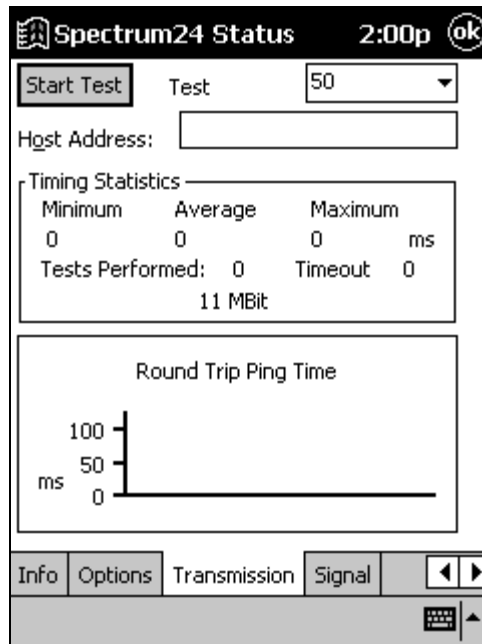

Figure 8-14. Transmission Property Page

To test transmission quality, send an ICMP ping packet across the network to a selected address or host name. Configure the following parameters to conduct a transmission test:

1. Enter an IP address in the **Host Address** field as a dotted string (122.78.3.141) or as a host name. Domain Name Server (DNS) services are required to use host names, or an error message displays indicating the host name could not be found. The TCP/IP protocol must also be installed.

2. Select the number of times to run the test from the **Test** pull-down menu.
3. Select the **Start Test** button to begin the test. Each ping displays the round-trip time for the ICMP ping to complete. The minimum, maximum, and average values display as results. A real-time graph indicates the round-trip time of each packet.

Signal Strength Property Page

The *Signal* page displays signal transmission quality from the terminal to the associated access point. Signal quality indicates how clearly the terminal can hear the associated access point.

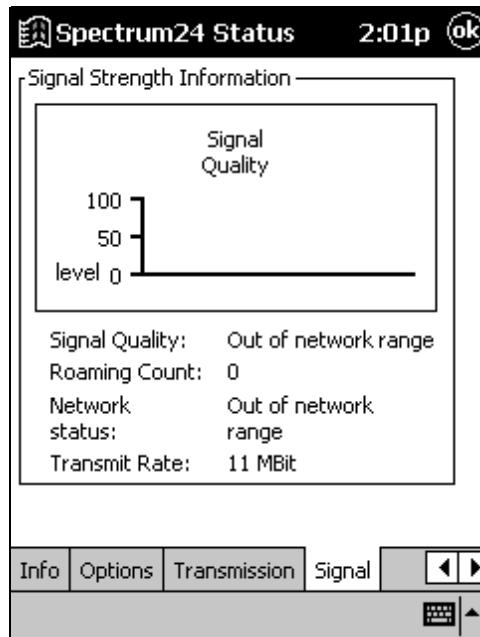
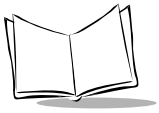

Figure 8-15. Signal Property Page

Note: *This tab does not display if IBSS or Pseudo IBSS are selected as the operating mode from the General property page.*

The **Signal** Property Page displays the following information:



- A graph displays signal quality from 0 to 100 percent. The terminal continuously looks for a stronger signal from a different access point on the network, and roams to that access point if the quality of the radio signal drops below an acceptable level.
- The bottom of the **Signal** page displays the current signal quality, the number of times the terminal has roamed, the current data rate, and the network in-range status.

Using Spectrum24 Settings Control Panel Applet for PPT 2746

The Spectrum24 Settings Control Panel Applet allows you to view and edit Spectrum24 NIC settings. During initial installation, the HR WLAN Setup screen appears. This allows you to set the ESSID and finish the installation.

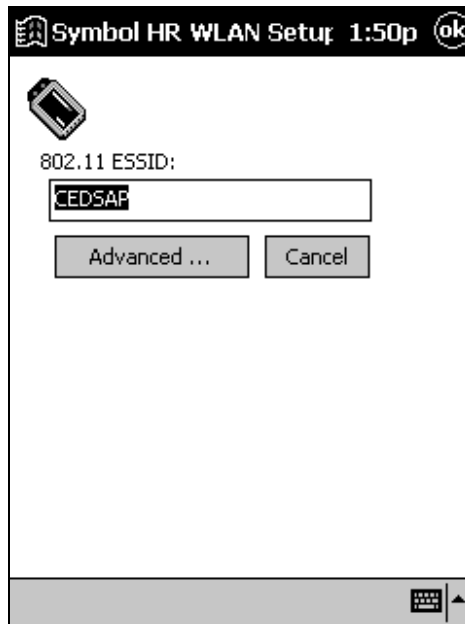

Figure 8-16. WLAN Setup Screen

Enter an ESSID (802.11 Extended Service Set Identifier) matching the access point ESSID to enable the terminal to communicate with the access point. This value is a unique 32-

character (maximum) string that identifies the wireless local area network. If the ESSID is unknown, ask the IS department for assistance.

Advanced Settings

Only system administrators should modify the advanced settings. Select the **Advanced** button to view and edit the **Advanced** property pages and create a password for these pages. The Advanced property pages control all aspects of the terminal, including Mobile Unit settings, Power settings, Encryption settings, and WLAN Adapter hardware settings.

Mobile Unit Properties

Symbol HR WLAN Setup 1:51p (ok)

Operating Mode:
 ESS

802.11 ESSID:
 CED5AP

Mandatory AP address:
 : : : : :

Send Long Preamble Headers

The Wireless LAN adapter can function in several different operating modes. Select the operating mode and enter the ESSID for your operating mode.

Cancel

Mobile Unit | Power | Encryption | WLAN A | ◀ ▶

Figure 8-17. Mobile Unit Property Page

The **Mobile Unit** page in the **Advanced Properties** window configures the terminal's operating mode and ESS ID. Selecting an operating mode in NICTT disables the operating mode selected in NCPA.

Use the **Operating Mode** pull-down menu to select one of the following operating modes for the terminal:

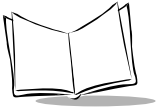

- **ESS (802.11 Station)** allows the terminal to transmit and receive data with an access point. The data rate is based on the number of transmit retries. This is the default.
- **IBSS (802.11 Ad Hoc)** enables terminals to form their own local network where they can communicate peer-to-peer without access points. Use IBSS to create networks within established cells. Terminals take turns generating beacons and handling probe responses. The terminal starting the IBSS network (i.e., the first terminal transmitting a beacon) determines the channel number and data rate used within the network.
- Select **Pseudo IBSS (Proprietary Ad Hoc)** for the highest throughput in an IBSS network for terminal testing. Pseudo IBSS does not support PSP terminals and does not use beacons or authentication. Each terminal must be on the same channel. If you select this option, the **Signal** and **Peers** tabs are no longer available. Pseudo IBSS is not recommended as a normal operational mode or for terminals operating on battery power.

Enter a 32-character (maximum) case-sensitive string NIC ESS ID (802.11 Extended Service Set Identifier) in the **ESSID** field to identify the wireless network. The ESS ID assigned must match the ESS ID of the access point. This value can also be set during Easy Installation.

The **Mandatory AP address** is the IEEE MAC address of the access point (AP) where the adapter associates. The adapter only associates to this access point when communicating on the network.

Power Properties

Select the **Power** tab in the Advanced Properties window to display the Power Settings property page. Use the Power property page to control terminal power consumption.

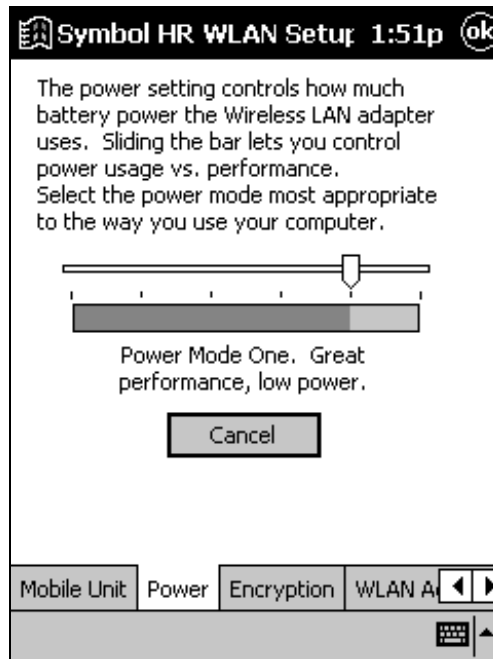
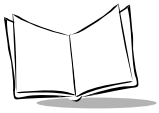

Figure 8-18. Power Property Page

There are two power consumption modes: Continuous Access Mode and Power Save Poll mode. CAM yields the best performance but uses the most power. CAM is the preferred mode for systems running on AC power. PSP saves significant amounts of power over CAM. PSP is the preferred mode for systems running on battery power.

Set the slider to the far right to retain CAM or set the slider to a PSP performance index (1 to 5). Each mode is described underneath the sliding scale.

Note: You must disable the Power Management capabilities in NICTT to use the settings in the NCPA Power property page.



Encryption

Select the **Encryption** tab in the Advanced Properties window to view the Encryption property page.

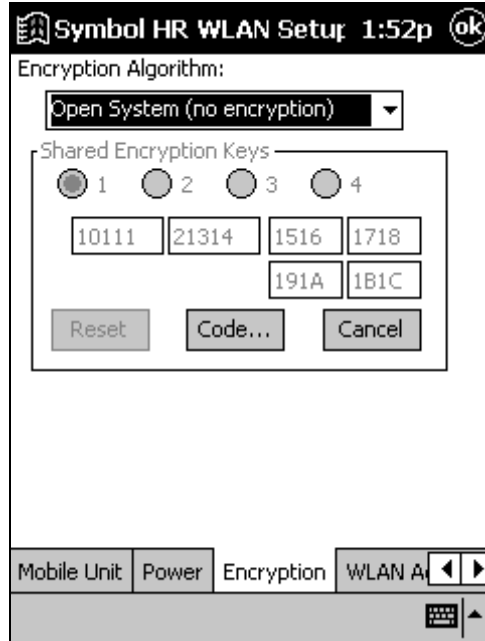

Figure 8-19. Encryption Property Page

Encryption is an efficient method of preventing data theft and improving data security in a wireless environment. Use the Encryption property page to configure WLAN adapter data packet Encryption settings.

Choose one of the following Encryption options from the **Encryption Algorithm** pull-down menu:

- Use the **Open Systems** option as a default setting when no data packet Encryption is needed over the network. Selecting Open Systems provides no security for the data being transmitted over the network. Select **OK** to enable Open System Encryption.
- Select **40-bit Encryption** and enter a 10 Hex digit password by spreading the 10 Hex digits between the two password fields provided for each Encryption key. Select **OK** to save and implement the password for the Encryption keys.

- **128-bit Encryption** is subject to export restrictions. An access code is required if 128-bit Encryption is selected and an export restrictions dialog box displays. Contact Symbol Technologies at 1-800-653-5350 for information on acquiring an access code.

If an access code is required, select the **Access Code** button to display the **Enable 128-bit Encryption** dialog box. Enter the access code in the 3 fields and select **OK**. The Access Code button disappears and the access code is stored.

Once 128-bit Encryption is enabled, select 128-bit Encryption from the Encryption Algorithm pull-down menu and enter a 26 Hex digit password by spreading the 26 Hex digits across the six password fields provided for each Encryption key. The 128-bit Encryption option provides the highest level of security. Select **OK** to save and implement the password for the Encryption keys.

WLAN Adapter Settings

Select the **WLAN Adapter** tab within the Advanced Properties window to view the WLAN Adapter property page. Use this page to configure hardware and radio settings and set an optional password for user access to the four advanced property pages.

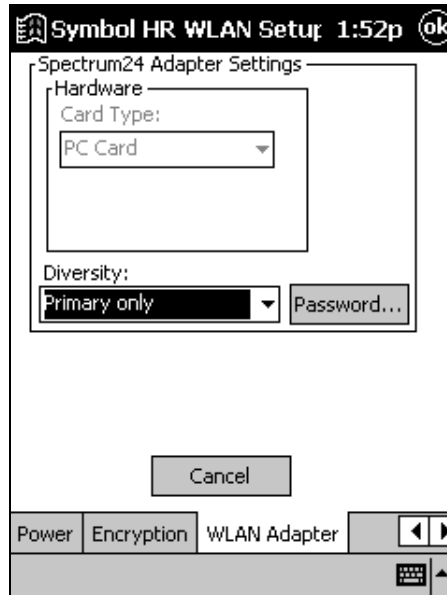
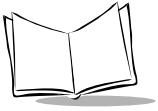

Figure 8-20. WLAN Adapter Property Page



To create a password, select the **Password** button. Enter a case-sensitive password (10 characters maximum) in the password field and select **OK**. This enables the Advanced property pages password dialog box which appears when Advanced is selected from the Easy Setup window.

To disable the password dialog box, enter the current password and leave the two new passwords fields blank. Select **OK**. To change the password, enter the current password and type a new password in the two new password fields. Select **OK**.

Select **Secondary Antenna** in the **Diversity** drop-down menu if you have a dual antenna on your WLAN adapter card. This can improve communication in highly reflective environments. Select **Primary only** if you do not have a dual antenna WLAN adapter card or a secondary antenna. Using diversity without dual antennas can cause poor wireless network performance.



Chapter 9

Wireless Wide Area Network Configuration

Introduction

Before a terminal can be used on a CDPD/GSM wireless network, you must select a provider and establish a service plan, and the terminal must be properly configured.

Configuring a CDPD WAN Connection (PPT 2733)

Before the SPT 2733 terminal can be used, you must get an account with an internet service provider.

All CDPD identification and address information is entered through the Preferences application on the PPT 2733 terminal.

To configure your PPT 2733 terminal for use on a CDPD network, tap Configuration Wizard on the Modem menu in Modem Manager.

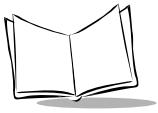

Configuration Wizard

The first time the Modem Manager software is started, or when Configuration Wizard is selected from the Modem menu within Modem Manager, the Configuration Wizard prompts you through the steps to configure and set up the terminal for operation.

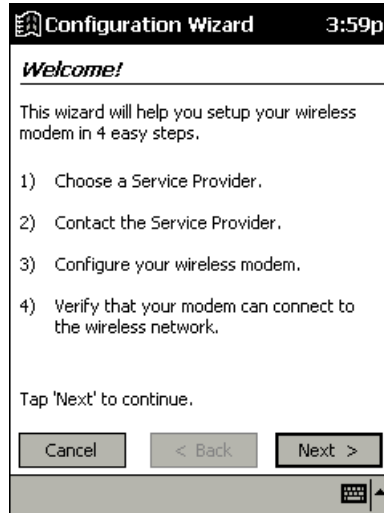

Figure 9-1. Configuration Wizard Welcome Screen

At any time, you can choose to cancel the Configuration Wizard by tapping **Cancel**. If you do choose to cancel, the Configuration Wizard appears the next time the Modem Manager is selected. It is recommended that once you begin the setup process you continue until it is completed.

1. To begin configuration, tap **Next**. The *Choose Service Provider* screen displays.

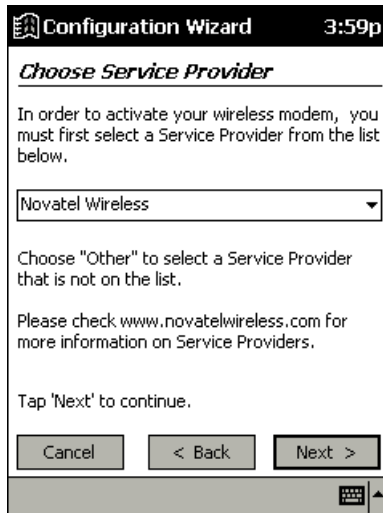
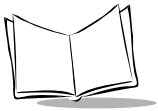

Figure 9-2. Choose Service Provider Screen

2. Select a Wireless Provider from the drop-down menu, and tap **Next**. The Contact Service Provider screen displays:



Figure 9-3. Contact Service Provider Screen



This screen tells you to note the modem Equipment ID number shown. Tap **Next** to continue.

3. The *Enter Modem Settings* screen displays:

The screenshot shows a mobile application interface titled "Configuration Wizard" with a time of 4:00p. The main heading is "Enter Modem Settings". Below the heading, there is a prompt: "Please enter the information given to you by your service provider." The form contains four input fields: "IP Address" with the value "192.0.0.1", "Primary DNS" with "0.0.0.0", "Secondary DNS" with "0.0.0.0", and "SPI" with "0". Below the fields, there is a note: "Tap 'Next' once you have entered this information." At the bottom, there are three buttons: "Cancel", "< Back", and "Next >". A keyboard icon is visible in the bottom right corner of the screen.

Figure 9-4. Enter Modem Settings Screen

4. Enter the required information and tap **Next** to continue. You are prompted to confirm the settings. Verify the information you entered is accurate and tap **Next**. The *Modem Configured* screen displays.

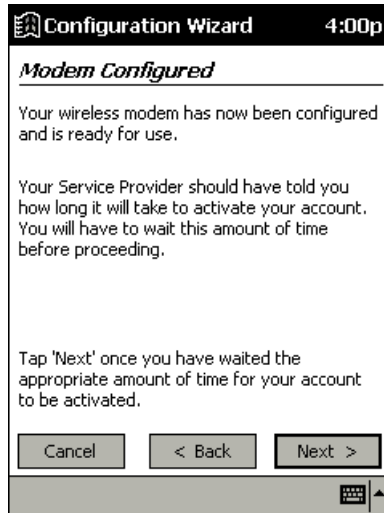

Figure 9-5. Modem Configured Screen

5. After you have waited the appropriate amount of time indicated by your service provider, tap **Next**. The *Checking Network* screen tells you to wait for your modem to register with the network.

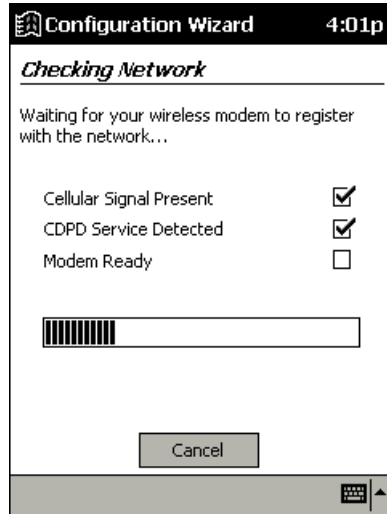
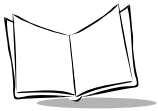

Figure 9-6. Checking Network Screen

6. A screen displays indicating that the modem successfully connected.

Note: *The Configuration Wizard does not proceed until a CDPD carrier selection is made.*

Maintenance Screens and Menus

The PPT 2733 terminal includes menu commands to make it fast and easy to configure and check the status of your modem. This section explains the menu commands specific to the Modem Manager.

Status Screen

The **Status** tab of the Modem Manager displays modem parameters. The modem's status is updated every 3 seconds.

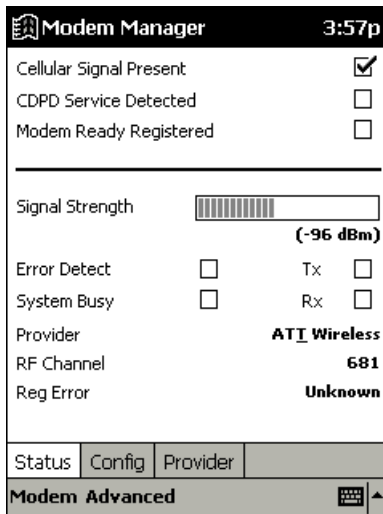
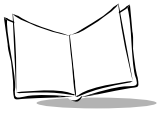

Figure 9-7. Modem Manager Status Screen

The following information is available from this screen:

Setting	Description
Cellular Signal Present	When checked, it indicates that the modem has identified a cellular signal.
CDPD Service Detected	When checked, it indicates that the modem has identified and is synchronized to a CDPD signal in the area.



Setting	Description
Modem Ready Registered	When checked, it indicates that the modem has successfully registered with a CDPD service provider in the coverage area. A working data connection exists and can be used by other applications to transmit and receive data. Until this checkbox is selected, the modem can neither transmit nor receive data.
Signal Strength	Measures Received Signal Strength from the wireless base station. These values range from one to ten bars. The greater the number of bars, the better the performance of the modem.
Error Detect	When checked, it indicates that a large number of errors have been detected by the modem. The modem may continue to operate but with a severely reduced performance, caused by the increased likelihood of connection retries and data errors when communicating with the wireless base station.
System Busy	When checked, it indicates that the currently detected CDPD system is busy. The modem may continue to operate but at a decreased level of performance.
Provider	Displays the CDPD channel's System Provider's Identifier.
RF Channel	Shows the CDPD channel currently active. If the terminal is not registered or is searching for a channel, the value displayed is either "Searching A" or "Searching B", depending on the state of the modem. Once a channel is detected, a numeric value for the channel displays.
Reg Error	This shows either "None" or a numeric value between 1 and 7. "None" indicates a successful registration without any errors. If a numeric error code is displayed, an error has occurred. Tap the button to display details about the error.

Configuration Screen

The screenshot shows the Modem Manager configuration interface. At the top, there is a status bar with the text 'Modem Manager' on the left and '3:58p' on the right. Below this, there are six configuration fields, each with a label on the left and a text input field on the right:

- IP Address:** 192 . 0 . 0 . 1
- Primary DNS:** 0 . 0 . 0 . 0
- Secondary DNS:** 0 . 0 . 0 . 0
- Side Preference:** B Preferred (with a dropdown arrow)
- Sleep Mode:** Enabled (with a dropdown arrow)
- Auto Power-Off:** Disabled (with a dropdown arrow)

At the bottom of the screen, there is a navigation bar with three tabs: 'Status', 'Config', and 'Provider'. The 'Config' tab is currently selected. Below the navigation bar, there is a section titled 'Modem Advanced' with a keyboard icon and a right-pointing arrow.

Figure 9-8. Modem Manager Configuration Screen

On the **Config** tab, you can edit configuration settings. The following settings are available:

Setting	Description
IP Address	This is the current IP address of the modem. Tap to enter a new IP address.
Primary DNS	This is the current Primary DNS address of the modem. Tap to enter a new DNS address.
Secondary DNS	This is the current Secondary DNS address of the modem. Tap to enter a new DNS address.
Side Preference	Configure the side preferences for the modem. All CDPD systems are categorized into "A" systems or "B" systems. This setting determines how the modem searches for a CDPD system among the two system category choices. See Side Preference Drop-Down on page 9-10.
Sleep Mode	Allows or disallows the modem to enter the low-power mode. This feature only functions on Wireless IP networks that support it. See Sleep Mode Drop-Down on page 9-10 for detailed information.

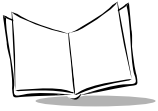

Setting	Description
Auto Power-Off	When enabled, this shuts off the modem when the session is disconnected.

Side Preference Drop-Down

Setting	Description
A only	The modem searches for a CDPD system on the "A" side only. For users who do not roam, this selection can sometimes speed the registration process, as the modem does not have to look on the "B" side as well before it can register.
B only	Same as "A only" except on the "B" side.
A Preferred	The modem searches for a CDPD system on the "A" side first and attempt registration on any system it finds. However, if the modem cannot register on the "A" side, it then attempts to find service on the "B" side. For users who roam, this setting would be appropriate if the home system was on the "A" side.
B Preferred	The modem searches for a CDPD system on the "B" side first and attempt registration on any system it finds. However, if the modem cannot register on the "B" side, it attempts to find service on the "A" side. For users who roam, this setting would be appropriate if the home system was on the "B" side.

Sleep Mode Drop-Down

Setting	Description
Enabled	The modem attempts to enter a low-power mode if it is not required to carry out any communications with a Network. The modem may respond sluggishly to the first communication request when it is required again.
Disabled	The modem is not allowed to enter sleep mode.

Provider Screen

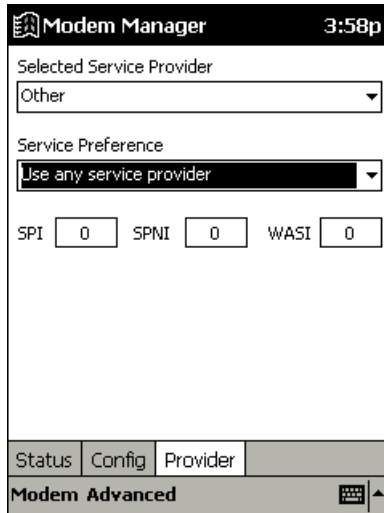
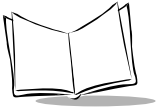

Figure 9-9. Modem Manager Provider Screen

On the **Provider** tab, you can modify provider settings. The following settings are available.

Setting	Description
Selected Service Provider	Selects the CDPD channel's System Provider's Identifier.
Service Preference	Configures the preferences for the service ID parameters. Refer to Service ID Preferences on page 9-12 for detailed information.
Service ID Parameters	Configures all identification values for a particular system or Wireless IP network: SPI is the current CDPD Base Station Service Provider Identifier. SPNI is the current CDPD Base Station Service Provider Network Identifier. WASI is the current CDPD Base Station Wide Area Service Identifier.



Service ID Preferences

Setting	Description
Only use selected service provider	The modem attempts to detect <i>only</i> the system in the Service ID parameters for registration. This is useful when you want to prevent roaming to any other system but your home system.
Prefer to use selected service provider	The modem first attempts to register on the system described by the SPI/WASI/SPNI entries. If no system is found, the modem attempts to register on the remaining available systems in the area. This is useful when you spend most time in one area and occasionally roam, or in cases where you have two systems but prefer service on one due to, for example, rate advantages. In these cases, enter the Network ID parameters that reflect the system you most often will register on.
Don't use selected service provider	The modem attempts to register on any system but that reflected in the Network ID entries. This is useful if you want to block registration on systems in your area that you do not have an agreement with. This may speed up the registration process in some areas.
Use any service provider	The SPI/WASI/SPNI entries are ignored. This is the default configuration and ensures that the modem attempts to register on any valid system that it can find.

Modem Menu

Tap **Modem** to display the *Modem Menu*. Options are described below.

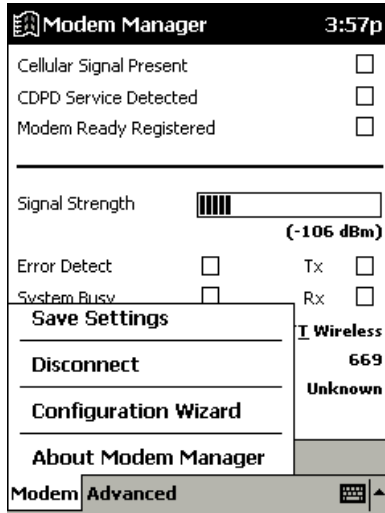
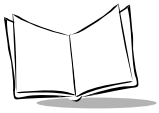

Figure 9-10. Modem Menu

Setting	Description
Save Settings	Saves any settings made in the Modem Manager Configuration and Provider screens.
Disconnect	Terminates the active Network session with the modem. If you have configured the AutoOff preference to turn the modem off when the session is disconnected, the modem may also power down. If disconnected, the Modem Manager can no longer perform 3-second updates.
Configuration Wizard	Launches the Configuration Wizard to configure your modem.



Advanced Menu

Tap **Advanced** to display the *Advanced Menu*. Options are described below

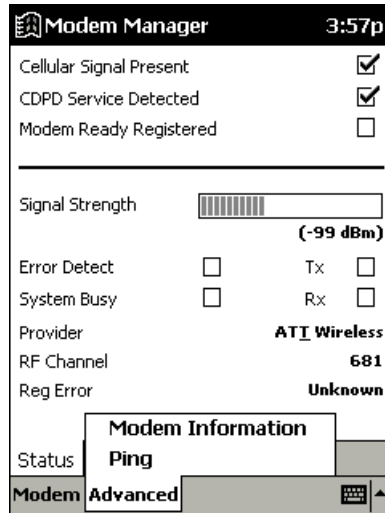

Figure 9-11. Advanced Menu

Modem Information

Tap **Modem Information** to view the modem manufacturer, equipment ID and model, and firmware version.

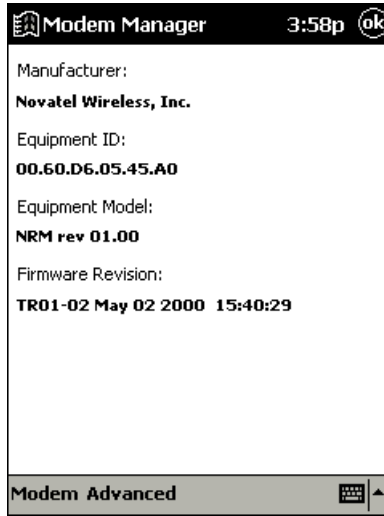
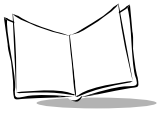

Figure 9-12. Modem Information Screen



Ping Screen

Tap **Ping** to send a packet to a particular IP address to determine if it is online. From this screen you can send a PING request to another network device whose network address you already know. This is useful to verify network connectivity.

Modem Manager 3:58p OK

Please enter the IP address and size of the PING message that you wish to send. The size of the PING message must be less than 100 bytes. Press Send when all information is entered.

IP Address 1 . 0 . 0 . 0

Size 4

Send

Modem Advanced

Figure 9-13. Ping Screen

As with other PING applications, enter the IP address of the other network device in the IP field, then select the desired payload size. Tapping *Send* sends the PING. A status line displays a "Success" or "Fail" message to indicate whether or not the PING was successful. There is a 20 second timeout for a response before a "Success" or "Fail" message may display.

There are some limitations on this PING implementation:

- The size of PING payload is limited to 99 bytes. If a payload of greater than that is entered, a data error message will be displayed.
- The delay to wait for response is fixed at 20 seconds.

Tap **OK** to return to the Modem Manager screen.

Help

Select **Help** from the **Start** menu for more information on Modem Manager.

Configuring a GSM WAN Connection (PPT 2734)

To set up a new connection configuration:

1. Tap **Settings** from the **Start** menu.
2. Tap the **Connections** tab, and select **Modem** to display the *Modem Connections* screen.

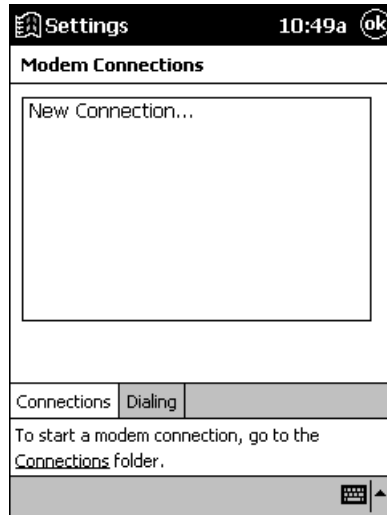
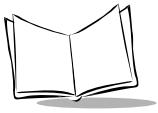

Figure 9-14. Modem Connections Screen



3. Tap **New Connection**. The *Make New Connection* screen displays.



Figure 9-15. Make New Connection Screen

4. Enter a name for your connection, then select **UbiNetics-GSM_PC_Card** from the drop-down menu.

- Your modem settings and TCP/IP address should be set automatically, but if you need to set them manually, tap the **Advanced** button and enter the information in the **Port Settings**, **TCP/IP**, and **Name Servers** tabs.

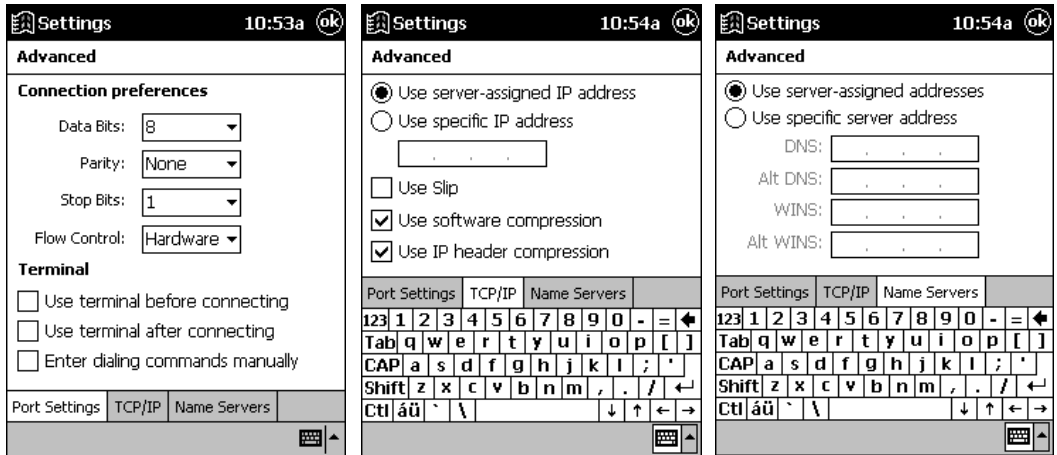

Figure 9-16. Advanced Settings

- When you have completed entering your settings, tap **OK**, then select **Next** from the *Make New Connection* screen.

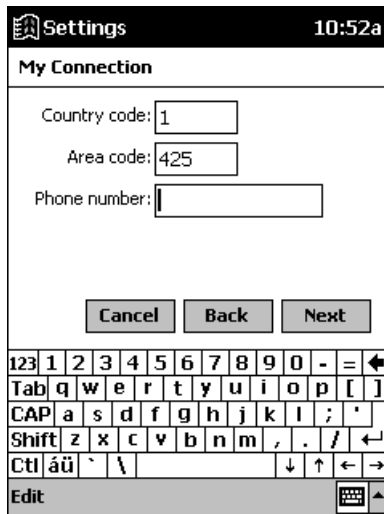
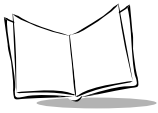

Figure 9-17. Advanced Settings



7. Enter the phone number, and tap **Next**.
8. Set the dialing settings on the next screen, and tap **Finish**. Your new connection is created.

Connecting via GSM

To connect using the GSM WAN connection you created:

1. Select **Programs** from the **Start** menu.
2. Tap the **Connections** icon.
3. Select the connection you created..

Connect To 7:58a

My Connection

User name:

Password:

Domain:

Save password

Phone: T9,7382424

Dial from: Work

Cancel Connect Dialing Options...

123 1 2 3 4 5 6 7 8 9 0 - = <

Tab q w e r t y u i o p []

CAP a s d f g h j k l ; ' <

Shift z x c v b n m , . / <

Ctl á ü ` \ < > < >

Edit

Figure 9-18. Personalizing your Connection

4. Enter a user name, password and domain. Also select if you are dialing from Work or Home, and check the **Save Password** box if you'd like the terminal to remember your password next time.

5. If you'd like to edit any dialing selections, tap **Dialing Options**.

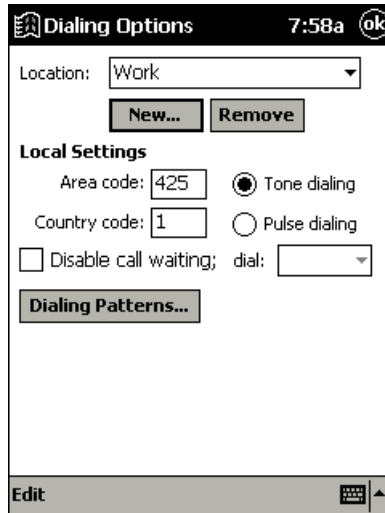
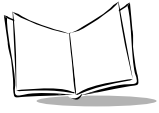

Figure 9-19. Dialing Options

6. Tap **Dialing Patterns** to edit country code, area code, or number dialing patterns.



Figure 9-20. Dialing Patterns



7. Tap **OK** until you return to your connection screen, and tap **Connect**. The terminal attempts to connect.

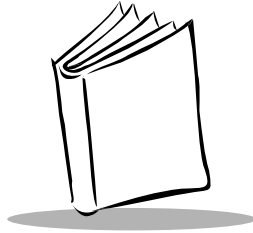

Chapter 10

Software Installation on Development PC

Introduction

To develop applications to run on the PPT 2700, the *Symbol Windows CE Software Developer's Kit (SDK)* is available. This SDK contains PPT 2700-specific software not available in the standard Microsoft Windows CE Platform SDK.

The minimum system configuration required to install the SDK is:

- IBM-compatible PC with Pentium 150 MHz processor or higher
- Windows®98 second edition, or Windows® NT operating system version 4.0 with Service Pack 5 or later, or Microsoft Windows 2000 operating system
- 24MB RAM for Windows 98, 32 MB RAM for Windows NT
- 100MB available hard disk space
- CD-ROM drive
- One available serial port
- Mouse.

Also, be sure the drive you are installing to accepts long filenames (larger than the 8.3 filename convention).

Before You Install the SDK

Before you install the Symbol Windows CE SDK, install the following tools:

- Microsoft eMbedded Visual Tools 3.0.
- Windows CE Platform SDK for Pocket PC.
- Microsoft ActiveSync.

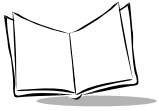

Symbol Windows CE SDK

The SDK installation program loads the required Windows CE components on the development PC used to create the image files (via Terminal Configuration Manager) for download to the terminal.

The Symbol SDK includes:

- Symbol-provided files
- Printer drivers
- TCM scripts
- Sample code
- This Product Reference Guide.

Installing the SDK on the Development PC

The Symbol SDK installs through Windows in the directory C:\SYMBOL WINDOWS CE SDK, and also installs files in the Windows CE Tools directory (generated by the CE Tool Kit).

Installing the SDK

Install the SDK from the Symbol website www.symbol.com. Follow the installation prompts.

Note: *To ensure the best operation of the SDK, do not change the base path set up in the installation.*

Once installation of the SDK is complete, use eMbedded Visual C++ or eMbedded Visual Basic to view the active Windows CE configuration, Microsoft Pocket PC, and display the directory in which the SDK is installed.

Installing Other Development Software

Developing applications for the PPT 2700 may require installing other development software such as application development environments on the development PC. Follow the installation instructions provided with this software.

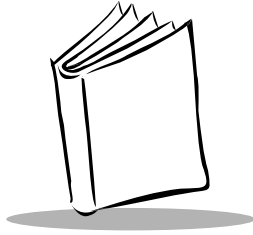

Chapter 11

Configuring the Terminal

Introduction

This chapter describes the Terminal Configuration Manager (TCM), and how it is used to specify and load files into the flash memory of the PPT 2700 using the terminal's Initial Program Loader (IPL).

In TCM, you create a *script* that contains the information (commands to copy files) for building the image. TCM works with directory windows which display the directory structure of your script and the source directories, files, and scripts from which you pull components. You can open multiple scripts, drag and drop items from a drive/directory to the script, rename and delete files in the script, etc. Upon building the image, TCM adds all the files, directories, and scripts referenced in the script to the image.

The SDK includes a number of standard scripts and demos/samples for you to use as a base for creating your own scripts. These scripts can be found in the SYMSDK\SCRIPTS directory.

Note: *Before you create a script to build a hex image, identify the files required (system files, drivers, applications, etc.) and locate the files' source directories to make the script building process easier.*

The required processes for building a hex image in TCM include:

- Starting TCM
- Creating or modifying a script

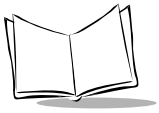

- Building the hex image
- Sending the hex image.





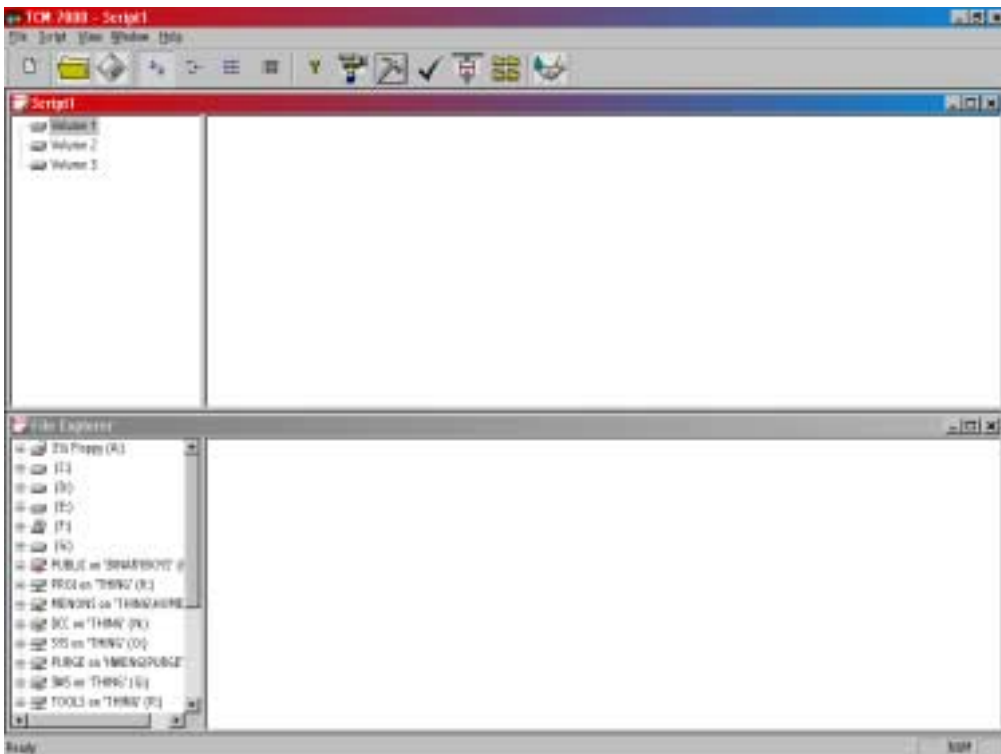



Starting Terminal Configuration Manager

To start TCM, double click on the TCM icon in the SYMSDK group. The following screen appears, displaying two directory windows; Script1 and File Explorer. Each directory window is split; the left half (or *pane*) of the window displays the directory tree for the current drive, and the right half displays the directory contents for the current drive.



The following table lists the components of the TCM start-up screen.

Table 11-1. TCM Screen Components

Component	Description			
Script Window	<p>Associated with a script file containing the information to create a Flash Disk image. This window is the <i>target</i> window, or the primary TCM window in which you can create a script or change a script file's contents by copying, deleting, and renaming files and directories. More than one script window can be open at a time.</p> <p>The Script Window consists of two panes, the Directory Tree Pane on the left and the Directory Contents Pane on the right. Subordinate directories and files of each volume are listed in the Directory Contents Pane.</p>			
File Explorer	A <i>read-only source</i> window for files and/or directories to include in the script being built.			
Tool Bar	Contains the tools, illustrated below, for taking action on a script.			
		Create a new script file.		Check script for existing files.
		Open a script file.		Select the hex image to load.
		Save a script file.		Tile windows.
		View script properties.		Build and send the hex image to the terminal.
		Build a script.		

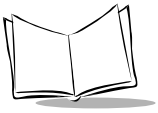

Defining Script Properties

Before a script is created, the script properties must be defined. This defines the type of terminal, type of flash type, number of disks being created, and the memory configuration of each disk volume.

To define the script properties:

1. With TCM open, click on the Script Window to make it the active window.
2. Under the script menu, select the Properties option.

OR

Click on  from the tool bar. The Script Properties window displays.

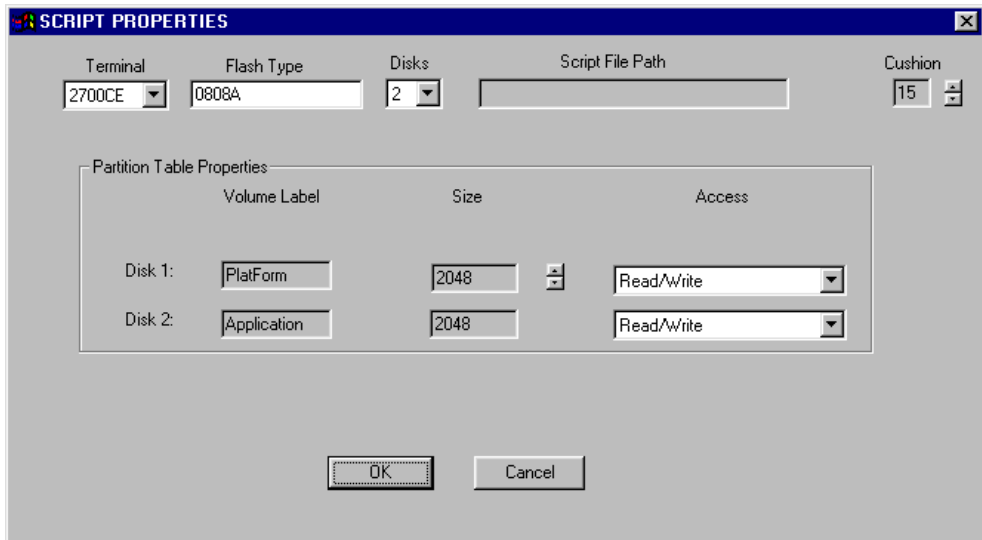

	Terminal	Flash Type	Disks	Script File Path	Cushion
	2700CE	0808A	2		15

Partition Table Properties			
	Volume Label	Size	Access
Disk 1:	PlatForm	2048	Read/Write
Disk 2:	Application	2048	Read/Write

3. Under the Terminal pull-down menu, select 2700CE.
4. In the Flash Type field, select 0808A Flash Type.
5. Under the Disks pull-down menu, select the number of disk volumes to be created.

Note: *The options available under the disks pull-down menu changes depending on the flash type. Some flash types only have one option for the number of disk volumes, others have two options.*

6. If you have selected three volumes under the disk pull-down menu, you have the option to change the memory configuration of the second and third volumes. To do so, click on the up or down arrow for either of the volumes, until the memory configuration of each is set to the desired value. You will notice that as you change the values for one of the volumes, the other volume is automatically changed accordingly.
7. For each disk volume, determine the Read/Write access option.
8. The Script File Path displays the path of the selected script file.
9. Select a Cushion percentage from the Cushion pull-down menu to specify the percent of flash reserved for cushion. Choosing a higher number reduces disk storage space, but also increases write performance on fragmented disks or disks becoming full. To speed the writing process, select as high a number as your storage needs permit (up to 25%).

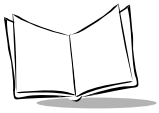

Creating the Script for the Hex Image

On start-up, TCM displays the screen shown on page 11-2, with the Script1 window and File Explorer window pointing to the SYMSDK\SCRIPTS directory and the SDK7X00 directory. The Script1 Window directory pane displays three volumes: Volume1, Volume2, and Volume3. Depending on the type of flash chip you have, the number of volumes may change. Files can be added to each of the volumes.

- Create a new script file or open an existing script
- Drag and drop existing files and directories to that script
- Set the script parameters
- Save the script
- Review and modify the script.

Each process is described in the sections that follow.

Open a New or Existing Script

Scripts are created in the Script Window.

To open a new script:

- Choose New from the File Menu, OR
- Click on  from the tool bar.

To open an existing script (e.g., a standard script provided in the SDK):

- Choose Open from the File Menu and select the script file name, OR
- Click on  from the toolbar and select the script file name, OR
- Double click on an existing script in the Script Browser window.

Note: *If you open and make changes to an existing script, saving the changes writes over the existing script. If you wish to use an original or Symbol-supplied standard script as a base and save the changes in a new script, use Save As instead of Save after making the changes.*

Copy Components to the Script

Copy *files or directories* to the script being generated:

1. Click on the File Explorer Window to make it the active window.
2. Click on the source directory in the Directory Tree Pane. TCM displays the directory contents in the Contents Pane.
3. Click on the file(s) and/or directory in File Explorer.

Note: *Optionally, use the standard Windows Shift+Left-click and Control+Left-click features to select multiple files and directories.*

4. Drag and drop the selected file(s) and/or directory from File Explorer to the target directory in the Script Window.

OR

Click on the target directory and select the File Explorer Copy icon from the toolbar.

Save the Script

To save the changes to a new script:

1. From the File menu, choose Save As.

OR

On the toolbar, click on  .

2. Enter the path and filename. TCM appends a .TCM extension to the script.
3. Choose the OK button.

Note: *If you save an untitled script, TCM by default saves the script to the directory that the Script Browser is pointing to.*

To save changes to an existing script:

- From the File menu, choose Save, OR

- On the toolbar, click  .

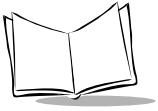

Note: *If you open and make changes to an existing script, saving the changes writes over the existing script.*

If you wish to use an original or Symbol-supplied standard script as a base and save the changes in a new script, use Save As instead of Save after making the changes.

Building the Image

As part of the build, TCM performs a check on the script which verifies that all files referenced in the script exist. If the image is bootable, TCM verifies that the boot files are available.

Note: *Performing a check is more important for previously existing scripts to ensure that files referenced in the script are still in the designated locations.*

To check a script:

1. In the Script Window, select the script.
2. Save the script, if not already saved.
3. From the Script Menu, choose Check.

OR

On the toolbar, choose  .

4. TCM verifies that files referenced in the script exist on available drives and lists an error message in the Errors found box for any missing files.
5. Choose the OK button to exit.

To build a script:

1. In the Script Window, select the script to be built.
2. From the Script menu, select Build.

OR

On the toolbar, choose . The Configure Build window appears.

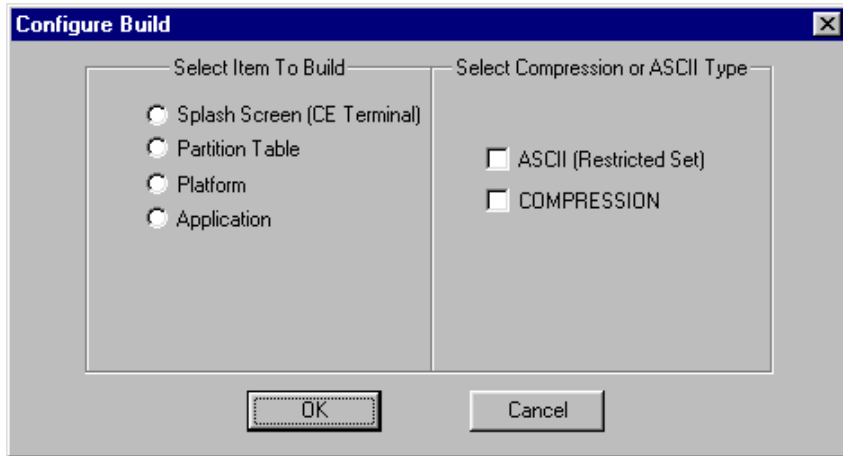

3. Select whether to build the partition table, or one volume.
4. Select ASCII format for your hex image, or Compression, which reduces the size of most hex images in order to speed downloading. Click OK.
5. TCM performs a check. If the script is has no errors, TCM proceeds with the build.

If the Build Fails

If the build fails, TCM displays a message indicating which file(s) are missing.

If the total amount of flash required by the script exceeds the image size, a TCM error results. To correct this, reduce the number of files in the volume, or make the disk non-bootable. Refer to [Defining Script Properties](#) on page 11-4 for more information on setting the image size appropriately.

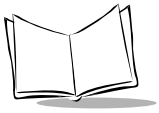

Sending the Hex Image

Once the hex file is built, you are ready to download it to the terminal. A Hex image download requires both TCM and a program loader stored on the terminal. The terminal comes with a program loading utility, Initial Program Loader (IPL), stored in the terminal's write-protected flash. To run IPL, the terminal must be inserted in a cradle or connected to a host PC by direct serial connection.

Saving the Script

If you made changes to the script since last saving it, save the script again.

Connect The Terminal and Development PC

To send the hex file to the terminal, first link the terminal and development PC by one of the following devices:

- Direct serial link
- Cradle (refer to [Chapter 1, Getting Started](#) for more information on setting up the cradle).

Begin the Send in TCM

In TCM on the PC:

1. Select the script.
2. From the file menu, choose Load Terminal.

OR

On the toolbar, choose  . The Load Terminal screen displays.

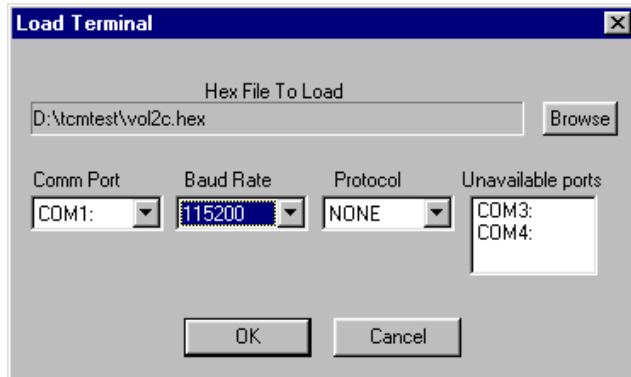

3. If the correct hex file is not displayed in the Hex File to Load field, click on the browse button and navigate to the correct hex file to be downloaded.
4. Click on the Comm Port pull-down menu and select the COM port being used. Ports already in use display in the Unavailable Ports field.
5. Click on the Baud Rate pull-down menu and select the appropriate baud rate. Your options are 2400, 4800, 9600, 19200,38400, 57600, 115200.
6. On the Protocol pull-down menu, select None.

Setting Up IPL to Receive the File

To set up IPL on the terminal to receive the files being downloaded via TCM:

1. Cold boot the terminal by pressing the reset button inside the battery compartment while holding down the Function button.
2. Press and hold the App1 and App4 buttons. While holding down these buttons, press and hold the battery door switch inside the battery compartment (on the left). This all must occur within 3 seconds after resetting the terminal.

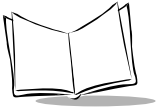

3. Continue to hold these buttons, including the battery door switch, until the IPL Baud Rate menu displays:

```
IPL VER X.XX
IPL Key Sequence

-> 115,200
    57,600
    38,400
    19,200
    9600
    Auto Baud

Press Up/Down to
select Baud Rate

Action to Continue
```

If necessary, adjust the contrast by holding down the Function button and pressing the up scroll button to darken the screen, or the down scroll button to lighten the screen.

4. The version number on the top of the screen identifies the version of IPL you are using. After the version number one of the following messages appears, indicating why IPL was invoked:
 - IPL Key Sequence: IPL key sequence was pressed.
 - Partition Table not found: indicates no partition table was found.
 - Partition Table Checksum Error: indicates a checksum error was detected in the partition table.

Use the up and down scroll buttons on the terminal to scroll to the appropriate baud rate, then press the Action button to accept the selected baud rate. If no selection is made within 10 seconds, the baud rate 115,200 is automatically selected.

5. IPL displays the Main Menu which lists the partitions/applications that can be downloaded.

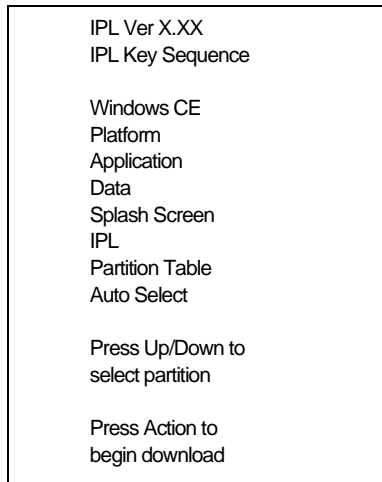

6. Use the up and down scroll buttons to select the partition to be received, then press the Action button, or select Auto Select to download several partitions in sequence.

Note: *Auto Select is the default, and will be selected if no other selection is made within 10 seconds.*

7. The following screen displays:

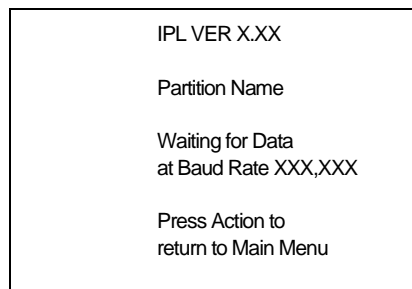

Partition Name reflects the selection made on the Main Menu, and *Baud Rate XXX,XXX* displays the selection chosen from the baud rate menu.

This screen continues to display until the first character of the image to be

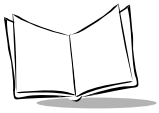

downloaded is received from the host. While this screen is displayed, pressing the Action button returns IPL to the Main Menu screen.

8. Insert the terminal in a cradle, or connect it to a host PC with a serial cable.
9. Return to the host PC, and press the OK button on the *Load Terminal* dialog box.
10. As soon as the first character of data is received, IPL displays the receiving screen:

IPL VER X.XX

Partition Name
Downloading Data

Processing XXXXX KB
of YYYYY KB image

Note: *If the Pre-erase Attribute bit is set on the partition being downloaded, the message “Pre-Erasing Flash” also appears.*

This screen indicates that the area selected in the Main Menu screen is currently downloading, and displays until an entire image is received, or until an error is detected. As more data is received, the Receiving Screen is updated to reflect the current status.

To process the data, IPL must receive, erase, and write the entire image. With the exception of the disk images, IPL receives the entire image before starting the erase, and completes the erase before starting to write. With disk images, IPL multiplexes all three operations as data is received.

11. When the entire image is received, IPL indicates that the download is complete.

IPL VER X.XX

Partition Name
Download Complete

Press Action to
return to Main Menu

Cold Boot Exits IPL

If Auto Select was selected on the Main Menu, the text “Auto Select Enabled” appears in place of “Cold Boot Exits IPL.”

12. If Auto Select was selected on the Main Menu, IPL immediately returns to the Waiting for Data Screen to wait for the next image. If any other selection was made on the Main Menu, IPL stays at the success screen until you press Action. Once the screen is acknowledged, IPL returns to the Main Menu to wait for a new selection.
13. When all partitions are downloaded successfully, cold boot the terminal by pressing the reset button inside the battery compartment while holding down the Function button.
14. Close TCM on the host PC by selecting Exit from the File Menu.

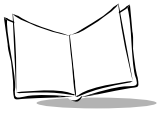

Error Messages

IPL Error Detection

While receiving data, IPL performs many checks on the data to ensure that the data is received correctly. If an error is detected, IPL immediately aborts the download, and reports the error on an error screen:

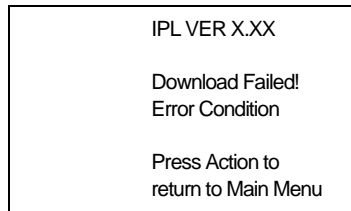

This screen displays until you press Action. Once the screen is acknowledged, IPL returns to the Main Menu screen to wait for a new selection.

The cause of the error displays under the Download Failed! indication. The errors that can be reported, and the probable cause of the error, are as follows:

- | | |
|------------------------------|---|
| Invalid Image | This error occurs if another record is received before the Header Record. Ensure the Header Record is the first record downloaded. |
| Partition Not Defined | The destination code is part of the Header record and is used as an index into the partition table. The partition table entry located at this index contains partition information for the data downloaded. If the AutoSelect option is selected, a check is made to ensure that valid partition information exists in the partition table at this index. The check verifies that the Area Name and Sector Size are both non-zero. If not, this error occurs. |
| Wrong Partition | If a specific partition is selected from the partition list, and the destination code of the Header record downloaded does not match the index of that partition, this error occurs. |
| Image Too Big | The size of the image is also part of the Header record. If the data to be written exceeds the size of the partition as indicated in the partition table, this error occurs. |

Invalid Image	This error occurs if another record is received before the Header Record. Ensure the Header Record is the first record downloaded.
Incorrect Byte Count	Image data is processed until the End Of File (EOF - Record Type 01) record is received. This error occurs if IPL detects that the number of bytes received does not equal the number of bytes sent.
Unable to Verify Partition Data	If the Receive and Verify bit is set for that partition, the data is verified, the flash sector erased, and the data written to the flash part. If this data can not be verified, this error occurs.
Transmission Errors	<p>The following error messages may appear if an error occurs during transmission:</p> <p>Checksum Error occurs if an invalid checksum is detected in the record.</p> <p>Invalid Record occurs if a record is not defined in the Symbol Hex File Format.</p> <p>Connection Lost occurs if one of the handshaking lines is de-asserted during download.</p> <p>Address Out of Sequence occurs if the address of the data received is not sequential.</p>

TCM Error Messages

TCM validates the cells in your partition table when the Execute button is pressed. Cells highlighted in red contain an error. Partition loading is disabled until all errors are corrected. Following are errors that TCM may encounter, and possible solutions.

Error - Partition Size	The size of a partition must be an integral multiple of the <code>FFSSectorSizeInBytes</code> specified by the .ini file. When the user enters a partition size, TCM rounds up to the next highest integral multiple of the sector size and displays this value in the partition table grid. This error check is made upon value entry, independent of the Execute button.
Error - Image Larger than Partition	If the required size of the binary image file is larger than the associated partition size, the Partition Size cell in the partition grid turns red to highlight the error. The Required Size cell indicates the actual size required.
Error - Total size of all FFS Partition	If the total memory allocated to the 3 FFS partitions is greater than the total Flash Memory on the terminal, the Used FFS Memory display box turns red. Decrease the size of one or more of the partitions, then recheck the configuration using the Execute button.

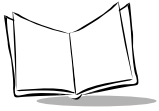

Error - Partition Size

The size of a partition must be an integral multiple of the `FFSSectorSizeInBytes` specified by the `.ini` file. When the user enters a partition size, TCM rounds up to the next highest integral multiple of the sector size and displays this value in the partition table grid. This error check is made upon value entry, independent of the Execute button.

**Error - Source/
Destination Path
Verification**

If the directory paths specified by the Source and Destination cells do not exist, the cell containing the non-existent path turns red to highlight the error.

Creating a Splash Screen

To generate a custom splash screen, use Microsoft Visual Studio, Microsoft Visual C++ version 6.0. Select Insert, Resource. Next, select Bitmap, New.

To create the screen:

1. Create a 4-color bitmap with dimensions of BX x BY where:
 - BX is less than or equal to 240 pixels
 - BY is less than or equal to 320 pixels
 - The bitmap is less than 240 by 320 pixels
 - 4 colors must be selected
 - The total bitmap size must be less than or equal to 16384 (16K).

Generally, the bitmap file size should be less than or equal to 16384 bytes (16K).

2. To change the bitmap properties, double-click on the bottom-right corner of the bitmap when the cursor appears as a double arrow. The Bitmap Properties dialog box displays.
3. Select Width (<240), Height (<320) and Colors (4).
4. Select 4 colors so that 2 bits are used for each pixel of data in the bitmap file.
5. Select a new file name.
6. Select Image from the toolbar. Select Flip Vertical to invert the image.

If other tools are used, be sure to create the bitmap with the size less than or equal to 16K and with 4 colors.

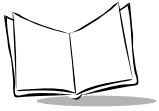

Loading the Splash Screen via TCM

To load the bitmap:

1. Click TCMMain.exe in the TCM directory.
2. Connect the PPT 2700 to the PC and invoke IPL to prepare the terminal to receive the splash screen download.
3. In the partition table, double-click on the Source column entry box for Splash Screen. The Specify Source dialog box appears. Select the bitmap file.
4. Double-click on the Destination column entry box for Splash Screen.
5. Select Create Image in the Hex Image file dialog box.
6. After the image is created, select Load.
7. Close TCM.

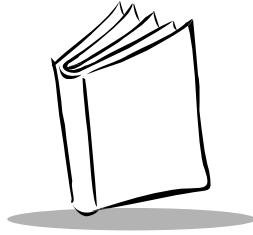

Chapter 12

Maintenance and Troubleshooting

Introduction

This chapter includes instructions on cleaning and storing your terminal, and provides troubleshooting solutions for potential problems during terminal operating.

Maintaining the PPT 2700

For trouble-free service, observe the following tips when using your PPT 2700:

- Take care not to scratch the screen of your PPT 2700. When working with your PPT 2700, use the supplied stylus or plastic-tipped pens intended for use with a touch-sensitive screen. Never use an actual pen or pencil or other sharp object on the surface of the PPT 2700 screen.
- Although your PPT 2700 is water and dust resistant, do not expose it to rain or moisture for an extended period of time. In general, treat your PPT 2700 as you would a pocket calculator or other small electronic instrument.
- The touch-sensitive screen of your PPT 2700 contains glass. Take care not to drop your PPT 2700 or subject it to strong impact.
- Protect your PPT 2700 from temperature extremes. Do not leave it on the dashboard of a car on a hot day, and keep it away from heat sources.
- Do not store or use your PPT 2700 in any location that is extremely dusty, damp or wet.

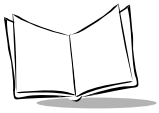

- Use a soft lens cloth to clean your PPT 2700. If the surface of the PPT 2700 screen becomes soiled, clean it with a soft cloth moistened with a diluted window-cleaning solution.

Troubleshooting

Table 12-1. Troubleshooting

Problem	Possible Solution
PPT 2700 terminal does not turn on.	Adjust the contrast control. Make sure batteries are installed properly. Replace the batteries. If your PPT 2700 terminal still does not operate, try a soft reset; see Resetting Your PPT 2700 Terminal on page 2-12.
PPT 2700 does not emit sound.	Check the System Volume slider in the Sounds & Reminders properties dialog box (under Start/Settings) to make sure the volume is not turned down.
PPT 2700 turns itself off.	Your PPT 2700 terminal is designed to turn itself off after a period of inactivity. This period can be set from one to five minutes, in one-minute intervals. Check the Power dialog box (in the System tab under Start/Settings), and change the setting if you need a longer delay before the automatic shutoff feature activates.
PPT 2700 stops responding to screen input.	Perform a soft reset. See Resetting Your PPT 2700 Terminal on page 2-12.
PPT 2700 responds inaccurately to stylus taps.	Align the screen. Choose Align Screen from the System tab under Start/Settings , or hold down the Function button and press the Action button.
PPT 2700 doesn't recognize my handwriting.	For your PPT 2700 to recognize handwriting input with the stylus, characters must be written a certain way. See Appendix A, Character Recognizer for information about how to write character strokes. Make the character strokes in the lower character entry area on the screen — not on the display part of the screen. Make sure you are writing lower-case letters in the left-hand side, numbers in the right-hand side, and upper-case letters in the center of the writing area.

Table 12-1. Troubleshooting (Continued)

Problem	Possible Solution
Tapping the screen buttons or icons does not activate the corresponding feature.	Align the screen. Choose Align Screen from the System tab under Start/Settings , or hold down the Function button and press the Action button.
A message appears stating that your PPT 2700 terminal memory is full.	Delete unused memos and records. If necessary, you can save these records on your computer. If you are copying files to your terminal, adjust the memory allocation. Select Start , then Settings , and select the System tab. Tap Memory and adjust the slider. Remove programs you no longer use. Select Start , then Settings , and select the System tab. Tap Remove Programs , select the unused program and tap Remove .
PPT 2700 is not communicating with the host PC.	Ensure the PPT 2700 is connected to the host PC via serial cable, or is placed in a cradle connected to the host PC. Confirm that the PPT 2700 and host PC are communicating at the same baud rate. Consult ActiveSync Help on your host PC.
Beamed data does not transmit.	Confirm that the PPT 2700 terminals are 5" apart, and that the path between the two devices is clear of obstacles. Adjust the room lighting or move to a different location.
When receiving beamed data an out of memory message appears.	Your PPT 2700 terminal requires at least twice the amount of memory available as the data you are receiving. For example, if you are receiving a 30K application, you must have at least 60K free.
Your PPT 2700 does not accept scan input.	Verify that the terminal is loaded with a scanning application. See your System Administrator. Check to be sure the bar code symbol is not defaced. Be sure you are within proper scanning range. Be sure the terminal is programmed to accept the type of bar code you are scanning. If you are expecting a beep on a good decode and don't hear one, check that the application is set to generate a beep on good decode. If the PPT 2700 stops emitting a laser beam when you press the trigger, check your battery level. When the battery is low, the scanner shuts off before the terminal notifies you of the low battery condition.

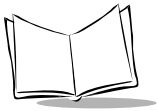
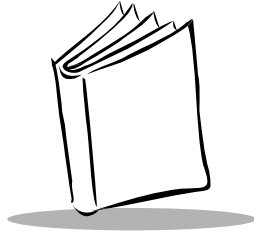

Table 12-1. Troubleshooting (Continued)

Problem	Possible Solution
Your PPT 2700 is not dialing out.	Remove the terminal from the cradle. The modem will not work if the terminal is actively connected to the desktop computer. Ensure the modem is connected to the terminal and the telephone jack. Ensure Hayes Compatible Modem on COM1 is selected. Select Start , then Settings , and select the Connections tab. Tap Modem , select your connection and tap Next twice. Make sure Wait for dial tone before dialing is selected.
Your PPT 2700 is dialing but not connecting.	Ensure the network you are calling supports Point-to-Point Protocol (PPP) Ask your networking administrator. Ensure the location is correct. Select Start , then Settings , and select the Connections tab. Tap Modem . On the Dialing tab, check Location . Tap Dialing Patterns to make sure the correct numbers are being dialed. Verify you are dialing the right number. Select Start , then Settings , and select the Connections tab. Tap Modem . Tap the connection, then Next and check the phone number. Disable call waiting. Select Start , then Settings , and select the Connections tab. Tap Modem . On the Dialing tab, select Disable call waiting , and enter the disable code obtained from your telephone company.

Note: *If, after performing these checks, the terminal is still not reading symbols, contact your distributor or Symbol Technologies.*



Appendix A

Character Recognizer

Using Character Recognizer, you can write characters directly on your terminal screen with your stylus. These characters are translated into typed text. Use Character Recognizer to enter text, for example, to write a note or to fill in fields in a dialog box.

The default writing mode for Character Recognizer is lowercase (Jot-compatible) mode. [Figure A-2 on page -3](#) provides examples of how to write characters in lowercase mode. To use uppercase (Graffiti-compatible) mode, tap **Uppercase Mode** in **Options** on the input method menu. Whether a letter appears in uppercase or lowercase when it is converted to typed text depends on where in the input panel you write it, not on the mode selected.

The Character Recognizer input panel is divided into three writing areas. Letters written in the left area (labeled ABC) creates uppercase letters, and letters written in the middle area

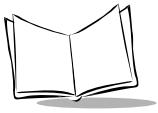

(labeled abc) creates lowercase letters. Use the right area (labeled 123) for writing numbers, symbols, special characters, and punctuation.

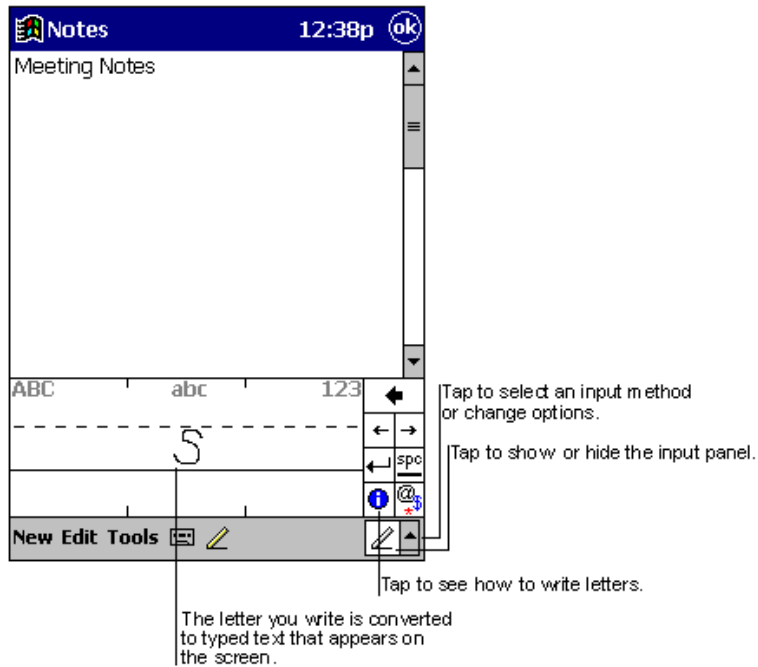

Figure A-1. Using Character Recognizer

The following chart illustrates some of the characters you can write in lowercase mode (the dot on each character is the starting point for writing). Note that although you write a letter in lowercase, the case of the text displayed depends on where you write the letter. For

example, if you write a lowercase "a" in the ABC area, an uppercase "A" displays on the screen.

Letter Area					Number/Punctuation Area														
A	a	a			N	n				0	0))				
B	b	b			O	o	o			1	1			+	+				
C	c				P	p	p			2	2	2		*	x	∞			
D	d	d			Q	q	q			3	3			/					
E	e				R	r	r			4	4	4	4	L	\				
F	f	f			S	s				5	5	5	5	?	?	?			
G	g	g			T	t	7	7	v	+	6	6			!	!			
H	h	h			U	u	u			7	7			@	@				
I	i	i			V	v				8	8			&	4				
J	j	j			W	w	w			9	9			‘	‘				
K	k	k	k	α	X	x	x			>	>			“	“				
L	l	l	l		Y	y	y			·	·			-	-				
M	m				Z	z				((

space	←
back space	→

enter	↵
back space	→

Figure A-2. Character Chart

For more information on using Character Recognizer and for demos of all characters, tap  on the Character Recognizer input panel.

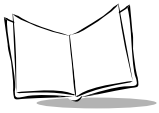

PPT 2700 Series Product Reference Guide

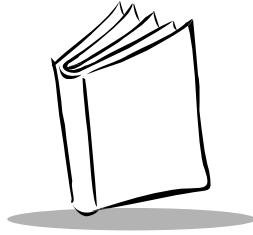

Appendix B

Demo Program

Introduction

A button-launch demo program illustrates how to use some of the terminal's many applications. If the demo program is not already on your PPT 2700 (check the Start menu), you may download the program from the *Symbol Windows CE Software Developer's Kit (SDK)*. See [Chapter 3, Customizing Your PPT 2700](#) for instructions on adding programs to your terminal.

The following options are available on the Button Launcher Task, and are described in this chapter.

- Setup: accesses the Control Panel, NICTT, and Diagnostics.
- Scanner: sample scanning application.
- File Explorer: File management utility.
- MSR Sample: sample Magstripe reader application.
- CE Apps: accesses standard Windows CE applications.

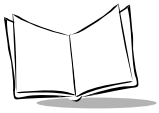

To initiate the demo program, select **PPT 2700 Demo** from the **Start** menu. The initial demo program dialog box appears.

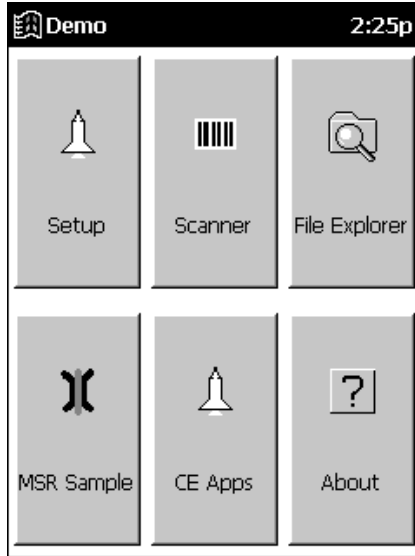

Figure B-1. Main Dialog Box

Setup

Select the **Setup** button to display the following dialog box:

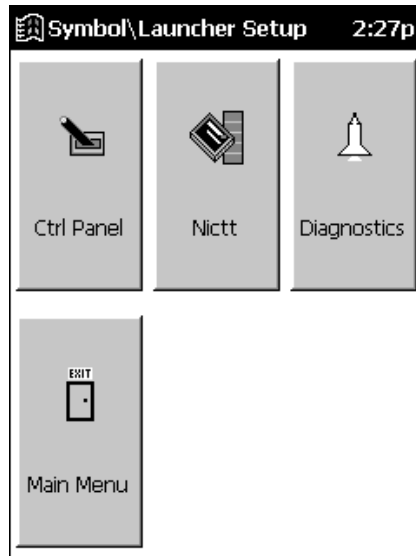
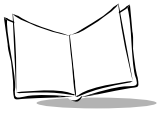

Figure B-2. Symbol Setup Dialog Box

Control Panel

Select **CtrlPanel** to display the *Control Panel Test Program* dialog box. This dialog box provides a convenient way to view and set terminal settings, such as scanner parameters,



display settings, audio settings, printer settings, setting date and time, and aligning the touch screen. It also serves as a sample code on many of the Symbol-specific CAPI calls.

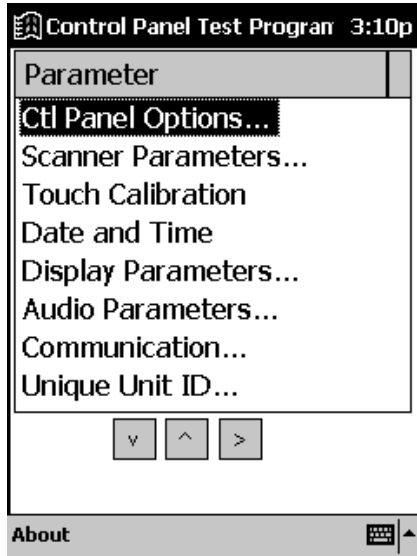

Figure B-3. Control Panel Test Program Dialog Box

NICTT

For information on NICTT, the Spectrum24 configurator, see [Chapter 8, Spectrum24 Network Configuration](#).

Diagnostics

Select **Diagnostics** to display the following dialog box:

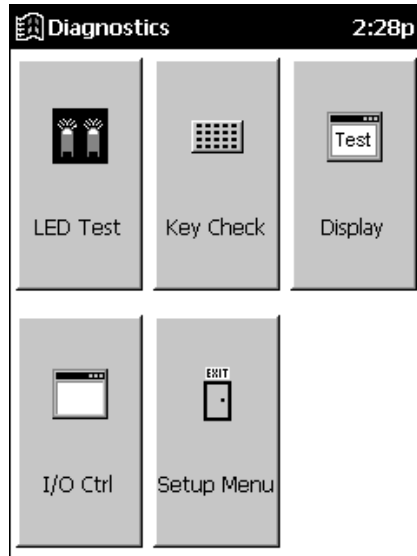

Figure B-4. Diagnostics Dialog Box

This dialog box provides testing to ensure various aspects of the terminal are functioning correctly. The following options are available:

- LED Test tests the green decode LED-on and LED cycle to ensure it is functioning properly. This option also allows you to view the state of the LED (on or off).
- Key Check identifies each button on the terminal (except the Scan buttons) when each button is pressed.
- Display tests the pixels on the screen.
- I/O Ctrl tests the external power supply, and gets and sets the VCC state.
- Setup Menu returns to the *Setup* dialog box.

Main Menu

This option returns you to the demo's Main Menu.

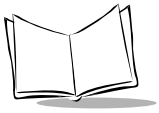

Scanner

The sample scanning application enables the terminal's scanner, allows the user to change scan parameters, and displays scanned data.

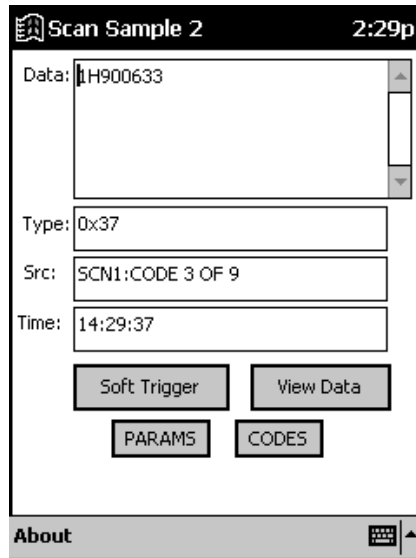

Figure B-5. Scan Sample Dialog Box

Scanning Data Fields

After a bar code is scanned, the following data appears in the dialog box:

- *Data* displays the data encoded in the scanned bar code.
- *Type* indicates the hex type scanned.
- *SRC* indicates the scanner being used, and the bar code type scanned (e.g., Code 128).
- *Time* displays the time the bar code was scanned.

Scanning Options

The following options are available in the Scan dialog box:

- *Soft Trigger* provides an alternative to the trigger buttons on the terminal.
- *View Data* displays the bar code content in a separate screen.
- *Params* is used to change scanning parameter options, such as:
 - beep time (length of decode beep)
 - beeper frequency (tone)
 - LED-on time (length of time LED remains on upon decode)
 - Code ID (AIM, Symbol)
 - Wav File (sound of decode beep).
- *Codes* selects the code types the terminal is able to decode, and sets the options for each code type.
- *Exit* closes the Scan dialog box.

File Explorer

File Explorer is a file browser utility that provides similar Windows Explorer-like functionality on Symbol CE terminals. File Explorer allows the user to browse, cut, copy, paste, and delete files as well as execute the program. It also provides file transfer capability via the IrDA port.

You can also access File Explorer by selecting Programs under the **Start** menu.

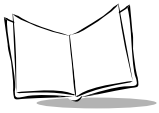

MSR Sample

This selection provides a sample MSR application.



Figure B-6. MSR Sample Dialog Box

CE Apps

Select CE Apps button on the main menu to access the following standard Windows CE applications:

- Voice Recorder
- Calculator
- Solitaire
- Calendar.

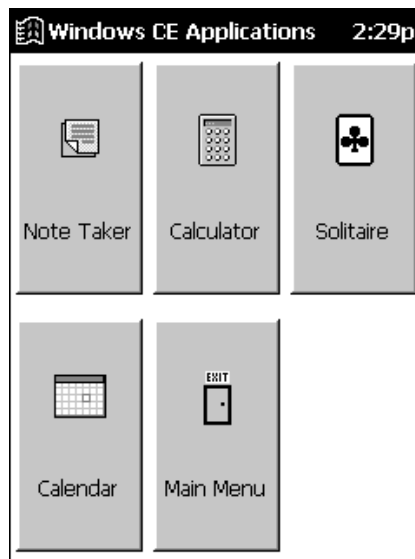
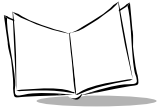

Figure B-7. CE Apps Dialog Box

See [Chapter 5, Applications](#) for information on these applications.

About

Select the **About** button on the demo program to view information about the demo program.



PPT 2700 Series Product Reference Guide

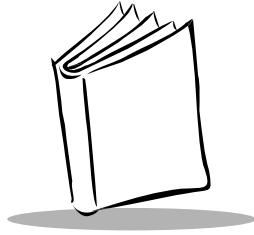

Appendix C

GSM Demo Program

Introduction

GsmDemo allows you to explore what features GSM and the PPT 2734 terminal offer you, including sending and receiving SMS messages.

Using GsmDemo

The first step in using GsmDemo is to configure the PPT 2734 terminal to work with a network.

To start GsmDemo:

1. Select **Programs** from the **Start Menu**.
2. Tap the GSM Demo icon.

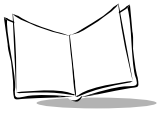

When GsmDemo opens, it opens the internal serial port to the GSM modem and attempts to register with a network. The following screen displays:

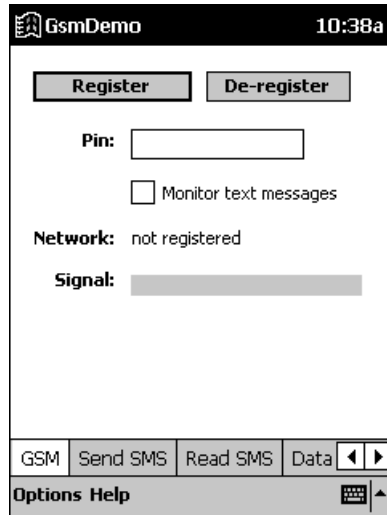

Figure C-1. GSM Screen

- | | |
|--------------------|---|
| Register | Tap to register with the network now. |
| De-register | Tap to end your network session. |
| PIN | Used for security reasons. If your SIM card has this pin enabled, enter your pin number here. |
| Network | There are three possibilities: Not registered, Registered, and Registration failed. |
| Signal | Displays signal strength. |

Working with Text Messages

GsmDemo allows you to send, receive, and view text messages with your PPT 2734 terminal.

Read SMS

To read your SMS messages:

1. Tap the **Read SMS** tab. The following screen displays::

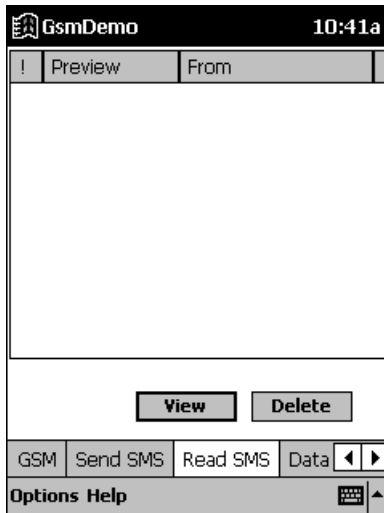
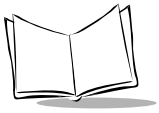

Figure C-2. Read SMS Screen

2. Select a message from the list and tap **View** to read a message. Tap the **OK** button when you are done.
Tap the **Delete** button to delete a message.



Send SMS

To send an SMS message:

1. Tap the **Send SMS** tab.

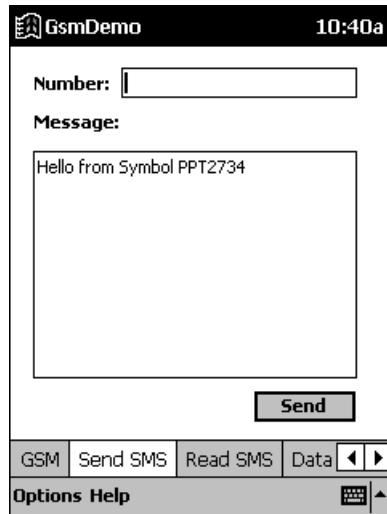

Figure C-3. Send SMS Screen

2. Enter the phone number of the message recipient and the message.
3. Tap **Send** to send the message. A successful message screen displays.

Data

The Data feature is used to test and ensure that the modem can send and receive calls. To test the modem:

1. Select the **Data** tab to display the Data screen..

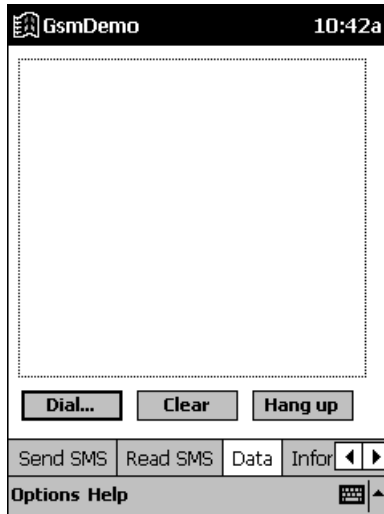

Figure C-4. Data Screen

- | | |
|----------------|--|
| Dial... | Calls another terminal or modem. |
| Clear | Clears any entered commands from the screen. |
| Hangup | Disconnects the session. |

2. Tap the **Dial** button and the **Enter phone number** screen displays:

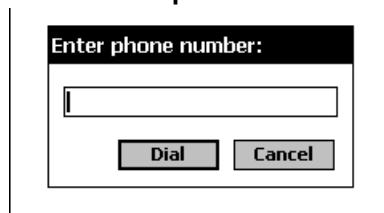
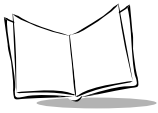

Figure C-5. Enter Phone Number Screen

3. Enter the number and tap the **Dial** button.



Information

The *Information* screen allows you to browse and switch to other networks, and also provides diagnostic information about your modem type and driver version.

To view the Information screen:

1. Select the **Information** tab to display the Information screen.

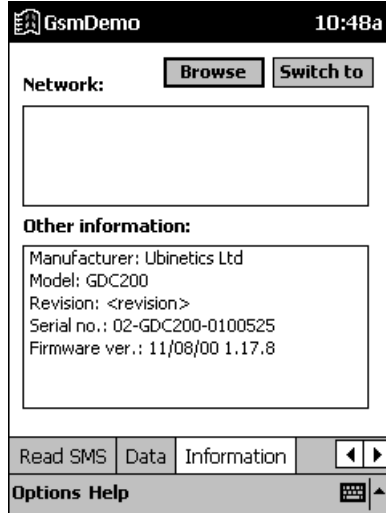

Figure C-6. Information Screen

2. **Other information** displays Manufacturer, Model, Revision, Serial number, and Firmware version, depending upon the modem's registration status. Tap the **Browse** button to browse available networks. The following warning displays:

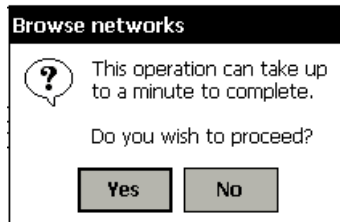

Figure C-7. Browse Network Screen

Note: *If your modem is not registered you will not be able to browse available networks.*

3. Tap the **Yes** button to browse. A screen indicates that the terminal is searching for available networks, then the list of available networks displays.
4. Select the network you want to switch to and tap the **a** button. If the network you attempt to switch to is forbidden, an error displays.

GsmDemo Menu Commands

This section explains the menu commands specific to GsmDemo that make it fast and easy to perform tasks.

Options Menu

The Options menu can be selected from all screens. When you select Options, its commands display on the screen.

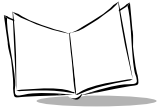

Figure C-8. Options Menu

Set Service Centre Tap to enter the Service Center phone number.

You may need to change the service center phone number if the service center number is missing, its phone number has changed, or you wish to choose an alternate service center. Tap **Set Service Centre**, then enter the new Service Centre Number and click **OK**.

Note: *If your modem is not registered you will receive a “Modem not registered” error and will be unable to proceed.*



Help Menu

The Help menu can be selected from all screens. When you select Help, its commands display on the screen.

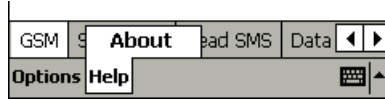

Figure C-9. Help Menu

About

Provides version information for GsmDemo.



Appendix D

Technical Specifications

Environment

Table D-1 summarizes the PPT 2700's intended operating environment.

Table D-1. PPT 2700 Operating Environment

Operating Temperature	-20° C to 50° C (-4° F to 122° F)
Storage Temperature	-25° C to 50° C (-13° F to 122° F)
Humidity	5% to 90% non-condensing
Electrostatic Discharge (ESD)	8 kVdc air; 4 kVdc contact
Drop to Concrete	1.2 meters (4 feet)
Sealing	IP54 (windblown rain and dust)
Decode Distance	3" - 10.5" (7.6 cm - 26.7 cm)
Size	1-D Scanning Terminal: 7"L x 3.625"W x 1"H (177.8mm x 92mm x 25.4mm) 2-D Scanning Terminal: 7.625"L x 3.625"W x 1"D (grip area) x 1.5"D (scanner bay) (193.7mm x 92mm x 25.4mm x 38.1mm)
Weight (including battery)	1-D Scanning Terminal: 10.3 oz / 288 gm (batch); 11.8 oz / 330 gm (wireless) 2-D Scanning Terminal: 13.8 oz / 391 gm (batch); 15.3 oz / 434 gm (wireless)

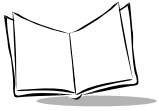

PPT 2700 Series Product Reference Guide

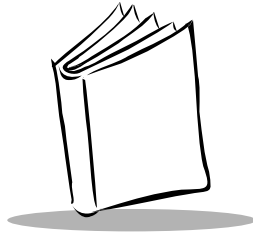

Index

A

ActiveSync	4-2
adding programs to Start menu	3-5
installing	4-1
local operation	4-5
remote	4-6
using cable	4-2
using cradle	4-3
via modem	4-6
adding programs	3-4
to Start menu	3-5
adjusting backlight	2-1
adjusting contrast	2-1
adjusting terminal settings	3-1
aligning screen	1-11
Applications	
GsmDemo	
Data Call	C-4
Information	C-6
Send SMS	C-4
text messages	C-3
GsmDemo Menu Commands	C-7
Help menu	C-8
Options menu	C-7
applications	5-1
calendar	5-2
meeting requests	5-4
summary screen	5-4
contacts	5-5
summary screen	5-7
inbox	5-13
connecting to e-mail server	5-13
creating messages	5-17
managing	5-18

message list	5-15
synchronizing e-mail	5-13
notes	5-11
tasks	5-8
summary screen	5-10
appointments	5-2
attaching handstrap	1-9

B

batteries	
charging	1-5
charging spare batteries	1-7
charging using cable	1-7
installing	1-4
removing battery cover	1-4
booting	
cold	2-13
warm	2-12
BSS ID	8-10
buttons	
function	2-1
power	1-11, 2-1

C

cables	
connecting power cable	1-8
inserting in terminal	1-8, 4-2
performing ActiveSync	4-2
synchronization	1-7
calendar application	5-2
creating appointments	5-2
meeting requests	5-4
summary screen	5-4

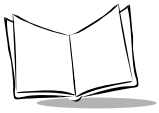

CE applications	B-9	file explorer	B-7
channels	6-3	MSR sample	B-8
chapter descriptions	ix	NICTT	B-4
character chart	A-3	scanner	B-6
character recognizer	2-7, A-1	setup	B-3
charging batteries	1-5	disconnecting	7-6
spare battery	1-7	drawing on screen	2-8
using cable	1-7		
using cradle	1-5	E	
cleaning terminal	12-2	e-mail connection	7-6
command bar	2-5	creating messages	5-17
icons	2-3	inbox	5-13
communications	4-1	entering characters	2-7
ActiveSync	4-2	entering information	2-6
connecting	7-1	drawing on screen	2-8
disconnecting	7-6	recording message	2-9
infrared	7-2	writing on screen	2-7
to development PC	11-10	entering text	2-6
to e-mail server	7-6	error messages	11-16, 11-17
to ISP	7-2		
to network	7-4	F	
via modem	7-4	favorite links	6-1
contacting Symbol	xi	file explorer	2-10, B-7
contacts application	5-5	finding information	2-10
summary screen	5-7	flash file system	3-2
cradle		downloading partitions	3-4
charging batteries	1-5	non-FFS partitions	3-3
charging spare batteries	1-7	IPL	3-4
connecting	4-4	splash screen	3-4
connecting power supply	1-5	partitions	3-2
connecting to host	1-6	copyfile	3-3
inserting terminal	1-6, 4-5	regmerge	3-3
performing ActiveSync	4-2, 4-3	function button	2-1
performing modem ActiveSync	4-6		
creating messages	5-17	G	
creating splash screen	11-19	GsmDemo	
customizing the PPT 2700	3-1	text messages	
		Read SMS	C-3
D			
demo program	B-1, C-1	H	
CE applications	B-9	handstrap	
control panel	B-3	attaching	1-9
diagnostics	B-5		

I

icons

- status 2-3
- inbox application 5-13, 5-17
 - connecting to e-mail server 5-13
 - managing 5-18
 - message list 5-15
 - synchronizing e-mail 5-13
- infrared connection 7-2
- Initial Program Loader 3-4, 11-10
- input panel 2-6
 - character recognizer 2-7
- installing SDK 10-1
- IPL 3-4, 11-10
 - error messages 11-16
 - setup 11-11
- ISP connection 7-2

L

- loading applications 11-10
- loading software 11-10
- loading splash screen 11-20

M

- maintaining terminal 12-1
- mobile channels 6-3
- mobile favorites 6-1, 6-5
 - creating 6-2
- mobile unit properties 8-10
- modem connection 7-4
- MSR B-8

N

- navigation bar 2-5
- network
 - configuring CDPD WAN 9-1
 - configuring GSM WAN 9-17
- network connection 7-4
 - via modem 7-4
- NIC ESSID 8-10
- NICTT

- demo program B-4
- general properties 8-4
- info properties 8-16
- introduction 8-1
- options properties 8-8, 8-17
- power properties 8-5, 8-15
- signal strength properties 8-6, 8-19
- transmission quality properties .. 8-6, 8-18

- notational conventions x
- notes application 5-11

O

- operating environment D-1

P

partitions

- downloading 3-4
- FFS 3-2
- non-FFS 3-3
 - IPL 3-4
 - splash screen 3-4

- parts of PPT 2700 1-2

PDF417

- raster 2-11
- scanning 2-11

- Pocket Internet Explorer 6-1

- browsing web 6-6
- channels 6-3
- favorite links 6-1
- mobile favorites 6-1, 6-5
 - using 6-4

- pop-up menus 2-5

- power button 1-11, 2-1

power cable

- connecting 1-8

programs

- adding 3-4
- adding and removing 3-2
- adding to Start menu 3-5
- flash file system 3-2
- removing 3-6
- selecting 2-4

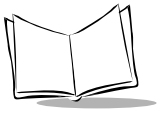

R

recording	2-9
removing programs	3-6
resetting	2-12
cold boot	2-13
warm boot	2-12

S

S24 Settings Control Panel Applet	8-1
scanning	2-11
2D bar codes	2-11
raster	2-11
scripts	
building	11-8
checking	11-8
creating	11-6
demo,samples	11-1
opening in TCM	11-6
saving	11-7
standard	11-1
SDK	10-1
installing	10-2
installing on development PC	10-2
system requirements	10-1
selecting a drawing	2-8
selecting programs	2-4
selecting text	2-7
selecting writing	2-8
service information	xi
settings	
adjusting	3-1
specifications	D-1
Spectrum24	
configuring	8-1
configuring PPT 2740 and 2742	8-4
setup	8-9
Spectrum24 Settings Control Panel	
Applet	8-9, 8-20
advanced settings	8-21
encryption settings	8-24
mobile unit properties	8-10, 8-21
power properties	8-23
WLAN adapter settings	8-12, 8-25

splash screen	3-4
creating	11-19
loading	11-20
Start menu	
adding programs	3-5
selecting programs	2-4
starting the PPT 2700	1-11
status icons	2-3
stylus	2-2
synchronization cable	1-7
connecting	1-8, 4-2

T

tasks application	5-8
summary screen	5-10
TCM	11-1
building hex image	11-1, 11-8, 11-9
components	11-3
creating script	11-6
defining properties	11-4
error messages	11-17
file browser window	11-3
hex image download	11-10
loading splash screen	11-20
saving script	11-7
script window	11-3
starting	11-2
tool bar	11-3
technical specifications	D-1
Terminal Configuration Manager	11-1
Today screen	2-3
tools and utilities	
NICTT	8-2
Spectrum24 Settings Control Panel	
Applet	8-3, 8-9, 8-20
troubleshooting	12-2

U	
unpacking	1-1
using stylus	2-2
using the PPT 2700	2-1, 5-1
scanning	2-11

W

web browser 6-6
writing on screen 2-7
WWAN

configuring 9-1
configuring CDPD 9-1
configuring GSM 9-17

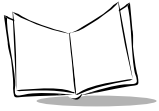

PPT 2700 Series Product Reference Guide

Tell Us What You Think...

We'd like to know what you think about this Manual. Please take a moment to fill out this questionnaire and fax this form to: (631) 738-3318, or mail to:

Symbol Technologies, Inc.
One Symbol Plaza M/S B-4
Holtsville, NY 11742-1300
Attention: Technical Publications Manager

IMPORTANT: If you need product support, please call the appropriate customer support number provided. Unfortunately, we cannot provide customer support at the fax number above.

User's Manual Title: _____
(please include revision level)

How familiar were you with this product before using this manual?

Very familiar Slightly familiar Not at all familiar

Did this manual meet your needs? If not, please explain.

What topics need to be added to the index, if applicable?

What topics do you feel need to be better discussed? Please be specific.

What can we do to further improve our manuals?

