

QRG
L S 4 0 0 8 i



symbol[®]



© 2002 SYMBOL TECHNOLOGIES, INC. All rights reserved.

Symbol reserves the right to make changes to any product to improve reliability, function, or design.

Symbol does not assume any product liability arising out of, or in connection with, the application or use of any product, circuit, or application described herein.

No license is granted, either expressly or by implication, estoppel, or otherwise under any patent right or patent, covering or relating to any combination, system, apparatus, machine, material, method, or process in which Symbol products might be used. An implied license exists only for equipment, circuits, and subsystems contained in Symbol products.

Symbol and the Symbol logo are registered trademarks of Symbol Technologies, Inc. Other product names mentioned in this manual may be trademarks or registered trademarks of their respective companies and are hereby acknowledged.

Symbol Technologies, Inc.
One Symbol Plaza
Holtsville, N.Y. 11742-1300
<http://www.symbol.com>

Patents

This product is covered by one or more of the following U.S. and foreign Patents:

U.S. Patent No. 4,593,186; 4,603,262; 4,607,156; 4,652,750; 4,673,805; 4,736,095; 4,758,717; 4,760,248; 4,806,742; 4,816,660; 4,845,350; 4,896,026; 4,897,532; 4,923,281; 4,933,538; 4,992,717; 5,015,833; 5,017,765; 5,021,641; 5,029,183; 5,047,617; 5,103,461; 5,113,445; 5,130,520; 5,140,144; 5,142,550; 5,149,950; 5,157,687; 5,168,148; 5,168,149; 5,180,904; 5,216,232; 5,229,591; 5,230,088; 5,235,167; 5,243,655; 5,247,162; 5,250,791; 5,250,792; 5,260,553; 5,262,627; 5,262,628; 5,266,787; 5,278,398; 5,280,162; 5,280,163; 5,280,164; 5,280,498; 5,304,786; 5,304,788; 5,306,900; 5,324,924; 5,337,361; 5,367,151; 5,373,148; 5,378,882; 5,396,053; 5,396,055; 5,399,846; 5,408,081; 5,410,139; 5,410,140; 5,412,198; 5,418,812; 5,420,411; 5,436,440; 5,444,231; 5,449,891; 5,449,893; 5,468,949; 5,471,042; 5,478,998; 5,479,000; 5,479,002; 5,479,441; 5,504,322; 5,519,577; 5,528,621; 5,532,469; 5,543,610; 5,545,889; 5,552,592; 5,557,093; 5,578,810; 5,581,070; 5,589,679; 5,589,680; 5,608,202; 5,612,531; 5,619,028; 5,627,359; 5,637,852; 5,664,229; 5,668,803; 5,675,139; 5,693,929; 5,698,835; 5,705,800; 5,714,746; 5,723,851; 5,734,152; 5,734,153; 5,742,043; 5,745,794; 5,754,587; 5,762,516; 5,763,863; 5,767,500; 5,789,728; 5,789,731; 5,808,287; 5,811,785; 5,811,787; 5,815,811; 5,821,519; 5,821,520; 5,823,812; 5,828,050; 5,848,064; 5,850,078; 5,861,615; 5,874,720; 5,875,415; 5,900,617; 5,902,989; 5,907,146; 5,912,450; 5,914,478; 5,917,173; 5,920,059; 5,923,025; 5,929,420; 5,945,658; 5,945,659; 5,946,194; 5,959,285; 6,002,918; 6,021,947; 6,029,894; 6,031,830; 6,036,098; 6,047,892; 6,050,491; 6,053,413; 6,056,200; 6,065,678; 6,067,297; 6,082,621; 6,084,528; 6,088,482; 6,092,725; 6,101,483; 6,102,293; 6,104,620; 6,114,712; 6,115,678; 6,119,944; 6,123,265; 6,131,814; 6,138,180; 6,142,379; 6,172,478; 6,176,428; 6,178,426; 6,186,400; 6,188,681; 6,209,788; 6,209,789; 6,216,951; 6,220,514; 6,243,447; 6,244,513; 6,247,647; 6,308,061 6,250,551; 6,295,031; 6,308,061; 6,308,892; 6,321,990; 6,328,213; 6,330,244; 6,336,587; 6,340,114; 6,340,115; 6,340,119; 6,348,773; D305,885; D341,584; D344,501; D359,483; D362,453; D363,700; D363,918; D370,478; D383,124; D391,250; D405,077; D406,581; D414,171; D414,172; D418,500; D419,548; D423,468; D424,035; D430,158; D430,159; D431,562; D436,104.

Invention No. 55,358; 62,539; 69,060; 69,187 (Taiwan); No. 1,601,796; 1,907,875; 1,955,269 (Japan); European Patent 367,299; 414,281; 367,300; 367,298; UK 2,072,832; France 81/03938; Italy 1,138,713
rev. 03/02

Introduction

The LS 4008i is the result of Symbol's experience in the design of innovative, high performance scanning solutions. The LS4008i brings superior bar code scanning performance with maximum user comfort at a highly attractive price that's backed by a five-year plus warranty.

Parts of the LS4008i Series Scanner

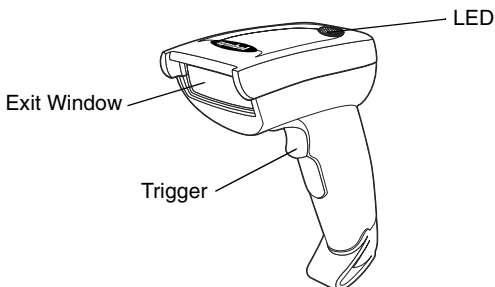

Installing the Interface Cable

1. Plug the interface cable modular connector into the cable interface port on the bottom of the scanner handle.

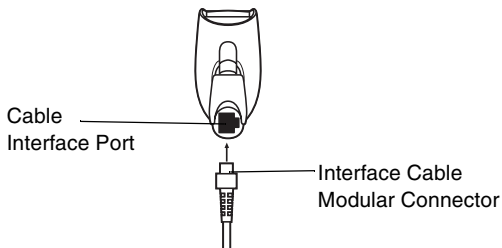

2. Connect the other end of the interface cable to the host.
3. Connect the power supply to the cable (if necessary).
4. Scan the appropriate bar code(s) beginning on page 37 to communicate with the host.

Removing the Interface Cable

Unplug the installed cable's modular connector by depressing the connector clip with the tip of a screwdriver.

Aiming

Note: The scanner performs best when it is not exactly perpendicular to the bar code.

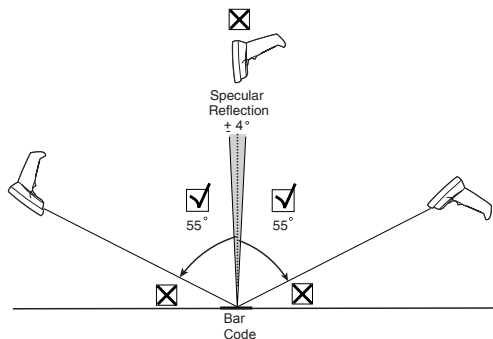

Scanning In Hand-Held Mode

1. Ensure all connections are secure.
2. Aim the scanner at the bar code. (If your scanner has a trigger, aim the scanner and press the trigger.)
3. Ensure the scan line crosses every bar and space of the symbol.



4. Upon successful decode, the scanner beeps and the LED turns green.

Scanning in Hands-Free Mode

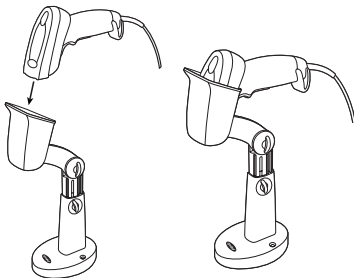

In the stand, the scanner is in constant-on mode. When you remove the scanner from the stand it operates in its normal hand-held mode.

1. Insert scanner in stand.
2. Present bar code and ensure the scan line crosses every bar and space of the symbol.
3. Upon successful decode, the scanner beeps and the LED turns green.

Troubleshooting

Problem	Possible Cause	Possible Solutions
Nothing happens when you follow the operating instructions.	No power to the scanner.	Check the system power. Ensure the power supply is connected if your configuration requires a power supply.
	Interface/power cables are loose.	Check for loose cable connections.
Laser comes on, but symbol does not decode.	Scanner is not programmed for the correct bar code type.	Be sure the scanner is programmed to read the type of bar code you are scanning.

Problem	Possible Cause	Possible Solutions
	Bar code symbol is unreadable.	Check the symbol to make sure it is not defaced. Try scanning test symbols of the same bar code type.
	Distance between scanner and bar code is incorrect.	Move the scanner closer to the bar code.
Symbol is decoded, but not transmitted to the host.	Scanner is not programmed for the correct host type.	Scan the appropriate host type bar code.
Scanned data is incorrectly displayed on the host.	Scanner is not programmed to work with the host. Check scanner host type parameters or editing options.	<p>Be sure proper host is selected.</p> <p>For RS-232, ensure the scanner's communication parameters match the host's settings.</p> <p>For a keyboard wedge configuration, ensure the system is programmed for the correct keyboard type, and the CAPS LOCK key is off.</p> <p>Be sure editing options (e.g., UPC-E to UPC-A Conversion) are properly programmed.</p>

Présentation

Le LS 4008i est né de l'expérience de Symbol dans la conception de solutions de lecture innovantes et performantes. Il permet une lecture optimale des codes à barres avec un maximum de confort pour l'utilisateur, à un prix irrésistible et doublé d'une garantie de cinq ans.

Composants du lecteur de la série LS4008i

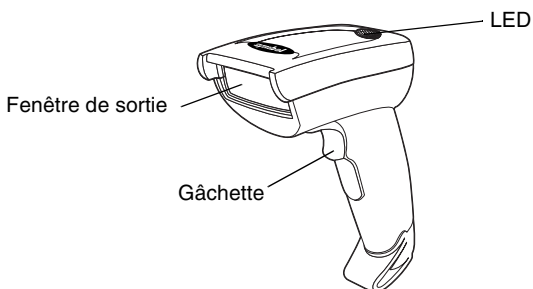

Installation du câble d'interface

1. Branchez le connecteur modulaire du câble d'interface au port correspondant sur la partie inférieure de la poignée du lecteur.

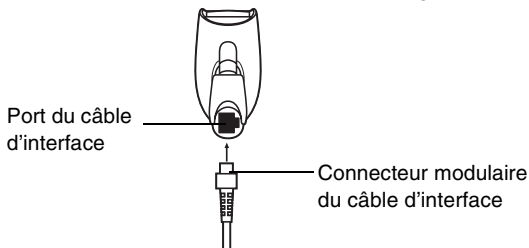

2. Connectez l'autre extrémité du câble à l'ordinateur central.
3. Branchez l'alimentation au câble (si nécessaire).
4. Lisez les codes à barres correspondants à la page 37 pour communiquer avec l'ordinateur central

Dépose du câble d'interface

Débranchez le connecteur modulaire du câble d'interface installé en appuyant sur le clip du connecteur avec l'extrémité d'un tournevis.

Visée

Remarque : On obtient les meilleures performances de décodage lorsque le lecteur n'est pas totalement perpendiculaire au code à barres.

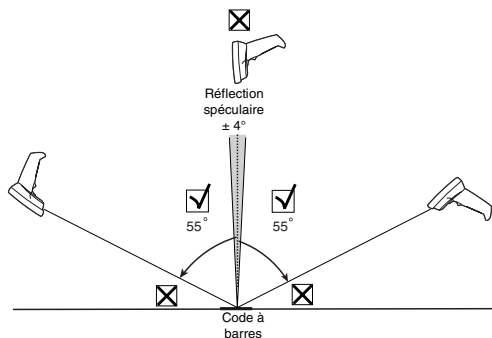

Lecture en mode portable

1. Vérifiez tous les branchements.
2. Pointez le lecteur sur le code à barres. (Si votre lecteur est muni d'une gâchette, visiez, puis appuyez sur la gâchette.)
3. Assurez-vous que le faisceau de lecture recouvre toutes les lignes et tous les espaces qui composent le code.



4. Lorsque le décodage est réalisé, le lecteur émet un bip sonore et le témoin vire au vert.

Lecture en mode mains-libres

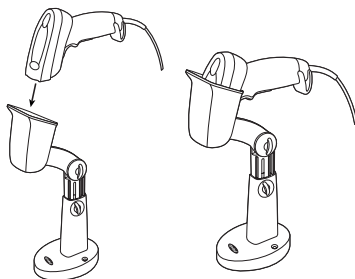

Lorsqu'il est inséré dans son support, le lecteur est activé en permanence. Lorsque vous l'extrayez de son support, il se replace en mode portable normal.

1. Insérez le lecteur dans son support.
2. Présentez le code et assurez-vous que le faisceau de lecture recouvre toutes les lignes et tous les espaces qui le composent.
3. Lorsque le décodage est réalisé, le lecteur émet un bip sonore et le témoin vire au vert.

Dépannage

Problème	Cause probable	Solutions possibles
Vous avez suivi les instructions d'utilisation, mais rien ne se produit.	Le lecteur n'est pas alimenté.	Vérifiez l'alimentation du système. Assurez-vous que l'alimentation est raccordée si votre configuration l'utilise.
	Les câbles d'interface/ d'alimentation sont mal branchés.	Vérifiez que les câbles sont correctement branchés.

Problème	Cause probable	Solutions possibles
Le faisceau est activé mais le code n'est pas déchiffré.	Le lecteur n'est pas programmé pour le bon type de code à barres.	Assurez-vous que le lecteur est programmé pour accepter le type de code à barres que vous tentez de lire.
	Le code à barres est illisible.	Vérifiez que le code à barres est en bon état. Essayez de lire des codes du même type.
	Distance incorrecte entre le lecteur et le code à barres.	Rapprochez ou éloignez le lecteur du code à barres.
Le code est lu mais il n'est pas transmis à l'ordinateur central.	Le lecteur n'est pas programmé pour le type d'ordinateur qui convient.	Lisez le code à barres correspondant à l'ordinateur en question.
L'affichage des données lues sur l'ordinateur central est incorrect.	Le lecteur n'est pas programmé pour utiliser cet ordinateur central. Vérifiez les paramètres du type d'ordinateur ou les options d'édition.	<p>Vérifiez que l'ordinateur central correct est sélectionné.</p> <p>Pour le RS-232, vérifiez que les paramètres de communication du lecteur correspondent aux réglages de l'ordinateur.</p> <p>Pour une configuration d'émulation clavier, assurez-vous que le système est programmé pour le bon type de clavier, et que la touche de verrouillage des majuscules est désactivée.</p> <p>Vérifiez que les options d'édition (ex. conversion UPC-E/UPC-A) sont correctement programmées.</p>

Einführung

Der LS 4008i ist das Ergebnis von Symbol's langjähriger Erfahrung bei der Herstellung von innovativen Hochleistungsscannern. Der LS 4008i bietet eine einzigartige Leistungsfähigkeit beim Lesen von Barcodes und maximalen Benutzerkomfort. Das Gerät ist zu einem sehr attraktiven Preis im Handel erhältlich.

Die Teile der Scanner der Serie LS4008i

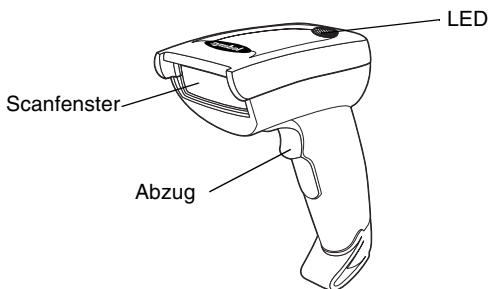

Installieren des Schnittstellenkabels

1. Stecken Sie das Schnittstellenkabel in den Kabelanschluss am Griffboden des Scanner.

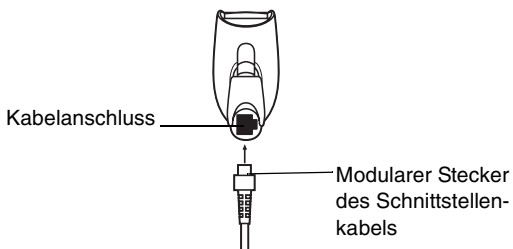

2. Verbinden Sie das andere Ende des Kabels mit dem Host.
3. Schließen Sie gegebenenfalls das Netzkabel an.
4. Scannen Sie den bzw. die entsprechenden Barcode(s), beginnend auf Seite 37, um die Kommunikation mit dem Host zu starten.

Abziehen des Schnittstellenkabels

Drücken Sie zum Herausziehen des modularen Steckers die Anschlussklemme mit der Klinge eines Schraubenziehers nach unten.

Zielen

Hinweis: Die besten Scanleistungen werden erzielt, wenn Sie den Scanner nicht exakt senkrecht auf den Barcode richten.

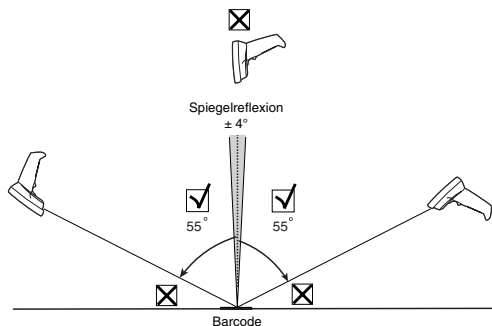

Scannen mit dem Handscanner

1. Vergewissern Sie sich, dass alle Anschlüsse festsitzen.
2. Zielen Sie mit dem Scanner auf den Barcode. (Wenn Ihr Scanner mit einem Abzug ausgestattet ist, zielen Sie mit dem Scanner, und betätigen Sie dann den Abzug.)
3. Es muss gewährleistet sein, dass die Scanzeile alle Balken und Zwischen-räume des Symbols überstreicht.



4. Nach erfolgreichem Decodieren gibt der Scanner einen Piepton ab, und die grüne LED wird aktiviert.

Scannen im Freihandmodus

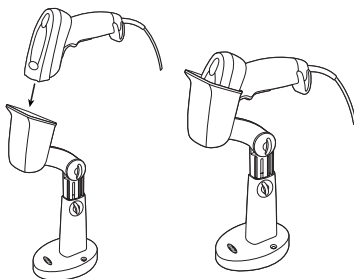

Im Tischständer bleibt der Scanner konstant eingeschaltet. Wenn Sie den Scanner aus dem Ständer nehmen, schaltet er in den normalen Handbetrieb um.

1. Setzen Sie den Scanner in den Ständer ein.
2. Halten Sie den Barcode vor den Scanner. Es muss gewährleistet sein, dass die Scanzelle alle Balken und Zwischenräume des Symbols überstreicht.
3. Nach erfolgreichem Decodieren gibt der Scanner einen Piepton ab, und die grüne LED wird aktiviert.

Fehlerbehebung

Problem	Mögliche Ursache	Mögliche Lösungen
Sie gehen exakt nach der Bedienungsanleitung vor, und trotzdem passiert nichts.	Stromversorgung zum Scanner unterbrochen.	Überprüfen Sie die Stromversorgung des Systems. Stellen Sie sicher, dass die Stromversorgung angeschlossen ist (sofern Ihr System über einen Netzanschluss arbeitet).
	Schnittstellen- oder Stromkabel sind lose.	Überprüfen Sie, ob eventuell Kabelverbindungen lose sind.

Problem	Mögliche Ursache	Mögliche Lösungen
Der Laserstrahl wird aktiviert, jedoch das Symbol nicht decodiert.	Der Scanner ist für den betreffenden Barcode-Typ nicht programmiert.	Stellen Sie sicher, dass das Gerät so programmiert wurde, dass es den Barcode-Typ, der gescannt werden soll, auch lesen kann.
	Der Barcode ist unleserlich.	Überprüfen Sie das Symbol auf Deformierungen. Versuchen Sie, Testsymbole desselben Barcode-Typs zu scannen.
	Der Abstand zwischen Scanner und Barcode ist nicht korrekt.	Bewegen Sie den Scanner dichter an oder weiter weg vom Barcode.
Das Symbol wird decodiert, jedoch nicht an den Host übertragen.	Der Scanner ist für den betreffenden Host-Typ nicht programmiert.	Programmieren Sie ggf. den Scanner auf den betreffenden Barcode-Typ.
Die gescannten Daten werden am Host nicht korrekt angezeigt.	Der Scanner ist für ein Zusammenwirken mit dem Host nicht programmiert. Überprüfen Sie die Host-parameter bzw. die Bearbeitungsoptionen.	<p>Stellen sie sicher, dass der richtige Host ausgewählt ist.</p> <p>Gewährleisten Sie, dass für RS-232 die Kommunikationsparameter des Scanners den Host-Einstellungen entsprechen.</p> <p>Stellen Sie sicher, dass bei einer Tastaturweichen-Konfiguration das System für den richtigen Tastaturtyp programmiert ist, und dass die FESTSTELLTASTE deaktiviert ist.</p> <p>Vergewissern Sie sich, dass die Bearbeitungsoptionen (z. B. Konvertierung von UPC-E zu UPC-A) korrekt programmiert sind.</p>

Introduzione

Lo scanner della Serie LS 4008i è il risultato dell'esperienza che Symbol ha maturato nel campo della progettazione di soluzioni di scansione innovative e dalle elevate prestazioni. Lo scanner LS4008i garantisce livelli di efficienza eccezionali nella scansione di codici a barre, oltre ad offrire la massima comodità d'uso a un prezzo decisamente interessante e ben cinque anni di garanzia.

Le parti dello scanner Serie LS4008i



Installazione del cavo di interfaccia

1. Inserire il connettore modulare del cavo di interfaccia nella relativa porta, nella parte inferiore del manico dello scanner.

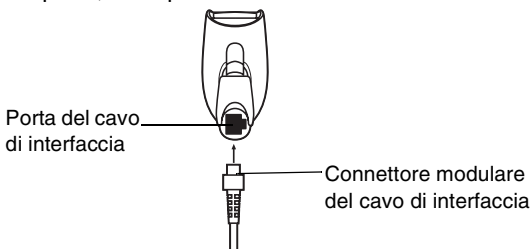

2. Collegare l'altra estremità del cavo di interfaccia all'host.
3. Collegare il cavo all'alimentazione, se necessario.
4. Eseguire la scansione del codice o dei codici a barre riportati a pagina 37 per comunicare con l'host.

Rimozione del cavo di interfaccia

Scollegare il connettore modulare del cavo installato premendo il fermaglio del connettore con la punta di un cacciavite.

Mira

Nota: Lo scanner funziona meglio quando non è esattamente perpendicolare al codice a barre.

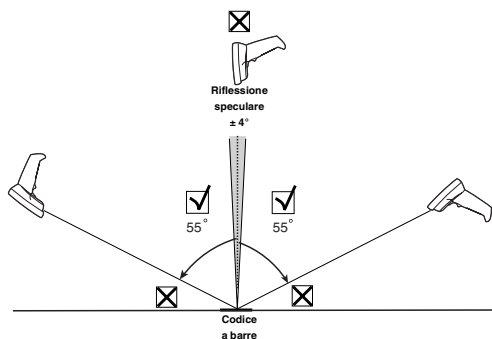

Modalità di scansione portatile

1. Assicurarsi che tutte le connessioni siano fissate.
2. Mirare lo scanner al codice a barre. Se lo scanner ha un grilletto, mirare lo scanner e premere tale grilletto.
3. Assicurarsi che la linea di scansione incroci ogni barra e ogni spazio del simbolo.

CORRETTO



012345

ERRATO



012345

4. Dopo la decodifica con esito positivo, lo scanner emette un segnale acustico e il LED assume il colore verde.

Modalità di scansione “a mani libere”

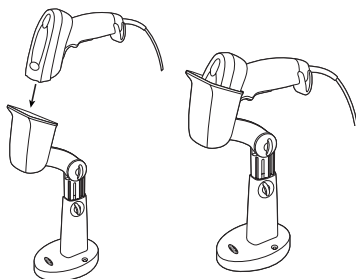

Nel supporto, lo scanner è in modalità sempre attiva. Quando lo scanner viene tolto dal supporto, funziona nella sua normale modalità portatile, ossia nella modalità sempre attiva o nella modalità “con grilletto”, a seconda del modello.

1. Inserire lo scanner nel supporto.
2. Presentare il codice a barre e assicurarsi che la linea di scansione incroci ogni barra e ogni spazio del simbolo.
3. Dopo la decodifica con esito positivo, lo scanner emette un segnale acustico e il LED assume il colore verde.

Risoluzione dei problemi

Problema	Possibile causa	Possibile soluzione
Quando si eseguono le istruzioni d'uso, non accade nulla.	Lo scanner non riceve alimentazione.	Controllare l'alimentazione del sistema. Verificare il collegamento dell'alimentazione se questa è richiesta dalla configurazione.
	La connessione dei cavi di interfaccia/ alimentazione è difettosa.	Controllare se la connessione del cavo è difettosa.

Problema	Possibile causa	Possibile soluzione
Il laser è attivo, ma il simbolo non viene decodificato.	Lo scanner non è programmato per il corretto tipo di codice a barre.	Assicurarsi che lo scanner sia programmato in modo da leggere il tipo di codice a barre da leggere.
	Il codice a barre è illeggibile.	Controllare il simbolo per assicurarsi che non sia danneggiato. Eseguire la lettura di simboli simili dello stesso tipo di codice a barre.
	La distanza tra lo scanner e il codice a barre non è corretta.	Avvicinare o allontanare lo scanner al o dal codice a barre.
Il simbolo viene decodificato ma non viene trasmesso all'host.	Lo scanner non è programmato per il corretto tipo di host.	Eseguire la lettura del codice a barre del tipo di host corretto.
I dati letti vengono visualizzati in modo errato sull'host.	Lo scanner non è programmato per funzionare con l'host. Verificare le opzioni o i parametri del tipo di host dello scanner.	<p>Assicurarsi che l'host appropriato sia stato selezionato.</p> <p>Sul modello RS-232, assicurarsi che i parametri di comunicazione dello scanner corrispondano a quelli dell'host.</p> <p>Per una configurazione keyboard wedge, assicurarsi che il sistema sia programmato per il tipo di tastiera appropriato, e il tasto CAPS LOCK non sia selezionato.</p> <p>Assicurarsi anche che le opzioni di revisione (per esempio la conversione da UPC-E a UPC-A) siano correttamente selezionate.</p>

Introducción

El LS 4008i es el resultado de la experiencia de Symbol en el diseño de soluciones de lectura innovadoras y de alto rendimiento. El LS4008i ofrece unas prestaciones de lectura de códigos de barras excelentes y máximo confort a un precio muy atractivo, respaldado por una garantía de cinco años ampliable.

Partes del scanner de la serie LS4008i

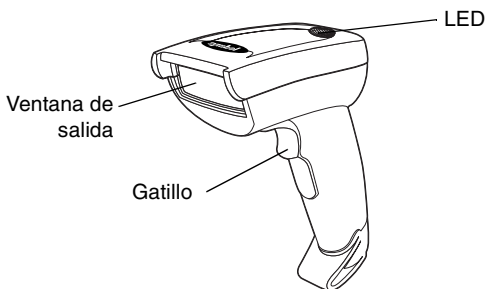

Instalación del cable de interfaz

1. Enchufe el conector modular del cable de interfaz al puerto de interfaz del cable situado en la base del mango del lector de códigos de barras.

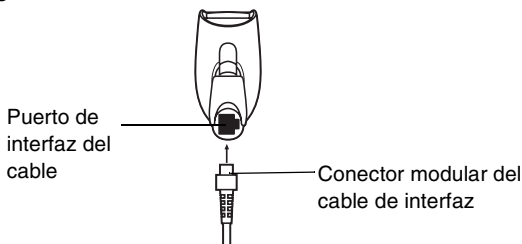

2. Conecte el otro extremo del cable de interfaz al host.
3. Conecte la fuente de alimentación al cable (si fuese necesario)
4. Realice una lectura del código o códigos de barras apropiados que comienzan en la página 37 para establecer la comunicación con el host.

Extracción del cable de interfaz

Desconecte el conector modular del cable instalado apretando la lengüeta del conector con la punta de un destornillador.

Apuntado

Nota: El scanner ofrece un mayor rendimiento cuando no está situado exactamente en dirección perpendicular al código de barras.

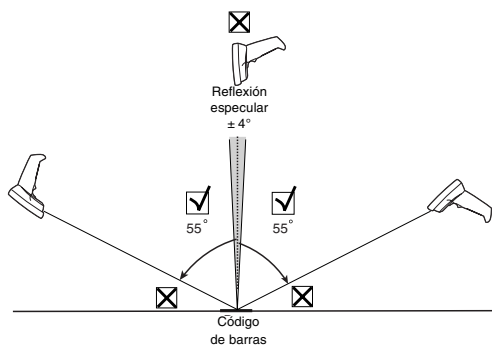

Lectura en modo manual

1. Compruebe que todas las conexiones estén firmes.
2. Apunte el scanner hacia el código de barras. (Si su scanner tiene gatillo, apunte el scanner y presione el gatillo.)
3. Compruebe que la línea de lectura cruce todas las barras y espacios del símbolo.



4. Si la decodificación es satisfactoria, el scanner emite un pitido y el LED se pone verde.

Lectura en modo manos libres

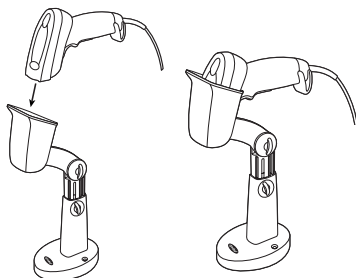

El scanner está continuamente encendido cuando está colocado en el soporte. Al retirar el scanner del soporte, funciona en el modo manual normal.

1. Coloque el scanner en el soporte.
2. Exponga el código de barras y compruebe que la línea de lectura cruce todas las barras y espacios del símbolo.
3. Si la decodificación es satisfactoria, el scanner emitirá un pitido y el LED se pondrá verde.

Solución de problemas

Problema	Causa posible	Soluciones posibles
No ocurre nada al seguir las instrucciones de funcionamiento.	El scanner no recibe alimentación.	Compruebe la alimentación del sistema. Compruebe que la fuente de alimentación esté conectada, si su configuración necesita una fuente de alimentación.
	Los cables de interfaz/ alimentación están sueltos.	Compruebe que las conexiones de cables no estén sueltas.

Problema	Causa posible	Soluciones posibles
El láser se enciende pero no decodifica.	El scanner no está programado para el tipo adecuado de código de barras.	Asegúrese de que el scanner esté programado para leer el tipo de código de barras que está intentando leer.
	El código de barras es ilegible.	Compruebe que el código no esté desfigurado. Trate de leer códigos de barras de prueba con el mismo tipo de código.
	La distancia entre el scanner y el código de barras es incorrecta.	Acerque o aleje el scanner del código de barras.
El código de barras está decodificado pero no se transmite al host.	El scanner no está programado para el tipo de host adecuado.	Realice una lectura del código de barras del tipo de host adecuado.
Los datos leídos están mal presentados en el host.	El scanner no está programado para trabajar con el host. Compruebe los parámetros o las opciones de edición del tipo de host.	<p>Verifique que el host adecuado esté seleccionado.</p> <p>Para RS-232, compruebe que los parámetros de comunicación del scanner coincidan con la configuración del host.</p> <p>Para la configuración de la emulación de teclado, compruebe que el sistema esté programado para el tipo de teclado adecuado, y que la tecla Bloq Mayús esté desactivada.</p> <p>Asegúrese de que las opciones de edición estén correctamente programadas (por ejemplo, conversión UPC-E a UPC-A).</p>

Introdução

O LS 4008i é o resultado da experiência da Symbol no projeto de soluções de leitura inovadoras e de alto desempenho. O LS4008i combina um desempenho superior na leitura de códigos de barras com o máximo conforto do usuário, por um preço altamente acessível e com o respaldo de uma garantia de mais de 5 anos.

Peças scanner da série LS4008i

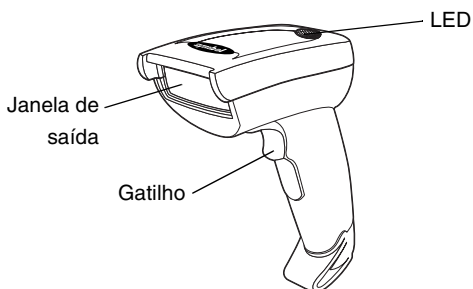

Instalação do cabo de interface

1. Encaixe o conector modular do cabo de interface na porta do cabo de interface na parte inferior da alça da leitor.

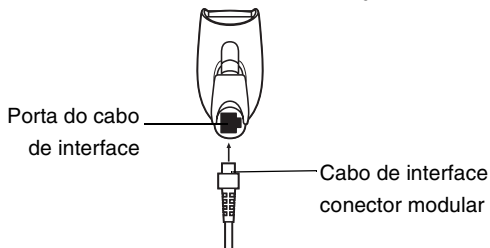

2. Conecte a outra extremidade do cabo de interface ao host.
3. Conecte a fonte de alimentação ao cabo (se necessário).
4. Leia o(s) código(s) de barras adequado(s) começando na pagina 37 para comunicar-se com o host.



Remoção do cabo de interface

Desencaixe o conector modular do cabo instalado pressionando o clipe do conector com a ponta de uma chave de fenda.

Direcionamento

Nota: O melhor desempenho do scanner é quando ele não está exatamente perpendicular ao código de barras.

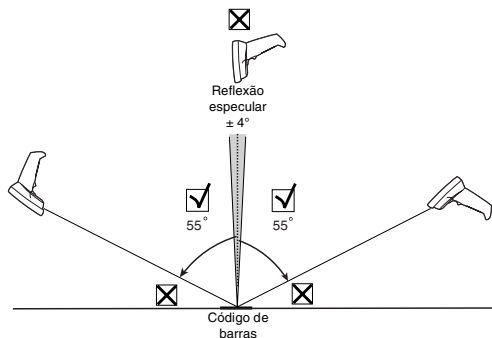

Leitura em modo manual

1. Verifique se todos os conectores estão firmes.
2. Direcione o scanner para o código de barras. (Se o scanner possui um gatilho, direcione o scanner e pressione o gatilho).
3. Assegure-se de que a linha de leitura passe por cada barra e espaço do código.



4. Se a leitura for bem-sucedida, o scanner emite um bipe e o LED torna-se verde.

Leitura em modo automático

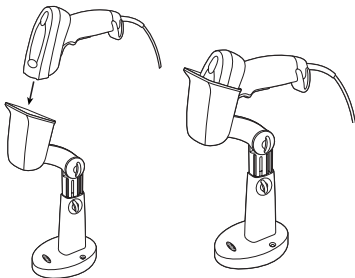

No suporte, o scanner fica permanentemente ligado. Quando você remove o scanner do suporte ele opera em modo manual normal.

1. Encaixe o scanner no suporte.
2. Direcione-o ao código de barras e certifique-se de que a linha de leitura passe por todas as barras do código.
3. Se a leitura for bem-sucedida, o scanner emite um bipe e o LED torna-se verde.

Solução de problemas

Problema	Causa provável	Soluções possíveis
Nada acontece ao seguir as instruções de operação.	Não há alimentação para o scanner.	Verifique a alimentação do sistema. Se sua configuração exige alimentação, verifique se a fonte de alimentação está conectada.
	Os cabos de interface/ alimentação estão frouxos.	Verifique se os cabos de conexão estão bem encaixados.
O laser acende, mas não lê o código.	O scanner não está programado para o tipo correto de código de barras.	Verifique se o scanner está programado para ler o tipo de código de barras que está presente.

Problema	Causa provável	Soluções possíveis
	O código de barras não é legível.	Verifique se o código não está apagado. Experimente ler códigos de teste do mesmo tipo do código de barras.
	A distância entre o scanner e o código de barras não está correta.	Aproxime ou afaste o scanner do código de barras.
O código é decodificado, mas não é transmitido para o host.	O scanner não está programado para o tipo correto de host.	Leia o código de barras do tipo correto de host.
Os dados lidos são exibidos incorretamente no host.	O scanner não está programado para operar com o host. Verifique os parâmetros ou as opções de edição dos hosts.	<p>Verifique se o host correto está selecionado.</p> <p>Para RS-232, verifique se os parâmetros de comunicação do scanner correspondem às configurações do host.</p> <p>Para uma configuração do tipo acoplado ao teclado, verifique se o sistema está programado para o tipo correto de teclado, e se a tecla CAPS LOCK está desativada.</p> <p>Verifique se as opções de edição (por exemplo, conversão de UPC-E para UPC-A) estão programadas corretamente.</p>

ク イ ッ ク リ フ ァ レ ン ス

はじめに

画期的で、高度なパフォーマンスのスキャン・ソリューションを長年提供してきた Symbol が、その経験の成果としてお送りするのが LS4008i です。LS4008i は、お求めやすい価格で、優れたスキャン性能と 5 年間の製品保証を提供します。

LS4008i シリーズ スキャナの各部

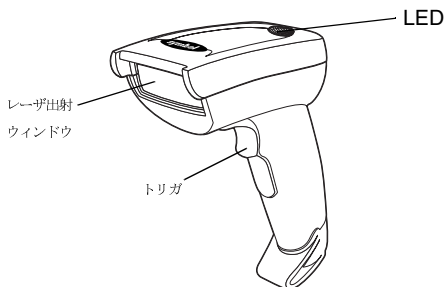

インタフェース ケーブルを接続する

1. インタフェース ケーブル モジュラコネクタを LS4008i シリーズのスキャナハンドルの底部にあるケーブル インタフェース ポートに接続します。

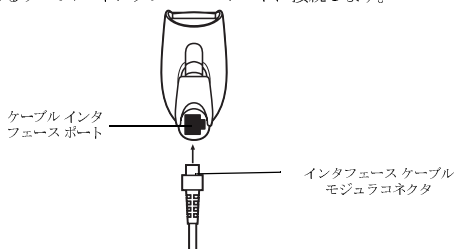

2. インタフェース ケーブルのもう一端をホストに接続します。
3. 外部電源を使用する場合は、電源をケーブルに接続します。
4. 37 ページから、ホストと通信するための適切なバーコードをスキャンします。

インタフェース ケーブルを取り外す

ドライバーの先端でコネクタ クリップを押し込み、接続したケーブルのモジュラコネクタを外します。

読取り操作上の注意

注： スキャナをバーコード面に対して直角に向けてスキャンしないでください。

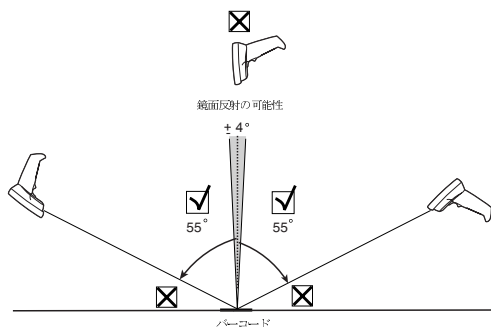

ハンドヘルドモードでのスキャン

1. ケーブルなどがすべて確実に接続されていることを確認します
2. スキャナをバーコードに向けます（トリガが付いている場合、スキャナを向けトリガを引きます）。
3. スキャンラインがバーコード全体を横切るようにスキャンします。

正しい操作



間違った操作



4. 正しくデコードできた場合は、スキャナからピープ音が鳴り、LED が緑に変わります。

ク イ ッ ク リ フ ァ レ ン ス

ハンドフリーモードでのスキャン

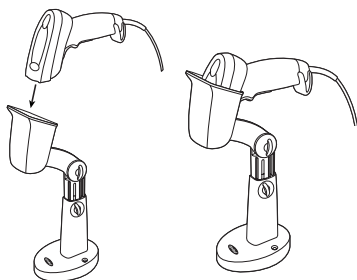

スタンド上では、スキャナは常時オン状態です。スタンドから外すと、スキャナは通常のハンドヘルドモードになります(モデルによって、常時オンモードとトリガモードなどがあります)。

1. スキャナをスタンドに装着します。
2. スキャンラインがバーコード全体を横切るように、バーコードラベルをかざします。
3. 正しくデコードできた場合は、スキャナからピープ音が鳴り、LED が緑に変わります。

トラブルシューティング

現象	考えられる原因	措置
操作手順に従っても、全く反応を示さない。	スキャナの電源が入っていません。	システムの電源を確認してください。電源が必要な構成の場合は、電源が正しく接続されていることを確認します。
	インターフェイス / 電源ケーブルの接続が不完全です。	ケーブルがゆるんでいないか確認してください。
レーザーは出射されているが、バーコードを読み取らない。	読み取るバーコードの種類が正しく設定されていません。	スキャンするバーコードを読み取るようにスキャナを設定してください。



現象	考えられる原因	措置
	バーコードの状態に問題があります。	バーコードに傷、汚れなどによるダメージがないかどうか確認します。同じバーコードタイプのテストシンボルをスキャンしてみてください。
	スキャナとバーコード間の距離が適切ではありません。	バーコードの大きさに合わせてスキャナを近づけたり、遠ざけたりしてください。
読み取ったバーコードデータがホストに転送されない。	スキャナが、接続するホストタイプ用に正しく設定されていません。	適切なホストタイプバーコードをスキャンしてください。
スキャンしたバーコードデータが正しくホストに転送されない。	スキャナが、接続するホスト用に設定されていません。スキャナのホストタイプパラメータおよび編集オプションを確認してください。	正しいホストが選択されていることを確認してください。 RS-232 の場合、スキャナの通信パラメータがホストの設定と一致している必要があります。 Keyboard Wedge 構成では、システムが正しいキーボードタイプに設定され、CAPS LOCK キーがオフになっていなければなりません。 編集オプション (UPC-E/UPC-A 変換など) を正しく設定してください。

简介

LS 4008i 是 Symbol 公司极具创新性和高性能扫描解决方案的卓越代表。LS 4008i 带给用户完美的条形码扫描性能和最大程度的舒适感。此外，合理的价格以及五年的超长保修也是这款产品令人心动之处。

注：除非另有说明，LS190xx 指所有型号的扫描器。

LS4008i 系列扫描器部件



安装接口电缆

1. 将接口电缆方型连接器插入扫描器柄底部的电缆接口端口。

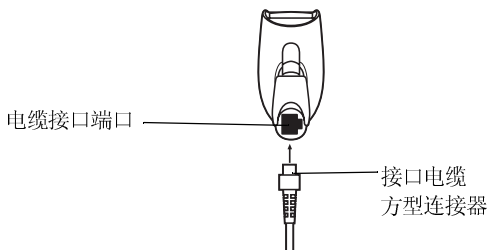

2. 将接口电缆的另一端连接到主机。
3. 将电缆接至电源 (如有必要)。
4. 从第 37 页开始对相应条码进行扫描，以与主机通讯。

拔出接口电缆

用螺丝刀头按住连接器夹子，拔出已插入的电缆方型连接器。

瞄准

注：扫描器与条码不完全垂直时效果最佳。

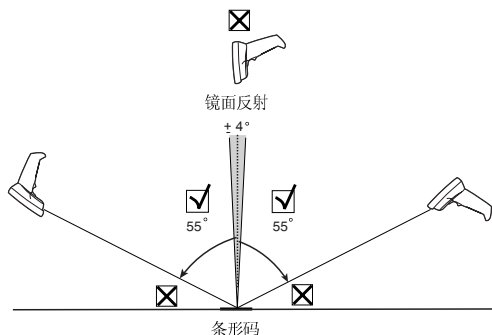

以手持模式扫描

1. 请确保所有连接的牢固。
2. 将扫描器对准条码。（如果扫描器有触发开关，则将扫描器对准条码，然后按下触发开关）。
3. 请确保扫描线扫过符号的所有条形及空格。

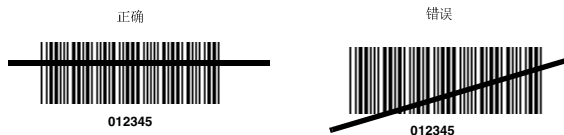

4. 成功解码后，扫描器会发出蜂鸣声且发光管发出绿光。

以放手模式扫描

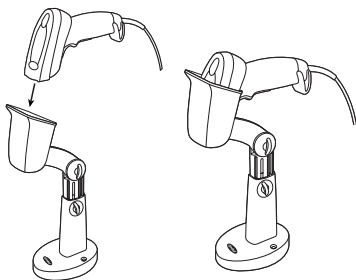

当置于支架上时，扫描器处于固定模式。若将扫描器从支架上移开，它将以正常的手持模式运行（例如，固定模式或触发开关模式，视型号而定）。

1. 将扫描器放入支架。
2. 瞄准条码，确保扫描线扫过符号的所有条形及空格。
3. 成功解码后，扫描器会发出蜂鸣声且发光管发出绿光。

故障解决

问题	可能原因	可能的解决办法
如果遵循操作说明，不会发生问题。	扫描器未接通电源。	检查系统电源。如果扫描器配置需要电源，则应确保已连接完毕。
	接口 / 电源电缆松动。	检查电缆连接是否松动。
激光出现但符号未解码。	没有将扫描器编程为适用于该条码类型的程序。	确保已将扫描器编程为能够读取待扫描条码类型。
	条码符号不可读。	检查符号以确保其未受损伤。试着扫描相同条码类型的测试符号。
	扫描器与条码的距离不合适。	将扫描器从条码移近或移远。

问题	可能原因	可能的解决办法
符号解码完成，但未传至主机。	没有将扫描器编程为适用于该主机类型的程序。	扫描相应的主机类型条码。
扫描数据在主机上显示有误。	没有将扫描器编程为能与主机协同工作的程序。检查 S1900 系列主机类型参数或编辑选项。	<p>请确保选择了正确的主机。</p> <p>对于 RS-232，应确保扫描器的通讯参数与主机设置相匹配。</p> <p>对于键盘仿真配置，应确保为系统编制了适用于键盘类型的程序，并且 CAPS LOCK 键处于关闭状态。</p> <p>确保为编辑选项(例如，从 UPC-E 到 UPC-A 的转换)正确编制了程序。</p>

소개

LS4008i 는 스캐닝 솔루션 설계에 관한 Symbol 의 오랜 경험의 산물로서 , 혁신적인 고성능 스캔 성능을 자랑합니다 . LS4008i 는 바코드 스캔 성능이 우수하며 사용자 편의를 최대화하였습니다 . 그리고 , 5 년 추가 보증을 포함한 효율적인 가격으로 소비자를 만족시켜 드립니다 .

LS4008i 시리즈 스캐너의 부품

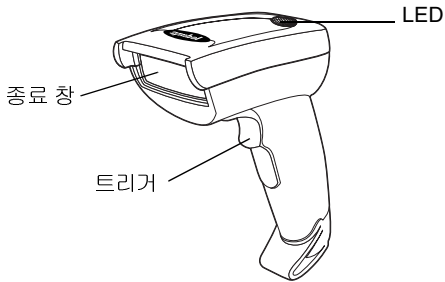

인터페이스 케이블 설치하기

1. 인터페이스 케이블 모듈 커넥터를 스캐너 손잡이 바닥에 있는 케이블 인터페이스 포트에 꽂습니다

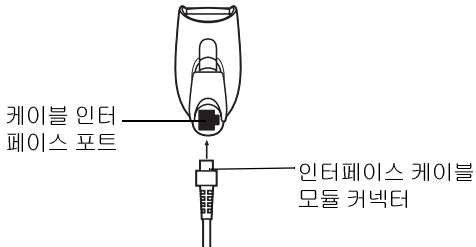

2. 인터페이스 케이블의 다른 끝을 호스트에 연결합니다 .
3. 전원 공급 장치를 케이블에 연결합니다 (필요한 경우) .
4. 37 쪽에 있는 대로 적절한 바코드를 스캔하여 호스트와 통신합니다 .

인터페이스 케이블 제거하기

스크루 드라이버 끝으로 커넥터 고정핀을 눌러 설치된 케이블의 모듈 커넥터를 뺍니다.

조준

주: 스캐너는 바코드에 완전히 수직으로 조준하지 않아야 잘 작동됩니다.

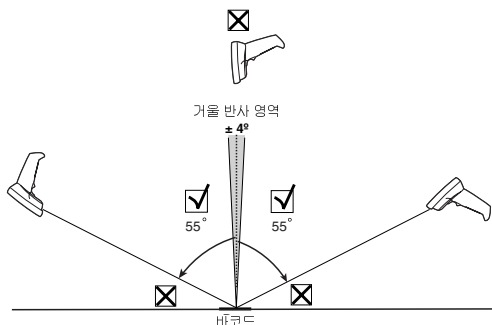

휴대용 모드에서 스캔하기

1. 모든 연결 부분이 단단히 고정되어 있는지 확인합니다.
2. 스캐너를 바코드에 조준합니다. (스캐너에 트리거가 있는 경우 스캐너를 조준하고 트리거를 누릅니다.)
3. 스캔 라인이 심볼의 모든 막대와 여백을 통과하도록 스캔합니다.



4. 바코드 해독에 성공하게 되면, 스캐너는 경고음을 울리고 LED는 녹색이 됩니다.

핸즈 - 프리 모드에서 스캔하기

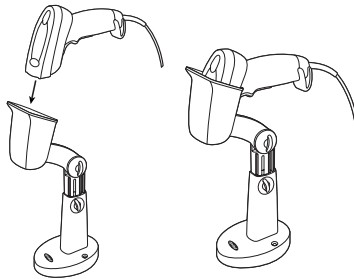

스탠드에 있는 스캐너는 항상 켜짐 모드 상태입니다. 스탠드에서 스캐너를 제거하면 일반 휴대용 모드 (즉 , 모델에 따라 항상 켜짐 모드나 트리거 모드) 에서 작동합니다 .

1. 스캐너를 스탠드에 끼웁니다 .
2. 바코드를 준비하고 스캔 라인이 심볼의 모든 막대와 여백을 통과하도록 스캔합니다 .
3. 바코드 해독에 성공하면 스캐너는 경고음을 울리고 LED 는 녹색이 됩니다 .

문제 해결

문제	가능한 원인	가능한 해결 방안
작동 방법을 따라 해도 아무런 일이 일어나지 않습니다 .	스캐너 전원이 켜져 있지 않습니다 .	시스템 전원을 확인하십시오 . 전원 공급장치가 필요한 구성조건인 경우 전원 공급장치가 연결되어 있는지 확인하십시오 .
	인터페이스 / 전원 케이블이 느슨합니다 .	느슨한 케이블 연결부를 확인하십시오 .

문제	가능한 원인	가능한 해결 방안
레이저는 켜져 있지만 바코드 심볼을 해독하지 못합니다.	스캐너가 해당 바코드 형식에 맞지 않게 프로그램되어 있습니다.	스캐너가 스캔 중인 바코드 형식에 맞게 프로그램되어 있어야 합니다.
	바코드 심볼을 읽을 수 없습니다.	바코드 심볼의 표면이 손상되지 않았는지 확인하십시오. 동일한 형식의 바코드 심볼을 스캔해 보십시오.
	스캐너와 바코드 사이의 거리가 올바르지 않습니다.	스캐너를 바코드에 가까이 또는 멀리 움직여 보십시오.
바코드 심볼은 해독되었지만 호스트로 전송되지 않습니다.	스캐너가 해당 호스트 종류에 맞게 프로그램되어 있지 않습니다.	적절한 호스트 형식의 바코드를 스캔하십시오.
스캔한 데이터가 호스트에 올바르게 표시되지 않습니다.	스캐너가 호스트와 작동하도록 프로그램되어 있지 않습니다. 시리즈의 호스트 종류 매개변수 또는 편집 옵션을 확인하십시오.	적절한 호스트가 선택되었는지 확인하십시오. RS-232 의 경우 스캐너의 통신 매개변수가 호스트의 설정과 일치하는지 확인하십시오. 키보드 웨지 구성의 경우 시스템이 올바른 키보드 종류로 프로그램되었는지, 그리고 Caps Lock 키가 꺼져 있는지 확인하십시오. 편집 옵션 (예: UPC-E 에서 UPC-A 로의 변환) 이 적절히 프로그램되었는지 확인하십시오.

Programming Bar Codes

Following are some frequently used programming bar codes.

Note: For additional host types, refer to the *LS4008i Series Product Reference Guide*, p/n 72-53911-xx, available on the LS4008i Series CD.

Set Defaults

Scanning this bar code sets all parameters to their default values.



Host Type

If you are using a Synapse cable (i.e., part number ST1xx-xxxx), the scanner autodetects the type of host you are using, so you do not need to scan bar codes.

If you are using a USB interface, the scanner autodetects the USB and defaults to the HID keyboard interface. See below to select the IBM Hand-Held host type. Refer to the *LS 4008i Product Reference Guide*, p/n 72-53911-xx, for additional USB host types. If you are using Keyboard Wedge, RS-232, Wand Emulation, or IBM 46XX, you must select that host type from the following bar codes:

Keyboard Wedge Host Type



Country Keyboard Types



NORTH AMERICAN



FRENCH



FRENCH CANADIAN



GERMAN



SPANISH



ITALIAN



SWEDISH

Q u i c k R e f e r e n c e

Country Keyboard Types



JAPANESE



UK ENGLISH

RS-232 Host Types



STANDARD RS-232C



ICL RS-232C



NIXDORF RS-232C MODE A



NIXDORF RS-232C MODE B



FUJITSU RS-232C



OPOS

USB Host Types



HID KEYBOARD EMULATION
(Common Keyboard Wedge Interfacing)



IBM HAND-HELD USB
(For IBM SurePOS 700 Series)

IBM 46XX Host Types



PORT 9B



PORT 5B



PORT 17

Wand Host Type



SYMBOL WAND

Carriage Return/Line Feed

To append a carriage return/line feed to all transmitted data, scan the following bar codes in the order shown. To cancel this operation, scan the “Set Defaults” bar code on page 37, or refer to the *LS 4008i Series Product Reference Guide*.



SCAN OPTIONS



<DATA><SUFFIX>



ENTER

Regulatory Information

All Symbol devices are designed to be compliant with rules and regulations in locations they are sold and will be labeled as required.

Any changes or modifications to Symbol Technologies equipment, not expressly approved by Symbol Technologies, could void the user's authority to operate the equipment.

Ergonomic Recommendations

Caution: In order to avoid or minimize the potential risk of ergonomic injury follow the recommendations below. Consult with your local Health & Safety Manager to ensure that you are adhering to your company's safety programs to prevent employee injury.

- Reduce or eliminate repetitive motion
- Maintain a natural position
- Reduce or eliminate excessive force
- Keep objects that are used frequently within easy reach
- Perform tasks at correct heights
- Reduce or eliminate vibration
- Reduce or eliminate direct pressure
- Provide adjustable workstations
- Provide adequate clearance
- Provide a suitable working environment
- Improve work procedures.

Power Supply

Note: Use only a Symbol-approved power supply with output rated 5.2Vdc and minimum 650mA. The power supply is certified to EN60950 with SELV outputs.

Hinweis: Benutzen Sie nur eine Symbol Technologies genehmigt Stromversorgung in den Ausgabe: 5.2Vdc und minimum 650mA. Die Stromversorgung ist bescheinigt nach EN60950 mit SELV Ausgaben



Radio Frequency Interference Requirements

Note: This equipment has been tested and found to comply with the limits for a Class B digital device, pursuant to Part 15 of the FCC rules. These limits are designed to provide reasonable protection against harmful interference in a residential installation. This equipment generates, uses, and can radiate radio frequency energy and, if not installed and used in accordance with the instructions, may cause harmful interference to radio communications. However there is no guarantee that interference will not occur in a particular installation. If this equipment does cause harmful interference to radio or television reception, which can be determined by turning the equipment off and on, the user is encouraged to try to correct the interference by one or more of the following measures:

- Reorient or relocate the receiving antenna
- Increase the separation between the equipment and receiver

Q u i c k R e f e r e n c e

- Connect the equipment into an outlet on a circuit different from that to which the receiver is connected
- Consult the dealer or an experienced radio/TV technician for help.

Radio Frequency Interference Requirements - Canada

This Class B digital apparatus complies with Canadian ICES-003.

Cet appareil numérique de la classe B est conforme à la norme NMB-003 du Canada.

Marking and European Economic Area (EEA)

Statement of Compliance



Symbol Technologies, Inc., hereby declares that this device is in compliance with all the applicable Directives, 89/336/EEC, 73/23/EEC. A Declaration of Conformity may be obtained from <http://www2.symbol.com/doc/>

www2.symbol.com/doc/

Laser Devices



Symbol devices using lasers comply with US 21CFR1040.10, and IEC825-1:1993, EN60825-1:1994+A11:1996. The laser classification is marked on one of the labels on the device.

Class 1 Laser devices are not considered to be hazardous when used for their intended purpose. The following statement is required to comply with US and international regulations:

Caution: Use of controls, adjustments or performance of procedures other than those specified herein may result in hazardous laser light exposure.

Class 2 laser scanners use a low power, visible light diode. As with any very bright light source, such as the sun, the user should avoid staring directly into the light beam. Momentary exposure to a Class 2 laser is not known to be harmful.

Scanner Labeling



In accordance with Clause 5, IEC 825 and EN60825, the following information is provided to the user:



ENGLISH

CLASS 1 LASER PRODUCT
LASER LIGHT
DO NOT STARE INTO BEAM
CLASS 2 LASER PRODUCT

HEBREW

מוצר לייזר רמה 1 1 רמה
אור לייזר 2 רמה
אין להביט אל תוך הזרם
מוצר לייזר רמה 2

DANISH / DANSK

KLASSE 1 KLASSE 1 LASERPRODUKT
KLASSE 2 LASERLYF
SE IKKE IND I STRÅLEN
KLASSE 2 LASERPRODUKT

ITALIAN / ITALIANO

CLASSE 1 PRODOTTO AL LASER DI CLASSE 1
CLASSE 2 LUCE LASER
NON FISSARE IL RAGGIOPRODOTTO
AL LASER DI CLASSE 2

DUTCH / NEDERLANDS

KLASSE 1 KLASSE 1 LASERPRODUKT
KLASSE 2 LASERLICHT
NIET IN STRAAL STAREN
KLASSE 2 LASERPRODUKT

NORWEGIAN / NORSK

KLASSE 1 LASERPRODUKT, KLASSE 1
KLASSE 2 LASERLYS IKKE STIRR INN I LYSSTRÅLEN
LASERPRODUKT, KLASSE 2

FINNISH / SUOMI

LUOKKA 1 LUOKKA 1 LASERTUOTE
LUOKKA 2 LASERVALO
ÄLÄ TUUJOTA SÄDETTÄ
LUOKKA 2 LASERTUOTE

PORTUGUESE / PORTUGUÊS

CLASSE 1 PRODUTO LASER DA CLASSE 1
CLASSE 2 LUZ DE LASER NÃO FIXAR O RAIO LUMINOSO
PRODUTO LASER DA CLASSE 2

FRENCH / FRANÇAIS

CLASSE 1 PRODUIT LASER DE CLASSE 1
CLASSE 2 LUMIERE LASER
NE PAS REGARDER LE RAYON FIXEMENT
PRODUIT LASER DE CLASSE 2

SPANISH / ESPAÑOL

CLASE 1 PRODUCTO LASER DE LA CLASE 1
CLASE 2 LUZ LASER
NO MIRE FIJAMENTE EL HAZ
PRODUCTO LASER DE LA CLASE 2

GERMAN / DEUTCH

KLASSE 1 LASERPRODUKT DER KLASSE 1
KLASSE 2 LASERSTRAHLEN
NICHT DIREKT IN DEN LASERSTRAHL SCHAUEN
LASERPRODUKT DER KLASSE 2

SWEDISH / SVENSKA

KLASS 1 LASERPRODUKT KLASS 1
KLASS 2 LASERLJUS STIRRA INTE MOT STRÅLEN
LASERPRODUKT KLASS 2

Warranty

Symbol Technologies, Inc (“Symbol”) manufactures its hardware products in accordance with industry-standard practices. Symbol warrants that products will be free from defects in materials and workmanship for a period of sixty months (60 months) from date of shipment and for the life of the product with regard to the Mylar Scan Element (consisting of a Mylar Strip, mirror assembly and magnet) embedded in the products.

This warranty is provided to the original owner only and is not transferable to any third party. It shall not apply to any product (i) which has been repaired or altered unless done or approved by Symbol, (ii) which has not been maintained in accordance with any operating or handling instructions supplied by Symbol, (iii) which has been subjected to unusual physical or electrical stress, misuse, abuse, power shortage, negligence or accident or (iv) which has been used other than in accordance with the product operating and handling instructions. Preventive maintenance is the responsibility of customer and is not covered under this warranty.

Q u i c k R e f e r e n c e

Wear items and accessories having a Symbol serial number, will carry a 90-day limited warranty. Non-serialized items will carry a 30-day limited warranty.

Warranty Coverage and Procedure

During the warranty period, Symbol will repair or replace defective products returned to Symbol's manufacturing plant in the US. For warranty service in North America, call the Symbol Support Center at 1-800-653-5350. International customers should contact the local Symbol office or support center. If warranty service is required, Symbol will issue a Return Material Authorization Number. Products must be shipped in the original or comparable packaging, shipping and insurance charges prepaid. Symbol will ship the repaired or replacement product freight and insurance prepaid in North America. Shipments from the US or other locations will be made F.O.B. Symbol's manufacturing plant.

Symbol will use new or refurbished parts at its discretion and will own all parts removed from repaired products. Customer will pay for the replacement product in case it does not return the replaced product to Symbol within 3 days of receipt of the replacement product. The process for return and customer's charges will be in accordance with Symbol's Exchange Policy in effect at the time of the exchange. Customer accepts full responsibility for its software and data including the appropriate backup thereof.

Repair or replacement of a product during warranty will not extend the original warranty term.

Symbol's Customer Service organization offers an array of service plans, such as on-site, depot, or phone support, that can be implemented to meet customer's special operational requirements and are available at a substantial discount during warranty period.

General

Except for the warranties stated above, Symbol disclaims all warranties, express or implied, on products furnished hereunder, including without limitation implied warranties of merchantability and fitness for a particular purpose. The stated express warranties are in lieu of all obligations or liabilities on part of Symbol for damages, including without limitation, special, indirect, or consequential damages arising out of or in connection with the use or performance of the product.

Seller's liability for damages to buyer or others resulting from the use of any product, shall in no way exceed the purchase price of said product, except in instances of injury to persons or property.

Some states (or jurisdictions) do not allow the exclusion or limitation of incidental or consequential damages, so the proceeding exclusion or limitation may not apply to you.

Service Information

Before you use the unit, it must be configured to operate in your facility's network and run your applications.

If you have a problem running your unit or using your equipment, contact your facility's Technical or Systems Support. If there is a problem with the equipment, they will contact the Symbol Support Center:

United States ¹	1-800-653-5350 1-631-738-2400	Canada	905-629-7226
United Kingdom	0800 328 2424	Asia/Pacific	337-6588
Australia	1-800-672-906	Austria/Österreich	1-505-5794-0
Denmark/Danmark	7020-1718	Finland/Suomi	9 5407 580
France	01-40-96-52-21	Germany/Deutschland	6074-49020
Italy/Italia	2-484441	Mexico/México	5-520-1835
Netherlands/Nederland	315-271700	Norway/Norge	+47 2232 4375
South Africa	11-8095311	Spain/España	91 324 40 00 Inside Spain
Sweden/Sverige	84452900		+34 91 324 40 00 Outside Spain
Latin America Sales Support	1-800-347-0178 Inside US +1-561-483-1275 Outside US		
Europe/Mid-East Distributor Operations	Contact local distributor or call +44 118 945 7360		

¹Customer support is available 24 hours a day, 7 days a week.

For the latest version of this guide go to:<http://www.symbol.com/manuals>.

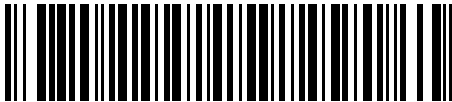

72-55348-01
Revision A— May 2002