

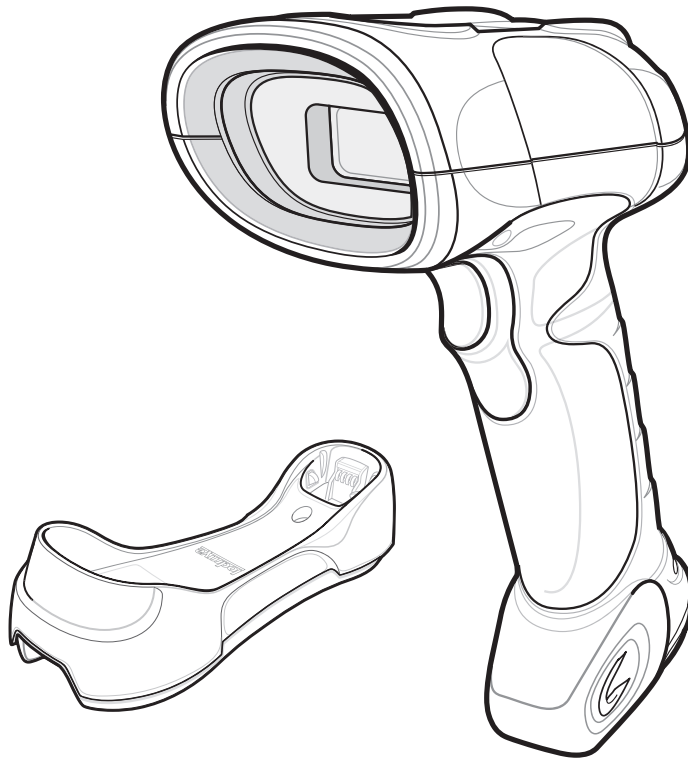

# Symbol DS3478

## Product Reference Guide





***Symbol DS3478 Smart Focus Digital Scanner  
Product Reference Guide***

*72E-72109-05*

*Revision A*

*May 2009*

© 2009 by Motorola, Inc. All rights reserved.

No part of this publication may be reproduced or used in any form, or by any electrical or mechanical means, without permission in writing from Motorola. This includes electronic or mechanical means, such as photocopying, recording, or information storage and retrieval systems. The material in this manual is subject to change without notice.

The software is provided strictly on an “as is” basis. All software, including firmware, furnished to the user is on a licensed basis. Motorola grants to the user a non-transferable and non-exclusive license to use each software or firmware program delivered hereunder (licensed program). Except as noted below, such license may not be assigned, sublicensed, or otherwise transferred by the user without prior written consent of Motorola. No right to copy a licensed program in whole or in part is granted, except as permitted under copyright law. The user shall not modify, merge, or incorporate any form or portion of a licensed program with other program material, create a derivative work from a licensed program, or use a licensed program in a network without written permission from Motorola. The user agrees to maintain Motorola’s copyright notice on the licensed programs delivered hereunder, and to include the same on any authorized copies it makes, in whole or in part. The user agrees not to decompile, disassemble, decode, or reverse engineer any licensed program delivered to the user or any portion thereof.

Motorola reserves the right to make changes to any software or product to improve reliability, function, or design.

Motorola does not assume any product liability arising out of, or in connection with, the application or use of any product, circuit, or application described herein.

No license is granted, either expressly or by implication, estoppel, or otherwise under any Motorola, Inc., intellectual property rights. An implied license only exists for equipment, circuits, and subsystems contained in Motorola products.

MOTOROLA and the Stylized M Logo and Symbol and the Symbol logo are registered in the US Patent & Trademark Office. Bluetooth is a registered trademark of Bluetooth SIG. Microsoft, Windows and ActiveSync are either registered trademarks or trademarks of Microsoft Corporation. All other product or service names are the property of their respective owners.

Motorola, Inc.  
One Motorola Plaza  
Holtsville, New York 11742-1300  
<http://www.motorola.com/enterprisemobility>

---

## Patents

This product is covered by one or more of the patents listed on the website:  
<http://www.motorola.com/enterprisemobility/patents>



## Revision History

Changes to the original manual are listed below:

Change	Date	Description
-01 Rev A	6/2005	Initial release.
-02 Rev A	2/2007	Update service information; correct Symbol PTC Terminal bar code; specify that Multipoint mode does not support Beep on <BEL> feature.
-03 Rev A	7/2007	Add DPM version information, including new decode zones and DPM Scanning parameter; added picklist mode, new UPC/EAN Supplemental options, Bookland ISBN format, 4State Postal, Inverse 1D, Data Matrix Inverse, Micro QR, QR Inverse, Aztec, Aztec Inverse parameters.
-04 Rev A	8/2008	Add 2D decode zones, add Decode Mirror Images parameter, removed IBM XT bar code and keyboard from Keyboard Wedge section, add Code 128 Lengths and Post US4 options, change UCC/EAN-128 code type name to GS1-128.
-05 Rev A	5/2009	Add ISSN EAN, Matrix 2 of 5, and Chinese 2 of 5 code types; add ISBT concatenation parameters; change Dutch Postal references to Netherlands KIX Code, 4State Postal to USPS 4CB/One Code/Intelligent Mail, and Post US4 to UPU FICS Postal.



# Table of Contents

## About This Guide

Introduction .....	xv
Configurations .....	xv
Chapter Descriptions .....	xv
Notational Conventions .....	xvi
Related Publications .....	xvii
Service Information .....	xvii

## Chapter 1: Getting Started

Introduction .....	1-1
Smart Focus Scanning .....	1-1
Host Interfaces .....	1-2
Unpacking the Digital Scanner .....	1-2
The Digital Scanner Cradle .....	1-2
Cradle Parts .....	1-3
Connecting the Cradle .....	1-4
Supplying Power to the Cradle .....	1-5
Connecting a Synapse Cable Interface .....	1-6
Reestablishing a Lost Connection to Host .....	1-6
Mounting the Cradle .....	1-6
Removing and Inserting the Battery .....	1-7
Charging the Battery .....	1-8
Charging LED .....	1-8
Charging Problem LED .....	1-8
Inserting the Digital Scanner in the Cradle .....	1-9
Pairing .....	1-9
Unpairing .....	1-10
Configuring the Digital Scanner .....	1-10

## Chapter 2: Digital Scanning

Introduction .....	2-1
Beeper Definitions .....	2-2

LED Definitions .....	2-5
Digital Scanning .....	2-6
Aiming .....	2-7
Decode Zones .....	2-8
DS3478-SF Near Focus - 1D and PDF417 .....	2-8
DS3478-SF Near Focus - 2D Codes .....	2-9
DS3478-SF Far Focus .....	2-10
DS3478-SF Smart Focus .....	2-11
DS3478-HD/DPM Near Focus - 1D and PDF417 .....	2-12
DS3478-HD/DPM Near Focus - 2D Codes .....	2-13
DS3478-HD/DPM Far Focus .....	2-14
DS3478-HD/DMP Smart Focus .....	2-15

### Chapter 3: Maintenance and Technical Specifications

Introduction .....	3-1
Maintenance .....	3-1
Troubleshooting .....	3-2
Technical Specifications .....	3-5
Digital Scanner Signal Descriptions .....	3-7

### Chapter 4: User Preferences

Introduction .....	4-1
Scanning Sequence Examples .....	4-2
Errors While Scanning .....	4-2
User Preferences Default Parameters .....	4-2
User Preferences .....	4-3
Set Default Parameter .....	4-3
Parameter Scanning .....	4-3
Beeper Tone .....	4-4
Beeper Volume .....	4-5
Power Mode .....	4-5
Beep After Good Decode .....	4-6
Picklist Mode .....	4-7
Decode Session Timeout .....	4-8
Fuzzy 1D Decoding .....	4-8
Decode Mirror Images (Data Matrix Only) .....	4-9
Radio Communications .....	4-10
Connection Maintenance Interval .....	4-10
Radio Output Power .....	4-12
Parameter Broadcast .....	4-12
Single Point/Multipoint Operation .....	4-13

### Chapter 5: Decoding Preferences

Introduction .....	5-1
Scanning Sequence Examples .....	5-2
Errors While Scanning .....	5-2
Decoding Preferences Parameter Defaults .....	5-2

Decoding Preferences .....	5-3
Focus Mode .....	5-3
Decoding Illumination .....	5-4
Decode Aiming Pattern .....	5-4
DPM Scanning .....	5-5
<b>Chapter 6: Keyboard Wedge Interface</b>	
Introduction .....	6-1
Connecting a Keyboard Wedge Interface .....	6-2
Keyboard Wedge Default Parameters .....	6-3
Keyboard Wedge Parameters .....	6-4
Keyboard Wedge Host Types .....	6-4
Keyboard Wedge Country Types (Country Codes) .....	6-5
Ignore Unknown Characters .....	6-7
Keystroke Delay .....	6-7
Intra-Keystroke Delay .....	6-8
Alternate Numeric Keypad Emulation .....	6-8
Caps Lock On .....	6-9
Caps Lock Override .....	6-9
Convert Wedge Data .....	6-10
Function Key Mapping .....	6-10
FN1 Substitution .....	6-11
Send Make and Break .....	6-11
Keyboard Maps .....	6-12
ASCII Character Set .....	6-14
<b>Chapter 7: RS-232 Interface</b>	
Introduction .....	7-1
Connecting an RS-232 Interface .....	7-2
RS-232 Default Parameters .....	7-3
RS-232 Host Parameters .....	7-4
RS-232 Host Types .....	7-6
Baud Rate .....	7-7
Parity .....	7-9
Check Receive Errors .....	7-10
Stop Bit Select .....	7-10
Data Bits .....	7-11
Hardware Handshaking .....	7-11
Software Handshaking .....	7-13
Host Serial Response Time-out .....	7-15
RTS Line State .....	7-16
Beep on <BEL> .....	7-16
Intercharacter Delay .....	7-17
Nixdorf Mode A/B and OPOS/JPOS Beep/LED Options .....	7-18
Ignore Unknown Characters .....	7-19
ASCII Character Set .....	7-20

**Chapter 8: USB Interface**

Introduction .....	8-1
USB Default Parameters .....	8-3
USB Host Parameters .....	8-4
USB Device Type .....	8-4
USB Country Keyboard Types (Country Codes) .....	8-5
USB Keystroke Delay .....	8-7
USB Caps Lock Override .....	8-7
USB Ignore Unknown Characters .....	8-8
Emulate Keypad .....	8-8
USB Keyboard FN1 Substitution .....	8-9
Function Key Mapping .....	8-9
Simulated Caps Lock .....	8-10
Convert Case .....	8-10
ASCII Character Set .....	8-11

**Chapter 9: IBM 468X/469X Interface**

Introduction .....	9-1
Connecting to an IBM 468X/469X Host .....	9-2
IBM Default Parameters .....	9-3
IBM 468X/469X Host Parameters .....	9-4
Port Address .....	9-4
Convert Unknown to Code 39 .....	9-5

**Chapter 10: Wand Emulation Interface**

Introduction .....	10-1
Connecting a Wand Emulation Interface .....	10-2
Wand Emulation Default Parameters .....	10-3
Wand Emulation Host Parameters .....	10-4
Wand Emulation Host Types .....	10-4
Leading Margin (Quiet Zone) .....	10-5
Polarity .....	10-6
Ignore Unknown Characters .....	10-6
Convert All to Code 39 .....	10-7
Convert Code 39 to Full ASCII .....	10-8

**Chapter 11: Scanner Emulation Interface**

Introduction .....	11-1
Connecting Using Scanner Emulation .....	11-2
Scanner Emulation Default Parameters .....	11-3
Scanner Emulation Host Parameters .....	11-4
Scanner Emulation Host .....	11-4
Beep Style .....	11-4
Parameter Pass-Through .....	11-5
Convert Newer Code Types .....	11-6
Module Width .....	11-7
Convert All Bar Codes to Code 39 .....	11-7

Code 39 Full ASCII Conversion .....	11-8
Transmission Timeout .....	11-9
Ignore Unknown Characters .....	11-10
Leading Margin .....	11-11
Check for Decode LED .....	11-12
<b>Chapter 12: 123Scan</b>	
Introduction .....	12-1
Setting Up 123Scan .....	12-1
<b>Chapter 13: Symbolologies</b>	
Introduction .....	13-1
Scanning Sequence Examples .....	13-1
Errors While Scanning .....	13-1
Symbology Default Parameters .....	13-2
UPC/EAN .....	13-7
Enable/Disable UPC-A .....	13-7
Enable/Disable UPC-E .....	13-7
Enable/Disable UPC-E1 .....	13-8
Enable/Disable EAN-13 .....	13-8
Enable/Disable EAN-8 .....	13-9
Enable/Disable Bookland EAN .....	13-9
Decode UPC/EAN Supplementals .....	13-10
User-Programmable Supplementals .....	13-13
UPC/EAN Supplemental Redundancy .....	13-13
Transmit UPC-A/UPC-E/UPC-E1 Check Digit .....	13-14
UPC-A Preamble .....	13-16
UPC-E Preamble .....	13-17
UPC-E1 Preamble .....	13-18
Convert UPC-E to UPC-A .....	13-19
Convert UPC-E1 to UPC-A .....	13-19
EAN-8 Extend .....	13-20
Bookland ISBN Format .....	13-21
UCC Coupon Extended Code .....	13-22
ISSN EAN .....	13-22
Code 128 .....	13-23
Enable/Disable Code 128 .....	13-23
Set Lengths for Code 128 .....	13-23
Enable/Disable GS1-128 (formerly UCC/EAN-128) .....	13-25
Enable/Disable ISBT 128 .....	13-25
ISBT Concatenation .....	13-26
Check ISBT Table .....	13-27
ISBT Concatenation Redundancy .....	13-27
Code 39 .....	13-28
Enable/Disable Code 39 .....	13-28
Enable/Disable Trioptic Code 39 .....	13-28
Convert Code 39 to Code 32 .....	13-29
Code 32 Prefix .....	13-29

Set Lengths for Code 39 .....	13-30
Code 39 Check Digit Verification .....	13-32
Transmit Code 39 Check Digit .....	13-32
Code 39 Full ASCII Conversion .....	13-33
Code 39 Buffering (Scan & Store) .....	13-34
Code 93 .....	13-36
Enable/Disable Code 93 .....	13-36
Set Lengths for Code 93 .....	13-36
Code 11 .....	13-38
Code 11 .....	13-38
Set Lengths for Code 11 .....	13-38
Code 11 Check Digit Verification .....	13-40
Transmit Code 11 Check Digits .....	13-41
Interleaved 2 of 5 (I 2 of 5) .....	13-42
Enable/Disable Interleaved 2 of 5 .....	13-42
Set Lengths for Interleaved 2 of 5 .....	13-42
I 2 of 5 Check Digit Verification .....	13-44
Transmit I 2 of 5 Check Digit .....	13-44
Convert I 2 of 5 to EAN-13 .....	13-45
Discrete 2 of 5 (D 2 of 5) .....	13-46
Enable/Disable Discrete 2 of 5 .....	13-46
Set Lengths for Discrete 2 of 5 .....	13-46
Codabar (NW - 7) .....	13-48
Enable/Disable Codabar .....	13-48
Set Lengths for Codabar .....	13-48
CLSI Editing .....	13-50
NOTIS Editing .....	13-50
MSI .....	13-51
Enable/Disable MSI .....	13-51
Set Lengths for MSI .....	13-51
MSI Check Digits .....	13-53
Transmit MSI Check Digit(s) .....	13-53
MSI Check Digit Algorithm .....	13-54
Chinese 2 of 5 .....	13-54
Enable/Disable Chinese 2 of 5 .....	13-54
Matrix 2 of 5 .....	13-55
Enable/Disable Matrix 2 of 5 .....	13-55
Set Lengths for Matrix 2 of 5 .....	13-56
Matrix 2 of 5 Redundancy .....	13-57
Matrix 2 of 5 Check Digit .....	13-57
Transmit Matrix 2 of 5 Check Digit .....	13-58
Inverse 1D .....	13-58
Postal Codes .....	13-59
US Postnet .....	13-59
US Planet .....	13-59
Transmit US Postal Check Digit .....	13-60
UK Postal .....	13-60
Transmit UK Postal Check Digit .....	13-61
Japan Postal .....	13-61
Australian Postal .....	13-62



Netherlands KIX Code .....	13-62
USPS 4CB/One Code/Intelligent Mail .....	13-63
UPU FICS Postal .....	13-63
GS1 DataBar (formerly RSS - Reduced Space Symbology) .....	13-64
GS1 DataBar-14 .....	13-64
GS1 DataBar Limited .....	13-64
GS1 DataBar Expanded .....	13-65
Convert GS1 DataBar to UPC/EAN .....	13-65
Composite .....	13-66
Composite CC-C .....	13-66
Composite CC-A/B .....	13-66
Composite TLC-39 .....	13-67
UPC Composite Mode .....	13-67
GS1-128 Emulation Mode for UCC/EAN Composite Codes .....	13-68
2D Symbologies .....	13-69
Enable/Disable PDF417 .....	13-69
Enable/Disable MicroPDF417 .....	13-69
Code 128 Emulation .....	13-70
Data Matrix .....	13-71
Data Matrix Inverse .....	13-71
Maxicode .....	13-72
QR Code .....	13-73
QR Inverse .....	13-73
MicroQR .....	13-74
Aztec .....	13-75
Aztec Inverse .....	13-75
Redundancy Level .....	13-76
Redundancy Level 1 .....	13-76
Redundancy Level 2 .....	13-76
Redundancy Level 3 .....	13-76
Redundancy Level 4 .....	13-76
Security Level .....	13-78
Security Level 0 .....	13-78
Security Level 1 .....	13-78
Security Level 2 .....	13-78
Security Level 3 .....	13-78
Intercharacter Gap Size .....	13-80
Macro PDF Features .....	13-81
Flush Macro Buffer .....	13-81
Abort Macro PDF Entry .....	13-81

## Chapter 14: Miscellaneous Scanner Options

Introduction .....	14-1
Scanning Sequence Examples .....	14-1
Errors While Scanning .....	14-1
Miscellaneous Default Parameters .....	14-2
Miscellaneous Scanner Parameters .....	14-3
Transmit Code ID Character .....	14-3
Prefix/Suffix Values .....	14-4

Scan Data Transmission Format .....	14-5
FN1 Substitution Values .....	14-6
Transmit “No Read” Message .....	14-7
Report Version .....	14-7

**Chapter 15: Advanced Data Formatting**

Introduction .....	15-1
Rules: Criteria Linked to Actions .....	15-1
Creating ADF Rules .....	15-2
ADF Programming Example .....	15-2
Rule 1: The Code 128 Scanning Rule .....	15-3
Rule 2: The UPC Scanning Rule .....	15-3
Alternate Rule Sets .....	15-3
Rules Hierarchy (in Bar Codes) .....	15-5
Default Rules .....	15-5
Special Considerations for Multipoint Networks .....	15-5
ADF Bar Codes .....	15-6
Special Commands .....	15-8
Pause Duration .....	15-8
Begin New Rule .....	15-8
Save Rule .....	15-8
Erase .....	15-9
Quit Entering Rules .....	15-9
Disable Rule Set .....	15-10
Criteria .....	15-11
Code Types .....	15-11
Code Lengths .....	15-18
Message Containing a Specific Data String .....	15-23
Actions .....	15-27
Send Data .....	15-27
Setup Field(s) .....	15-31
Modify Data .....	15-36
Pad Data with Spaces .....	15-37
Pad Data with Zeros .....	15-41
Beeps .....	15-46
Send Keystroke (Control Characters and Keyboard Characters) .....	15-46
Send Right Control Key .....	15-82
Send Graphic User Interface (GUI) Characters .....	15-83
Turn On Rule Sets .....	15-88
Turn Off Rule Sets .....	15-89
Alphanumeric Keyboard .....	15-90

**Appendix A: Standard Default Parameters**

**Appendix B: Programming Reference**

Symbol Code Identifiers .....	B-1
AIM Code Identifiers .....	B-3

**Appendix C: Sample Bar Codes**

UPC-A .....	C-1
UPC-E .....	C-1
UPC-E1 .....	C-2
EAN-13 .....	C-2
EAN-8 .....	C-2
Code 39 .....	C-3
Trioptic Code 39 .....	C-3
Code 93 .....	C-3
Code 11 .....	C-3
Codabar .....	C-4
MSI .....	C-4
Interleaved 2 of 5 .....	C-4
GS1 DataBar-14 .....	C-4
PDF417 .....	C-5
Data Matrix .....	C-5
Maxicode .....	C-5
QR Code .....	C-6
US Postnet .....	C-6
UK Postal .....	C-6

**Appendix D: Numeric Bar Codes**

0, 1, 2, 3 .....	D-1
4, 5, 6, 7 .....	D-2
8, 9 .....	D-3
Cancel .....	D-3

**Glossary****Index****Tell Us What You Think...**



# About This Guide

---

## Introduction

The *Symbol DS3478 Smart Focus Digital Scanner Product Reference Guide* provides general instructions for setting up, operating, maintaining, and troubleshooting the digital scanner.

---

## Configurations

This guide includes the following configurations:

- DS3478-SF - Standard focus
- DS3478-HD - High density scanning
- DS3478-DP - Direct part mark (DPM) decoding support.

---

## Chapter Descriptions

- [Chapter 1, Getting Started](#) provides a product overview and unpacking instructions.
- [Chapter 2, Digital Scanning](#) describes parts of the digital scanner, beeper and LED definitions, and how to use the digital scanner.
- [Chapter 3, Maintenance and Technical Specifications](#) provides information on how to care for the digital scanner, troubleshooting, and technical specifications.
- [Chapter 4, User Preferences](#) provides programming bar codes for selecting user preference features for the digital scanner.
- [Chapter 5, Decoding Preferences](#) describes digital scanner preference features and provides programming bar codes for selecting these features.
- [Chapter 6, Keyboard Wedge Interface](#) provides information for setting up the digital scanner for keyboard wedge operation.
- [Chapter 7, RS-232 Interface](#) provides information for setting up the digital scanner for RS-232 operation.
- [Chapter 8, USB Interface](#) provides information for setting up the digital scanner for USB operation.

- [Chapter 9, IBM 468X/469X Interface](#) provides information for setting up the digital scanner with IBM 468X/469X POS systems.
- [Chapter 10, Wand Emulation Interface](#) provides information for setting up the digital scanner for wand emulation operation.
- [Chapter 11, Scanner Emulation Interface](#) provides information for setting up the digital scanner for scanner emulation operation.
- [Chapter 12, 123Scan](#) provides information on the PC-based scanner configuration tool 123Scan.
- [Chapter 13, Symbologies](#) describes all symbology features and provides programming bar codes for selecting these features.
- [Chapter 14, Miscellaneous Scanner Options](#) includes features frequently used to customize how data transmits to the host device.
- [Chapter 15, Advanced Data Formatting](#) (ADF) describes how to customize scanned data before transmitting to the host.
- [Appendix A, Standard Default Parameters](#) provides a table of all host and miscellaneous scanner defaults.
- [Appendix B, Programming Reference](#) provides tables of Symbol and AIM code identifiers and modifier characters.
- [Appendix C, Sample Bar Codes](#) includes sample bar codes for supported code types.
- [Appendix D, Numeric Bar Codes](#) includes the numeric bar codes to scan for parameters requiring specific numeric values.

---

## Notational Conventions

The following conventions are used in this document:

- Bullets (•) indicate:
  - action items
  - lists of alternatives
  - lists of required steps that are not necessarily sequential.
- Sequential lists (e.g., those that describe step-by-step procedures) appear as numbered lists.
- Throughout the programming bar code menus, asterisks (\*) denote default parameter settings.

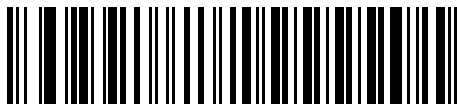

\* Indicates Default — \*Baud Rate 9600 — Feature/Option

---

## Related Publications

The *Symbol DS3478 Quick Start Guide* (p/n 72-72130-xx) provides general information for getting started with the digital scanner, including basic setup and operation instructions.

For the latest version of this guide and all guides, go to: <http://www.motorola.com/enterprisemobility/manuals>.

---

## Service Information

If you have a problem with your equipment, contact Motorola Enterprise Mobility support for your region. Contact information is available at: <http://www.motorola.com/enterprisemobility/contactsupport>.

When contacting Enterprise Mobility Support, please have the following information available:

- Serial number of the unit
- Model number or product name
- Software type and version number.

Motorola responds to calls by E-mail, telephone or fax within the time limits set forth in support agreements.

If your problem cannot be solved by Motorola Enterprise Mobility Support, you may need to return your equipment for servicing and will be given specific directions. Motorola is not responsible for any damages incurred during shipment if the approved shipping container is not used. Shipping the units improperly can possibly void the warranty.

If you purchased your Enterprise Mobility business product from a Motorola business partner, contact that business partner for support.





# Chapter 1 Getting Started

---

## Introduction

The Symbol DS3478 combines excellent digital scanning performance and advanced ergonomics to provide the best value in a lightweight digital scanner, ensuring comfort and ease of use for extended periods of time.

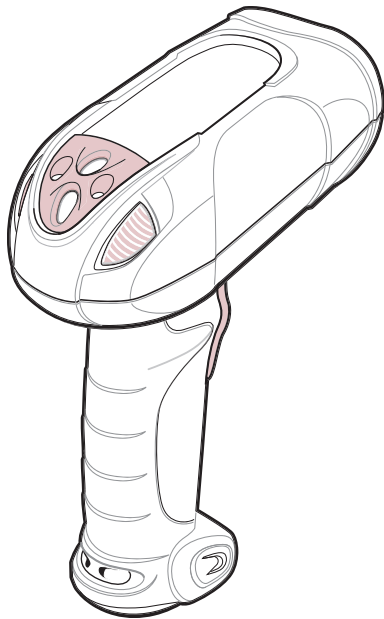

**Figure 1-1** *Symbol DS3478 Smart Focus Digital Scanner*

## Smart Focus Scanning

The digital scanner supports a Smart Focus mode which toggles the focus position after every frame between near and far focus, optimizing decoding performance when scanning a combination of small and large bar codes. See [Focus Mode on page 5-3](#) to select this mode.

## Host Interfaces

This digital scanner supports the following host interfaces through communication with a cradle:

- Standard RS-232 connection to a host.
- Keyboard wedge connection to a host, where scanned data is interpreted as keystrokes. The following international keyboards are supported (for Windows™ environment): North American, German, French, French Canadian, Spanish, Italian, Swedish, UK English, Japanese, and Brazilian-Portuguese.
- Wand emulation connection to a mobile computer, a controller, or host, which collects the data as wand data and decodes it.
- Scanner emulation connection to a mobile computer or a controller, which collects the data and interprets it for the host.
- IBM® 468X/469X hosts.
- USB connection to a host. The digital scanner autodetects a USB host and defaults to the HID keyboard interface type. Select other USB interface types by scanning programming bar codes. The following international keyboards are supported (for Windows™ environment): North America, German, French, French Canadian, Spanish, Italian, Swedish, UK English, Japanese, and Brazilian-Portuguese.
- Synapse capability, which allows connection to a wide variety of host systems using a Synapse cable and Synapse adapter cable. The digital scanner autodetects the Synapse interface.
- Configuration via 123Scan.

---

## Unpacking the Digital Scanner

Remove the digital scanner from its packing and inspect it. If the digital scanner was damaged in transit, contact Motorola Enterprise Mobility Support. See [page xvii](#) for contact information. **KEEP THE PACKING.** It is the approved shipping container and should be used if the equipment needs to be returned for servicing.

---

## The Digital Scanner Cradle

The digital scanner cradle serves as a stand, charger, and host interface for the digital scanner. There are two versions of the cradle:

- **Charging cradle with radio:** All communication between the cordless digital scanner and the host computer occurs through the cradle. Each bar code contains programming instructions or other data unique to the bar code pattern. The digital scanner transmits bar code data to the cradle via a wireless radio antenna. The cradle then sends that information via an interface cable to the host computer for interpretation.
- **Charge-only cradle:** This cradle serves as a stand and battery charger. Since one radio-enabled cradle can receive information from up to four digital scanners, it is possible to have several charge-only cradles.

The charging cradle with radio supports two modes of operation:

- **Single point mode:** the cradle communicates with one digital scanner.
- **Multipoint mode:** the cradle communicates with more than one digital scanner.

The cradle sits on a desktop or mounts on a non-horizontal surface (such as a wall or forklift), depending on the environment. For more information about mounting options and procedures, refer to the documentation included with the cradle.

## Cradle Parts

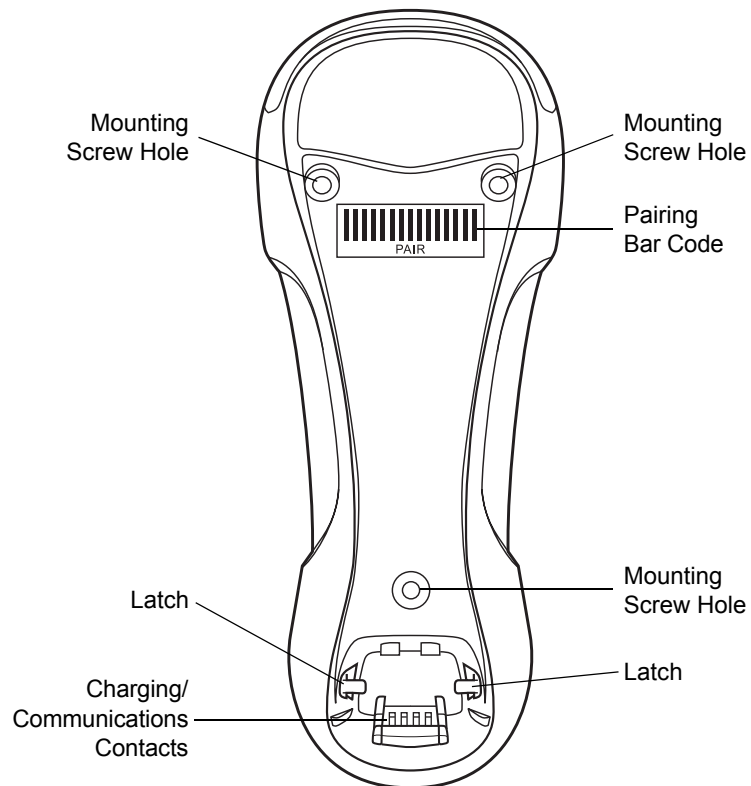

**Figure 1-2** Cradle Front View

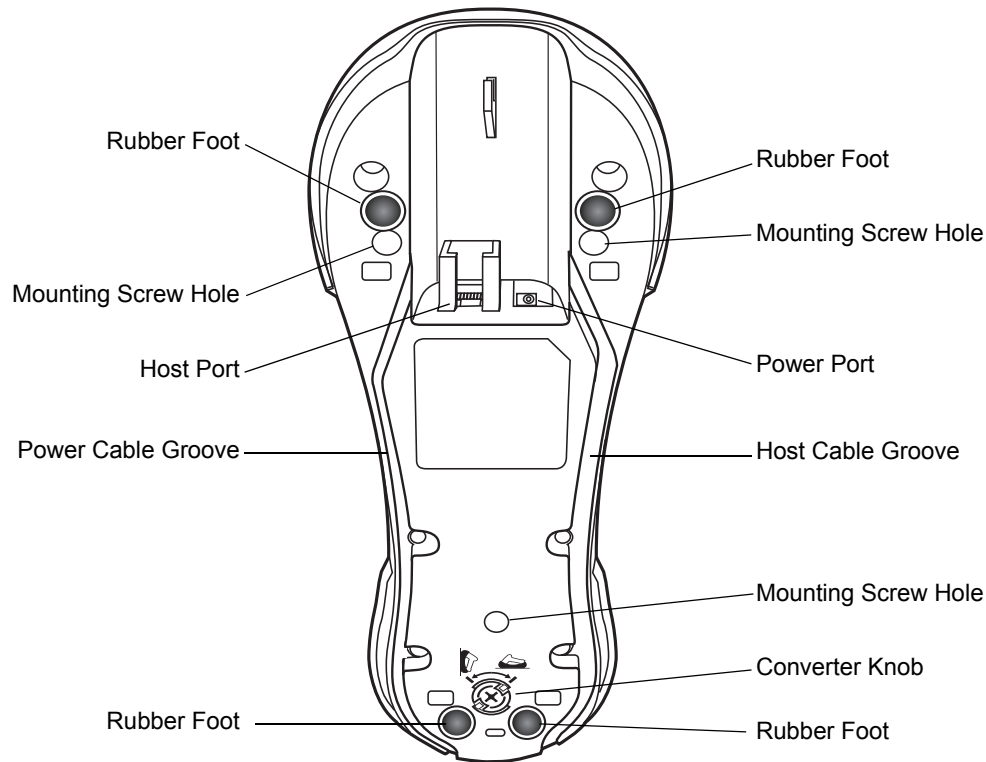

**Figure 1-3** Cradle Back View

## Connecting the Cradle

**Important:** Connect the interface cable and power supply in the following order to ensure proper operation of the digital scanner and cradle. Note that this procedure includes two different power supply options.

1. Disconnect the power supply from the digital scanner cradle. See [Figure 1-4](#).
2. Insert the modular connector of the interface cable into the host interface port on the back of the digital scanner cradle.
3. If using a power supply that connects to the interface cable, insert this power supply into the power connector on the interface cable, and the other end into an AC supply (see the cradle's *Quick Reference Guide* for more information).
4. Insert the other end of the interface cable into the appropriate port on the host computer (see the specific host chapter for information on host connections).

- If using an external power supply, insert the power cable into the power port on the back of the digital scanner cradle, and connect the power supply to an approved AC supply (see the cradle's *Quick Reference Guide* for more information).

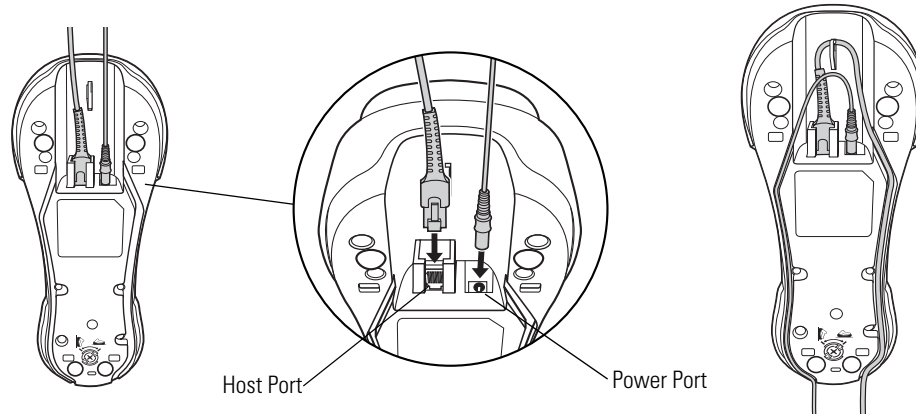

**Figure 1-4** Connecting the Cables to the Cradle



**NOTE** Disconnect the power supply before changing host cables, or the digital scanner may not recognize the new host.

Different hosts require different cables. The connectors illustrated in each host chapter are examples only. The connectors may be different from those illustrated, but the steps to connect the digital scanner are the same.

## Supplying Power to the Cradle

The cradle receives power from one of two sources:

- An external power supply.
- When connected to a powered host through a host cable that supplies power.

The cradle detects whether the host or an external supply is supplying power. It always draws power from the external supply when available, regardless of the presence of power from a host.

### Using the Host to Supply Power

When connecting the cradle to a powered host, the host can sometimes power the cradle rather than an external power supply. Consider the following when powering from a host:

- The digital scanner charges at a slower rate than when charging from an external power supply.
- The cradle can charge a digital scanner only in single point mode. An external power supply is required to charge a digital scanner in multipoint mode.
- A powered USB port provides enough power to the cradle for charging.
- Not all hosts provide enough power to the cradle for charging. For these hosts, connect an external power supply.



**NOTE** The radio link functions normally when the cradle draws power from a host.

For more information on single and multipoint operation, see [Pairing on page 1-9](#).

## Connecting a Synapse Cable Interface

✓ **NOTE** Refer to the *Synapse Interface Guide* provided with the Synapse cable for more information.

Synapse Smart Cables enable interfacing to a variety of hosts. The appropriate Synapse cable detects the host.

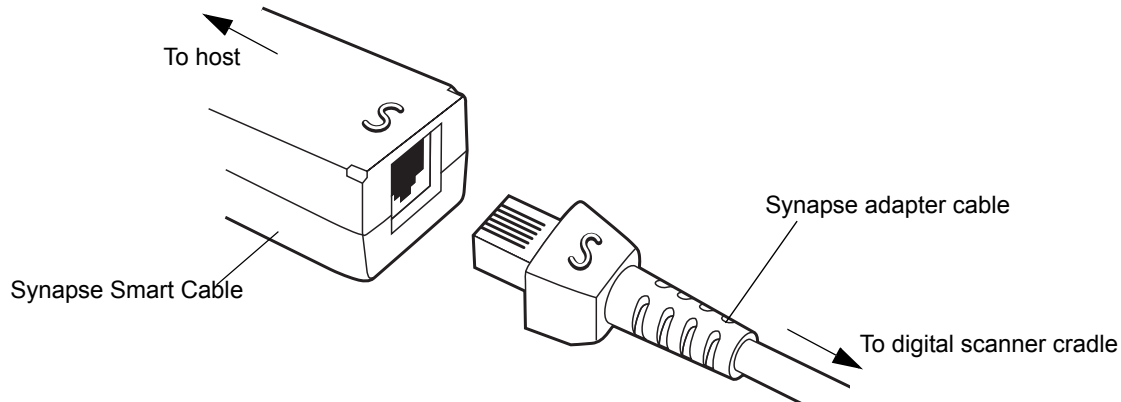

**Figure 1-5** Synapse Cable Connection

1. Plug the Synapse adapter cable into the bottom of the digital scanner cradle, as described in [Connecting the Cables to the Cradle on page 1-5](#).
2. Align the 'S' on the Synapse adapter cable with the 'S' on the Synapse Smart Cable and plug the cable in.
3. Connect the other end of the Synapse Smart Cable to the host.

## Reestablishing a Lost Connection to Host

If scanned data does not transmit to the cradle's host, ensure you connected all cables securely, including the power supply. If scanned data still does not transmit to the host, reestablish connection with the host:

1. Disconnect the power supply from the cradle.
2. Disconnect the host interface cable from the cradle.
3. Wait three seconds.
4. Reconnect the host interface cable to the cradle.
5. Reconnect the power supply to the cradle.
6. Re-establish pairing with the cradle.

## Mounting the Cradle

For information on mounting the cradle, refer to the documentation included with the cradle.

---

## Removing and Inserting the Battery

The battery resides in a chamber in the digital scanner handle. To insert the battery:

1. Insert a coin or flathead screwdriver in the slot at the base of the digital scanner, then turn the slot counterclockwise to release the latch.
2. Open the latch.
3. If a battery is already installed, turn the digital scanner upright to slide the battery out.
4. Slide the new battery into the chamber, with the rounded side toward the back and the contacts facing into the chamber.

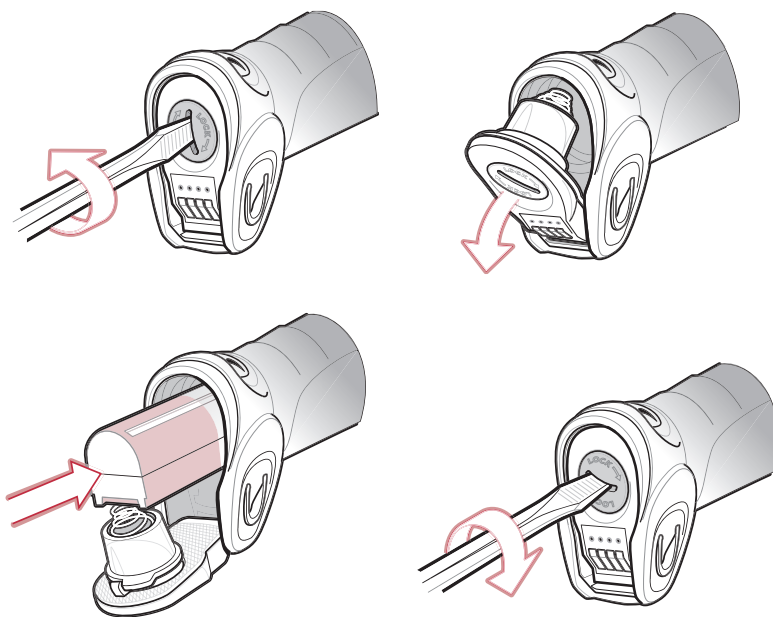

**Figure 1-6** *Inserting the Battery*

5. Close the latch.
6. Insert a coin or flathead screwdriver in the slot at the base of the digital scanner, press down gently, and turn the slot clockwise to lock the latch in place.

---

## Charging the Battery

For best performance, fully charge the digital scanner battery before using the digital scanner for the first time. To charge the battery, place the digital scanner in the cradle, ensuring that the metal contacts on the bottom of the digital scanner touch the contacts on the cradle. The battery begins charging. A complete charge can take up to four hours, depending on the remaining charge in the battery.

Charge within the recommended temperature of 32° to 104° F (0° to 40° C) nominal, 41° to 95° F (5° to 35° C) ideal.

### Charging LED

The flashing green LED indicates charging activity. See [Table 2-2 on page 2-5](#). If the digital scanner is charging in fast mode (external power supply is present), the green LED blinks quickly (on for 0.25 seconds, off for 0.75 seconds). If the digital scanner is charging in slow mode (host-powered mode), the LED blinks slowly (on for 0.5 seconds, off for 1.5 seconds).

### Charging Problem LED

A solid or flashing red LED during charging indicates a charging problem. See [Table 2-2 on page 2-5](#) for definitions of error conditions and the appropriate action to take.



---

## Inserting the Digital Scanner in the Cradle

Insert the digital scanner in the cradle so that the metal contacts on the bottom of the digital scanner handle touch the contacts on the cradle:

1. With a slightly rotated motion, insert the digital scanner into the cradle top first.
2. Push the handle down until it clicks into place, engaging the contacts in the cradle and digital scanner.

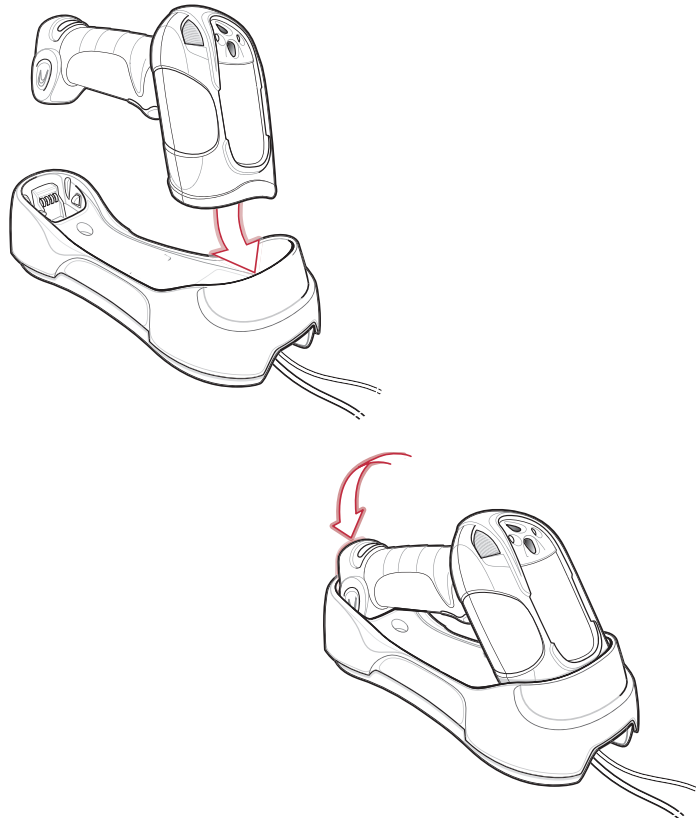

**Figure 1-7** *Inserting the Digital Scanner in the Cradle*

---

## Pairing

Pairing is the process by which a digital scanner initiates communication with a cradle. The cradle has multipoint capability, and can pair with up to four digital scanners at a time. The cradle includes a pairing bar code.

To pair the digital scanner with the cradle, scan the pairing bar code on the cradle. A short low-high beep indicates successful pairing.

- ✓ **NOTE** The pairing bar code that connects the digital scanner to a cradle is unique to each cradle. Do not scan data or parameters until pairing completes.

## Unpairing

Unpair the digital scanner from the cradle to make the cradle available for pairing with another digital scanner. Scan the **Unpairing** bar code on [page 4-13](#) to unpair the digital scanner from its cradle.



**NOTE** The *Symbol DS3478 Quick Start Guide* also includes an unpairing bar code.

---

## Configuring the Digital Scanner

Use the bar codes in this manual or the 123Scan configuration program to configure the digital scanner. See [Chapter 4, User Preferences](#) and each host chapter for information about programming the digital scanner using bar code menus. See [Chapter 12, 123Scan](#) to configure the digital scanner using this configuration program. 123Scan includes a help file.

# Chapter 2 Digital Scanning

---

## Introduction

This chapter provides beeper and LED definitions, digital scanning techniques, general scanning instructions and tips, and decode zone diagrams.

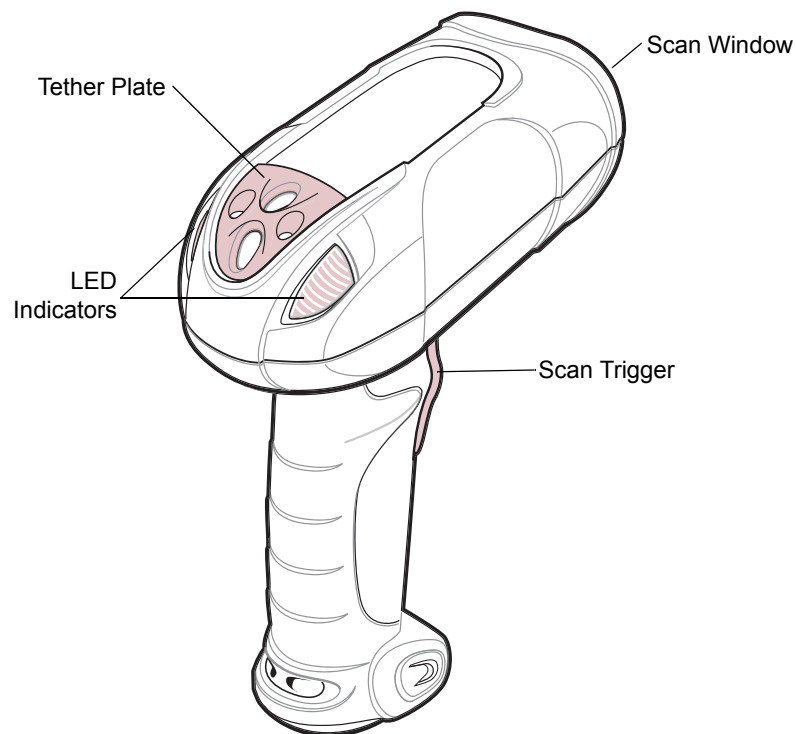

**Figure 2-1** *Parts of the Digital Scanner*

## Beeper Definitions

The digital scanner emits different beeper sequences and patterns to indicate its status. [Table 2-1](#) defines beep sequences that occur during both normal scanning and while programming the digital scanner.

**Table 2-1** Standard Beeper Definitions

Beeper Sequence	Indication
<b>Standard Use</b>	
Short low-short medium-short high beeps	Power up.
One short high beep	The digital scanner successfully decoded a bar code (if the decode beeper is enabled).
Four long low beeps	A communication error occurred while transmitting a scanned symbol to a host. The data is ignored. This occurs if the digital scanner is not properly configured or if the digital scanner has disconnected from the cradle.
Long low-high beeps	Attempt to pair with the cradle was unsuccessful. Ensure that the cradle has power; if not, cycle power to the cradle and re-attempt the pairing.
Four short high beeps	Low battery indication.
Long low-high-low-high beeps	Attempt to pair with a cradle that is already paired with the maximum number of digital scanners.
Five long low beeps	Conversion or format error.
Low-high-low beeps	ADF transmit error.
Short high-short high-short low-short low beeps	Radio failure.
<b>Cordless Digital Scanner Connection</b>	
Short low-short high beeps	The digital scanner connected to the cradle after scanning a pairing bar code or automatically after a disconnect.
Short high-short low beeps	The digital scanner disconnected from the cradle either because the digital scanner moved out of range of the cradle, the USB host suspended the cradle, or cradle power was interrupted.
<b>Parameter Menu Scanning</b>	
Short high beep	Correct entry scanned or correct menu sequence performed.
Long low-long high beeps	Input error; incorrect bar code, programming sequence or <b>Cancel</b> scanned. The digital scanner remains in ADF program mode.
Short high-short low beeps	Keyboard parameter selected. Enter value using numeric bar codes.

**Table 2-1** Standard Beeper Definitions (Continued)

Beeper Sequence	Indication
Short high-short low-short high-short low beeps	Successful program exit with change in the parameter setting.
<b>Code 39 Buffering</b>	
High-low beeps	New Code 39 data was entered into the buffer.
Three long high beeps	Code 39 buffer is full.
Low-high-low beeps	The Code 39 buffer was erased or there was an attempt to clear or transmit an empty buffer.
Low-high beeps	A successful transmission of buffered data.
<b>Macro PDF</b>	
Two long low beeps	File ID error. A bar code not in the current Macro PDF sequence was scanned.
Three long low beeps	Out of memory. There is not enough buffer space to store the current Macro PDF symbol.
Four long low beeps	Bad symbology. Scanned a 1D or 2D bar code in a Macro PDF sequence, a duplicate Macro PDF label, a label in an incorrect order, or trying to transmit an empty or illegal Macro PDF field.
Five long low beeps	Flushing Macro PDF buffer.
Fast warble beep	Aborting Macro PDF sequence.
Low-high beeps	Flushing an already empty Macro PDF buffer.
<b>ADF Programming Normal Data Entry</b>	
High-low beeps	Enter another digit. Add leading zeros to the front if necessary.
Low-low beeps	Enter another alphabetic character or scan the <b>End of Message</b> bar code.
High-high beeps	Enter another criterion or action, or scan the <b>Save Rule</b> bar code.
High-low-high-low beeps	Rule saved. Rule entry mode exited.
High-low-low beeps	All criteria or actions cleared for current rule, continue entering rule.
Low beep	Delete last saved rule. The current rule is left intact.
Low-high-high beeps	All rules have been deleted.
Short low-short high-short low-short high beeps	Out of host ADF parameter storage space. Scan <a href="#">Set Default Parameter on page 4-3</a> .

**Table 2-1** Standard Beeper Definitions (Continued)

Beeper Sequence	Indication
<b>ADF Programming Error Indications</b>	
Low-high-low-high beeps	Out of rule memory. Erase some existing rules, then try to save rule again. (It is not necessary to re-enter the current rule.)
Low-high-low beeps	Cancel rule entry. Rule entry mode exited because of an error or the user asked to exit rule entry.
<b>Host Specific</b>	
<b>USB only</b>	
Four short high beeps	The digital scanner did not complete initialization. Wait several seconds and scan again.
Short low-short medium-short high beep sequence after scanning a USB device type	The digital scanner must establish communication with the bus before it can operate at the highest power level.
Short low-short medium-short high beep sequence occurs more than once	The USB bus can put the digital scanner in a state where power to the digital scanner is cycled on and off more than once. This is normal and usually happens when the PC cold boots.
<b>RS-232 only</b>	
Short high beep	A <BEL> character is received and Beep on <BEL> is enabled.
Low-high beeps	Entry error, wrong bar code scanned. Re-enter criterion or action. All previously entered criteria and actions are retained. Criteria or action list is too long for a rule.

## LED Definitions

In addition to beeper sequences, the digital scanner uses a two-color LED to indicate its status. [Table 2-2](#) explains LED sequences.

**Table 2-2** LED Status Indications

LED	Indication
<b>Standard Use</b>	
Off	No power is applied to the digital scanner, or the digital scanner is on and ready to scan.
Green	The digital scanner successfully decoded a bar code.
Red	A data transmission error or digital scanner malfunction occurred.
<b>Charging Use</b>	
Green Slow Flash	The digital scanner is in the cradle and is charging in slow mode (occurs when the host cable powers the cradle).
Green Fast Flash	The digital scanner is in the cradle and is charging in rapid mode (occurs when an external power supply powers the cradle).
Red fast flash (two flashes per second)	Overcharge condition. Contact Motorola Enterprise Mobility Support.
Red slow flash (one flash per second)	Battery voltage not increasing with charge. Replace the battery.
Red and green flash	Temperature fault. Move the cradle to a location where the temperature is 0° - 40° C; optimal charging temperature is 5° - 35° C.

## Digital Scanning

See [Chapter 1, Getting Started](#) to install and program the digital scanner. Also see [DPM Scanning on page 5-5](#) for DS3478-DP (DPM) digital scanning. To scan:

1. Aim the digital scanner at the bar code.
2. Press the scan trigger.

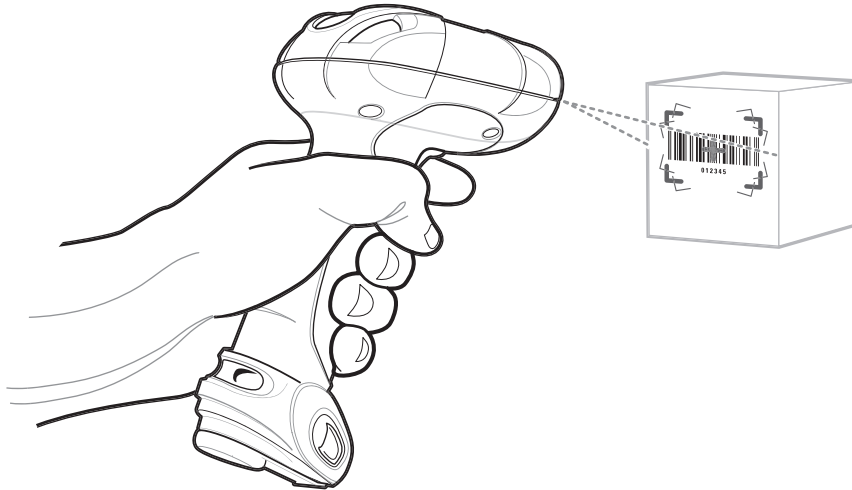

**Figure 2-2** Aiming the Digital Scanner

The digital scanner projects a red laser aiming pattern which allows positioning the bar code or object within the field of view.

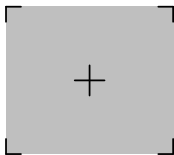

**Figure 2-3** Laser Aiming Pattern

If necessary, the digital scanner turns on its red LEDs to illuminate the target bar code.

3. Center the symbol in any orientation within the aiming pattern. Be sure the entire symbol is within the rectangular area formed by the brackets in the pattern.

1D bar code symbol

2D bar code symbol

2D dot peen DPM symbol

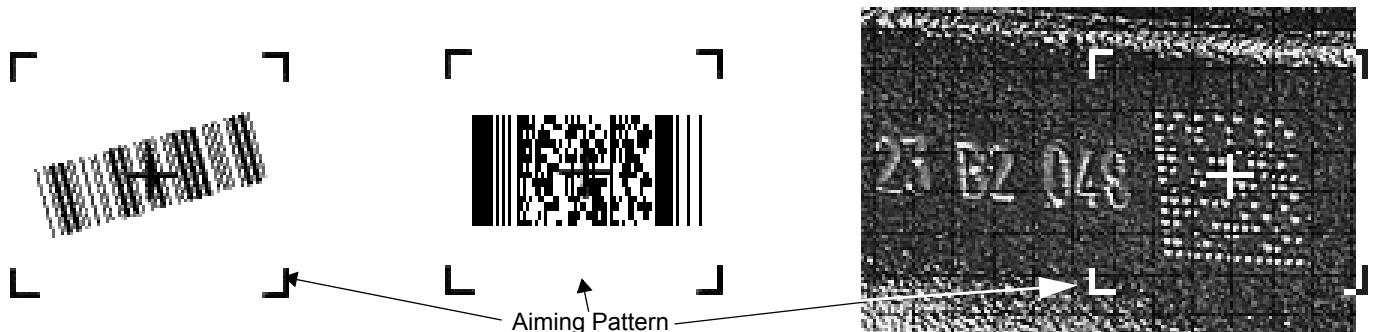

**Figure 2-4** Centering Symbol in Aiming Pattern



4. Hold the trigger until the digital scanner beeps, indicating it successfully decoded the bar code. For more information on beeper and LED definitions, see [Table 2-1](#) and [Table 2-2](#).

This process usually occurs instantaneously. Steps 2 - 4 are repeated on poor quality or difficult bar codes, until the bar code decodes, you release the trigger, or the Decode Session Timeout occurs.

- ✓ **NOTE** Scanning Direct Part Marks (DPMs) with the DS3478-DP (DPM) Digital Scanner: Due to the reflective nature of some surfaces used with DPMs (see [Figure 2-4 on page 2-6](#)), to achieve the best results when scanning DPMs, tilt the scanner at an angle relative to the target (25-45 degrees is recommended). As a guide, if you are decoding a 23 mil dot peen mark and the scanner is set to the near field focus, present the target between one and four inches from the nose of the scanner at a minimum tilt of 30 degrees.

When scanning standard (non-DPM) bar codes with any configuration of the DS3478 digital scanner, follow the standard aiming instructions described in [Aiming](#).

## Aiming

Hold the digital scanner between two and nine inches (depending on symbol density; see [Decode Zones on page 2-8](#)) from the symbol, centering the aiming pattern cross hairs on the symbol.

The aiming pattern is smaller when the digital scanner is closer to the symbol and larger when it is farther from the symbol. Scan symbols with smaller bars or elements (mil size) closer to the digital scanner, and those with larger bars or elements (mil size) farther from the digital scanner.

The digital scanner can also read a bar code within the aiming pattern but not centered. The top examples in [Figure 2-5](#) show acceptable aiming options, while the bottom examples do not decode.

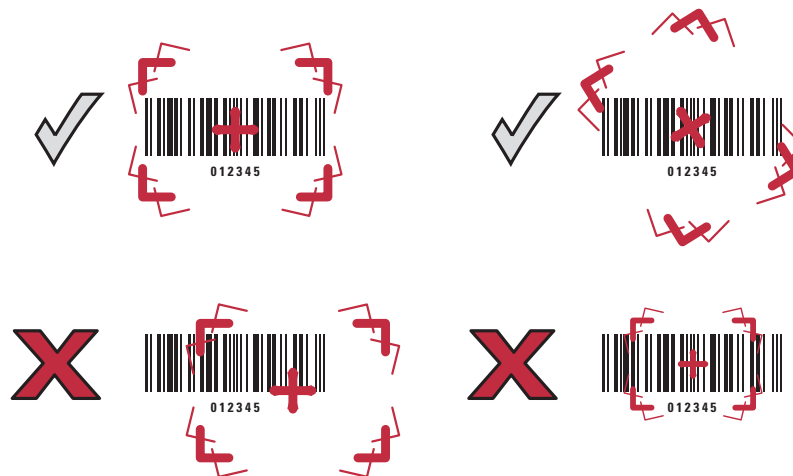
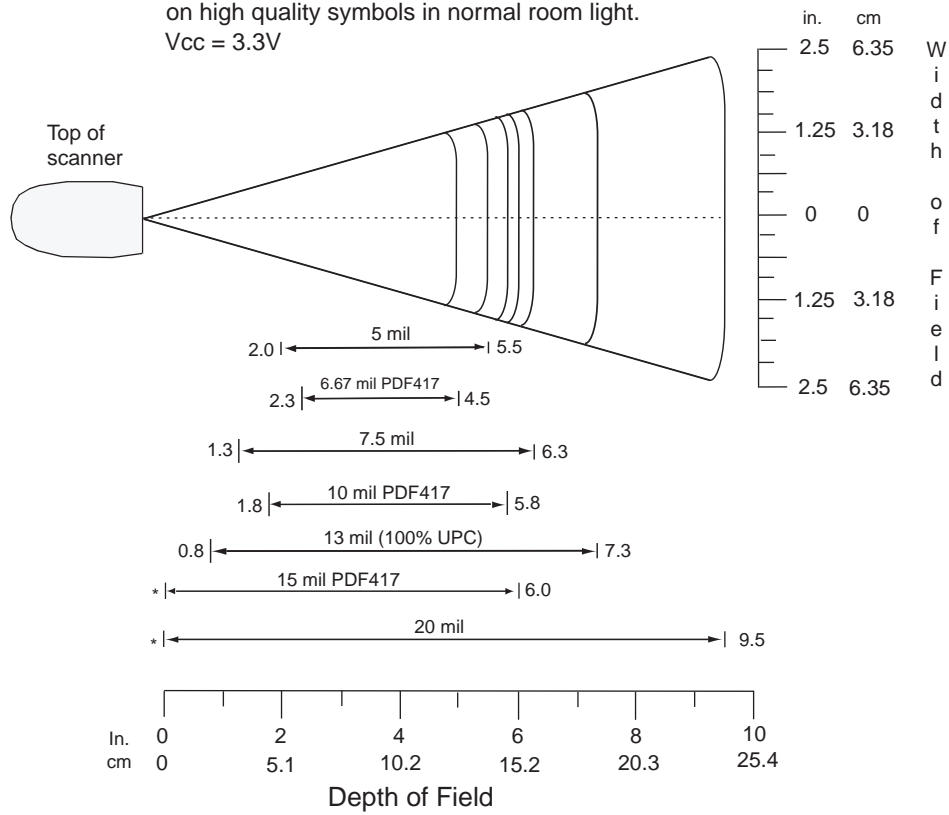

**Figure 2-5** *Acceptable and Incorrect Aiming*

## Decode Zones

### DS3478-SF Near Focus - 1D and PDF417

Note: Typical performance at 73°F (23°C)  
on high quality symbols in normal room light.  
Vcc = 3.3V



\* Minimum distance determined by symbol length and scan angle.

Figure 2-6 Symbol DS3478-SF Near Focus Decode Zone - 1D and PDF417

**DS3478-SF Near Focus - 2D Codes**

Note: Typical performance at 73°F (23°C)  
on high quality symbols in normal room light.  
Vcc = 3.3V

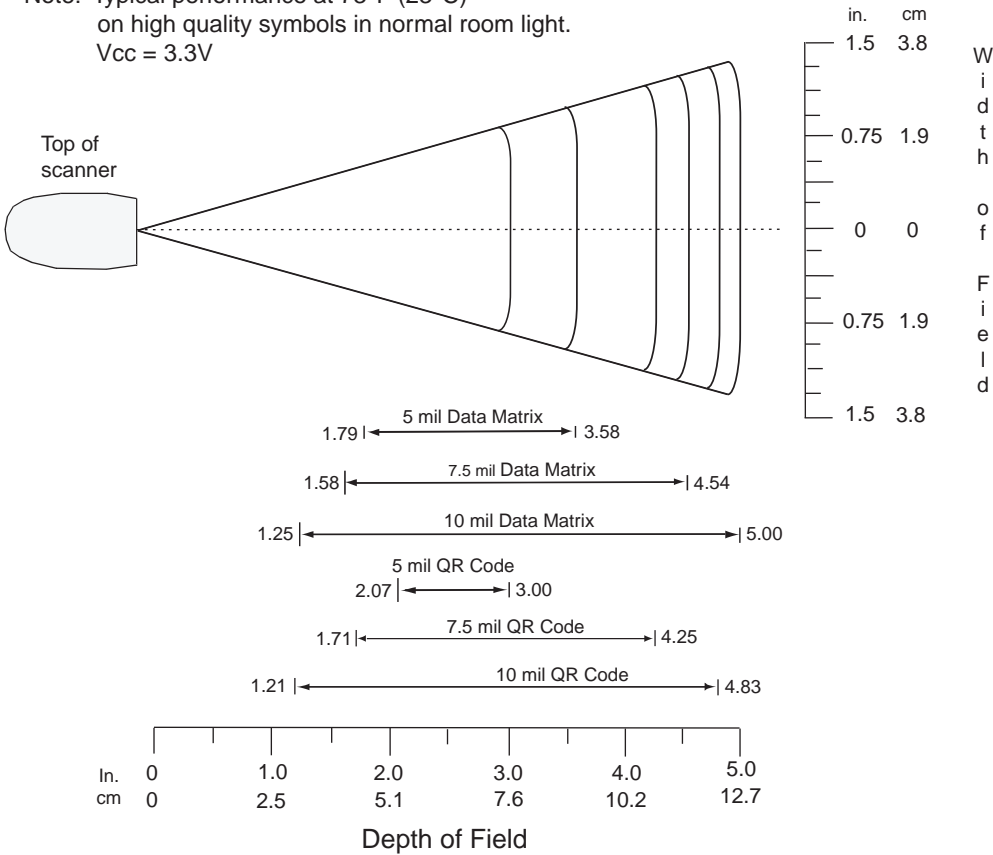

\* Minimum distance determined by symbol length and scan angle.

**Figure 2-7** Symbol DS3478-SF Near Focus Decode Zone - 2D Codes

### DS3478-SF Far Focus

Note: Typical performance at 73°F (23°C)  
on high quality symbols in normal room light.  
Vcc = 3.3V

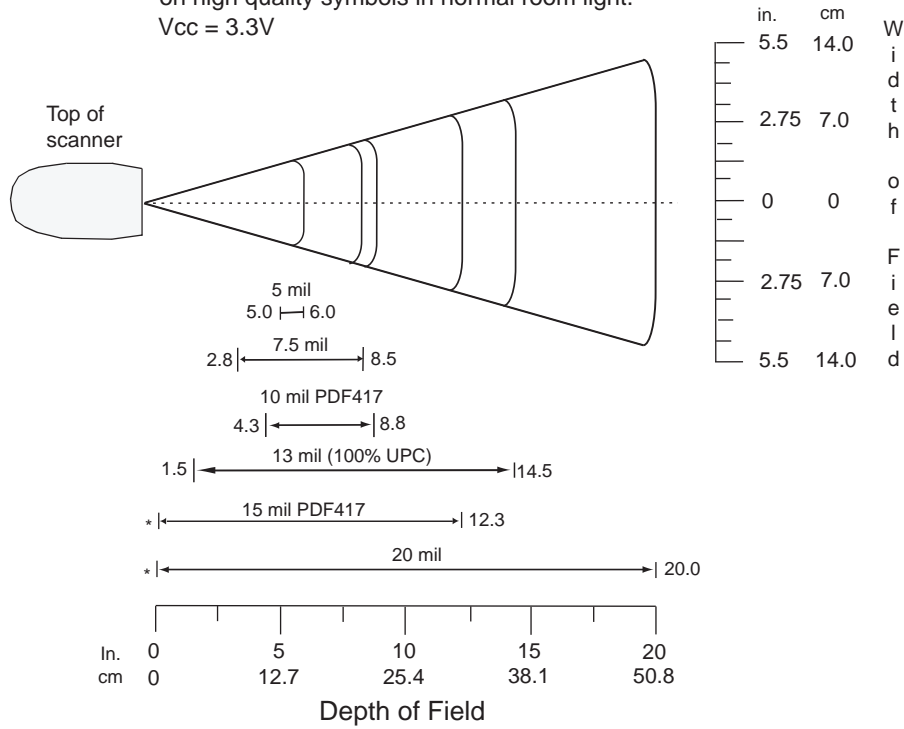
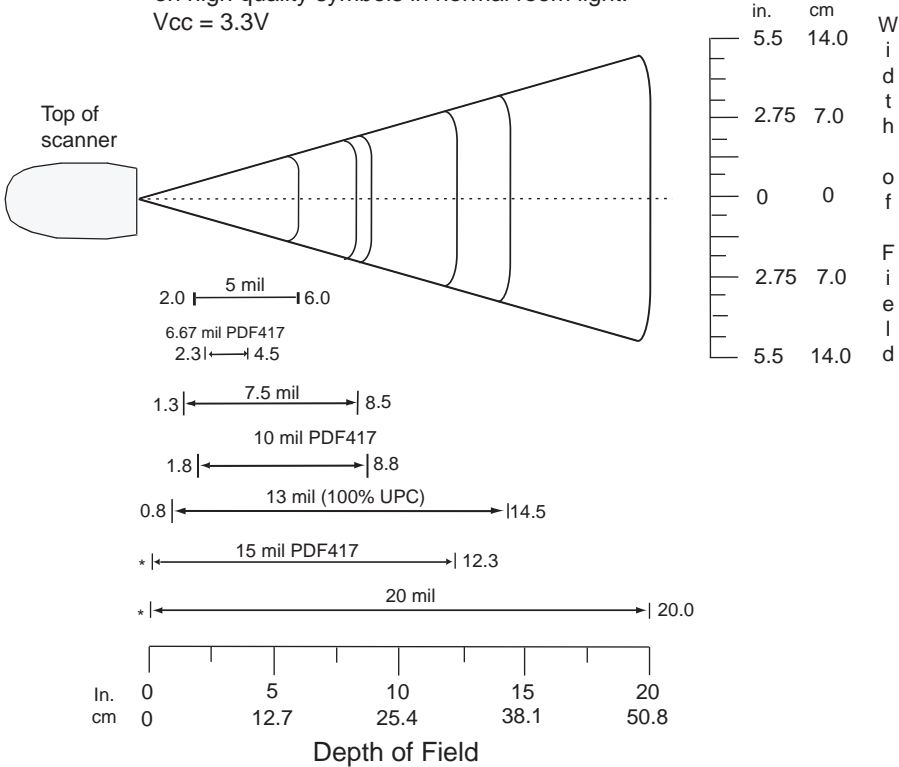

Figure 2-8 Symbol DS3478-SF Far Focus Decode Zone

**DS3478-SF Smart Focus**

Note: Typical performance at 73°F (23°C)  
 on high quality symbols in normal room light.  
 Vcc = 3.3V



\* Minimum distance determined by symbol length and scan angle.

**Figure 2-9** Symbol DS3478-SF Smart Focus Decode Zone

### DS3478-HD/DPM Near Focus - 1D and PDF417

Note: Typical performance at 73°F (23°C)  
on high quality symbols in normal room light.  
Vcc = 3.3V

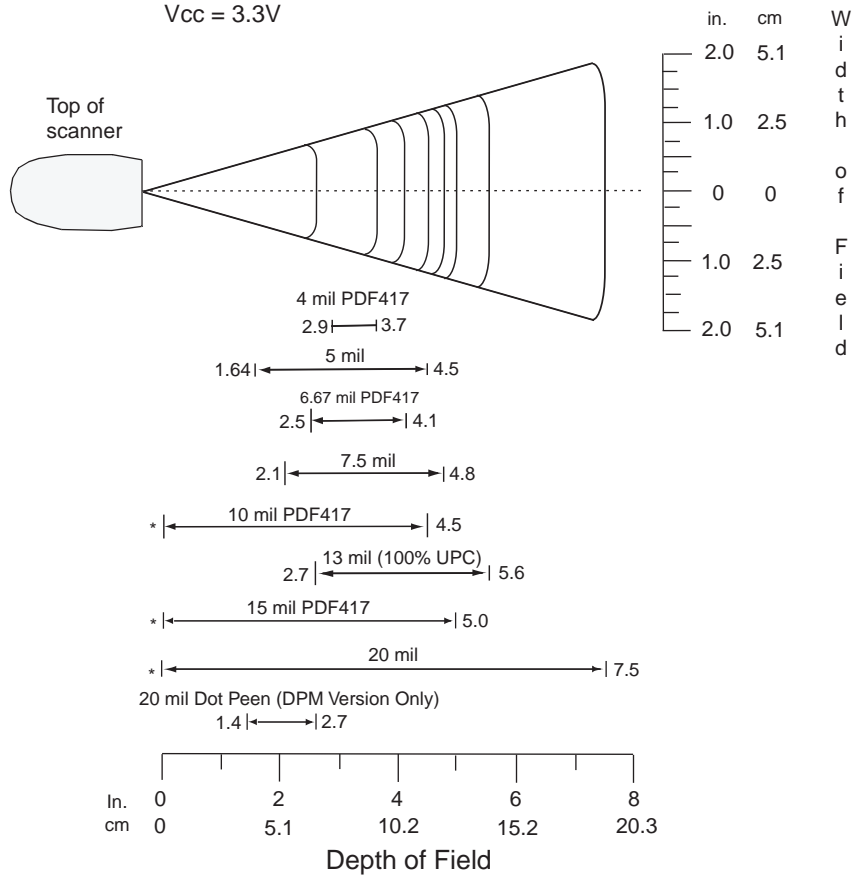

\* Minimum distance determined by symbol length and scan angle.

Figure 2-10 DS3478-HD/DPM Near Focus Decode Zone - 1D and PDF417

**DS3478-HD/DPM Near Focus - 2D Codes**

Note: Typical performance at 73°F (23°C)  
 on high quality symbols in normal room light.  
 Vcc = 3.3V

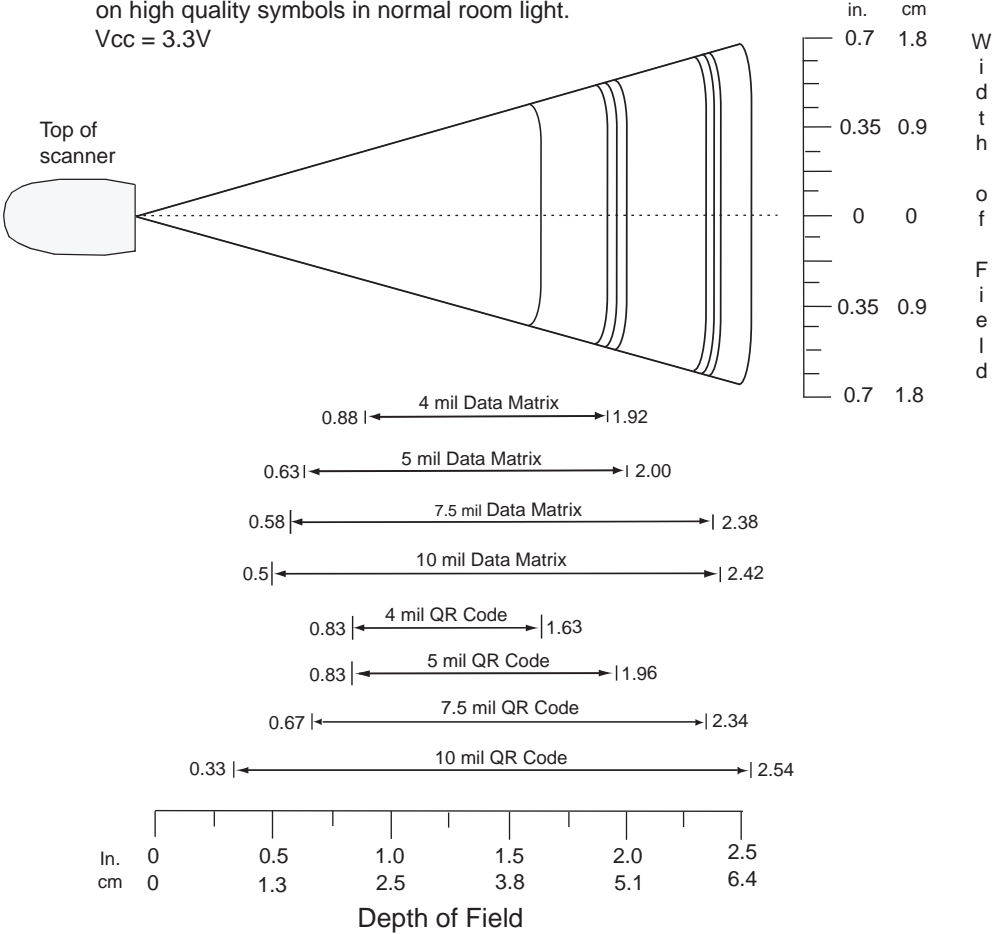

\* Minimum distance determined by symbol length and scan angle.

**Figure 2-11 DS3478-HD/DPM Near Focus Decode Zone - 2D Codes**

### DS3478-HD/DPM Far Focus

Note: Typical performance at 73°F (23°C)  
on high quality symbols in normal room light.  
Vcc = 3.3V

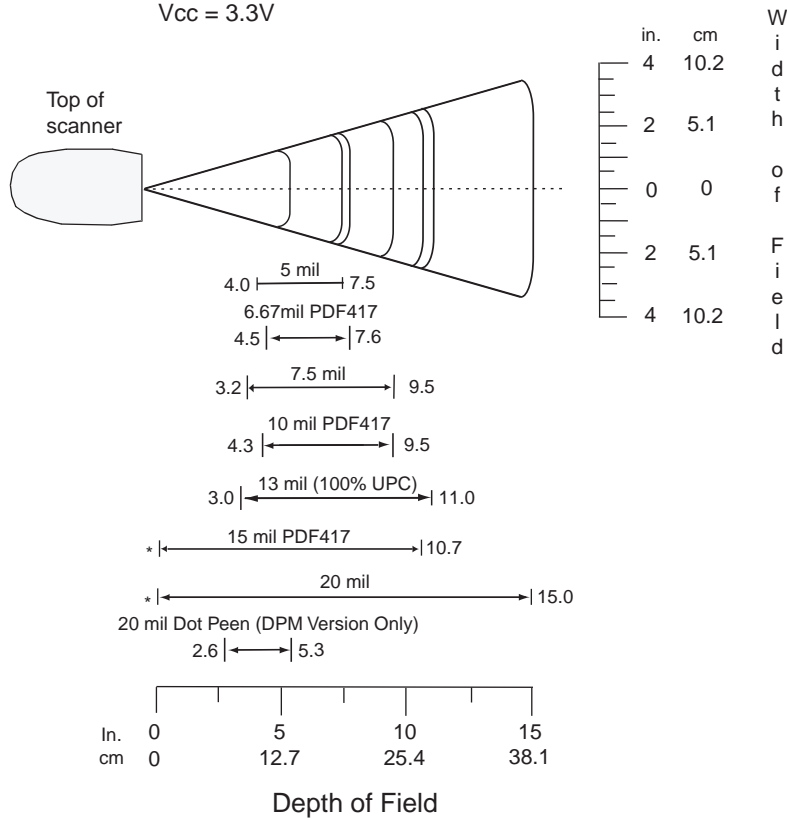

\* Minimum distance determined by symbol length and scan angle.

Figure 2-12 DS3478-HD/DPM Far Focus Decode Zone



**DS3478-HD/DMP Smart Focus**

Note: Typical performance at 73°F (23°C)  
on high quality symbols in normal room light.  
Vcc = 3.3V

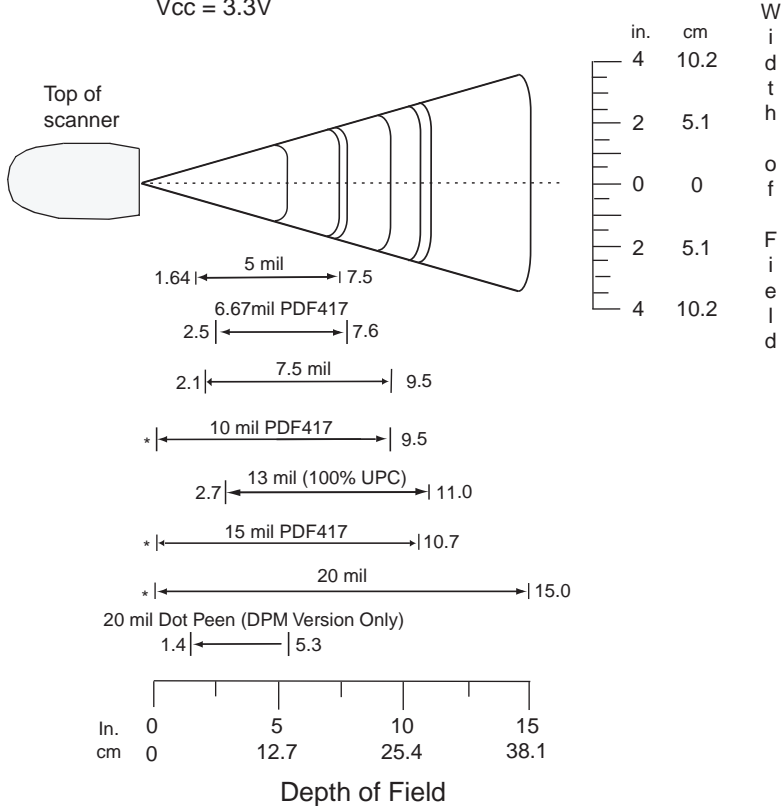

\* Minimum distance determined by symbol length and scan angle.

**Figure 2-13 DS3478-HD/DPM Smart Focus Decode Zone**



# Chapter 3 Maintenance and Technical Specifications

---

## Introduction

This chapter provides digital scanner maintenance and troubleshooting information, technical specifications, and signal descriptions (pinouts).

---

## Maintenance

Cleaning the scan window is the only maintenance required. A dirty window can affect scanning accuracy.

- Do not allow any abrasive material to touch the window.
- Remove any dirt particles with a damp cloth.
- Wipe the window using a tissue moistened with ammonia/water.
- Do not spray water or other cleaning liquids directly onto the window.

## Troubleshooting

**Table 3-1** *Troubleshooting*

Problem	Possible Causes	Possible Solutions
Nothing happens when the scan trigger is pressed.	No power to the digital scanner.	Check battery. Ensure that end cap to battery chamber is secured.
	The digital scanner is disabled.	For Synapse or IBM 468x mode, enable the digital scanner via the host interface. Otherwise, see the technical person in charge of scanning.
	If using RS-232 Nixdorf B mode, CTS is not asserted.	Assert CTS line.
	The aiming pattern is disabled.	Enable the aiming pattern. See <a href="#">Decode Aiming Pattern on page 5-4</a> .
	Decoding illumination is disabled.	Enable illumination. See <a href="#">Decoding Illumination on page 5-4</a> .
The digital scanner emits short low-short medium-short high beep sequence.	The digital scanner is powering up.	Normal when battery is inserted.
The digital scanner emits short high-short high-short low-short-low beep sequence.	Radio failure.	Cycle power to the cradle and re-attempt pairing.
The digital scanner emits the aiming pattern, but does not decode the bar code.	Digital scanner is not programmed for the correct bar code type.	Ensure the digital scanner is programmed to read the type of bar code being scanned.
	Bar code symbol is unreadable.	Check the symbol to ensure it is not defaced. Try scanning test bar codes of the same bar code type. See <a href="#">Appendix C, Sample Bar Codes</a> for test bar codes.
	Bar code is out of range from the digital scanner.	Move digital scanner closer to or further from bar code.
	The symbol is not completely inside aiming pattern.	Move the symbol completely within the aiming pattern.
The digital scanner emits four short high beeps.	Battery is low.	Charge the battery. See <a href="#">Charging the Battery on page 1-8</a> .

**Table 3-1** Troubleshooting (Continued)

Problem	Possible Causes	Possible Solutions
The digital scanner emits a disconnect (short high-short low) beep sequence.	The digital scanner disconnected from the cradle because it is too far from the cradle.	Move closer to the cradle and listen for a reconnection beep (short low-short high).
	The digital scanner disconnected from the cradle because the cradle lost power or was placed in USB suspend mode.	Check power connections to the cradle, and if using a USB cable, check to make sure the host computer has not entered a power save mode.
The digital scanner emits four long low beeps after scanning a bar code.	The cradle did not complete USB initialization.	Wait several seconds and scan again.
	The incorrect host interface cable is used.	Connect the correct host interface cable.
	The interface/power cables to the cradle are loose.	Secure all cable connections.
	The digital scanner is not paired to a cradle.	Scan the PAIR bar code on the cradle connected to the host that is to receive data.
	The digital scanner disconnected.	See previous disconnect beep sequence.
	A transmission error was detected.	Ensure the cradle's communication parameters match the host's setting.
The digital scanner decodes the bar code, but does not transmit the data to the host.	The digital scanner is not paired to the host-connected interface.	Pair the digital scanner to the cradle (using the PAIR bar code on the cradle).
	The cradle is not programmed for the correct host interface.	Check digital scanner host parameters or edit options.
	The interface cable is loose.	Secure all cable connections.
	The cradle lost connection to the host.	See <a href="#">Reestablishing a Lost Connection to Host on page 1-6</a> .
The digital scanner emits five long low beeps after decoding a bar code.	A conversion error or format error occurred.	Properly configure the digital scanner's conversion parameters.

**Table 3-1** Troubleshooting (Continued)

Problem	Possible Causes	Possible Solutions
The host displays scanned data incorrectly.	The cradle's host communication parameters do not match the host's parameters.	Select the correct host.
		For RS-232, ensure the cradle's communication parameters match the host's settings.
		For a Keyboard Wedge configuration, program the system for the correct keyboard type, and turn off the CAPS LOCK key.
The digital scanner emits short high-short high- short high-long low beep sequence when it is not in use.	RS-232 receive error.	Properly program editing options (e.g., UPC-E to UPC-A conversion).
		Normal during host reset. Otherwise, ensure the digital scanner's RS-232 parity setting matches the host setting.
The digital scanner emits long low-long high beep sequence during programming.	Input error or <b>Cancel</b> bar code was scanned.	Scan the correct numeric bar codes within range for the parameter programmed.
The digital scanner emits short low-short high- short low-short high beep sequence during programming.	Out of ADF parameter storage space.	Erase all rules and re-program with shorter rules.
	Out of Synapse parameter storage space.	Scan <b>Set Synapse Defaults</b> bar code from the appropriate <i>Synapse Interface Guide</i> for cables no longer in use and re-program the digital scanner for the current host interface.
The digital scanner emits low-high-low beeps.	Clearing Code 39 buffer.	Normal when scanning the Code 39 Buffering <b>Clear Buffer</b> bar code or upon attempt to transmit an empty Code 39 buffer.
The digital scanner emits one short high beep when it is not in use.	In RS-232 mode, a <BEL> character is received.	Normal when <b>Beep on &lt;BEL&gt;</b> is enabled and the digital scanner is in RS-232 mode.
The digital scanner emits short low-short medium-short high beep sequence.	The digital scanner is powering up.	Normal when the battery is inserted.
The battery does not charge.	The cradle is outside the charging temperature range.	Charge within the recommended temperature of 32° to 104° F (0° to 40° C) nominal, 41° to 95° F (5° to 35° C) ideal.
The battery door falls off.	The digital scanner was dropped.	Snap the battery door back in to reinstall.



**NOTE** If problems still occur, contact the distributor or Motorola Enterprise Mobility Support. See [page xvii](#) for contact information.

## Technical Specifications

**Table 3-2** *Technical Specifications - Symbol DS3478 Digital Scanner*

Item	Description
Battery	Rechargeable Lithium-Ion 2200 mAh (3.7V)
Decode Capability	UPC/EAN, UPC/EAN with supplementals, Bookland EAN, JAN 8 & 13, Coupon Code, ISSN EAN, Code 128, GS1-128, ISBT 128, Code 39, Code 39 Full ASCII, Code 39 Trioptic, Code 32, Code 93, Code 11, Interleaved 2 of 5, Discrete 2 of 5, IATA 2 of 5, Codabar (NW7), MSI, Chinese 2 of 5, Matrix 2 of 5, Inverse 1D, US Postnet, US Planet, UK Postal, Japan Postal, Australia Postal, Netherlands KIX Code, USPS 4CB/One Code/Intelligent Mail, UPU FICS Postal, GS1 DataBar, Composite Codes, PDF417, MicroPDF, Data Matrix (ECC 200), Maxicode, QR Code, QR Inverse, MicroQR, Aztec, Aztec Inverse, DPM (DPM version only).
Beeper Operation	User-selectable: Enable, Disable
Beeper Volume	User-selectable: Three levels
Beeper Tone	User-selectable: Three tones
Field of View	30° +/- 2° horizontal 22.5° +/- 2° vertical
Yaw Tolerance	± 50° from nominal
Pitch Tolerance	± 60° from nominal
Roll Tolerance	± 180° from nominal
Print Contrast Minimum	25% minimum reflectance differential, measured at 650 nm.
Ambient Light Immunity	10,000 Ft Candles (107,600 Lux)
Durability	6.5 ft (2.0 m) drops to concrete
Operating Temperature	-4° to 122° F (-20° to 50° C)
Storage Temperature	-40° to 140° F (-40° to 60° C)
Charging Temperature	32° to 104° F (0° to 40° C) nominal, 41° to 95° F (5° to 35° C) ideal
Humidity	5% to 95% (non-condensing)
ESD	15 kV air discharge 8 kV contact discharge
Weight	14.6 oz (414 grams)
Dimensions:	
Height	7.34 in. (18.65 cm)
Width	4.82 in. (12.25 cm)
Depth	2.93 in. (7.43 cm)
Laser	650nm laser diode

**Table 3-2** *Technical Specifications - Symbol DS3478 Digital Scanner (Continued)*

Item	Description
Laser Classification	EN60950-1 1994 + A1:2002 + A2:2001 IEC60825-1 1993 + A1:1997 + A2:2001
Minimum Element Width	5 mil (0.127 mm)
Interfaces Supported	Keyboard Wedge, RS-232, USB, IBM 468X/469X, Wand Emulation, Scanner Emulation, Synapse, 123Scan
Radio Link	Bluetooth Class 1/Class 2 (2.4 GHz)
Electrical Safety	Certified to UL60950-1, CSA 22.2 No. 60950-1, EN60950-1/IEC60950-1
Input Transient Protection	EN301 489-1 Clause 9.4, EN301 489-17 Clause 6 Section 1
EMI	FCC Part 15 Class B, ICES-003 Class B, EN 55022 1994 A1:1995 + A2:1997, Japan VCCI

**Table 3-3** *Technical Specifications - STB 3478 Cradle*

Item	Description
Power Requirements	4.75 - 14.0 VDC
<b>Typical Current Draw</b>	
Not Charging:	105 mA @ 5V 45 mA @ 9V
Fast Rate Charge:	955 mA @ 5V 660 mA @ 9V
Slow Rate Charge:	480 mA @ 5V 345 mA @ 9V
Interfaces Supported	Keyboard Wedge, RS-232, USB, IBM 468X/469X, Wand Emulation, Scanner Emulation, Synapse
Operating Temperature	-4° to 122° F (-20° to 50° C)
Storage Temperature	-40° to 140° F (-40° to 60° C)
Charging Temperature	32° to 104° F (0° to 40° C) nominal, 41° to 95° F (5° to 35° C) ideal
Humidity	5% to 95% (non-condensing)
ESD	15 kV air discharge 8 kV contact discharge
Weight	10.5 oz (298 grams)
Dimensions:	
Height	9.5 in. (24.1 cm)
Width	4.0 in (10.2 cm)
Depth	2.9 in (7.4 cm)





Figure 3-2 illustrates the positions of the digital scanner's cradle port pins.

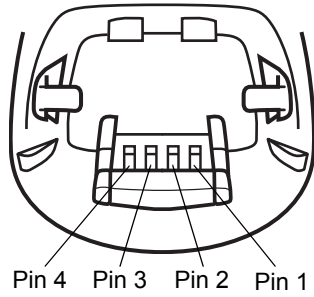

**Figure 3-2** Cradle Pin Assignments

The signal descriptions in [Table 3-5](#) apply to the connector from the digital scanner to the scanner cradle and are for reference only.

**Table 3-5** Digital Scanner to Scanner Cradle Pin-outs

Pin	Description
1	VCC
2	CRADLE_TXD
3	CRADLE_RXD
4	GND

# Chapter 4 User Preferences

## Introduction

This chapter describes each user preference feature and provides programming bar codes for selecting these features for the digital scanner.

The digital scanner ships with the settings shown in the [User Preferences Default Table on page 4-2](#) (also see [Appendix A, Standard Default Parameters](#) for all host and miscellaneous defaults). If the default values suit the requirements, programming is not necessary.

Set feature values by scanning single bar codes or short bar code sequences. The settings are stored in non-volatile memory and are preserved when you power down the digital scanner.

The digital scanner communicates with the host through the digital scanner cradle. During setup, you pair the digital scanner with a cradle, which connects to the host through one of several interfaces (see [Pairing on page 1-9](#) and the applicable host interface chapter). Each cradle can pair with up to four digital scanners.

If not using a Synapse or USB cable, select the host type (see the specific host chapter) after the digital scanner emits power-up beeps. This is only necessary upon the first power-up when connecting to a new host.

✓ **NOTE** Disconnect the power supply before changing host cables or the digital scanner may not recognize the new host.

To return all features to their default values, scan [Set All Defaults on page 4-3](#). Throughout the programming bar code menus, asterisks (\*) indicate default values.



## Scanning Sequence Examples

In most cases, scan only one bar code to set a parameter value. For example, to set the beeper tone to high, scan the **High Frequency** (beeper tone) bar code under [Beeper Tone on page 4-4](#). The digital scanner issues a fast warble beep and the LED turns green, indicating a successful parameter entry.

Other parameters, such as **Decode Session Timeout**, require scanning several bar codes. See the parameter description for this procedure.

## Errors While Scanning

Unless otherwise specified, if you make an error during a scanning sequence, re-scan the correct parameter.

## User Preferences Default Parameters

[Table 4-1](#) lists the defaults for user preference parameters. To change any option, scan the appropriate bar code(s) provided in [User Preferences on page 4-3](#).

✓ **NOTE** See [Appendix A, Standard Default Parameters](#) for all user preference, host, symbology, and miscellaneous default parameters.

**Table 4-1** *User Preferences Default Table*

Parameter	Default	Page Number
<b>User Preferences</b>		
Set Default Parameter	All Defaults	<a href="#">4-3</a>
Parameter Scanning	Enable	<a href="#">4-3</a>
Beeper Tone	Medium	<a href="#">4-4</a>
Beeper Volume	High	<a href="#">4-5</a>
Power Mode	Reduced	<a href="#">4-5</a>
Beep After Good Decode	Enable	<a href="#">4-6</a>
Picklist Mode	Disabled Always	<a href="#">4-7</a>
Decode Session Timeout	3.0 seconds	<a href="#">4-8</a>
Fuzzy 1D Decoding	Enable	<a href="#">4-8</a>
Decode Mirror Images	Never	<a href="#">4-9</a>
Connection Maintenance Interval	15 minutes	<a href="#">4-10</a>
Radio Output Power	Bluetooth Class 1	<a href="#">4-12</a>
Parameter Broadcast	Enable	<a href="#">4-12</a>
Single Point/Multipoint Operation	Single Point	<a href="#">4-13</a>

---

## User Preferences

### Set Default Parameter

Scan this bar code to return all parameters to the default values listed in [Table A-1 on page A-1](#).



**Set All Defaults**

### Parameter Scanning

To disable decoding of parameter bar codes, scan the **Disable Parameter Scanning** bar code below. Note that the digital scanner can still decode the **Set Defaults** parameter bar code. To enable decoding of parameter bar codes, either scan **Enable Parameter Scanning** or **Set All Defaults**.



**\*Enable Parameter Scanning**



**Disable Parameter Scanning**

## Beeper Tone

To select a decode beep frequency (tone), scan the **Low Frequency**, **Medium Frequency**, or **High Frequency** bar code.

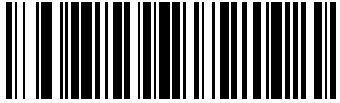

**Low Frequency**

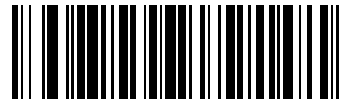

**\*Medium Frequency**

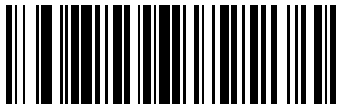

**High Frequency**

## Beeper Volume

To select a beeper volume, scan the **Low Volume**, **Medium Volume**, or **High Volume** bar code.



**Low Volume**



**Medium Volume**



**\*High Volume**

## Power Mode

This parameter determines whether or not the digital scanner enters reduced power mode after a decode attempt. When in reduced power mode, the digital scanner draws less current from its battery.



**Continuous On**



**\*Reduced Power Mode**

## Beep After Good Decode

Scan one of the following bar codes to select whether the digital scanner beeps after a good decode. If you select **Do Not Beep After Good Decode**, the beeper still operates during parameter menu scanning and indicates error conditions.



**\*Beep After Good Decode  
(Enable)**

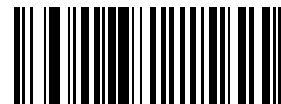

**Do Not Beep After Good Decode  
(Disable)**



## Picklist Mode

Picklist mode enables the digital scanner to decode only bar codes that are aligned under the laser crosshair. Select one of the following picklist modes for the digital scanner:

- **Disabled Always (default)** - Picklist mode is always disabled.
- **Enabled Out of Scanstand** - Picklist mode is enabled when the digital scanner is out of presentation (scanstand) mode and disabled when the digital scanner is in presentation mode.
- **Enabled Always** - Picklist mode is always enabled.



**NOTE** If you enabled [DPM Scanning on page 5-5](#), disable **Picklist Mode** when scanning a DPM bar code. Picklist performance is not guaranteed for DPM bar codes.



**\*Disabled Always**



**Enabled Out of Scanstand**



**Enabled Always**

## Decode Session Timeout

This parameter sets the maximum time decode processing continues during a scan attempt. It is programmable in 0.1 second increments from 0.5 to 9.9 seconds. The default timeout is 3.0 seconds.

To set a Decode Session Timeout, scan the bar code below. Next, scan two numeric bar codes from [Appendix D, Numeric Bar Codes](#) that correspond to the desired on time. Enter a leading zero for single digit numbers. For example, to set a Decode Session Timeout of 0.5 seconds, scan the bar code below, then scan the **0** and **5** bar codes. To correct an error or change the selection, scan **Cancel** on [page D-3](#).



**Decode Session Timeout**

## Fuzzy 1D Decoding

Enable this parameter to increase aggressiveness when decoding significantly damaged 1D symbols. Disabling this parameter reduces decode aggressiveness on such symbols, but increases decode aggressiveness on 2D symbols.



**NOTE** 123Scan does not support this option.



**\*Enable Fuzzy 1D Decoding**



**Disable Fuzzy 1D Decoding**

## Decode Mirror Images (Data Matrix Only)

Select an option for decoding mirror image Data Matrix bar codes:

- Always - decode only Data Matrix bar codes that are mirror images
- Never - do not decode Data Matrix bar codes that are mirror images
- Auto - decode both mirrored and unmirrored Data Matrix bar codes.



**\*Never**



**Always**



**Auto**

---

## Radio Communications

### Connection Maintenance Interval

When a digital scanner disconnects from a cradle due to a Link Supervision Timeout, the digital scanner immediately attempts to reconnect to the cradle for 30 seconds. If the digital scanner does not reconnect within 30 seconds, it enters low power mode. Thereafter, when you scan a bar code, the digital scanner attempts to reconnect before transmitting the data.

To guarantee that a disconnected digital scanner can reconnect when it comes back in range, the cradle reserves the connection for that digital scanner for a period of time defined by the Connection Maintenance Interval. If the cradle already supports the maximum four digital scanners, and one digital scanner disconnects, a fifth digital scanner cannot pair to the cradle during this interval. Connection Maintenance Interval options are:

- 15 minutes
- 30 minutes
- One hour
- Two hours
- Four hours
- Eight hours
- 24 hours
- Indefinitely.

### Considerations

The system administrator determines the Connection Maintenance Interval. A shorter interval allows new users to gain access to abandoned connections more quickly, but causes problems if users leave the work area for extended periods. A longer interval allows existing users to leave the work area for longer periods of time, but ties up the system for new users.

To avoid this conflict, users who are going off-shift can scan the unpair bar code on [page 4-13](#) to ignore the Connection Maintenance Interval and make the connection immediately available.

To set the Connection Maintenance Interval, select one of the following bar codes.



**\*Set Interval to 15 Minutes**



**Set Interval to 30 Minutes**

### Connection Maintenance Interval (continued)



**Set Interval to 60 Minutes**



**Set Interval to 2 Hours**



**Set Interval to 4 Hours**



**Set Interval to 8 Hours**



**Set Interval to 24 Hours**



**Set Interval to Forever**

## Radio Output Power

The Symbol DS3478 uses a Class 1 Bluetooth radio with a transmission range of up to 100m. Optionally place the radio in Class 2 operating mode to restrict the transmission range to 10m and reduce the effect of the radio on neighboring wireless systems.

Scan a bar code to select Class 1 or Class 2 operation.



**\*Bluetooth Class 1**



**Bluetooth Class 2**

## Parameter Broadcast

Enable Parameter Broadcast to broadcast all parameter bar codes scanned to all other digital scanners in the piconet. Disable this to process parameter bar codes by the individual digital scanner only, and the digital scanner ignores parameters broadcast from other digital scanners or from the cradle (e.g., parameters sent via 123Scan).



**\*Enable Parameter Broadcast**



**Disable Parameter Broadcast**

## Single Point/Multipoint Operation

The cradle supports communication from up to four digital scanners simultaneously. This multipoint mode requires an external power supply to charge the digital scanners in the cradle. To power the cradle from the interface cable (either from the USB hub or from a power supply attached to the interface cable), place the cradle in single point mode. In single point mode, only one digital scanner can connect to the cradle at a time.

- ✓ **NOTE** When operating in bus-powered mode, the cradle must turn off the Bluetooth radio to charge the digital scanner. For this reason, only charge the digital scanner paired with the cradle in the cradle. Placing another digital scanner in the cradle for charging disrupts communication with the paired digital scanner.

When setting options while in multipoint mode, allow time for the setting changes to apply to all digital scanners.

To select single point or multipoint mode, scan the appropriate bar code.



**Multipoint Mode**



**\*Single Point Mode**

## Unpair

Scan the following bar code to disconnect the digital scanner from its cradle.



**Unpairing**

- ✓ **NOTE** The *Symbol DS3478 Quick Start Guide* also includes the unpairing bar code





# Chapter 5 Decoding Preferences

## Introduction

You can program the digital scanner to perform various functions, or activate different features. This chapter describes digital scanner preference features and provides programming bar codes for selecting these features.

The digital scanner ships with the settings shown in the [Decoding Preferences Default Table on page 5-2](#) (also see [Appendix A, Standard Default Parameters](#) for all host and miscellaneous defaults). If the default values suit requirements, programming is not necessary.

To set feature values, scan a single bar code or a short bar code sequence. The settings are stored in non-volatile memory and are preserved even when the digital scanner powers down.

The digital scanner communicates with the host through the digital scanner cradle. During setup, the digital scanner is paired with a cradle, which connects to the host through one of several interfaces (see [Pairing on page 1-9](#) and the applicable host interface chapter). Each cradle can pair with up to four digital scanners.

If not using a Synapse or USB cable, select a host type (see each host chapter for specific host information) after the power-up beeps sound. This is only necessary upon the first power-up when connecting to a new host.

✓ **NOTE** Disconnect the power supply before changing host cables or the digital scanner may not recognize the new host.

To return all features to default values, scan the [Set Default Parameter on page 4-3](#). Throughout the programming bar code menus, asterisks (\*) indicate default values.



## Scanning Sequence Examples

In most cases scanning one bar code sets the parameter value. For example, to disable the decode aiming pattern, scan the **Disable Decode Aiming Pattern** bar code listed under [Decode Aiming Pattern on page 5-4](#). The digital scanner issues a fast warble beep and the LED turns green, signifying a successful parameter entry.

Other parameters require scanning several bar codes. See these parameter descriptions for this procedure.

## Errors While Scanning

Unless otherwise specified, to correct an error during a scanning sequence, just re-scan the correct parameter.

## Decoding Preferences Parameter Defaults

[Table 5-1](#) lists defaults for digital scanner preference parameters. To change any option, scan the appropriate bar code(s) provided in [Decoding Preferences on page 5-3](#).



**NOTE** See [Appendix A, Standard Default Parameters](#) for all user preference, host, symbology, and miscellaneous default parameters.

**Table 5-1** *Decoding Preferences Default Table*

Parameter	Default	Page Number
<b>Decoding Options</b>		
Focus Mode	Far Focus Note: The default value for DS3478-DP (DPM) digital scanners is Near Focus.	<a href="#">5-3</a>
Decoding Illumination	Enable	<a href="#">5-4</a>
Decode Aiming Pattern	Enable	<a href="#">5-4</a>
DPM Scanning	Enable	<a href="#">5-5</a>

---

## Decoding Preferences

The parameters in this chapter control bar code decoding characteristics.

### Focus Mode

Select the Focus Mode to control the working range of the digital scanner:

- Select **Far Focus** to optimize the digital scanner to read at its far position. Use this mode when scanning large bar codes in order to fit these bar codes in the digital scanner's field of view.
- Select **Near Focus** to optimize the digital scanner to read at its near position. Use this mode when scanning small, high-density bar codes.
- **Smart Focus** toggles the focus position after every frame. This mode is ideal for scanning a combination of small and large bar codes. Note that this mode can result in a slight loss of scanning aggressiveness as the digital scanner toggles between near and far focus.



**\*Far Focus**



**Near Focus**



**Smart Focus**



**NOTE** The default value for DS3478-DP (DPM) digital scanners is Near Focus.

## Decoding Illumination

Selecting **Enable Decoding Illumination** causes the digital scanner to flash illumination to aid decoding. Enabling illumination usually results in superior images. The effectiveness of the illumination decreases as the distance to the bar code increases.

Select **Disable Decoding Illumination** to prevent the digital scanner from using decoding illumination, typical for outdoor scanning. Disabling this option extends battery life.



**\*Enable Decoding Illumination**



**Disable Decoding Illumination**

## Decode Aiming Pattern

Select **Enable Decode Aiming Pattern** to project the aiming pattern during decoding, or **Disable Decode Aiming Pattern** to turn the aiming pattern off.



**NOTE** With [Picklist Mode on page 4-7](#) enabled, the decode aiming pattern flashes even when the Decode Aiming Pattern is disabled.



**\*Enable Decode Aiming Pattern**



**Disable Decode Aiming Pattern**

## DPM Scanning

Unlike bar codes that are typically printed on labels, a direct part mark (DPM) is a symbol that is marked directly on an item's surface for permanent identification. These symbols are marked using methods such as laser etching and dot peening (see [Figure 2-4 on page 2-6](#) for an example of a dot peened symbol). The DS3478-DP (DPM) digital reader scans these types of symbols.

- ✓ **NOTE** When the DS3478-DP digital scanner is DPM enabled, the digital scanner reads all symbols including DPM, 1D, PDF417, etc. If you don't need DPM reading, scan **Disable DPM Scanning** to ensure optimum scanner performance.

If you enable **DPM Scanning**, disable [Picklist Mode on page 4-7](#) when scanning a DPM bar code. Picklist performance is not guaranteed for DPM bar codes.

Also, if you enable DPM Scanning, the scanner behaves as if you enabled the **Data Matrix Inverse Autodetect** setting. When you disable DPM Scanning, the previous (user-selected) **Data Matrix Inverse** setting remains in effect. See [Data Matrix Inverse on page 13-71](#).

To program the DS3478-DP digital scanner for DPM reading:

1. The DS3478-DP digital scanner can not read certain bar codes in near field. To ensure the digital scanner can read all bar codes, scan **Far Focus** on [page 5-3](#).
2. If you disabled DPM scanning in the DS3478-DP digital scanner, scan **Enable DPM Scanning**.
3. Before scanning a DPM bar code, ensure that [Data Matrix on page 13-71](#) is enabled.



**\*Enable DPM Scanning**



**Disable DPM Scanning**



# Chapter 6 Keyboard Wedge Interface

---

## Introduction

This chapter provides instructions for programming the digital scanner for the keyboard wedge host interface, used to connect the digital scanner between the keyboard and host computer. The digital scanner translates the bar code data into keystrokes, and transmits the information to the host computer via the cradle interface. The host computer accepts the keystrokes as if they originated from the keyboard.

This interface adds bar code reading functionality to a system designed for manual keyboard input. In this mode the keyboard keystrokes are simply passed through.

Throughout the programming bar code menus, asterisks (\*) indicate default values.

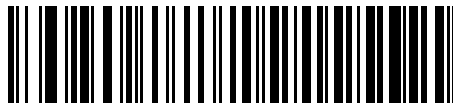

\* Indicates Default — **\*North American** — Feature/Option

## Connecting a Keyboard Wedge Interface

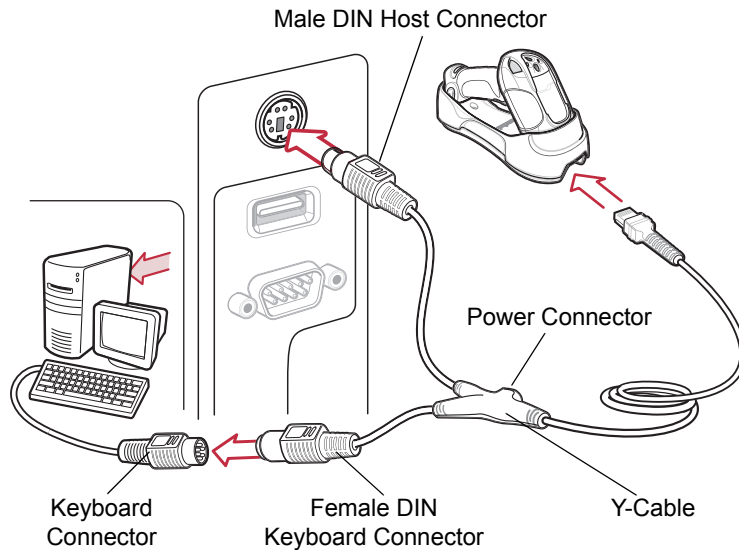

**Figure 6-1** Keyboard Wedge Interface Connection with Y-cable

To connect the keyboard wedge interface Y-cable:

1. Turn off the host computer and unplug the keyboard connector.
2. Attach the modular connector of the Y-cable to the cable interface port on the digital scanner cradle. See [Connecting the Cradle on page 1-4](#).
3. Connect the round male DIN host connector of the Y-cable to the keyboard port on the host computer.
4. Connect the round female DIN keyboard connector of the Y-cable to the keyboard connector.
5. If required, attach the optional power supply to the power connector on the Y-cable.
6. Ensure all connections are secure.
7. Turn on the host system.
8. Pair the digital scanner to the cradle by scanning the bar code on the cradle.
9. Select the keyboard wedge host type by scanning the appropriate bar code from [Keyboard Wedge Host Types on page 6-4](#).
10. To modify any other parameter options, scan the appropriate bar codes in this chapter.
11. Connect an external power supply if required.

✓ **NOTE** Interface cables vary depending on configuration. The connectors may be different from those illustrated in [Figure 6-1](#), but the steps to connect the digital scanner cradle are the same.

Disconnect the power supply before changing host cables or the digital scanner may not recognize the new host.



## Keyboard Wedge Default Parameters

[Table 6-1](#) lists the defaults for keyboard wedge host parameters. To change any option, scan the appropriate bar code(s) provided in this chapter.

✓ **NOTE** See [Appendix A, Standard Default Parameters](#) for all user preference, host, symbology, and miscellaneous default parameters.

**Table 6-1** Keyboard Wedge Host Default Table

Parameter	Default	Page Number
<b>Keyboard Wedge Host Parameters</b>		
Keyboard Wedge Host Type	IBM PC/AT& IBM PC Compatibles	<a href="#">6-4</a>
Keyboard Wedge Country Types (Country Codes)	North American	<a href="#">6-5</a>
Ignore Unknown Characters	Enable	<a href="#">6-7</a>
Keystroke Delay	0 msec (No Delay)	<a href="#">6-7</a>
Intra-Keystroke Delay	Disable	<a href="#">6-8</a>
Alternate Numeric Keypad Emulation	Disable	<a href="#">6-8</a>
Caps Lock On	Disable	<a href="#">6-9</a>
Caps Lock Override	Disable	<a href="#">6-9</a>
Convert Wedge Data	Do Not Convert Wedge Data	<a href="#">6-10</a>
Function Key Mapping	Disable	<a href="#">6-10</a>
FN1 Substitution	Disable	<a href="#">6-11</a>
Send Make and Break	Send Make and Break Scan Codes	<a href="#">6-11</a>

---

## Keyboard Wedge Parameters

### Keyboard Wedge Host Types

Select the keyboard wedge host by scanning one of the following bar codes.



**\*IBM PC/AT & IBM PC Compatibles**



**IBM AT Notebook**

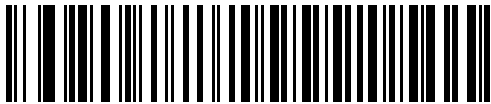

**NCR 7052**

## Keyboard Wedge Country Types (Country Codes)

Scan the bar code corresponding to the keyboard type. If your keyboard type does not appear, see [Alternate Numeric Keypad Emulation on page 6-8](#).



**\*North American**



**German Windows**

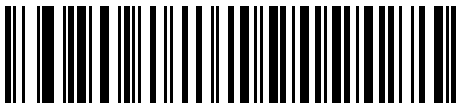

**French Windows**



**French Canadian Windows 95/98**

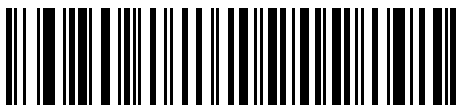

**French Canadian Windows XP/2000**



**Spanish Windows**

### Keyboard Wedge Country Types (Country Codes) (continued)

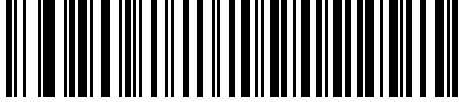

**Italian Windows**

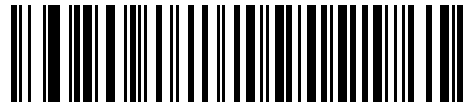

**Swedish Windows**

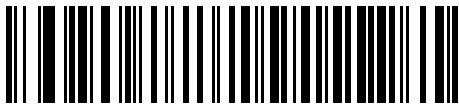

**UK English Windows**



**Japanese Windows**

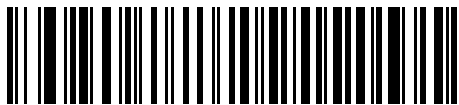

**Brazilian-Portuguese Windows**

## Ignore Unknown Characters

Unknown characters are characters the host does not recognize. Select **Send Bar Codes With Unknown Characters** to send all bar code data except for unknown characters. The digital scanner emits no error beeps. Select **Do Not Send Bar Codes With Unknown Characters** to send bar code data until the scanner encounters the first unknown character. The digital scanner emits an error beep.

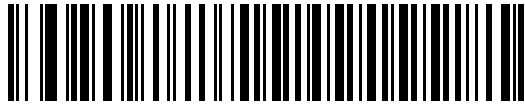

**\*Send Bar Codes with Unknown Characters  
(Enable)**



**Do Not Send Bar Codes with Unknown Characters  
(Disable)**

## Keystroke Delay

This is the delay in milliseconds between emulated keystrokes. Scan a bar code below to increase the delay when hosts require a slower data transmission.

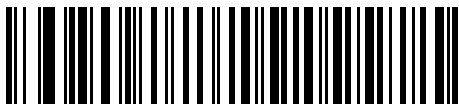

**\*0 msec (No Delay)**



**20 msec (Medium Delay)**

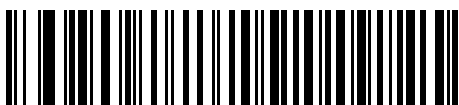

**40 msec (Long Delay)**

## Intra-Keystroke Delay

Enable Intra-Keystroke Delay to insert an additional delay between each emulated key press and release. This also sets the Keystroke Delay parameter to a minimum of 5 msec.



**Enable Intra-Keystroke Delay**



**\*Disable Intra-Keystroke Delay**

## Alternate Numeric Keypad Emulation

This allows emulation of most other country keyboard types not listed in [Keyboard Wedge Country Types \(Country Codes\) on page 6-5](#) in a Microsoft® operating system environment.



**Enable Alternate Numeric Keypad**

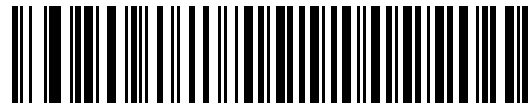

**\*Disable Alternate Numeric Keypad**

## Caps Lock On

Enable this to emulate keystrokes as if the Caps Lock key is always pressed.

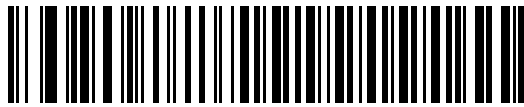

Enable Caps Lock On

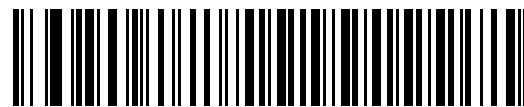

\*Disable Caps Lock On

## Caps Lock Override

For AT or AT Notebook hosts, enable this to ignore the state of the Caps Lock key and match the case (upper or lower) of the sent character. Therefore, an upper case 'A' in the bar code transmits as an upper case 'A,' and a lower case 'a' in the bar code transmits as a lower case 'a,' regardless of the state of the keyboard's Caps Lock key.

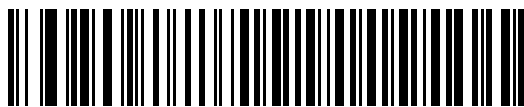

Enable Caps Lock Override

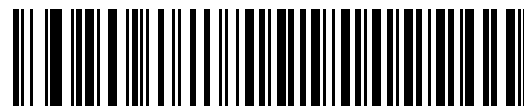

\*Disable Caps Lock Override



**NOTE** If you enabled both Caps Lock On and Caps Lock Override, Caps Lock Override takes precedence.

## Convert Wedge Data

Enable this to convert all bar code data to the selected case.

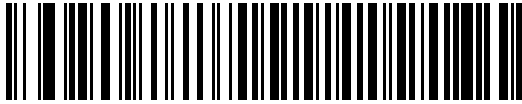

**Convert Wedge Data to Upper Case**

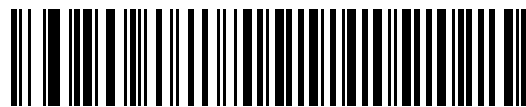

**Convert Wedge Data to Lower Case**

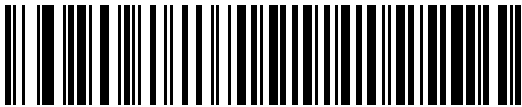

**\*Do Not Convert Wedge Data**

## Function Key Mapping

ASCII values under 32 normally transmit as control key sequences (see [Table 6-2 on page 6-14](#)). Enable this parameter to send the keys shown in bold in the table, in place of the standard key mapping. Table entries that do not have a bold entry remain the same regardless of this parameter.

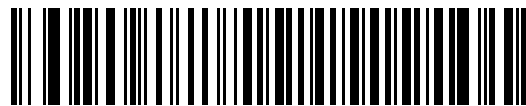

**Enable Function Key Mapping**

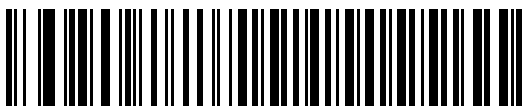

**\*Disable Function Key Mapping**



## FN1 Substitution

Enable this parameter to replace any FN1 character in a GS1-128 bar code with a user-selected keystroke. See [FN1 Substitution Values on page 14-6](#).

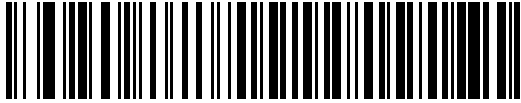

**Enable FN1 Substitution**



**\*Disable FN1 Substitution**

## Send Make and Break

Enable this to prevent sending the scan codes for releasing a key.

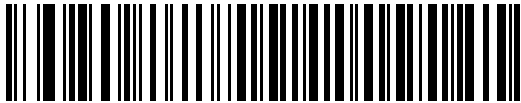

**\*Send Make and Break Scan Codes**

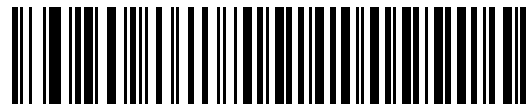

**Send Make Scan Code Only**

## Keyboard Maps

Refer to the following keyboard maps for prefix/suffix keystroke parameters. To program the prefix/suffix values, see the bar codes on [page 14-4](#).

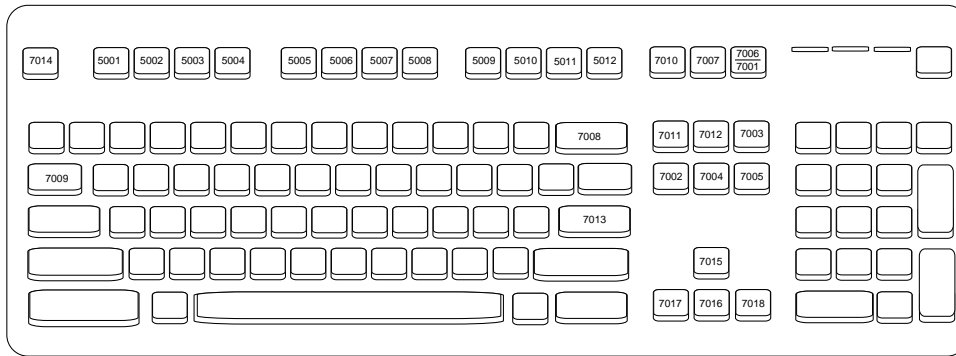

**Figure 6-2** IBM PS2 Type Keyboard

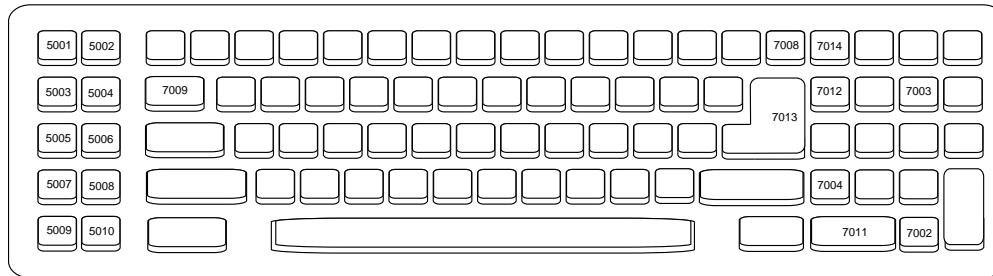

**Figure 6-3** IBM PC/AT

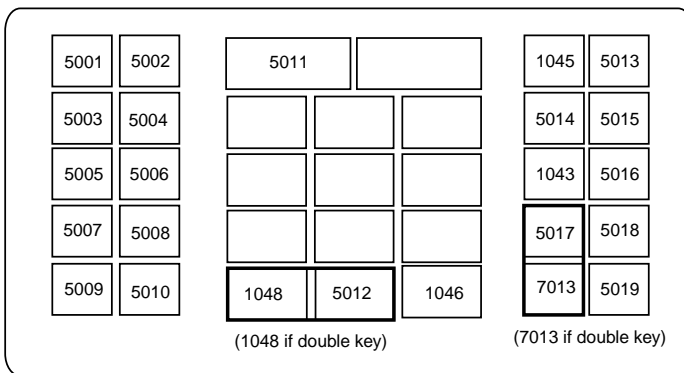

**Figure 6-4** NCR 7052 32-KEY

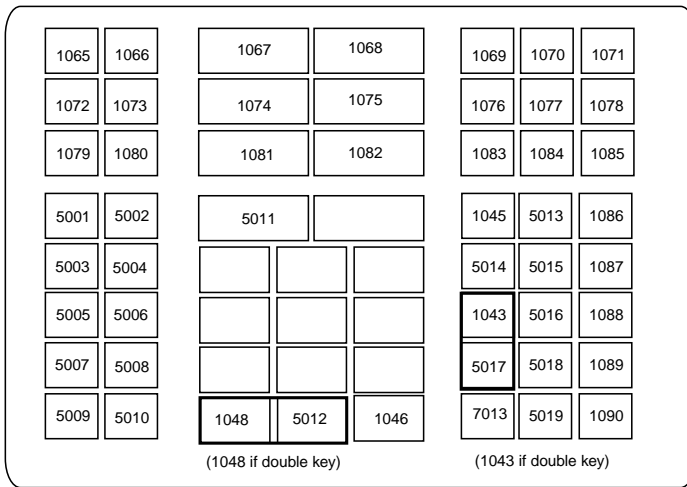

**Figure 6-5** NCR 7052 58-KEY

## ASCII Character Set

- ✓ **NOTE** Code 39 Full ASCII interprets the bar code special character (\$ + % /) preceding a Code 39 character and assigns an ASCII character value to the pair. For example, if you enable Code 39 Full ASCII and scan a **+B**, it transmits as **b**, **%J** as **?**, and **%V** as **@**. Scanning **ABC%I** outputs the keystroke equivalent of **ABC >..**

**Table 6-2** Keyboard Wedge ASCII Character Set

ASCII Value	Full ASCII Code 39 Encode Character	Keystroke
1001	\$A	CTRL A
1002	\$B	CTRL B
1003	\$C	CTRL C
1004	\$D	CTRL D
1005	\$E	CTRL E
1006	\$F	CTRL F
1007	\$G	CTRL G
1008	\$H	CTRL H/ <b>BACKSPACE</b> <sup>1</sup>
1009	\$I	CTRL I/ <b>HORIZONTAL TAB</b> <sup>1</sup>
1010	\$J	CTRL J
1011	\$K	CTRL K
1012	\$L	CTRL L
1013	\$M	CTRL M/ <b>ENTER</b> <sup>1</sup>
1014	\$N	CTRL N
1015	\$O	CTRL O
1016	\$P	CTRL P
1017	\$Q	CTRL Q
1018	\$R	CTRL R
1019	\$S	CTRL S
1020	\$T	CTRL T
1021	\$U	CTRL U

<sup>1</sup>The keystroke in bold transmits only if you enable *Function Key Mapping* on page 6-10. Otherwise, the unbolded keystroke transmits.

**Table 6-2** Keyboard Wedge ASCII Character Set (Continued)

ASCII Value	Full ASCII Code 39 Encode Character	Keystroke
1022	\$V	CTRL V
1023	\$W	CTRL W
1024	\$X	CTRL X
1025	\$Y	CTRL Y
1026	\$Z	CTRL Z
1027	%A	CTRL [ <b>/ESC</b> <sup>1</sup>
1028	%B	CTRL \
1029	%C	CTRL ]
1030	%D	CTRL 6
1031	%E	CTRL -
1032	Space	Space
1033	/A	!
1034	/B	“
1035	/C	#
1036	/D	\$
1037	/E	%
1038	/F	&
1039	/G	‘
1040	/H	(
1041	/I	)
1042	/J	*
1043	/K	+
1044	/L	,
1045	-	-
1046	.	.
1047	/O	/
1048	0	0
1049	1	1

<sup>1</sup>The keystroke in bold transmits only if you enable *Function Key Mapping on page 6-10*. Otherwise, the unbolded keystroke transmits.

**Table 6-2** Keyboard Wedge ASCII Character Set (Continued)

ASCII Value	Full ASCII Code 39 Encode Character	Keystroke
1050	2	2
1051	3	3
1052	4	4
1053	5	5
1054	6	6
1055	7	7
1056	8	8
1057	9	9
1058	/Z	:
1059	%F	;
1060	%G	<
1061	%H	=
1062	%I	>
1063	%J	?
1064	%V	@
1065	A	A
1066	B	B
1067	C	C
1068	D	D
1069	E	E
1070	F	F
1071	G	G
1072	H	H
1073	I	I
1074	J	J
1075	K	K
1076	L	L
1077	M	M

<sup>1</sup>The keystroke in bold transmits only if you enable *Function Key Mapping on page 6-10*. Otherwise, the unbolded keystroke transmits.

**Table 6-2** Keyboard Wedge ASCII Character Set (Continued)

ASCII Value	Full ASCII Code 39 Encode Character	Keystroke
1078	N	N
1079	O	O
1080	P	P
1081	Q	Q
1082	R	R
1083	S	S
1084	T	T
1085	U	U
1086	V	V
1087	W	W
1088	X	X
1089	Y	Y
1090	Z	Z
1091	%K	[
1092	%L	\
1093	%M	]
1094	%N	^
1095	%O	_
1096	%W	'
1097	+A	<b>a</b>
1098	+B	<b>b</b>
1099	+C	<b>c</b>
1100	+D	<b>d</b>
1101	+E	<b>e</b>
1102	+F	<b>f</b>
1103	+G	<b>g</b>
1104	+H	<b>h</b>
1105	+I	<b>i</b>

<sup>1</sup>The keystroke in bold transmits only if you enable *Function Key Mapping on page 6-10*. Otherwise, the unbolded keystroke transmits.

**Table 6-2** Keyboard Wedge ASCII Character Set (Continued)

ASCII Value	Full ASCII Code 39 Encode Character	Keystroke
1106	+J	j
1107	+K	k
1108	+L	l
1109	+M	m
1110	+N	n
1111	+O	o
1112	+P	p
1113	+Q	q
1114	+R	r
1115	+S	s
1116	+T	t
1117	+U	u
1118	+V	v
1119	+W	w
1120	+X	x
1121	+Y	y
1122	+Z	z
1123	%P	{
1124	%Q	
1125	%R	}
1126	%S	~

<sup>1</sup>The keystroke in bold transmits only if you enable *Function Key Mapping* on page 6-10. Otherwise, the unbolded keystroke transmits.

**Table 6-3** Keyboard Wedge ALT Key Character Set

ALT Keys	Keystroke
2065	ALT A
2066	ALT B
2067	ALT C
2068	ALT D
2069	ALT E



**Table 6-3** Keyboard Wedge ALT Key Character Set (Continued)

ALT Keys	Keystroke
2070	ALT F
2071	ALT G
2072	ALT H
2073	ALT I
2074	ALT J
2075	ALT K
2076	ALT L
2077	ALT M
2078	ALT N
2079	ALT O
2080	ALT P
2081	ALT Q
2082	ALT R
2083	ALT S
2084	ALT T
2085	ALT U
2086	ALT V
2087	ALT W
2088	ALT X
2089	ALT Y
2090	ALT Z

**Table 6-4** Keyboard Wedge GUI Key Character Set

GUI Keys	Keystrokes
3000	Right Control Key
3048	GUI 0
3049	GUI 1
3050	GUI 2
3051	GUI 3
3052	GUI 4
3053	GUI 5

**Table 6-4** Keyboard Wedge GUI Key Character Set (Continued)

GUI Keys	Keystrokes
3054	GUI 6
3055	GUI 7
3056	GUI 8
3057	GUI 9
3065	GUI A
3066	GUI B
3067	GUI C
3068	GUI D
3069	GUI E
3070	GUI F
3071	GUI G
3072	GUI H
3073	GUI I
3074	GUI J
3075	GUI K
3076	GUI L
3077	GUI M
3078	GUI N
3079	GUI O
3080	GUI P
3081	GUI Q
3082	GUI R
3083	GUI S
3084	GUI T
3085	GUI U
3086	GUI V
3087	GUI W
3088	GUI X
3089	GUI Y
3090	GUI Z

**Table 6-5** *Keyboard Wedge F Key Character Set*

<b>F Keys</b>	<b>Keystroke</b>
5001	F1
5002	F2
5003	F3
5004	F4
5005	F5
5006	F6
5007	F7
5008	F8
5009	F9
5010	F10
5011	F11
5012	F12
5013	F13
5014	F14
5015	F15
5016	F16
5017	F17
5018	F18
5019	F19
5020	F20
5021	F21
5022	F22
5023	F23
5024	F24

**Table 6-6** *Keyboard Wedge Numeric Keypad Character Set*

<b>Numeric Keypad</b>	<b>Keystroke</b>
6042	*
6043	+
6044	undefined
6045	-
6046	.
6047	/
6048	0
6049	1
6050	2
6051	3
6052	4
6053	5
6054	6
6055	7
6056	8
6057	9
6058	Enter
6059	Num Lock

**Table 6-7** *Keyboard Wedge Extended Keypad Character Set*

<b>Extended Keypad</b>	<b>Keystroke</b>
7001	Break
7002	Delete
7003	Pg Up
7004	End
7005	Pg Dn
7006	Pause
7007	Scroll Lock
7008	Backspace
7009	Tab
7010	Print Screen
7011	Insert
7012	Home
7013	Enter
7014	Escape
7015	Up Arrow
7016	Dn Arrow
7017	Left Arrow
7018	Right Arrow



# Chapter 7 RS-232 Interface

---

## Introduction

This chapter provides instructions for programming the digital scanner to interface with an RS-232 host. Use the RS-232 interface to attach the digital scanner cradle to point-of-sale devices, host computers, or other devices with an available RS-232 port (i.e., COM port).

If your host does not appear in [Table 7-2](#), set the communication parameters to match the host device. Refer to the documentation for the host device.

- ✓ **NOTE** This digital scanner uses TTL RS-232 signal levels, which interface with most system architectures. For system architectures requiring RS-232C signal levels, Motorola offers different cables providing the TTL to RS-232C conversion. Contact Motorola Enterprise Mobility Support for more information. See [page xvii](#) for contact information.

Throughout the bar code menus, asterisks (\*) indicate default values.

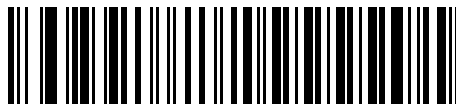

\* Indicates Default      \*Baud Rate 9600      Feature/Option

## Connecting an RS-232 Interface

Connect the digital scanner cradle directly to the host computer.

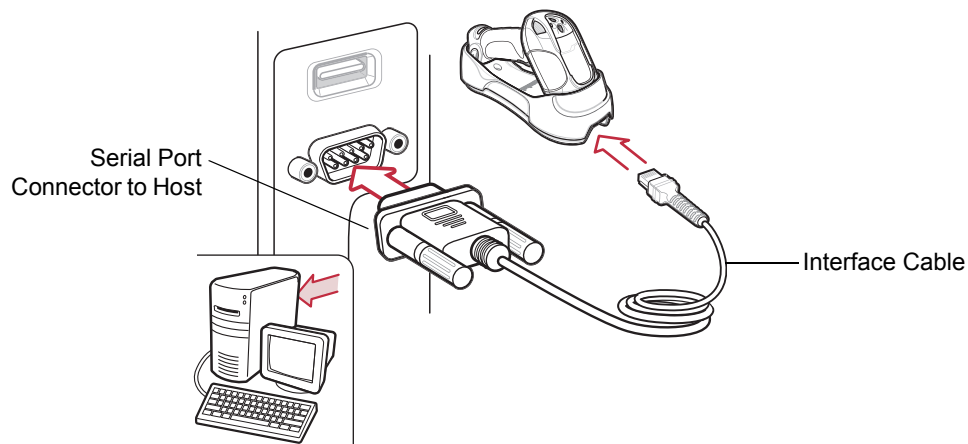

**Figure 7-1** RS-232 Direct Connection

✓ **NOTE** Interface cables vary depending on configuration. The connectors may be different from those illustrated in [Figure 7-1](#), but the steps to connect the digital scanner cradle are the same.

Disconnect the power supply before changing host cables or the digital scanner may not recognize the new host.

1. Attach the modular connector of the RS-232 interface cable to the cable interface port on the digital scanner cradle. See [Connecting the Cradle on page 1-4](#).
2. Connect the other end of the RS-232 interface cable to the serial port on the host computer.
3. Connect the power supply to the serial connector end of the RS-232 interface cable, then plug the power supply to an appropriate outlet, or connect an external power supply to the cradle.
4. Ensure all connections are secure.
5. Pair the digital scanner to the cradle by scanning the bar code on the cradle.
6. Select the RS-232 host type by scanning the appropriate bar code from [RS-232 Host Types on page 7-6](#).
7. To modify any other parameter options, scan the appropriate bar codes in this chapter.



## RS-232 Default Parameters

[Table 7-1](#) lists the defaults for RS-232 host parameters. To change any option, scan the appropriate bar code(s) provided in the parameter descriptions section beginning on [page 7-4](#).

✓ **NOTE** See [Appendix A, Standard Default Parameters](#) for all user preference, host, symbology, and miscellaneous default parameters.

**Table 7-1** RS-232 Host Default Table

Parameter	Default	Page Number
<b>RS-232 Host Parameters</b>		
RS-232 Host Types	Standard RS-232	<a href="#">7-6</a>
Baud Rate	9600	<a href="#">7-7</a>
Parity	None	<a href="#">7-9</a>
Check Receive Errors	Enable	<a href="#">7-10</a>
Stop Bit Select	1 Stop Bit	<a href="#">7-10</a>
Data Bits	8-Bit	<a href="#">7-11</a>
Hardware Handshaking	None	<a href="#">7-11</a>
Software Handshaking	None	<a href="#">7-13</a>
Host Serial Response Time-out	Minimum: 2 sec	<a href="#">7-15</a>
RTS Line State	Host: Low RTS	<a href="#">7-16</a>
Beep on <BEL>	Disable	<a href="#">7-11</a>
Intercharacter Delay	Minimum: 0 msec	<a href="#">7-17</a>
Nixdorf Beep/LED Options	Normal Operation	<a href="#">7-18</a>
Ignore Unknown Characters	Send Bar Code	<a href="#">7-19</a>

## RS-232 Host Parameters

Various RS-232 host types use their own parameter default settings. Selecting the host type sets the parameter defaults listed in [Table 7-2](#).

**Table 7-2** Terminal Specific RS-232

Parameter	Standard RS-232 (Default)	ICL	Wincor-Nixdorf Mode A	Wincor-Nixdorf Mode B	Olivetti	Omron	OPOS/JPOS	Fujitsu
Transmit Code ID	No	Yes	Yes	Yes	Yes	Yes	Yes	Yes
Data Transmission Format	Data as is	Data/Suffix	Data/Suffix	Data/Suffix	Prefix/Data/Suffix	Data/Suffix	Data/Suffix	Data/Suffix
Suffix	CR/LF (7013)	CR (1013)	CR (1013)	CR (1013)	ETX (1002)	CR (1013)	CR (1013)	CR (1013)
Baud Rate	9600	9600	9600	9600	9600	9600	9600	9600
Parity	None	Even	Odd	Odd	Even	None	Odd	None
Hardware Handshaking	None	RTS/CTS Option 3	RTS/CTS Option 3	RTS/CTS Option 3	None	None	RTS/CTS Option 3	None
Software Handshaking	None	None	None	None	Ack/Na k	None	None	None
Serial Response Time-out	2 Sec.	9.9 Sec.	9.9 Sec.	9.9 Sec.	9.9 Sec.	9.9 Sec.	9.9 Sec.	2 Sec.
Stop Bit Select	One	One	One	One	One	One	One	One
ASCII Format	8-Bit	8-Bit	8-Bit	8-Bit	7-Bit	8-Bit	8-Bit	8-Bit
Beep On <BEL>	Disable	Disable	Disable	Disable	Disable	Disable	Disable	Disable
RTS Line State	Low	High	Low	Low = No data to send	Low	High	Low = No data to send	Low
Prefix	None	None	None	None	STX (1003)	None	None	None

**\*In the Nixdorf Mode B or OPOS/JPOS, if CTS is low, scanning is disabled. When CTS is high, scanning is enabled.**

**\*\*If you scan Nixdorf Mode B or OPOS/JPOS without connecting the digital scanner to the proper host, it may appear unable to scan. If this happens, scan a different RS-232 host type within 5 seconds of cycling power to the digital scanner.**



## RS-232 Host Types

To select an RS-232 host type, scan one of the following bar codes.

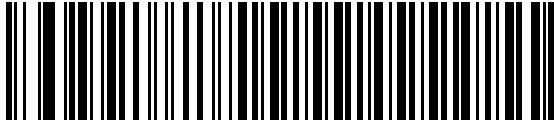

**\*Standard RS-232**

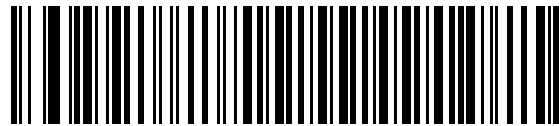

**ICL RS-232**

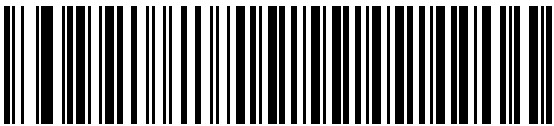

**Wincor-Nixdorf RS-232 Mode A**



**Wincor-Nixdorf RS-232 Mode B**



**Olivetti ORS4500**

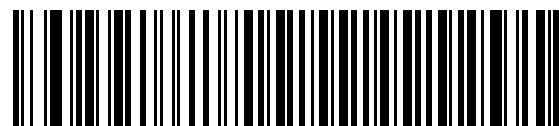

**Omron**

## RS-232 Host Types (continued)



OPOS/JPOS

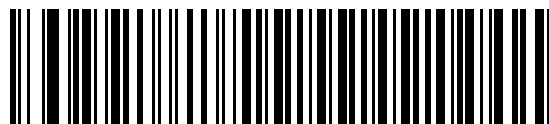

Fujitsu RS-232

## Baud Rate

Baud rate is the number of bits of data transmitted per second. Set the digital scanner's baud rate to match the baud rate setting of the host device. Otherwise, data may not reach the host device or may reach it in distorted form.

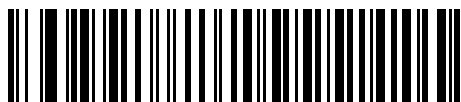

Baud Rate 600



Baud Rate 1200

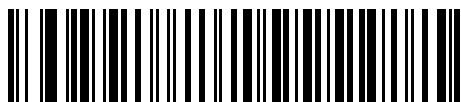

Baud Rate 2400



Baud Rate 4800

### Baud Rate (continued)

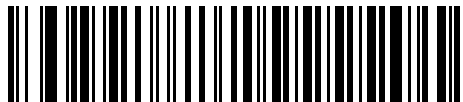

**\*Baud Rate 9600**



**Baud Rate 19,200**

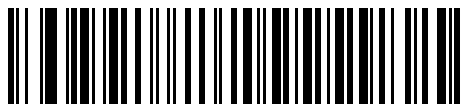

**Baud Rate 38,400**

## Parity

A parity check bit is the most significant bit of each ASCII coded character. Select the parity type according to host device requirements.

- Select **Odd** parity to set the parity bit value to 0 or 1, based on data, to ensure that the coded character contains an odd number of 1 bits.
- Select **Even** parity to set the parity bit value to 0 or 1, based on data, to ensure that the coded character contains an even number of 1 bits.
- Select **Mark** parity and the parity bit is always 1.
- Select **Space** parity and the parity bit is always 0.
- Select **None** when no parity bit is required.

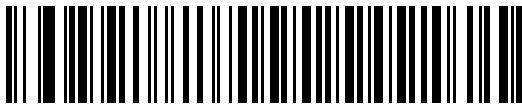

**Odd**



**Even**

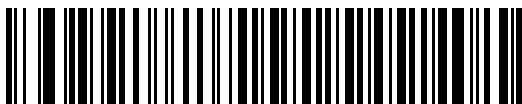

**Mark**



**Space**

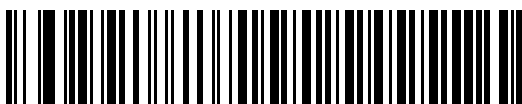

**\*None**

## Check Receive Errors

Select whether or not to check the parity, framing, and overrun of received characters. The parity value of received characters is verified against the parity parameter selected previously.



**\*Check For Received Errors  
(Enable)**



**Do Not Check For Received Errors  
(Disable)**

## Stop Bit Select

The stop bit(s) at the end of each transmitted character marks the end of transmission of one character and prepares the receiving device for the next character in the serial data stream. Select the number of stop bits (one or two) based on the number the receiving terminal is programmed to accommodate. Set the number of stop bits to match host device requirements.



**\*1 Stop Bit**



**2 Stop Bits**



## Data Bits

This parameter allows the digital scanner to interface with devices requiring a 7-bit or 8-bit ASCII protocol.

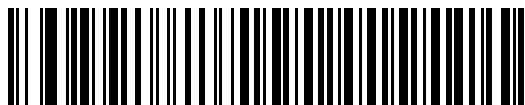

7-Bit



\*8-Bit

## Hardware Handshaking

The data interface consists of an RS-232 port designed to operate either with or without the hardware handshaking lines *Request to Send* (RTS) and *Clear to Send* (CTS).

Disable Standard RTS/CTS handshaking to transmit scan data as it becomes available. Enable Standard RTS/CTS handshaking to transmit scan data according to the following sequence:

- The digital scanner reads the CTS line for activity. If CTS is asserted, the digital scanner waits up to the Host Serial Response Time-out for the host to de-assert the CTS line. If the CTS line is still asserted after the Host Serial Response Time-out expires (default), the digital scanner sounds a transmit error and discards any scanned data.
- When the CTS line is de-asserted, the digital scanner asserts the RTS line and waits up to the Host Serial Response Time-out for the host to assert CTS. When the host asserts CTS, the digital scanner transmits data. If the CTS line is still de-asserted after Host Serial Response Time-out expires (default), the digital scanner sounds a transmission error and discards the data.
- When data transmission completes, the digital scanner de-asserts RTS 10 msec after sending the last character.
- The host responds by de-asserting CTS. The digital scanner checks for a de-asserted CTS upon the next data transmission.

During data transmission, the CTS line should be asserted. If CTS is de-asserted for more than 50 ms between characters, the digital scanner aborts transmission, sounds a transmission error, and discards the data.

If this communications sequence fails, the digital scanner issues an error indication and discards the data. Rescan the data.

If hardware handshaking and software handshaking are both enabled, hardware handshaking takes precedence.

✓ **NOTE** The DTR signal is jumpered (set) to the active state.

## Hardware Handshaking (continued)

Scan a bar code to select one of the following hardware handshaking options:

- **None** - Scan the bar code below if no hardware handshaking is desired.
- **Standard RTS/CTS** - Scan the bar code below to select Standard RTS/CTS hardware handshaking.
- **RTS/CTS Option 1** - The digital scanner asserts RTS before transmitting and ignores the state of CTS. The digital scanner de-asserts RTS when the transmission completes.
- **RTS/CTS Option 2** - RTS is always high or low (user-programmed logic level). However, the digital scanner waits for CTS to be asserted before transmitting data. If CTS is not asserted within Host Serial Response Time-out (default), the digital scanner issues an error indication and discards the data.
- **RTS/CTS Option 3** - The digital scanner asserts RTS before data transmission, regardless of the state of CTS. The digital scanner waits up to Host Serial Response Time-out (default) for CTS to be asserted. If CTS is not asserted during this time, the digital scanner issues an error indication and discards the data. The digital scanner de-asserts RTS when transmission completes.

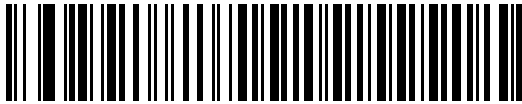

**\*None**

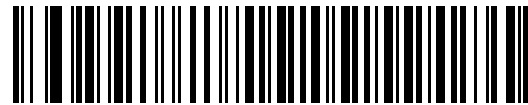

**Standard RTS/CTS**

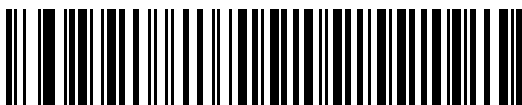

**RTS/CTS Option 1**

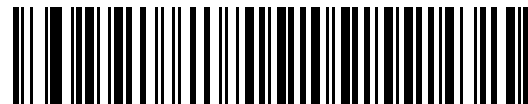

**RTS/CTS Option 2**



**RTS/CTS Option 3**

## Software Handshaking

This parameter offers control of the data transmission process in addition to, or instead of, that offered by hardware handshaking. There are five options.

If software handshaking and hardware handshaking are both enabled, hardware handshaking takes precedence.

### None

Select this option to transmit data immediately. No response is expected from the host.

### ACK/NAK

If you select this option, after transmitting data, the digital scanner expects either an ACK or NAK response from the host. When the scanner receives a NAK, it transmits the same data again and waits for either an ACK or NAK. After three unsuccessful attempts to send data after the scanner receives NAKs, the scanner issues an error indication and discards the data.

The digital scanner waits up to the programmable Host Serial Response Time-out to receive an ACK or NAK. If the digital scanner does not get a response in this time, it issues an error indication and discards the data. There are no retries when a time-out occurs.

### ENQ

If you select this option, the digital scanner waits for an ENQ character from the host before transmitting data. If it does not receive an ENQ within the Host Serial Response Time-out, the digital scanner issues an error indication and discards the data. The host must transmit an ENQ character at least every Host Serial Response Time-out to prevent transmission errors.

### ACK/NAK with ENQ

This combines the two previous options. For re-transmissions of data, due to a NAK from the host, an additional ENQ is not required.

### XON/XOFF

An XOFF character turns the digital scanner transmission off until the digital scanner receives an XON character. There are two situations for XON/XOFF:

- The digital scanner receives an XOFF before it has data to send. When the digital scanner has data to send, it waits up to Host Serial Response Time-out for an XON character before transmission. If it does not receive the XON within this time, the digital scanner issues an error indication and discards the data.
- The digital scanner receives an XOFF during a transmission. Data transmission then stops after sending the current byte. When the digital scanner receives an XON character, it sends the rest of the data message. The digital scanner waits up to 30 seconds for the XON.

### Software Handshaking (continued)



**\*None**

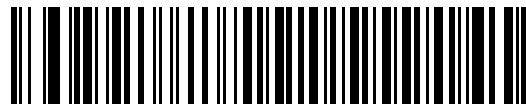

**ACK/NAK**

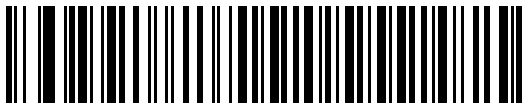

**ENQ**

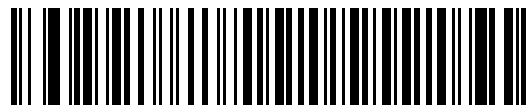

**ACK/NAK with ENQ**

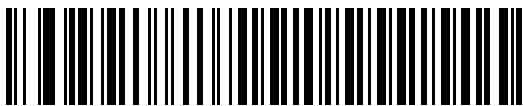

**XON/XOFF**

## Host Serial Response Time-out

This parameter specifies how long the digital scanner waits for an ACK, NAK, or CTS before determining that a transmission error occurred. This only applies when in one of the ACK/NAK software handshaking modes, or RTS/CTS hardware handshaking mode.

✓ **NOTE** This parameter does not apply to the Wincor-Nixdorf RS-232 Mode A/B and the OPOS/JPOS host types.

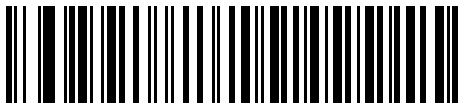

**\*Minimum: 2 sec**



**Low: 2.5 Sec**

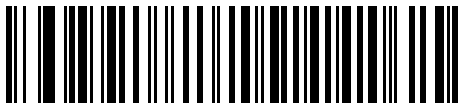

**Medium: 5 Sec**



**High: 7.5 Sec**

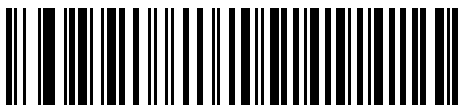

**Maximum: 9.9 Sec**

## RTS Line State

This parameter sets the idle state of the Serial Host RTS line. Scan a bar code below to select the **Low RTS** or **High RTS** line state.

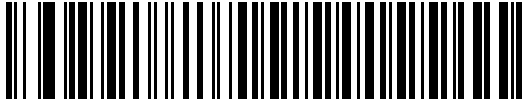

\*Host: Low RTS



Host: High RTS

## Beep on <BEL>

### Single Point Mode Only

If you enable this parameter, the digital scanner issues a beep when it detects a <BEL> character on the RS-232 serial line. <BEL> indicates an illegal entry or other important event.



**NOTE** This parameter is not supported in Multipoint mode.

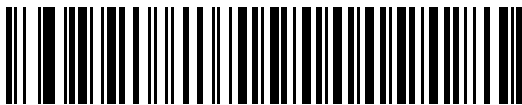

Beep On <BEL> Character  
(Enable)



\*Do Not Beep On <BEL> Character  
(Disable)

## Intercharacter Delay

This parameter specifies the intercharacter delay inserted between character transmissions.



**\*Minimum: 0 msec**

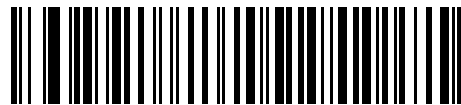

**Low: 25 msec**

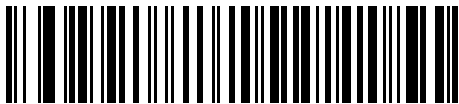

**Medium: 50 msec**



**High: 75 msec**

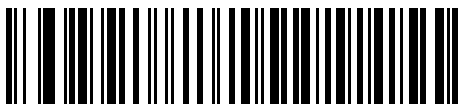

**Maximum: 99 msec**

## Nixdorf Mode A/B and OPOS/JPOS Beep/LED Options

If you selected Nixdorf Mode A, Nixdorf Mode B, or OPOS/JPOS, this parameter indicates when the digital scanner beeps and turns on its LED after a decode.

✓ **NOTE** The **Beep/LED After CTS Pulse** option is not valid when Nixdorf Mode A is selected.



**\*Normal Operation**  
**(Beep/LED Immediately After Decode)**

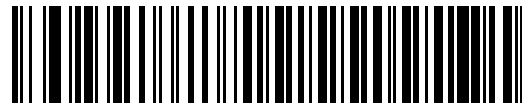

**Beep/LED After Transmission**



**Beep/LED After CTS Pulse**



## Ignore Unknown Characters

Unknown characters are characters the host does not recognize. Select **Send Bar Codes with Unknown Characters** to send all bar code data except for unknown characters. The digital scanner issues no error beeps. Select **Do Not Send Bar Codes With Unknown Characters** to send bar code data up to the first unknown character. The digital scanner issues an error beep.

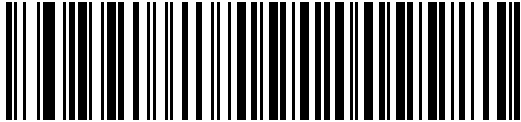

**\*Send Bar Code with Unknown Characters  
(Enable)**

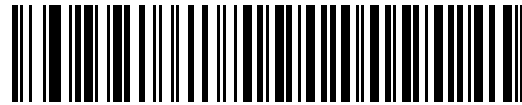

**Do Not Send Bar Codes with Unknown Characters  
(Disable)**

## ASCII Character Set

Assign the values in [Table 7-4](#) as prefixes or suffixes for ASCII character data transmission.

**Table 7-4** RS-232 ASCII Character Set

ASCII Value	Full ASCII Code 39 Encode Character	ASCII Character
1000	%U	NUL
1001	\$A	SOH
1002	\$B	STX
1003	\$C	ETX
1004	\$D	EOT
1005	\$E	ENQ
1006	\$F	ACK
1007	\$G	BELL
1008	\$H	BCKSPC
1009	\$I	HORIZ TAB
1010	\$J	LF/NW LN
1011	\$K	VT
1012	\$L	FF
1013	\$M	CR/ENTER
1014	\$N	SO
1015	\$O	SI
1016	\$P	DLE
1017	\$Q	DC1/XON
1018	\$R	DC2
1019	\$S	DC3/XOFF
1020	\$T	DC4
1021	\$U	NAK
1022	\$V	SYN
1023	\$W	ETB
1024	\$X	CAN
1025	\$Y	EM
1026	\$Z	SUB

**Table 7-4** RS-232 ASCII Character Set (Continued)

ASCII Value	Full ASCII Code 39 Encode Character	ASCII Character
1027	%A	ESC
1028	%B	FS
1029	%C	GS
1030	%D	RS
1031	%E	US
1032	Space	Space
1033	/A	!
1034	/B	"
1035	/C	#
1036	/D	\$
1037	/E	%
1038	/F	&
1039	/G	'
1040	/H	(
1041	/I	)
1042	/J	*
1043	/K	+
1044	/L	,
1045	-	-
1046	.	.
1047	/O	/
1048	0	0
1049	1	1
1050	2	2
1051	3	3
1052	4	4
1053	5	5
1054	6	6
1057	7	7
1056	8	8

**Table 7-4** RS-232 ASCII Character Set (Continued)

ASCII Value	Full ASCII Code 39 Encode Character	ASCII Character
1057	9	9
1058	/Z	:
1059	%F	;
1060	%G	<
1061	%H	=
1062	%I	>
1063	%J	?
1064	%V	@
1065	A	A
1066	B	B
1067	C	C
1068	D	D
1069	E	E
1070	F	F
1071	G	G
1072	H	H
1073	I	I
1074	J	J
1075	K	K
1076	L	L
1077	M	M
1078	N	N
1079	O	O
1080	P	P
1081	Q	Q
1082	R	R
1083	S	S
1084	T	T
1085	U	U
1086	V	V

**Table 7-4** RS-232 ASCII Character Set (Continued)

ASCII Value	Full ASCII Code 39 Encode Character	ASCII Character
1087	W	W
1088	X	X
1089	Y	Y
1090	Z	Z
1091	%K	[
1092	%L	\
1093	%M	]
1094	%N	^
1095	%O	_
1096	%W	`
1097	+A	a
1098	+B	b
1099	+C	c
1100	+D	d
1101	+E	e
1102	+F	f
1103	+G	g
1104	+H	h
1105	+I	i
1106	+J	j
1107	+K	k
1108	+L	l
1109	+M	m
1110	+N	n
1111	+O	o
1112	+P	p
1113	+Q	q
1114	+R	r
1115	+S	s
1116	+T	t

**Table 7-4** RS-232 ASCII Character Set (Continued)

ASCII Value	Full ASCII Code 39 Encode Character	ASCII Character
1117	+U	u
1118	+V	v
1119	+W	w
1120	+X	x
1121	+Y	y
1122	+Z	z
1123	%P	{
1124	%Q	
1125	%R	}
1126	%S	~
1127		Undefined
7013		ENTER

# Chapter 8 USB Interface

## Introduction

This chapter provides instructions for programming the digital scanner to interface with a USB host. The digital scanner cradle connects directly to a USB host, or a powered USB hub. The USB host can power the cradle and recharge the digital scanner battery, but this charging method has limitations. See [Using the Host to Supply Power on page 1-5](#).

Throughout the programming bar code menus, asterisks (\*) indicate default values.



## Connecting a USB Interface

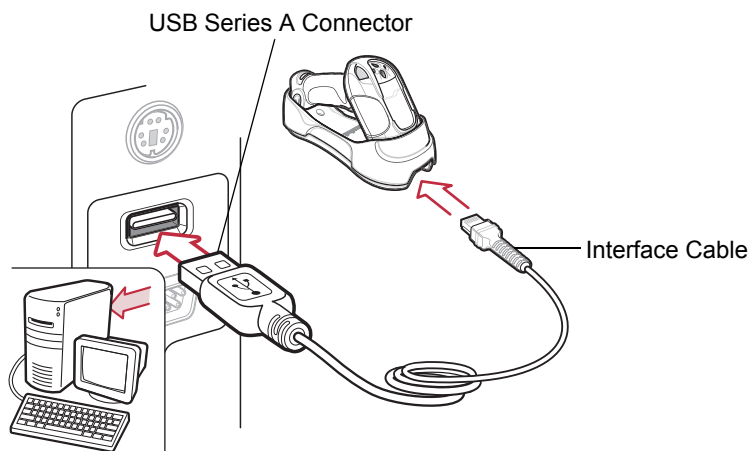

Figure 8-1 USB Connection

The digital scanner cradle connects with USB-capable hosts including:

- Desktop PCs and notebooks
- Apple™ iMacs, Power Mac G4s and G5s, iBooks (North America only), PowerBooks
- IBM SurePOS terminals
- Sun, IBM, and other network computers that support more than one keyboard.

The following operating systems support the digital scanner through USB:

- Windows® 98, 2000, ME, XP
- Mac OS 8.5 and above
- IBM 4690 OS.

The digital scanner cradle also interfaces with other USB hosts which support USB Human Interface Devices (HID). For more information on USB technology, hosts, and peripheral devices, visit <http://www.symbol.com/usb>.

To connect the digital scanner cradle to a USB host:

1. Attach the modular connector of the USB interface cable to the cable interface port on the digital scanner. See [Connecting the Cradle on page 1-4](#).
2. Plug the series A connector into the USB host or hub, or plug the Plus Power connector into an available port of the IBM SurePOS terminal.
3. Ensure all connections are secure.
4. Pair the digital scanner to the cradle by scanning the bar code on the cradle.
5. Select the USB device type by scanning the appropriate bar code from [USB Device Type on page 8-4](#).
6. On first installation when using Windows, the software displays a prompt to select or install the Human Interface Device driver. To install this driver, provided by Windows, click **Next** through all the choices and click **Finished** on the last choice. The digital scanner powers up during this installation.
7. To modify any other parameter options, scan the appropriate bar codes in this chapter.
8. Connect an external power supply if required.

✓ **NOTE** Interface cables vary depending on configuration. The connectors may be different from those illustrated in [Figure 8-1](#), but the steps to connect the digital scanner cradle are the same.

Disconnect the power supply before changing host cables or the digital scanner may not recognize the new host.

If problems occur, see [Troubleshooting on page 3-2](#).



## USB Default Parameters

*Table 8-1* lists the defaults for USB host parameters. To change any option, scan the appropriate bar code(s) provided in the parameter descriptions section beginning on [page 8-4](#).

✓ **NOTE** See [Appendix A, Standard Default Parameters](#) for all user preference, host, symbology, and miscellaneous default parameters.

**Table 8-1** *USB Host Default Table*

Parameter	Default	Page Number
<b>USB Host Parameters</b>		
USB Device Type	HID Keyboard Emulation	<a href="#">8-4</a>
USB Country Keyboard Types (Country Codes)	North American	<a href="#">8-5</a>
USB Keystroke Delay	No Delay (0 msec)	<a href="#">8-7</a>
USB Caps Lock Override	Disable	<a href="#">8-7</a>
USB Ignore Unknown Characters	Enable	<a href="#">8-8</a>
Emulate Keypad	Disable	<a href="#">8-8</a>
USB Keyboard FN1 Substitution	Disable	<a href="#">8-9</a>
Function Key Mapping	Disable	<a href="#">8-9</a>
Simulated Caps Lock	Disable	<a href="#">8-10</a>
Convert Case	No Case Conversion	<a href="#">8-10</a>

---

## USB Host Parameters

### USB Device Type

Select the desired USB device type.



**NOTE** When changing USB device types, the digital scanner disconnects and reconnects as the cradle re-enumerates on the USB bus.



**\*HID Keyboard Emulation**



**IBM Table Top USB**

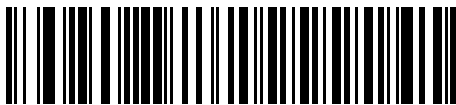

**IBM Hand-Held USB**

## USB Country Keyboard Types (Country Codes)

Scan the bar code corresponding to the keyboard type. This setting applies only to the USB HID Keyboard Emulation device.

- ✓ **NOTE** When changing USB Country Keyboard Types, the digital scanner disconnects and reconnects as the cradle re-enumerates on the USB bus.

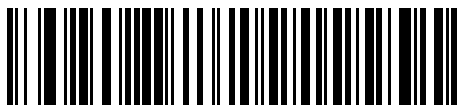

**\*North American Standard USB Keyboard**



**German Windows**

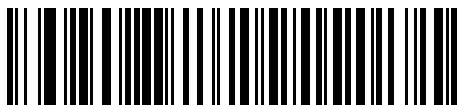

**French Windows**



**French Canadian Windows 95/98**



**French Canadian Windows 2000/XP**

## USB Country Keyboard Types (Country Codes) (continued)

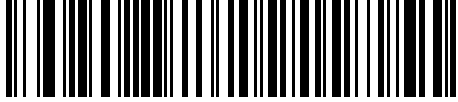

**Spanish Windows**

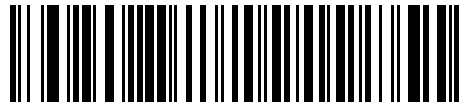

**Italian Windows**

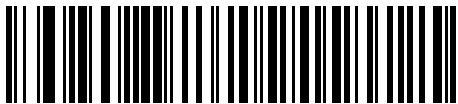

**Swedish Windows**



**UK English Windows**

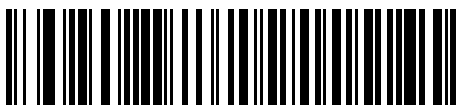

**Japanese Windows (ASCII)**

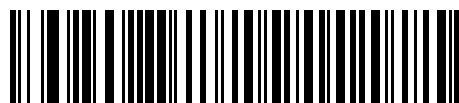

**Brazilian-Portuguese Windows**

## USB Keystroke Delay

This parameter sets the delay, in milliseconds, between emulated keystrokes. Scan a bar code below to increase the delay when hosts require slower data transmission.



**\*No Delay (0 msec)**



**Medium Delay (20 msec)**

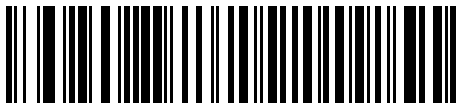

**Long Delay (40 msec)**

## USB Caps Lock Override

This option applies only to the HID Keyboard Emulation device. Enable this to preserve the case of the data regardless of the state of the caps lock key. This setting is always enabled for the Japanese, Windows (ASCII) keyboard type and can not be disabled.

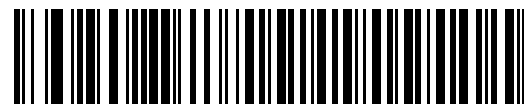

**Override Caps Lock Key  
(Enable)**



**\*Do Not Override Caps Lock Key  
(Disable)**

## USB Ignore Unknown Characters

Unknown characters are characters the host does not recognize. Select **Send Bar Codes With Unknown Characters** to send all bar code data except for unknown characters. The digital scanner issues no error beeps.

Select **Do Not Send Bar Codes With Unknown Characters** to prevent sending bar codes containing at least one unknown character to the host. The digital scanner issues an error beep.



**\*Send Bar Codes with Unknown Characters  
(Enable)**

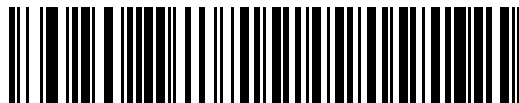

**Do Not Send Bar Codes with Unknown Characters  
(Disable)**

## Emulate Keypad

Enable this to send all characters as ASCII sequences over the numeric keypad. For example ASCII A transmits as "ALT make" 0 6 5 "ALT Break."



**\*Disable Keypad Emulation**

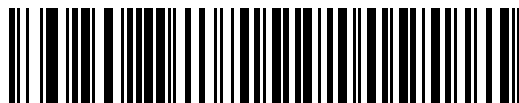

**Enable Keypad Emulation**

## USB Keyboard FN1 Substitution

This option applies only to the USB HID Keyboard Emulation device. Enable this to replace any FN1 characters in an EAN 128 bar code with a user-selected Key Category and value. See [FN1 Substitution Values on page 14-6](#) to set the Key Category and Key Value.

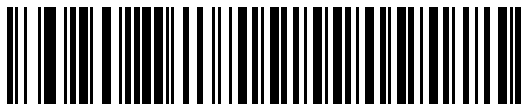

**Enable USB Keyboard FN 1 Substitution**

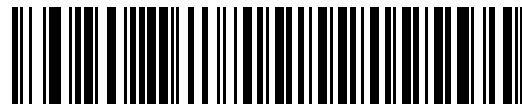

**\*Disable USB Keyboard FN 1 Substitution**

## Function Key Mapping

ASCII values under 32 normally transmit as control-key sequences (see [Table 8-2 on page 8-11](#)). Enable this parameter to send the keys shown in bold in the table in place of the standard key mapping. Table entries that do not have a bold entry remain the same regardless of this parameter.

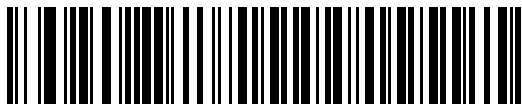

**\*Disable Function Key Mapping**



**Enable Function Key Mapping**

## Simulated Caps Lock

Enable this to invert upper and lower case characters on the scanned bar code as if the Caps Lock state is enabled on the keyboard. This inversion occurs regardless of the keyboard's Caps Lock state.



**\*Disable Simulated Caps Lock**

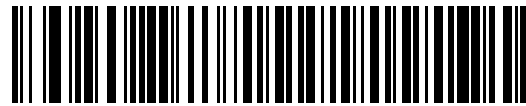

**Enable Simulated Caps Lock**

## Convert Case

Enable this to convert all bar code data to the selected case.

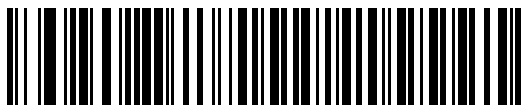

**\*No Case Conversion**

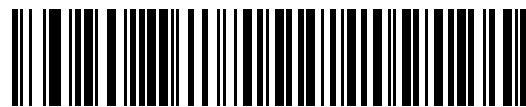

**Convert All to Upper Case**



**Convert All to Lower Case**



## ASCII Character Set

**Table 8-2** USB ASCII Character Set

ASCII Value	Full ASCII Code 39 Encode Character	Keystroke
1000	%U	CTRL 2
1001	\$A	CTRL A
1002	\$B	CTRL B
1003	\$C	CTRL C
1004	\$D	CTRL D
1005	\$E	CTRL E
1006	\$F	CTRL F
1007	\$G	CTRL G
1008	\$H	CTRL H/ <b>BACKSPACE</b> <sup>1</sup>
1009	\$I	CTRL I/ <b>HORIZONTAL TAB</b> <sup>1</sup>
1010	\$J	CTRL J
1011	\$K	CTRL K
1012	\$L	CTRL L
1013	\$M	CTRL M/ <b>ENTER</b> <sup>1</sup>
1014	\$N	CTRL N
1015	\$O	CTRL O
1016	\$P	CTRL P
1017	\$Q	CTRL Q
1018	\$R	CTRL R
1019	\$S	CTRL S
1020	\$T	CTRL T
1021	\$U	CTRL U
1022	\$V	CTRL V
1023	\$W	CTRL W
1024	\$X	CTRL X

<sup>1</sup>The keystroke in bold transmits only if you enabled *Function Key Mapping* on page 8-9. Otherwise, the unbolded keystroke transmits.

**Table 8-2** USB ASCII Character Set (Continued)

ASCII Value	Full ASCII Code 39 Encode Character	Keystroke
1025	\$Y	CTRL Y
1026	\$Z	CTRL Z
1027	%A	CTRL [/ <b>ESC</b> <sup>1</sup>
1028	%B	CTRL \
1029	%C	CTRL ]
1030	%D	CTRL 6
1031	%E	CTRL -
1032	Space	Space
1033	/A	!
1034	/B	“
1035	/C	#
1036	/D	\$
1037	/E	%
1038	/F	&
1039	/G	‘
1040	/H	(
1041	/I	)
1042	/J	*
1043	/K	+
1044	/L	,
1045	-	-
1046	.	.
1047	/O	/
1048	0	0
1049	1	1
1050	2	2
1051	3	3
1052	4	4

<sup>1</sup>The keystroke in bold transmits only if you enabled *Function Key Mapping* on page 8-9. Otherwise, the unbolded keystroke transmits.

**Table 8-2** USB ASCII Character Set (Continued)

ASCII Value	Full ASCII Code 39 Encode Character	Keystroke
1053	5	5
1054	6	6
1055	7	7
1056	8	8
1057	9	9
1058	/Z	:
1059	%F	;
1060	%G	<
1061	%H	=
1062	%I	>
1063	%J	?
1064	%V	@
1065	A	A
1066	B	B
1067	C	C
1068	D	D
1069	E	E
1070	F	F
1071	G	G
1072	H	H
1073	I	I
1074	J	J
1075	K	K
1076	L	L
1077	M	M
1078	N	N
1079	O	O
1080	P	P

<sup>1</sup>The keystroke in bold transmits only if you enabled *Function Key Mapping* on page 8-9. Otherwise, the unbolded keystroke transmits.

**Table 8-2** USB ASCII Character Set (Continued)

ASCII Value	Full ASCII Code 39 Encode Character	Keystroke
1081	Q	Q
1082	R	R
1083	S	S
1084	T	T
1085	U	U
1086	V	V
1087	W	W
1088	X	X
1089	Y	Y
1090	Z	Z
1091	%K	[
1092	%L	\
1093	%M	]
1094	%N	^
1095	%O	_
1096	%W	`
1097	+A	<b>a</b>
1098	+B	<b>b</b>
1099	+C	<b>c</b>
1100	+D	<b>d</b>
1101	+E	<b>e</b>
1102	+F	<b>f</b>
1103	+G	<b>g</b>
1104	+H	<b>h</b>
1105	+I	<b>i</b>
1106	+J	<b>j</b>
1107	+K	<b>k</b>
1108	+L	<b>l</b>

<sup>1</sup>The keystroke in bold transmits only if you enabled *Function Key Mapping* on page 8-9. Otherwise, the unbolded keystroke transmits.

**Table 8-2** USB ASCII Character Set (Continued)

ASCII Value	Full ASCII Code 39 Encode Character	Keystroke
1109	+M	m
1110	+N	n
1111	+O	o
1112	+P	p
1113	+Q	q
1114	+R	r
1115	+S	s
1116	+T	t
1117	+U	u
1118	+V	v
1119	+W	w
1120	+X	x
1121	+Y	y
1122	+Z	z
1123	%P	{
1124	%Q	
1125	%R	}
1126	%S	~

<sup>1</sup>The keystroke in bold transmits only if you enabled *Function Key Mapping* on page 8-9. Otherwise, the unbolded keystroke transmits.

**Table 8-3** USB ALT Key Character Set

ALT Keys	Keystroke
2064	ALT 2
2065	ALT A
2066	ALT B
2067	ALT C
2068	ALT D
2069	ALT E
2070	ALT F
2071	ALT G
2072	ALT H
2073	ALT I
2074	ALT J
2075	ALT K
2076	ALT L
2077	ALT M
2078	ALT N
2079	ALT O
2080	ALT P
2081	ALT Q
2082	ALT R
2083	ALT S
2084	ALT T
2085	ALT U
2086	ALT V
2087	ALT W
2088	ALT X
2089	ALT Y
2090	ALT Z

**Table 8-4** USB GUI Key Character Set

GUI Key	Keystroke
3000	Right Control Key
3048	GUI 0
3049	GUI 1
3050	GUI 2
3051	GUI 3
3052	GUI 4
3053	GUI 5
3054	GUI 6
3055	GUI 7
3056	GUI 8
3057	GUI 9
3065	GUI A
3066	GUI B
3067	GUI C
3068	GUI D
3069	GUI E
3070	GUI F
3071	GUI G
3072	GUI H
3073	GUI I
3074	GUI J
3075	GUI K
3076	GUI L
3077	GUI M
3078	GUI N
3079	GUI O
3080	GUI P

**Note:** GUI Shift Keys - The Apple™ iMac keyboard has an apple key on either side of the space bar. Windows-based systems have a GUI key to the left of the left ALT key, and to the right of the right ALT key.

**Table 8-4** USB GUI Key Character Set (Continued)

GUI Key	Keystroke
3081	GUI Q
3082	GUI R
3083	GUI S
3084	GUI T
3085	GUI U
3086	GUI V
3087	GUI W
3088	GUI X
3089	GUI Y
3090	GUI Z

**Note:** GUI Shift Keys - The Apple™ iMac keyboard has an apple key on either side of the space bar. Windows-based systems have a GUI key to the left of the left ALT key, and to the right of the right ALT key.



**Table 8-5** *USB F Key Character Set*

<b>F Keys</b>	<b>Keystroke</b>
5001	F1
5002	F2
5003	F3
5004	F4
5005	F5
5006	F6
5007	F7
5008	F8
5009	F9
5010	F10
5011	F11
5012	F12
5013	F13
5014	F14
5015	F15
5016	F16
5017	F17
5018	F18
5019	F19
5020	F20
5021	F21
5022	F22
5023	F23
5024	F24

**Table 8-6** *USB Numeric Keypad Character Set*

<b>Numeric Keypad</b>	<b>Keystroke</b>
6042	*
6043	+
6044	undefined
6045	-
6046	.
6047	/
6048	0
6049	1
6050	2
6051	3
6052	4
6053	5
6054	6
6055	7
6056	8
6057	9
6058	Enter
6059	Num Lock

**Table 8-7** *USB Extended Keypad Character Set*

<b>Extended Keypad</b>	<b>Keystroke</b>
7001	Break
7002	Delete
7003	PgUp
7004	End
7005	Pg Dn
7006	Pause
7007	Scroll Lock
7008	Backspace
7009	Tab
7010	Print Screen
7011	Insert
7012	Home
7013	Enter
7014	Escape
7015	Up Arrow
7016	Down Arrow
7017	Left Arrow
7018	Right Arrow



# Chapter 9 IBM 468X/469X Interface

---

## Introduction

This chapter provides instructions for programming the digital scanner to interface with an IBM 468X/469X host computer.

Throughout the programming bar code menus, asterisks (\*) indicate default values.

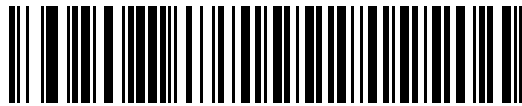

\* Indicates Default — **\*Disable Convert to Code 39** — Feature/Option

## Connecting to an IBM 468X/469X Host

Connect the digital scanner cradle directly to the host interface.

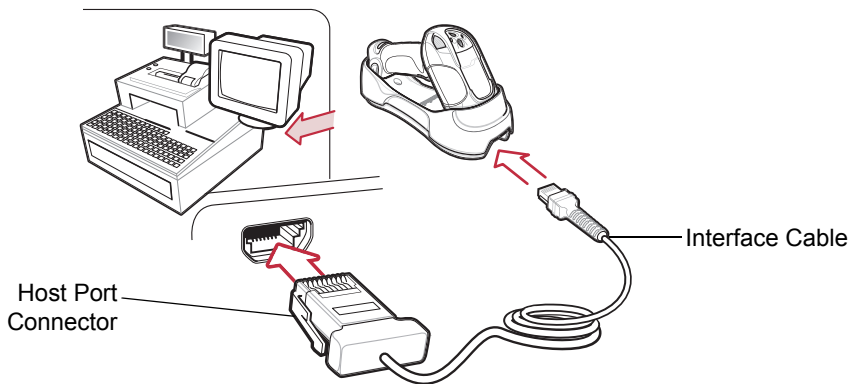

**Figure 9-1** IBM Direct Connection

- ✓ **NOTE** Interface cables vary depending on configuration. The connectors may be different from those illustrated in [Figure 9-1](#), but the steps to connect the digital scanner cradle are the same.

Disconnect the power supply before changing host cables or the digital scanner may not recognize the new host.

1. Connect the modular connector of the IBM 46XX interface cable to the cable interface port on the digital scanner cradle. See [Connecting the Cradle on page 1-4](#).
2. Connect the other end of the IBM 46XX interface cable to the appropriate port on the host computer (typically Port 9).
3. Ensure all connections are secure.
4. Pair the digital scanner to the cradle by scanning the bar code on the cradle.
5. Select the port address by scanning the appropriate bar code from [Port Address on page 9-4](#).
6. To modify other parameter options, scan the appropriate bar codes in this chapter.
7. Connect an external power supply if required.

- ✓ **NOTE** The only required configuration is the port address. The IBM system controls most other digital scanner parameters.

## IBM Default Parameters

*Table 9-1* lists the defaults for IBM host parameters. To change any option, scan the appropriate bar code(s) provided in the parameter descriptions section beginning on [page 9-4](#).

✓ **NOTE** See [Appendix A, Standard Default Parameters](#) for all user preference, host, symbology, and miscellaneous default parameters.

**Table 9-1** *IBM Host Default Table*

Parameter	Default	Page Number
<b>IBM 468X/469X Host Parameters</b>		
Port Address	None Selected	<a href="#">9-4</a>
Convert Unknown to Code 39	Disable	<a href="#">9-5</a>

---

## IBM 468X/469X Host Parameters

### Port Address

Use this parameter to set the IBM 468X/469X port.

✓ **NOTE** Scanning one of these bar codes enables the RS-485 interface on the digital scanner.

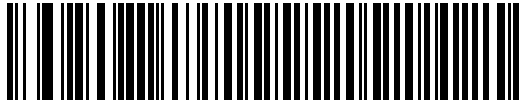

Hand-held Scanner Emulation (Port 9B)



Non-IBM Scanner Emulation (Port 5B)



Table-top Scanner Emulation (Port 17)



## Convert Unknown to Code 39

Scan one of the following bar codes to enable or disable converting unknown bar code type data to Code 39.



**Convert Unknown to Code 39 (Enable)**

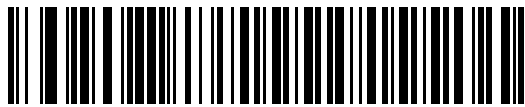

**\*Do Not Convert Unknown to Code 39 (Disable)**



# Chapter 10 Wand Emulation Interface

---

## Introduction

This chapter provides instructions for programming the digital scanner to interface with a wand emulation host. Use this mode whenever you need wand emulation communication. The digital scanner cradle connects either to an external wand decoder or to a decoder integrated in a portable terminal or Point-of-Sale (POS) terminal.

In this mode the digital scanner emulates the signal of a digital wand to make it “readable” by a wand decoder.

Throughout the programming bar code menus, asterisks (\*) indicate default values.



\* Indicates Default ——— \***Transmit Unknown** ——— Feature/Option  
**Characters**

## Connecting a Wand Emulation Interface

To perform wand emulation, connect the digital scanner cradle to a portable data terminal, or a controller that collects the wand data and interprets it for the host.

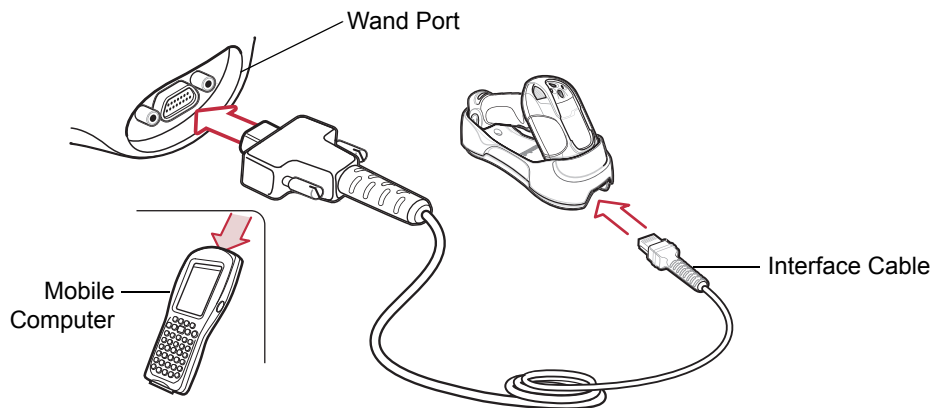

**Figure 10-1** Wand Emulation Connection

- ✓ **NOTE** Interface cables vary depending on configuration. The connectors may be different from those illustrated in [Figure 10-1](#), but the steps to connect the digital scanner cradle are the same.

Disconnect the power supply before changing host cables or the digital scanner may not recognize the new host.

1. Attach the modular connector of the wand emulation interface cable to the cable interface port on the digital scanner cradle. See [Connecting the Cradle on page 1-4](#).
2. Connect the other end of the wand emulation interface cable to the wand port on the mobile computer or controller.
3. Ensure all connections are secure.
4. Pair the digital scanner to the cradle by scanning the bar code on the cradle.
5. Select the wand emulation host type by scanning the appropriate bar code from [Wand Emulation Host Types on page 10-4](#).
6. To modify other parameter options, scan the appropriate bar codes in this chapter.
7. Connect an external power supply if required.



**CAUTION** Connect the cradle to a 5 volt decoder only. Connecting to a 12 volt decoder can cause damage and invalidate the warranty.

## Wand Emulation Default Parameters

*Table 10-1* lists the defaults for wand emulation host types. To change any option, scan the appropriate bar code(s) provided in this chapter.

✓ **NOTE** See *Appendix A, Standard Default Parameters* for all user preference, host, symbology, and miscellaneous default parameters.

**Table 10-1** *Wand Emulation Default Table*

Parameter	Default	Page Number
<b>Wand Emulation Host Parameters</b>		
Wand Emulation Host Types	Symbol OmniLink Interface Controller	<a href="#">10-4</a>
Leading Margin	80 msec	<a href="#">10-5</a>
Polarity	Bar High/Margin Low	<a href="#">10-6</a>
Ignore Unknown Characters	Enable	<a href="#">10-6</a>
Convert All to Code 39	Disable	<a href="#">10-7</a>
Convert Code 39 to Full ASCII	Disable	<a href="#">10-8</a>

---

## Wand Emulation Host Parameters

### Wand Emulation Host Types

Select the wand emulation host by scanning one of the bar codes below.

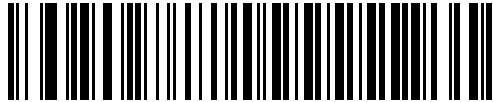

**Symbol OmniLink Interface Controller**

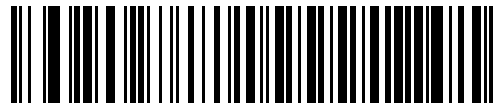

**Symbol PDT Terminal (MSI)**



**Symbol PTC Terminal (Telxon)**

### Leading Margin (Quiet Zone)

Scan a bar code below to select a leading margin duration. A leading margin is the time that precedes the first bar of the scan, in milliseconds. The minimum allowed value is 80 msec and the maximum is 250 msec. Use this parameter to accommodate older wand decoders that cannot handle short leading margins.

✓ **NOTE** 250 msec is the maximum value that this parameter can attain, however, 200 msec is sufficient.

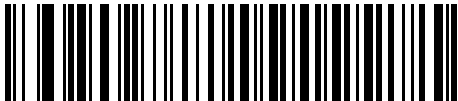

\*80 msec

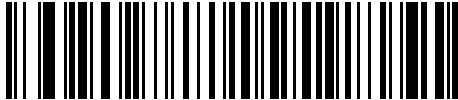

140 msec

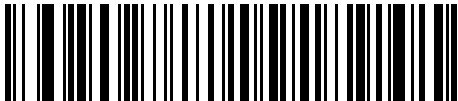

200 msec

## Polarity

Polarity determines how the digital scanner's wand emulation interface creates the Digitized Bar code Pattern (DBP). DBP is a digital signal that represents the scanned bar code. Different decoders expect the DBP in a certain format. The DBP either uses "highs" to represent bars and "lows" to represent spaces (margins), or "highs" to represent spaces (margins) and "lows" to represent bars.

Scan the appropriate bar code to select the polarity required by the decoder.

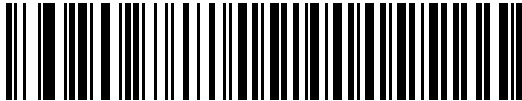

**\*Bar High/Margin Low**



**Bar Low/Margin High**

## Ignore Unknown Characters

Unknown characters are characters the host does not recognize. Select **Send Bar Codes With Unknown Characters** to send all bar code data except for unknown characters. The digital scanner issues no error beeps.

Select **Do Not Send Bar Codes With Unknown Characters** to prevent sending bar codes containing at least one unknown character to the host. The digital scanner issues an error beep.



**\*Send Bar Codes With Unknown Characters  
(Enable)**



**Do Not Send Bar Codes With Unknown Characters  
(Disable)**



## Convert All to Code 39

By default, the wand emulation interface sends data to the attached host in the decoded symbology. This can present a problem for older systems that do not recognize some newer symbologies (for example, GS1 DataBar).

Enable this parameter to ignore the decoded symbology, and transmit the data as a Code 39 bar code. Lowercase characters in the original data stream transmit as uppercase characters. This also allows ADF formatting.

If you enabled **Ignore Unknown Characters**, the digital scanner replaces characters that do not have a corresponding character in the Code 39 symbology with a space.

If you disabled **Ignore Unknown Characters**, and the digital scanner encounters characters that do not have a corresponding Code 39 character, it emits an error beep and does not transmit data.

ADF Note: By default, the wand emulation interface does not allow scanned data to use ADF rules. Enabling this parameter allows the scanned data to use ADF rules. See [Chapter 15, Advanced Data Formatting](#).

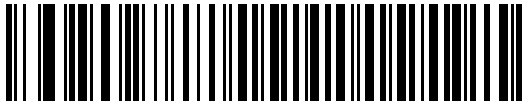

**Convert All to Code 39 for Wand Host  
(Enable)**



**\*Do Not Convert All to Code 39 for Wand Host  
(Disable)**

## Convert Code 39 to Full ASCII

By default, this parameter replaces any characters that do not have a corresponding character in the Code 39 symbology with a space. Enable this parameter to encode the data sent to the wand interface in Code 39 Full ASCII. This setting requires that the host be able to interpret Code 39 Full ASCII data.

This setting applies only if you enabled **Convert All to Code 39** for wand hosts.

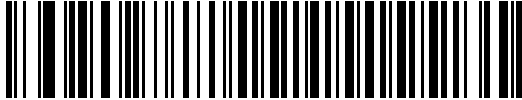

**\*Do Not Convert Code 39 to Full ASCII  
(Disable)**

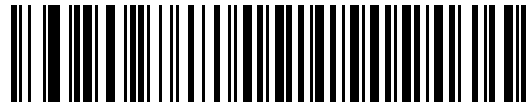

**Convert Code 39 to Full ASCII  
(Enable)**

# Chapter 11 Scanner Emulation Interface

---

## Introduction

This chapter provides instructions for programming the digital scanner to interface with a scanner emulation host. With scanner emulation, the cradle connects either to an external decoder or to a decoder integrated in a portable terminal or Point-of-Sale (POS) terminal.

Throughout the programming bar code menus, asterisks (\*) indicate default values.



\* Indicates Default — **\*Parameter Process** — Feature/Option  
and Pass-Through

## Connecting Using Scanner Emulation

To perform scanner emulation, connect the digital scanner cradle to a mobile computer, or a controller that collects the data and interprets it for the host.

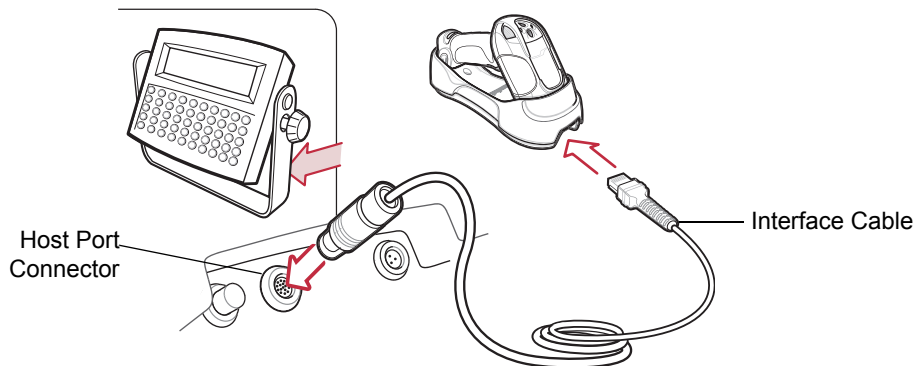

**Figure 11-1** Scanner Emulation Connection

- ✓ **NOTE** Interface cables vary depending on configuration. The connectors may be different from those illustrated in [Figure 11-1](#), but the steps to connect the digital scanner cradle are the same.

Disconnect the power supply before changing host cables or the digital scanner may not recognize the new host.

1. Attach the modular connector of the scanner emulation interface cable to the cable interface port on the digital scanner cradle. See [Connecting the Cradle on page 1-4](#).
2. Connect the other end of the scanner emulation interface cable to the scanner port on the mobile computer or controller.
3. Ensure all connections are secure.
4. Pair the digital scanner to the cradle by scanning the bar code on the cradle.
5. Scan [Scanner Emulation Host on page 11-4](#) to enable the scanner emulation interface.
6. To modify parameter options, scan the appropriate bar codes in this chapter.
7. Connect an external power supply if required.



**CAUTION** Connect the cradle to a 5 volt decoder only. Connecting to a 12 volt decoder can cause damage and invalidate the warranty.

## Scanner Emulation Default Parameters

[Table 11-1](#) lists the defaults for the scanner emulation host. To change an option, scan the appropriate bar code(s) provided in this chapter.

✓ **NOTE** See [Appendix A, Standard Default Parameters](#) for all user preference, host, symbology, and miscellaneous default parameters.

**Table 11-1** *Scanner Emulation Default Table*

Parameter	Default	Page Number
<b>Scanner Emulation Host Parameters</b>		
Beep Style	Beep on Successful Transmit	<a href="#">11-4</a>
Parameter Pass-Through	Parameter Process and Pass Through	<a href="#">11-5</a>
Convert Newer Code Types	Convert Newer Code Types	<a href="#">11-6</a>
Module Width	20 $\mu$ s Module Width	<a href="#">11-7</a>
Convert All Bar Codes to Code 39	Disable	<a href="#">11-7</a>
Code 39 Full ASCII Conversion	Disable	<a href="#">11-8</a>
Transmission Timeout	3 seconds	<a href="#">11-9</a>
Ignore Unknown Characters	Send Bar Codes with Unknown Characters	<a href="#">11-10</a>
Leading Margin	2 ms	<a href="#">11-11</a>
Check for Decode LED	Check for Decode LED	<a href="#">11-12</a>

---

## Scanner Emulation Host Parameters

### Scanner Emulation Host

Scan the following bar code to enable the scanner emulation host.



Scanner Emulation Host

### Beep Style

The scanner emulation host supports three different beep styles.

- **Beep On Successful Transmit** (default): The digital scanner beeps when the attached decoder issues the decode signal to the digital scanner. This way, the digital scanner and the decoder beep at the same time.
- **Beep at Decode Time:** The digital scanner beeps on its decode. This results in a double beep sequence from most decoders, since the digital scanner beeps, and the decoder beeps (at a different frequency) when it successfully decodes the output.
- **Do Not Beep:** The digital scanner does not beep; the attached decoder issues the decode beep.

In all cases, if an error occurs, the digital scanner issues error beeps.



\*Beep On Successful Transmit



Beep at Decode Time



Do Not Beep

## Parameter Pass-Through

The scanner emulation host can process parameter bar code messages and send them to the attached decoder. In this way, customers using Symbol-compliant decoders can control the behavior of the system by scanning the necessary parameters only once.



**NOTE** For example, to enable Discrete 2 of 5, scan the **Enable Discrete 2 of 5** parameter bar code with the digital scanner. The digital scanner and the attached decoder both process the parameter.



**\*Parameter Process and Pass-Through**



**Parameter Process Only**

## Convert Newer Code Types

The digital scanner supports a variety of code types that attached decoder systems typically cannot decode. To allow compatibility in these environments, the digital scanner converts these code types to more common symbologies, as per the following table. Symbologies not listed on this chart transmit normally.

Scan this code type:	Transmitted as:
Code 11	Code 39
GS1 DataBar (14, Limited, and Expanded), Coupon Code, PDF, MicroPDF, MaxiCode, Data Matrix, QR Code, Postal Codes, Composite Codes	Code 128

When decoding these code types with this parameter disabled, the digital scanner issues convert error beeps and transmits no data.



**\*Convert Newer Code Types**



**Reject Newer Code Types**



## Module Width

The standard module width is 20  $\mu$ s. For an extremely slow decoder system, use this parameter to extend this module width to 50  $\mu$ s.



**\*20  $\mu$ s Module Width**



**50  $\mu$ s Module Width**

## Convert All Bar Codes to Code 39

Scan the appropriate bar code to enable or disable converting all bar code data to Code 39.



**\*Do Not Convert All To Code 39  
(Disable)**



**Convert All To Code 39  
(Enable)**

## Code 39 Full ASCII Conversion

By default, this parameter replaces characters that do not have a corresponding character in the Code 39 symbology set with a space. Enable this parameter to encode the data sent to the scanner emulation host in Code 39 Full ASCII. This setting requires that the host be able to interpret Code 39 Full ASCII data.

This setting applies only if you enabled **Convert All to Code 39**.



**\*Do Not Convert Code 39 To Full ASCII  
(Disable)**



**Convert Code 39 To Full ASCII  
(Enable)**

## Transmission Timeout

The scanner emulation host transmits bar code data to the attached decoder and waits for the decoder to assert the decode signal, indicating successful transmission. If, after a specified amount of time, the decode signal is not asserted (indicating that the attached decoder did not receive the bar code data), the digital scanner issues transmit error beeps.

Scan the appropriate bar code to select the desired transmission timeout.



**\*3 Second Transmission Timeout**



**4 Second Transmission Timeout**



**5 Second Transmission Timeout**



**10 Second Transmission Timeout**



**30 Second Transmission Timeout**

## Ignore Unknown Characters

Unknown characters are characters that the host does not recognize. Select **Send Bar Codes With Unknown Characters** to send all bar code data except for unknown characters. The digital scanner issues no error beeps.

Select **Do Not Send Bar Codes With Unknown Characters** to prevent sending bar codes containing at least one unknown character to the host. The digital scanner issues an error beep.



**\*Send Bar Codes with Unknown Characters  
(Enable)**



**Do Not Send Bar Codes with Unknown Characters  
(Disable)**

## Leading Margin

Scan one of the following bar codes to select a leading margin duration.



**1 ms Leading Margin**



**\*2 ms Leading Margin**



**3 ms Leading Margin**



**5 ms Leading Margin**



**10 ms Leading Margin**

## Check for Decode LED

The attached decoder typically asserts the decode line to signal to the scanner emulation host that it successfully decoded the transmitted bar code. Some decoders, however, do not assert the decode signal upon a decode. In this case, the digital scanner emits transmit error beeps to indicate that the bar code did not successfully transmit. Scan the **Ignore Decode LED** bar code to disable the transmit error beeps.



**\*Check For Decode LED**



**Ignore Decode LED**

# Chapter 12 123Scan

---

## Introduction

123Scan is a Windows®-based utility that programs the digital scanner with all parameters including Advanced Data Formatting (ADF) rules. An ADF rule modifies bar code data before it transmits to the host, ensuring compatibility between bar code data and the host application without having to modify the host software. You can program digital scanners via PC download or by scanning a sheet of bar codes generated by 123Scan. Save digital scanner programming in a file for electronic distribution. 123Scan includes a help file.

---

## Setting Up 123Scan

To communicate with the 123Scan program:

1. Load 123Scan, included in the documentation CD-ROM, onto a host computer running Windows 98, Windows 2000, or Windows XP.
2. Connect the digital scanner to the host computer using an RS-232 cable. See [Connecting an RS-232 Interface on page 7-2](#).
3. Scan the following bar code to enable the 123Scan interface on the digital scanner. Refer to the 123Scan instructions for programming the digital scanner.



**123Scan Configuration**





# Chapter 13 Symbologies

---

## Introduction

This chapter describes symbology features and provides programming bar codes for selecting these features for the digital scanner. Before programming, follow the instructions in [Chapter 1, Getting Started](#).

The digital scanner ships with the settings shown in the [Symbology Default Table on page 13-2](#) (also see [Appendix A, Standard Default Parameters](#) for all host and miscellaneous digital scanner defaults). If the default values suit requirements, programming is not necessary. Set feature values by scanning single bar codes or short bar code sequences. To return all features to default values, scan [Set Default Parameter on page 4-3](#).

If not using a Synapse or USB cable, select the host type (see the specific host chapter) after the digital scanner emits power-up beeps.

---

## Scanning Sequence Examples

In most cases, scan only one bar code to set a parameter value. For example, to transmit bar code data without the UPC-A check digit, scan the [Do Not Transmit UPC-A Check Digit](#) bar code under [Transmit UPC-A/UPC-E/UPC-E1 Check Digit on page 13-14](#). The digital scanner issues a fast warble beep and the LED turns green, indicating a successful parameter entry.

Other parameters, such as **Set Length(s) for D 2 of 5** require scanning several bar codes in sequence. See the parameter description for this procedure.

---

## Errors While Scanning

Unless otherwise specified, if you make an error during a scanning sequence, re-scan the correct parameter.

## Symbology Default Parameters

[Table 13-1](#) lists the defaults for all symbologies parameters. To change any option, scan the appropriate bar code(s) provided in this chapter.

✓ **NOTE** See [Appendix A, Standard Default Parameters](#) for all user preference, host, symbology, and miscellaneous default parameters.

**Table 13-1** Symbology Default Table

Parameter	Default	Page Number
<b>UPC/EAN</b>		
UPC-A	Enable	<a href="#">13-7</a>
UPC-E	Enable	<a href="#">13-7</a>
UPC-E1	Disable	<a href="#">13-8</a>
EAN-13	Enable	<a href="#">13-8</a>
EAN-8	Enable	<a href="#">13-9</a>
Bookland EAN	Disable	<a href="#">13-9</a>
Decode UPC/EAN Supplementals (2 and 5 digits)	Ignore Supplementals	<a href="#">13-10</a>
User-Programmable Supplementals		<a href="#">13-13</a>
UPC/EAN Supplemental Redundancy	10	<a href="#">13-13</a>
Transmit UPC-A Check Digit	Enable	<a href="#">13-14</a>
Transmit UPC-E Check Digit	Enable	<a href="#">13-14</a>
Transmit UPC-E1 Check Digit	Enable	<a href="#">13-14</a>
UPC-A Preamble	System Character	<a href="#">13-16</a>
UPC-E Preamble	System Character	<a href="#">13-17</a>
UPC-E1 Preamble	System Character	<a href="#">13-18</a>
Convert UPC-E to A	Disable	<a href="#">13-19</a>
Convert UPC-E1 to A	Disable	<a href="#">13-19</a>
EAN-8 Extend	Disable	<a href="#">13-20</a>
Bookland ISBN Format	ISBN-10	<a href="#">13-21</a>
UCC Coupon Extended Code	Disable	<a href="#">13-22</a>
ISSN EAN	Disable	<a href="#">13-22</a>

**Table 13-1** Symbology Default Table (Continued)

Parameter	Default	Page Number
<b>Code 128</b>		
Code 128	Enable	13-23
Set Length(s) for Code 128	Any Length	13-23
GS1-128 (formerly UCC/EAN-128)	Enable	13-25
ISBT 128	Enable	13-25
ISBT Concatenation	Disable	13-26
Check ISBT Table	Enable	13-27
ISBT Concatenation Redundancy	10	13-27
<b>Code 39</b>		
Code 39	Enable	13-28
Trioptic Code 39	Disable	13-28
Convert Code 39 to Code 32	Disable	13-29
Code 32 Prefix	Disable	13-29
Set Length(s) for Code 39	2 to 55	13-30
Code 39 Check Digit Verification	Disable	13-40
Transmit Code 39 Check Digit	Disable	13-32
Code 39 Full ASCII Conversion	Disable	13-33
Buffer Code 39	Disable	13-34
<b>Code 93</b>		
Code 93	Disable	13-36
Set Lengths for Code 93	4 to 55	13-36
<b>Code 11</b>		
Code 11	Disable	13-38
Set Lengths for Code 11	4 to 55	13-38
Code 11 Check Digit Verification	Disable	13-40
Transmit Code 11 Check Digits	Disable	13-41
<b>Interleaved 2 of 5 (I 2 of 5)</b>		
Interleaved 2 of 5 (I 2 of 5)	Enable	13-42
Set Lengths for Interleaved 2 of 5	14	13-42
I 2 of 5 Check Digit Verification	Disable	13-44

**Table 13-1** Symbology Default Table (Continued)

Parameter	Default	Page Number
Transmit I 2 of 5 Check Digit	Disable	<a href="#">13-44</a>
Convert I 2 of 5 to EAN-13	Disable	<a href="#">13-45</a>
<b>Discrete 2 of 5 (D 2 of 5)</b>		
Discrete 2 of 5	Disable	<a href="#">13-46</a>
Set Lengths for D 2 of 5	12	<a href="#">13-46</a>
<b>Codabar (NW - 7)</b>		
Codabar	Disable	<a href="#">13-48</a>
Set Lengths for Codabar	5 to 55	<a href="#">13-48</a>
CLSI Editing	Disable	<a href="#">13-50</a>
NOTIS Editing	Disable	<a href="#">13-50</a>
<b>MSI</b>		
MSI	Disable	<a href="#">13-51</a>
Set Lengths for MSI	4 to 55	<a href="#">13-51</a>
MSI Check Digits	One	<a href="#">13-53</a>
Transmit MSI Check Digit(s)	Disable	<a href="#">13-53</a>
MSI Check Digit Algorithm	Mod 10/Mod 10	<a href="#">13-54</a>
<b>Chinese 2 of 5</b>		
Chinese 2 of 5	Disable	<a href="#">13-54</a>
<b>Matrix 2 of 5</b>		
Matrix 2 of 5	Disable	<a href="#">13-55</a>
Matrix 2 of 5 Lengths	1 Length - 14	<a href="#">13-56</a>
Matrix 2 of 5 Redundancy	Disable	<a href="#">13-57</a>
Matrix 2 of 5 Check Digit	Disable	<a href="#">13-57</a>
Transmit Matrix 2 of 5 Check Digit	Disable	<a href="#">13-58</a>
<b>Inverse 1D</b>	Regular	<a href="#">13-58</a>
<b>Postal Codes</b>		
US Postnet	Enable	<a href="#">13-59</a>
US Planet	Enable	<a href="#">13-59</a>
Transmit US Postal Check Digit	Enable	<a href="#">13-60</a>
UK Postal	Enable	<a href="#">13-60</a>

**Table 13-1** Symbology Default Table (Continued)

Parameter	Default	Page Number
Transmit UK Postal Check Digit	Enable	13-61
Japan Postal	Enable	13-61
Australian Postal	Enable	13-62
Netherlands KIX Code	Enable	13-62
USPS 4CB/One Code/Intelligent Mail	Disable	13-63
UPU FICS Postal	Disable	13-63
<b>GS1 DataBar</b>		
GS1 DataBar-14	Enable	13-64
GS1 DataBar Limited	Enable	13-64
GS1 DataBar Expanded	Enable	13-65
Convert GS1 DataBar to UPC/EAN	Disable	13-65
<b>Composite</b>		
Composite CC-C	Disable	13-66
Composite CC-A/B	Disable	13-66
Composite TLC-39	Disable	13-67
UPC Composite Mode	Always Linked	13-67
GS1-128 Emulation Mode for UCC/EAN Composite Codes	Disable	13-68
<b>2D Symbologies</b>		
PDF417	Enable	13-69
MicroPDF417	Disable	13-69
Code 128 Emulation	Disable	13-70
Data Matrix	Enable	13-71
Data Matrix Inverse	Regular	13-71
Maxicode	Enable	13-72
QR Code	Enable	13-73
QR Inverse	Regular	13-73
MicroQR	Enable	13-74
Aztec	Enable	13-75
Aztec Inverse	Enable	13-75

**Table 13-1** Symbology Default Table (Continued)

Parameter	Default	Page Number
<b>Symbology - Specific Security Levels</b>		
Redundancy Level	1	<a href="#">13-76</a>
Security Levels	0	<a href="#">13-78</a>
Intercharacter Gap Size	Normal	<a href="#">13-80</a>
<b>Macro PDF</b>		
Flush Macro PDF Buffer		<a href="#">13-81</a>
Abort Macro PDF Entry		<a href="#">13-81</a>

---

## UPC/EAN

### Enable/Disable UPC-A

To enable or disable UPC-A, scan the appropriate bar code below.

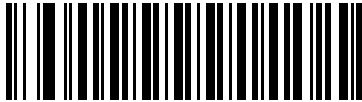

**\*Enable UPC-A**

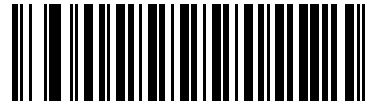

**Disable UPC-A**

### Enable/Disable UPC-E

To enable or disable UPC-E, scan the appropriate bar code below.

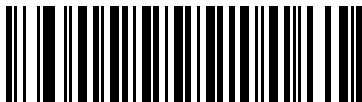

**\*Enable UPC-E**

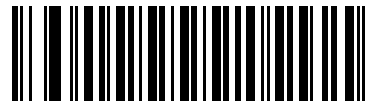

**Disable UPC-E**

## Enable/Disable UPC-E1

To enable or disable UPC-E1, scan the appropriate bar code below.

✓ **NOTE** UPC-E1 is not a UCC (Uniform Code Council) approved symbology.

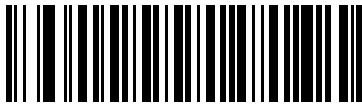

**Enable UPC-E1**

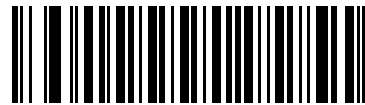

**\*Disable UPC-E1**

## Enable/Disable EAN-13

To enable or disable EAN-13, scan the appropriate bar code below.

✓ **NOTE** JAN is a subset of EAN, therefore parameters controlling EAN also affect JAN.

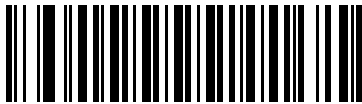

**\*Enable EAN-13**



**Disable EAN-13**



## Enable/Disable EAN-8

To enable or disable EAN-8, scan the appropriate bar code below.

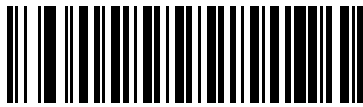

\*Enable EAN-8

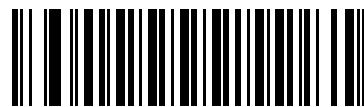

Disable EAN-8

## Enable/Disable Bookland EAN

To enable or disable Bookland EAN, scan the appropriate bar code below.

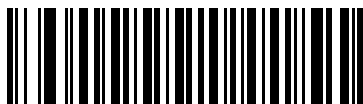

Enable Bookland EAN



\*Disable Bookland EAN



**NOTE** If you enable Bookland EAN, select a [Bookland ISBN Format on page 13-21](#). Also select either Decode UPC/EAN Supplementals, Autodiscriminate UPC/EAN Supplementals, or Enable 978/979 Supplemental Mode in [Decode UPC/EAN Supplementals on page 13-10](#).

## Decode UPC/EAN Supplementals

Supplementals are bar codes appended according to specific format conventions (e.g., UPC A+2, UPC E+2, EAN 13+2). The following options are available:

- If you select **Ignore UPC/EAN with Supplementals**, and the scanner is presented with a UPC/EAN plus supplemental symbol, the scanner decodes UPC/EAN and ignores the supplemental characters.
- If you select **Decode UPC/EAN with Supplementals**, the scanner only decodes UPC/EAN symbols with supplemental characters, and ignores symbols without supplementals.
- If you select **Autodiscriminate UPC/EAN Supplementals**, the scanner decodes UPC/EAN symbols with supplemental characters immediately. If the symbol does not have a supplemental, the scanner must decode the bar code the number of times set via [UPC/EAN Supplemental Redundancy on page 13-13](#) before transmitting its data to confirm that there is no supplemental.
- If you select one of the following **Supplemental Mode** options, the scanner immediately transmits EAN-13 bar codes starting with that prefix that have supplemental characters. If the symbol does not have a supplemental, the scanner must decode the bar code the number of times set via [UPC/EAN Supplemental Redundancy on page 13-13](#) before transmitting its data to confirm that there is no supplemental. The scanner transmits UPC/EAN bar codes that do not have that prefix immediately.
  - **Enable 378/379 Supplemental Mode**
  - **Enable 978/979 Supplemental Mode**



**NOTE** If you select 978/979 Supplemental Mode and are scanning Bookland EAN bar codes, see [Enable/Disable Bookland EAN on page 13-9](#) to enable Bookland EAN, and select a format using [Bookland ISBN Format on page 13-21](#).

- **Enable 977 Supplemental Mode**
- **Enable 414/419/434/439 Supplemental Mode**
- **Enable 491 Supplemental Mode**
- **Enable Smart Supplemental Mode** - applies to EAN-13 bar codes starting with any prefix listed previously.
- **Supplemental User-Programmable Type 1** - applies to EAN-13 bar codes starting with a 3-digit user-defined prefix. [User-Programmable Supplementals on page 13-13](#).
- **Supplemental User-Programmable Type 1 and 2** - applies to EAN-13 bar codes starting with either of two 3-digit user-defined prefixes. Set the 3-digit prefixes using [User-Programmable Supplementals on page 13-13](#).
- **Smart Supplemental Plus User-Programmable 1** - applies to EAN-13 bar codes starting with any prefix listed previously or the user-defined prefix set using [User-Programmable Supplementals on page 13-13](#).
- **Smart Supplemental Plus User-Programmable 1 and 2** - applies to EAN-13 bar codes starting with any prefix listed previously or one of the two user-defined prefixes set using [User-Programmable Supplementals on page 13-13](#).



**NOTE** To minimize the risk of invalid data transmission, select either to decode or ignore supplemental characters.

## Decode UPC/EAN/JAN Supplementals (continued)

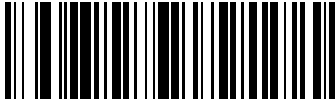

Decode UPC/EAN/JAN Only With Supplementals



\*Ignore Supplementals

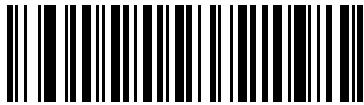

Autodiscriminate UPC/EAN/JAN Supplementals



Enable 378/379 Supplemental Mode



Enable 978/979 Supplemental Mode



Enable 977 Supplemental Mode

### Decode UPC/EAN/JAN Supplementals (continued)



Enable 414/419/434/439 Supplemental Mode



Enable 491 Supplemental Mode



Enable Smart Supplemental Mode



Supplemental User-Programmable Type 1



Supplemental User-Programmable Type 1 and 2



Smart Supplemental Plus User-Programmable 1



Smart Supplemental Plus User-Programmable 1 and 2

## User-Programmable Supplementals

If you selected a Supplemental User-Programmable option from [Decode UPC/EAN Supplementals on page 13-10](#), select **User-Programmable Supplemental 1** to set the 3-digit prefix. Then select the 3 digits using the numeric bar codes beginning on [page D-1](#). Select **User-Programmable Supplemental 2** to set a second 3-digit prefix. Then select the 3 digits using the numeric bar codes beginning on [page D-1](#).



User-Programmable Supplemental 1



User-Programmable Supplemental 2

## UPC/EAN Supplemental Redundancy

If you selected **Autodiscriminate UPC/EAN Supplementals**, use this option to adjust the number of times to decode a symbol without supplementals before transmission. The range is from two to 30 times. 14 or above is recommended when decoding a mix of UPC/EAN symbols with and without supplementals. The default is 10.

To set a decode redundancy value, scan the following bar code. Next, scan two numeric bar codes from [Appendix D, Numeric Bar Codes](#). Use a leading zero for single digit numbers. In case of an error, or to change the selection, scan **Cancel** on [page D-3](#).

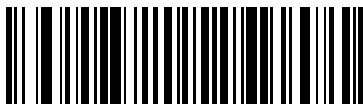

UPC/EAN Supplemental Redundancy

## Transmit UPC-A/UPC-E/UPC-E1 Check Digit

The check digit is the last character of the symbol used to verify the integrity of the data. Scan the appropriate bar code to transmit the bar code data with or without the UPC-A, UPC-E, or UPC-E1 check digit.

### UPC-A Check Digit

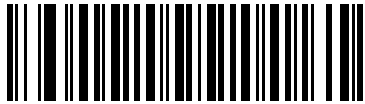

**\*Transmit UPC-A Check Digit**

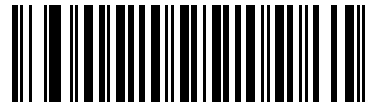

**Do Not Transmit UPC-A Check Digit**

### UPC-E Check Digit

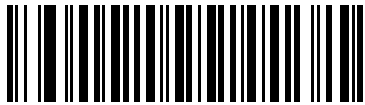

**\*Transmit UPC-E Check Digit**

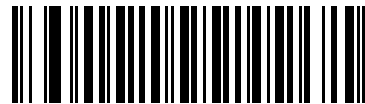

**Do Not Transmit UPC-E Check Digit**

**UPC-E1 Check Digit**

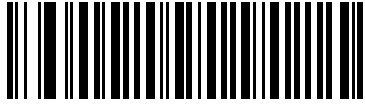

**\*Transmit UPC-E1 Check Digit**

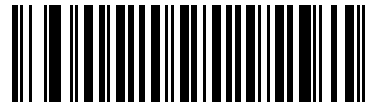

**/ Do Not Transmit UPC-E1 Check Digit**

## UPC-A Preamble

Preamble characters are part of the UPC symbol consisting of Country Code and System Character. There are three options for transmitting a UPC-A preamble to the host device:

- Transmit System Character only.
- Transmit System Character and Country Code ("0" for USA).
- Transmit no preamble.

Select the appropriate option to match the host system.



**No Preamble**  
**(<DATA>)**



**\*System Character**  
**(<SYSTEM CHARACTER> <DATA>)**

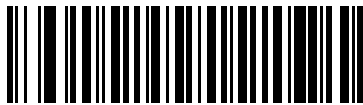

**System Character & Country Code**  
**(< COUNTRY CODE> <SYSTEM CHARACTER>**  
**<DATA>)**



## UPC-E Preamble

Preamble characters are part of the UPC symbol consisting of Country Code and System Character. There are three options for transmitting a UPC-E preamble to the host device:

- Transmit System Character only.
- Transmit System Character and Country Code ("0" for USA).
- Transmit no preamble.

Select the appropriate option to match the host system.

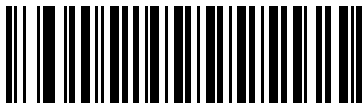

**No Preamble**  
(<DATA>)

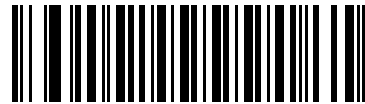

**\*System Character**  
(<SYSTEM CHARACTER> <DATA>)

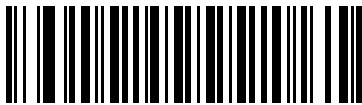

**System Character & Country Code**  
(< COUNTRY CODE> <SYSTEM CHARACTER>  
<DATA>)

## UPC-E1 Preamble

Preamble characters are part of the UPC symbol consisting of Country Code and System Character. There are three options for transmitting a UPC-E1 preamble to the host device:

- Transmit System Character only.
- Transmit System Character and Country Code ("0" for USA).
- Transmit no preamble.

Select the appropriate option to match the host system.



**No Preamble**  
(<DATA>)



**\*System Character**  
(<SYSTEM CHARACTER> <DATA>)

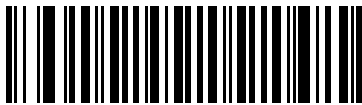

**System Character & Country Code**  
(< COUNTRY CODE> <SYSTEM CHARACTER>  
<DATA>)

## Convert UPC-E to UPC-A

Enable this to convert UPC-E (zero suppressed) decoded data to UPC-A format before transmission. After conversion, the data follows UPC-A format and is affected by UPC-A programming selections (e.g., Preamble, Check Digit).

Disable this to transmit UPC-E decoded data as UPC-E data, without conversion.

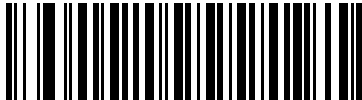

**Convert UPC-E to UPC-A  
(Enable)**



**\*Do Not Convert UPC-E to UPC-A  
(Disable)**

## Convert UPC-E1 to UPC-A

Enable this to convert UPC-E1 decoded data to UPC-A format before transmission. After conversion, the data follows UPC-A format and is affected by UPC-A programming selections (e.g., Preamble, Check Digit).

Disable this to transmit UPC-E1 decoded data as UPC-E1 data, without conversion.

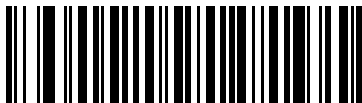

**Convert UPC-E1 to UPC-A  
(Enable)**



**\*Do Not Convert UPC-E1 to UPC-A  
(Disable)**

## **EAN-8 Extend**

Enable this parameter to add five leading zeros to decoded EAN-8 symbols to make them compatible in format to EAN-13 symbols.

Disable this to transmit EAN-8 symbols as is.

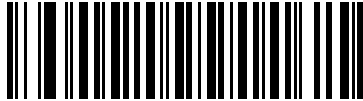

**Enable EAN-8 Zero Extend**

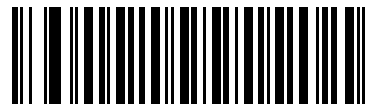

**\*Disable EAN-8 Zero Extend**

## Bookland ISBN Format

If you enabled Bookland EAN using [Enable/Disable Bookland EAN on page 13-9](#), select one of the following formats for Bookland data:

- **Bookland ISBN-10** - The scanner reports Bookland data starting with 978 in traditional 10-digit format with the special Bookland check digit for backward-compatibility. Data starting with 979 is not considered Bookland in this mode.
- **Bookland ISBN-13** - The scanner reports Bookland data (starting with either 978 or 979) as EAN-13 in 13-digit format to meet the 2007 ISBN-13 protocol.



\*Bookland ISBN-10



Bookland ISBN-13



**NOTE** For Bookland EAN to function properly, first enable Bookland EAN using [Enable/Disable Bookland EAN on page 13-9](#), then select either Decode UPC/EAN Supplementals, Autodiscriminate UPC/EAN Supplementals, or Enable 978/979 Supplemental Mode in [Decode UPC/EAN Supplementals on page 13-10](#).

## UCC Coupon Extended Code

Enable this parameter to decode UPC-A bar codes starting with digit '5', EAN-13 bar codes starting with digit '99', and UPC-A/GS1-128 coupon codes. UPC-A, EAN-13, and GS1-128 must be enabled to scan all types of coupon codes.

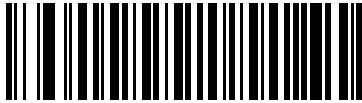

Enable UCC Coupon Extended Code

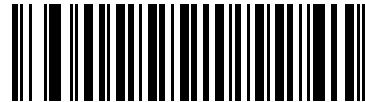

\*Disable UCC Coupon Extended Code



**NOTE** Use [UPC/EAN Supplemental Redundancy on page 13-13](#) to control autodiscrimination of the GS1-128 (right half) of a coupon code

## ISSN EAN

To enable or disable ISSN EAN, scan the appropriate bar code below.



Enable ISSN EAN



\*Disable ISSN EAN

---

## Code 128

### Enable/Disable Code 128

To enable or disable Code 128, scan the appropriate bar code below.



\*Enable Code 128

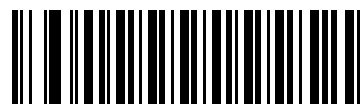

Disable Code 128

### Set Lengths for Code 128

The length of a code refers to the number of characters (i.e., human readable characters), including check digit(s) the code contains. Set lengths for Code 128 to any length, one or two discrete lengths, or lengths within a specific range.

✓ **NOTE** When setting lengths for different bar code types, enter a leading zero for single digit numbers.

- **One Discrete Length** - Select this option to decode only Code 128 symbols containing a selected length. Select the length using the numeric bar codes in [Appendix D, Numeric Bar Codes](#). For example, to decode only Code 128 symbols with 14 characters, scan **Code 128 - One Discrete Length**, then scan **1** followed by **4**. To correct an error or change the selection, scan [Cancel on page D-3](#).
- **Two Discrete Lengths** - Select this option to decode only Code 128 symbols containing either of two selected lengths. Select lengths using the numeric bar codes in [Appendix D, Numeric Bar Codes](#). For example, to decode only Code 128 symbols containing either 2 or 14 characters, select **Code 128 - Two Discrete Lengths**, then scan **0, 2, 1**, and then **4**. To correct an error or change the selection, scan [Cancel on page D-3](#).
- **Length Within Range** - Select this option to decode a Code 128 symbol with a specific length range. Select lengths using numeric bar codes in [Appendix D, Numeric Bar Codes](#). For example, to decode Code 128 symbols containing between 4 and 12 characters, first scan **Code 128 - Length Within Range**. Then scan **0, 4, 1**, and **2** (enter a leading zero for single digit numbers). To correct an error or change the selection, scan [Cancel on page D-3](#).
- **Any Length** - Select this option to decode Code 128 symbols containing any number of characters within the digital scanner's capability.

### Set Lengths for Code 128 (continued)

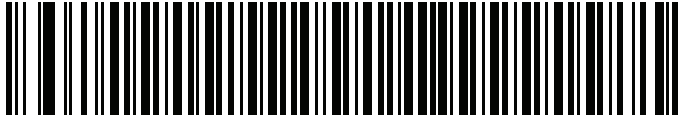

Code 128 - One Discrete Length

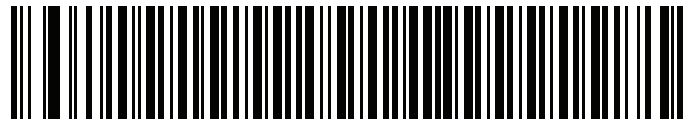

Code 128 - Two Discrete Lengths

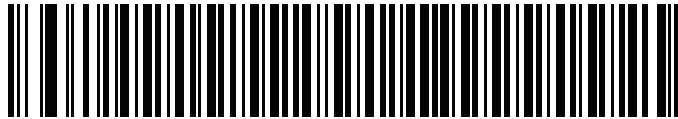

Code 128 - Length Within Range

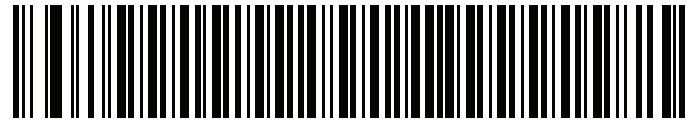

\*Code 128 - Any Length



**Enable/Disable GS1-128 (formerly UCC/EAN-128)**

To enable or disable GS1-128, scan the appropriate bar code below.

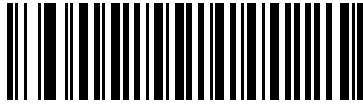

**\*Enable GS1-128**

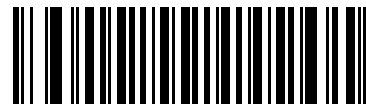

**Disable GS1-128**

**Enable/Disable ISBT 128**

To enable or disable ISBT 128, scan the appropriate bar code below.



**\*Enable ISBT 128**

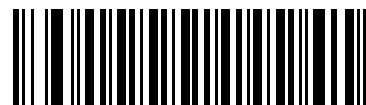

**Disable ISBT 128**

## ISBT Concatenation

Select an option for concatenating pairs of ISBT code types:

- If you select **Disable ISBT Concatenation**, the digital scanner does not concatenate pairs of ISBT codes it encounters.
- If you select **Enable ISBT Concatenation**, there must be two ISBT codes in order for the digital scanner to decode and perform concatenation. The digital scanner does not decode single ISBT symbols.
- If you select **Autodiscriminate ISBT Concatenation**, the digital scanner decodes and concatenates pairs of ISBT codes immediately. If only a single ISBT symbol is present, the digital scanner must decode the symbol the number of times set via [ISBT Concatenation Redundancy on page 13-27](#) before transmitting its data to confirm that there is no additional ISBT symbol.



\*Disable ISBT Concatenation



Enable ISBT Concatenation



Autodiscriminate ISBT Concatenation

## Check ISBT Table

The ISBT specification includes a table that lists several types of ISBT bar codes that are commonly used in pairs. If you set **ISBT Concatenation** to **Enable**, enable **Check ISBT Table** to concatenate only those pairs found in this table. Other types of ISBT codes are not concatenated.



\*Enable Check ISBT Table



Disable Check ISBT Table

## ISBT Concatenation Redundancy

If you set **ISBT Concatenation** to **Autodiscriminate**, use this parameter to set the number of times the digital scanner must decode an ISBT symbol before determining that there is no additional symbol.

Scan the bar code below, then scan two numeric bar codes in [Appendix D, Numeric Bar Codes](#) to set a value between 2 and 20. Enter a leading zero for single digit numbers. To correct an error or change a selection, scan [Cancel on page D-3](#). The default is 10.



ISBT Concatenation Redundancy

---

## Code 39

### Enable/Disable Code 39

To enable or disable Code 39, scan the appropriate bar code below.

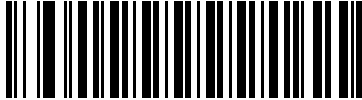

**\*Enable Code 39**

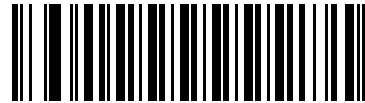

**Disable Code 39**

### Enable/Disable Trioptic Code 39

Trioptic Code 39 is a variant of Code 39 used for marking computer tape cartridges. Trioptic Code 39 symbols always contain six characters. To enable or disable Trioptic Code 39, scan the appropriate bar code below.

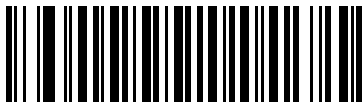

**Enable Trioptic Code 39**



**\*Disable Trioptic Code 39**



**NOTE** You cannot enable Trioptic Code 39 and Code 39 Full ASCII simultaneously.

## Convert Code 39 to Code 32

Code 32 is a variant of Code 39 used by the Italian pharmaceutical industry. Scan the appropriate bar code below to enable or disable converting Code 39 to Code 32.

✓ **NOTE** Code 39 must be enabled for this parameter to function.

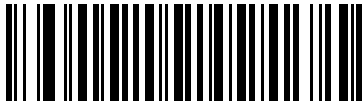

**Convert Code 39 to Code 32  
(Enable)**

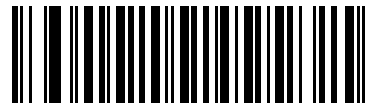

**\*Do Not Convert Code 39 to Code 32  
(Disable)**

## Code 32 Prefix

Scan the appropriate bar code to enable or disable adding the prefix character “A” to all Code 32 bar codes.

✓ **NOTE** Convert Code 39 to Code 32 must be enabled for this parameter to function.



**Enable Code 32 Prefix**

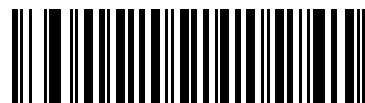

**\*Disable Code 32 Prefix**

## Set Lengths for Code 39

The length of a code refers to the number of characters (i.e., human readable characters), including check digit(s) the code contains. Set lengths for Code 39 for any length, one or two discrete lengths, or lengths within a specific range. If Code 39 Full ASCII is enabled, **Length Within a Range** or **Any Length** are the preferred options.

✓ **NOTE** When setting lengths for different bar code types, enter a leading zero for single digit numbers.

**One Discrete Length** - This option allows the digital scanner to decode only those Code 39 symbols containing a selected length. Use the numeric bar codes in [Appendix D, Numeric Bar Codes](#) to select the length. For example, to decode only Code 39 symbols with 14 characters, scan **Code 39 - One Discrete Length**, then scan **1** followed by **4**. In case of an error, or to change the selection, scan **Cancel** on [page D-3](#).

**Two Discrete Lengths** - This option allows the digital scanner to decode only those Code 39 symbols containing either of two selected lengths. Use the numeric bar codes in [Appendix D, Numeric Bar Codes](#) to select lengths. For example, to decode only Code 39 symbols containing either 2 or 14 characters, select **Code 39 - Two Discrete Lengths**, then scan **0, 2, 1**, and then **4**. In case of an error, or to change the selection, scan **Cancel** on [page D-3](#).

**Length Within Range** - This option allows the digital scanner to decode a Code 39 symbol within a specific length range. Use the numeric bar codes in [Appendix D, Numeric Bar Codes](#) to select the length range. For example, to decode Code 39 symbols containing between 4 and 12 characters, first scan **Code 39 - Length Within Range**. Then scan **0, 4, 1**, and **2** (enter a leading zero for single digit numbers). In case of an error, or to change the selection, scan **Cancel** on [page D-3](#).

**Any Length** - This option allows the digital scanner to decode Code 39 symbols containing any number of characters within the digital scanner's capability.

### Set Lengths for Code 39 (continued)



Code 39 - One Discrete Length



Code 39 - Two Discrete Lengths



Code 39 - Length Within Range



Code 39 - Any Length

## Code 39 Check Digit Verification

Enable this feature to check the integrity of all Code 39 symbols to verify that the data complies with a specified check digit algorithm. The digital scanner decodes only those Code 39 symbols that include a modulo 43 check digit. Enable this feature only if the Code 39 symbols contain a modulo 43 check digit.

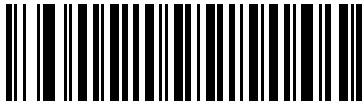

**Enable Code 39 Check Digit**

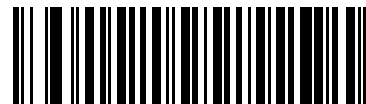

**\*Disable Code 39 Check Digit**

## Transmit Code 39 Check Digit

Scan a bar code below to transmit Code 39 data with or without the check digit.

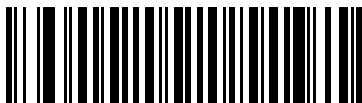

**Transmit Code 39 Check Digit  
(Enable)**



**\*Do Not Transmit Code 39 Check Digit  
(Disable)**



**NOTE** Code 39 Check Digit Verification must be enabled for this parameter to function.



## Code 39 Full ASCII Conversion

Code 39 Full ASCII is a variant of Code 39 that pairs characters to encode the full ASCII character set. To enable or disable Code 39 Full ASCII, scan the appropriate bar code below.

Mapping Code 39 characters to ASCII values is host dependent. For keyboard wedge host conversion, see [Table 6-2 on page 6-14](#). For RS-232 host conversion, see [Table 7-4 on page 7-20](#). For USB host conversion, see [Table 8-2 on page 8-11](#).

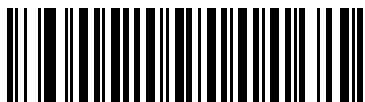

**Enable Code 39 Full ASCII**

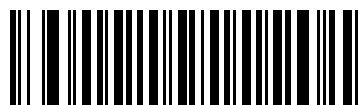

**\*Disable Code 39 Full ASCII**



**NOTE** You cannot enable Trioptic Code 39 and Code 39 Full ASCII simultaneously.

## Code 39 Buffering (Scan & Store)

This feature allows the digital scanner to accumulate data from multiple Code 39 symbols.

Select **Buffer Code 39** to temporarily buffer all Code 39 symbols with a leading space as a first character for later transmission. The leading space is not buffered. Since this feature affects Code 39 only, for best performance configure the digital scanner to decode the Code 39 symbology only.

Decoding a valid Code 39 symbol with no leading space transmits in sequence all buffered data in a first-in first-out format, plus the “triggering” symbol. See the following pages for further details.

Select **Do Not Buffer Code 39** to transmit all decoded Code 39 symbols immediately without storing in the buffer.

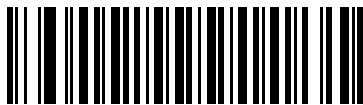

**Buffer Code 39  
(Enable)**

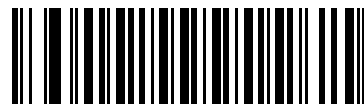

**\*Do Not Buffer Code 39  
(Disable)**

While there is data in the transmission buffer, you cannot select **Do Not Buffer Code 39**. The buffer holds 200 bytes of information.

To disable Code 39 buffering when there is data in the transmission buffer, first force the buffer transmission (see [Transmitting Buffer on page 13-35](#)) or clear the buffer.

### Buffering Data

To buffer data, enable Code 39 buffering and read a Code 39 symbol with a space immediately following the start pattern.

- Unless the data overflows the transmission buffer, the digital scanner issues a low-high beep to indicate successful decode and buffering. For overflow conditions, see [Overfilling Transmission Buffer](#).
- The digital scanner adds the decoded data excluding the leading space to the transmission buffer.
- No transmission occurs.

## Clearing Transmission Buffer

To clear the transmission buffer, scan the **Clear Buffer** bar code below, which contains only a start character, a dash (minus), and a stop character. The digital scanner issues a short high-low-high beep and erases the transmission buffer.



**Clear Buffer**

- ✓ **NOTE** Because the **Clear Buffer** bar code contains only the dash (minus) character, set the Code 39 length to include length 1 before scanning this bar code.

## Transmitting Buffer

There are two methods to transmit the Code 39 buffer:

- Scan the **Transmit Buffer** bar code, which includes only a start character, a plus (+), and a stop character. The digital scanner transmits and clears the buffer, and issues a low-high beep.



**Transmit Buffer**

- Scan a Code 39 bar code with a leading character other than a space. The digital scanner appends the new decode data to the buffered data, transmits and clears the buffer, and issues a low-high beep to signal that the buffer was transmitted.
- ✓ **NOTE** Because the **Transmit Buffer** bar code contains only a plus (+) character, set the Code 39 length to include length 1 before scanning this bar code.

## Overfilling Transmission Buffer

The Code 39 buffer holds 200 characters. If the symbol just read overflows the transmission buffer, the digital scanner issues three long high beeps to indicate it rejected the symbol, and no transmission occurs. The data in the buffer is not affected.

## Attempt to Transmit an Empty Buffer

If the symbol just read was the **Transmit Buffer** symbol and the Code 39 buffer is empty, the digital scanner issues a short low-high-low beep to signal that the buffer is empty, and no transmission occurs. The buffer remains empty.

---

## Code 93

### Enable/Disable Code 93

To enable or disable Code 93, scan the appropriate bar code below.

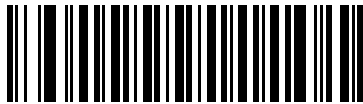

Enable Code 93



\*Disable Code 93

### Set Lengths for Code 93

The length of a code refers to the number of characters (i.e., human readable characters), including check digit(s) the code contains. Set lengths for Code 93 for any length, one or two discrete lengths, or lengths within a specific range.

**One Discrete Length** - This option allows the digital scanner to decode only those Code 93 symbols containing a selected length. Use the numeric bar codes in [Appendix D, Numeric Bar Codes](#) to select the length. For example, to decode only Code 93 symbols with 14 characters, scan **Code 93 - One Discrete Length**, then scan **1** followed by **4**. In case of an error, or to change the selection, scan **Cancel** on [page D-3](#).

**Two Discrete Lengths** - This option allows the digital scanner to decode only those Code 93 symbols containing either of two selected lengths. Use the numeric bar codes in [Appendix D, Numeric Bar Codes](#) to select lengths. For example, to decode only Code 93 symbols containing either 2 or 14 characters, select **Code 93 - Two Discrete Lengths**, then scan **0, 2, 1**, and then **4**. In case of an error, or to change the selection, scan **Cancel** on [page D-3](#).

**Length Within Range** - This option allows the digital scanner to decode a Code 93 symbol within a specific length range. Use the numeric bar codes in [Appendix D, Numeric Bar Codes](#) to select the length range. For example, to decode Code 93 symbols containing between 4 and 12 characters, first scan **Code 93 - Length Within Range**. Then scan **0, 4, 1**, and **2** (insert a leading zero for single digit numbers). In case of an error, or to change the selection, scan **Cancel** on [page D-3](#).

**Any Length** - This option allows the digital scanner to decode Code 93 symbols containing any number of characters within the digital scanner's capability.

### Set Lengths for Code 93 (continued)



Code 93 - One Discrete Length



Code 93 - Two Discrete Lengths



Code 93 - Length Within Range



Code 93 - Any Length

---

## Code 11

### Code 11

To enable or disable Code 11, scan the appropriate bar code below.

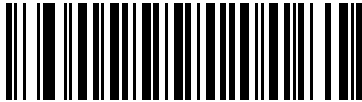

Enable Code 11



\*Disable Code 11

### Set Lengths for Code 11

The length of a code refers to the number of characters (i.e., human readable characters), including check digit(s) the code contains. Set lengths for Code 11 for any length, one or two discrete lengths, or lengths within a specific range.

**One Discrete Length** - This option allows the digital scanner to decode only those Code 11 symbols containing a selected length. Use the numeric bar codes in [Appendix D, Numeric Bar Codes](#) to select the length. For example, to decode only Code 11 symbols with 14 characters, scan **Code 11 - One Discrete Length**, then scan **1** followed by **4**. In case of an error, or to change the selection, scan **Cancel** on [page D-3](#).

**Two Discrete Lengths** - This option allows the digital scanner to decode only those Code 11 symbols containing either of two selected lengths. Use the numeric bar codes in [Appendix D, Numeric Bar Codes](#) to select lengths. For example, to decode only Code 11 symbols containing either 2 or 14 characters, select **Code 11 - Two Discrete Lengths**, then scan **0, 2, 1**, and then **4**. In case of an error, or to change the selection, scan **Cancel** on [page D-3](#).

**Length Within Range** - This option allows the digital scanner to decode a Code 11 symbol within a specific length range. Use the numeric bar codes in [Appendix D, Numeric Bar Codes](#) to select the length range. For example, to decode Code 11 symbols containing between 4 and 12 characters, first scan **Code 11 - Length Within Range**. Then scan **0, 4, 1**, and **2** (insert a leading zero for single digit numbers). In case of an error, or to change the selection, scan **Cancel** on [page D-3](#).

**Any Length** - This option allows the digital scanner to decode Code 11 symbols containing any number of characters within the digital scanner's capability.

**Set Lengths for Code 11 (continued)**



**Code 11 - One Discrete Length**



**Code 11 - Two Discrete Lengths**



**Code 11 - Length Within Range**



**Code 11 - Any Length**

## Code 11 Check Digit Verification

Enable this feature to check the integrity of all Code 11 symbols to verify that the data complies with the specified check digit algorithm. This selects the check digit mechanism for the decoded Code 11 bar code. The options are to check for one check digit, check for two check digits, or disable the feature.

To enable this feature, scan the bar code below corresponding to the number of check digits encoded in the Code 11 symbols.

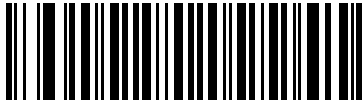

**\*Disable**



**One Check Digit**

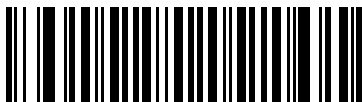

**Two Check Digits**



## Transmit Code 11 Check Digits

This feature selects whether or not to transmit the Code 11 check digit(s).



**Transmit Code 11 Check Digit(s)  
(Enable)**

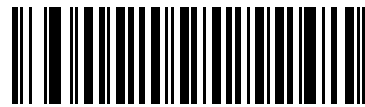

**\*Do Not Transmit Code 11 Check Digit(s)  
(Disable)**



**NOTE** Code 11 Check Digit Verification must be enabled for this parameter to function.

## Interleaved 2 of 5 (I 2 of 5)

### Enable/Disable Interleaved 2 of 5

To enable or disable Interleaved 2 of 5, scan the appropriate bar code below, and select an Interleaved 2 of 5 length.

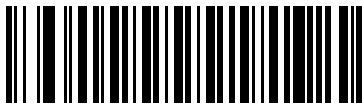

\*Enable Interleaved 2 of 5



Disable Interleaved 2 of 5

### Set Lengths for Interleaved 2 of 5

The length of a code refers to the number of characters (i.e., human readable characters), including check digit(s) the code contains. Set lengths for I 2 of 5 for any length, one or two discrete lengths, or lengths within a specific range.

**One Discrete Length** - This option allows the digital scanner to decode only those I 2 of 5 symbols containing a selected length. Use the numeric bar codes in [Appendix D, Numeric Bar Codes](#) to select the length. For example, to decode only I 2 of 5 symbols with 14 characters, scan **I 2 of 5 - One Discrete Length**, then scan **1** followed by **4**. In case of an error, or to change the selection, scan **Cancel** on [page D-3](#).

**Two Discrete Lengths** - This option allows the digital scanner to decode only those I 2 of 5 symbols containing either of two selected lengths. Use the numeric bar codes in [Appendix D, Numeric Bar Codes](#) to select lengths. For example, to decode only I 2 of 5 symbols containing either 2 or 14 characters, select **I 2 of 5 - Two Discrete Lengths**, then scan **0, 2, 1**, and then **4**. In case of an error, or to change the selection, scan **Cancel** on [page D-3](#).

**Length Within Range** - This option allows the digital scanner to decode an I 2 of 5 symbol within a specific length range. Use the numeric bar codes in [Appendix D, Numeric Bar Codes](#) to select the length range. For example, to decode I 2 of 5 symbols containing between 4 and 12 characters, first scan **I 2 of 5 - Length Within Range**. Then scan **0, 4, 1**, and **2** (insert a leading zero for single digit numbers). In case of an error, or to change the selection, scan **Cancel** on [page D-3](#).

**Any Length** - This option allows the digital scanner to decode I 2 of 5 symbols containing any number of characters within the digital scanner's capability.



**NOTE** Due to the construction of the I 2 of 5 symbology, the digital scanner can interpret a scan line covering only a portion of the code as a complete scan, yielding less data than is encoded in the bar code. To prevent this, select specific lengths (I 2 of 5 - One Discrete Length, Two Discrete Lengths) for I 2 of 5 applications.

### Set Lengths for Interleaved 2 of 5 (continued)



I 2 of 5 - One Discrete Length



I 2 of 5 - Two Discrete Lengths



I 2 of 5 - Length Within Range



I 2 of 5 - Any Length

## I 2 of 5 Check Digit Verification

Enable this feature to check the integrity of all I 2 of 5 symbols to verify that the data complies with either the specified Uniform Symbology Specification (USS), or the Optical Product Code Council (OPCC) check digit algorithm.



**\*Disable**



**USS Check Digit**



**OPCC Check Digit**

## Transmit I 2 of 5 Check Digit

Scan the appropriate bar code below to transmit I 2 of 5 data with or without the check digit.

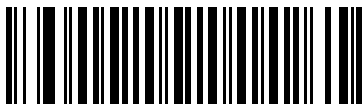

**Transmit I 2 of 5 Check Digit  
(Enable)**

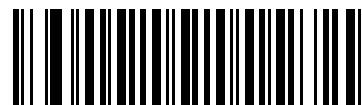

**\*Do Not Transmit I 2 of 5 Check Digit  
(Disable)**

## Convert I 2 of 5 to EAN-13

This parameter converts a 14 character I 2 of 5 code into EAN-13, and transmits to the host as EAN-13. Before enabling this, first enable the I 2 of 5 symbology. The code must include a leading zero and a valid EAN-13 check digit.

To enable this feature, scan **Convert I 2 of 5 to EAN-13 (Enable)**.

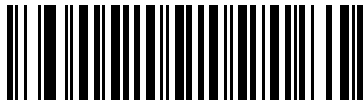

**Convert I 2 of 5 to EAN-13  
(Enable)**



**\*Do Not Convert I 2 of 5 to EAN-13  
(Disable)**

## Discrete 2 of 5 (D 2 of 5)

### Enable/Disable Discrete 2 of 5

To enable or disable Discrete 2 of 5, scan the appropriate bar code below.

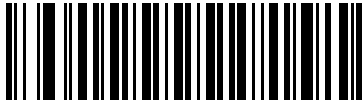

Enable Discrete 2 of 5



\*Disable Discrete 2 of 5

### Set Lengths for Discrete 2 of 5

The length of a code refers to the number of characters (i.e., human readable characters), including check digit(s) the code contains. Set lengths for D 2 of 5 for any length, one or two discrete lengths, or lengths within a specific range.

**One Discrete Length** - This option allows the digital scanner to decode only those D 2 of 5 symbols containing a selected length. Use the numeric bar codes in [Appendix D, Numeric Bar Codes](#) to select the length. For example, to decode only D 2 of 5 symbols with 14 characters, scan **D 2 of 5 - One Discrete Length**, then scan **1** followed by **4**. In case of an error, or to change the selection, scan **Cancel** on [page D-3](#).

**Two Discrete Lengths** - This option allows the digital scanner to decode only those D 2 of 5 symbols containing either of two selected lengths. Use the numeric bar codes in [Appendix D, Numeric Bar Codes](#) to select lengths. For example, to decode only D 2 of 5 symbols containing either 2 or 14 characters, select **D 2 of 5 - Two Discrete Lengths**, then scan **0, 2, 1**, and then **4**. In case of an error, or to change the selection, scan **Cancel** on [page D-3](#).

**Length Within Range** - This option allows the digital scanner to decode a D 2 of 5 symbol within a specific length range. Use the numeric bar codes in [Appendix D, Numeric Bar Codes](#) to select the length range. For example, to decode D 2 of 5 symbols containing between 4 and 12 characters, first scan **D 2 of 5 - Length Within Range**. Then scan **0, 4, 1**, and **2** (insert a leading zero for single digit numbers). In case of an error, or to change the selection, scan **Cancel** on [page D-3](#).

**Any Length** - This option allows the digital scanner to decode D 2 of 5 symbols containing any number of characters within the digital scanner's capability.



**NOTE** Due to the construction of the D 2 of 5 symbology, the digital scanner can interpret a scan line covering only a portion of the code as a complete scan, yielding less data than is encoded in the bar code. To prevent this, select specific lengths (D 2 of 5 - One Discrete Length, Two Discrete Lengths) for D 2 of 5 applications.

### Set Lengths for Discrete 2 of 5 (continued)



D 2 of 5 - One Discrete Length



D 2 of 5 - Two Discrete Lengths



D 2 of 5 - Length Within Range



D 2 of 5 - Any Length

---

## Codabar (NW - 7)

### Enable/Disable Codabar

To enable or disable Codabar, scan the appropriate bar code below.

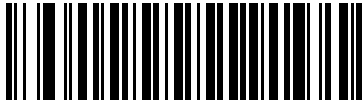

Enable Codabar



\*Disable Codabar

### Set Lengths for Codabar

The length of a code refers to the number of characters (i.e., human readable characters), including check digit(s) the code contains. Set lengths for Codabar for any length, one or two discrete lengths, or lengths within a specific range.

**One Discrete Length** - This option allows the digital scanner to decode only those Codabar symbols containing a selected length. Use the numeric bar codes in [Appendix D, Numeric Bar Codes](#) to select the length. For example, to decode only Codabar symbols with 14 characters, scan **Codabar - One Discrete Length**, then scan **1** followed by **4**. In case of an error, or to change the selection, scan **Cancel** on [page D-3](#).

**Two Discrete Lengths** - This option allows the digital scanner to decode only those Codabar symbols containing either of two selected lengths. Use the numeric bar codes in [Appendix D, Numeric Bar Codes](#) to select lengths. For example, to decode only Codabar symbols containing either 2 or 14 characters, select **Codabar - Two Discrete Lengths**, then scan **0, 2, 1**, and then **4**. In case of an error, or to change the selection, scan **Cancel** on [page D-3](#).

**Length Within Range** - This option allows the digital scanner to decode a Codabar symbol within a specific length range. Use the numeric bar codes in [Appendix D, Numeric Bar Codes](#) to select the length range. For example, to decode Codabar symbols containing between 4 and 12 characters, first scan **Codabar - Length Within Range**. Then scan **0, 4, 1**, and **2** (insert a leading zero for single digit numbers). In case of an error, or to change the selection, scan **Cancel** on [page D-3](#).

**Any Length** - This option allows the digital scanner to decode Codabar symbols containing any number of characters within the digital scanner's capability.



### Set Lengths for Codabar (continued)



Codabar - One Discrete Length



Codabar - Two Discrete Lengths



Codabar - Length Within Range



Codabar - Any Length

## CLSI Editing

Enable this parameter to strip the start and stop characters and insert a space after the first, fifth, and tenth characters of a 14-character Codabar symbol. Enable this feature if the host system requires this data format.

✓ **NOTE** Symbol length does not include start and stop characters.



**Enable CLSI Editing**

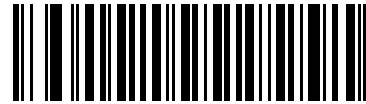

**\*Disable CLSI Editing**

## NOTIS Editing

Enable this parameter to strip the start and stop characters from a decoded Codabar symbol. Enable this feature if the host system requires this data format.

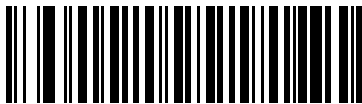

**Enable NOTIS Editing**

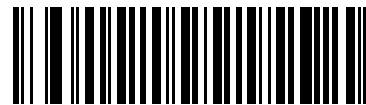

**\*Disable NOTIS Editing**

---

## MSI

### Enable/Disable MSI

To enable or disable MSI, scan the appropriate bar code below.



Enable MSI

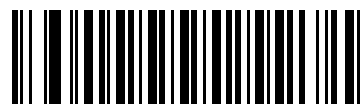

\*Disable MSI

### Set Lengths for MSI

The length of a code refers to the number of characters (i.e., human readable characters), including check digit(s) the code contains. Set lengths for MSI for any length, one or two discrete lengths, or lengths within a specific range.

**One Discrete Length** - This option allows the digital scanner to decode only those MSI symbols containing a selected length. Use the numeric bar codes in [Appendix D, Numeric Bar Codes](#) to select the length. For example, to decode only MSI symbols with 14 characters, scan **MSI - One Discrete Length**, then scan **1** followed by **4**. In case of an error, or to change the selection, scan **Cancel** on [page D-3](#).

**Two Discrete Lengths** - This option allows the digital scanner to decode only those MSI symbols containing either of two selected lengths. Use the numeric bar codes in [Appendix D, Numeric Bar Codes](#) to select lengths. For example, to decode only MSI symbols containing either 2 or 14 characters, select **MSI - Two Discrete Lengths**, then scan **0, 2, 1**, and then **4**. In case of an error, or to change the selection, scan **Cancel** on [page D-3](#).

**Length Within Range** - This option allows the digital scanner to decode an MSI symbol within a specific length range. Use the numeric bar codes in [Appendix D, Numeric Bar Codes](#) to select the length range. For example, to decode MSI symbols containing between 4 and 12 characters, first scan **MSI - Length Within Range**. Then scan **0, 4, 1**, and **2** (insert a leading zero for single digit numbers). In case of an error, or to change the selection, scan **Cancel** on [page D-3](#).

**Any Length** - This option allows the digital scanner to decode MSI symbols containing any number of characters within the digital scanner's capability.



**NOTE** Due to the construction of the MSI symbology, the digital scanner can interpret a scan line covering only a portion of the code as a complete scan, yielding less data than is encoded in the bar code. To prevent this, select specific lengths (MSI - One Discrete Length, Two Discrete Lengths) for MSI applications.

### Set Lengths for MSI (continued)



**MSI - One Discrete Length**



**MSI - Two Discrete Lengths**



**MSI - Length Within Range**



**MSI - Any Length**

## MSI Check Digits

With MSI symbols, one check digit is mandatory and always verified by the reader. The second check digit is optional. If the MSI codes include two check digits, enable the verification of the second check digit by scanning the bar code below.

See [MSI Check Digit Algorithm on page 13-54](#) for the selection of second digit algorithms.

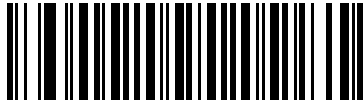

**\*One MSI Check Digit**

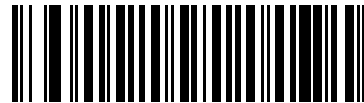

**Two MSI Check Digits**

## Transmit MSI Check Digit(s)

Scan a bar code below to transmit MSI data with or without the check digit.

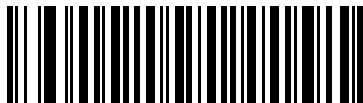

**Transmit MSI Check Digit(s)  
(Enable)**



**\*Do Not Transmit MSI Check Digit(s)  
(Disable)**

## MSI Check Digit Algorithm

Two algorithms are possible for the verification of the second MSI check digit. Select the bar code below corresponding to the algorithm used to encode the check digit.

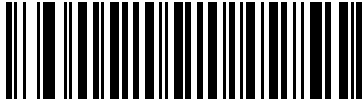

MOD 10/MOD 11



\*MOD 10/MOD 10

---

## Chinese 2 of 5

### Enable/Disable Chinese 2 of 5

To enable or disable Chinese 2 of 5, scan the appropriate bar code below.



Enable Chinese 2 of 5



\*Disable Chinese 2 of 5

---

## Matrix 2 of 5

### Enable/Disable Matrix 2 of 5

To enable or disable Matrix 2 of 5, scan the appropriate bar code below.



**Enable Matrix 2 of 5**



**\*Disable Matrix 2 of 5**

## Set Lengths for Matrix 2 of 5

The length of a code refers to the number of characters (i.e., human readable characters), including check digit(s) the code contains. Set lengths for Matrix 2 of 5 to any length, one or two discrete lengths, or lengths within a specific range.

- **One Discrete Length** - Select this option to decode only Matrix 2 of 5 symbols containing a selected length. Select the length using the numeric bar codes in [Appendix D, Numeric Bar Codes](#). For example, to decode only Matrix 2 of 5 symbols with 14 characters, scan **Matrix 2 of 5 - One Discrete Length**, then scan **1** followed by **4**. To correct an error or to change the selection, scan [Cancel on page D-3](#).
- **Two Discrete Lengths** - Select this option to decode only Matrix 2 of 5 symbols containing either of two selected lengths. Select lengths using the numeric bar codes in [Appendix D, Numeric Bar Codes](#). For example, to decode only Matrix 2 of 5 symbols containing either 2 or 14 characters, select **Matrix 2 of 5 - Two Discrete Lengths**, then scan **0, 2, 1**, and then **4**. To correct an error or to change the selection, scan [Cancel on page D-3](#).
- **Length Within Range** - Select this option to decode a Matrix 2 of 5 symbol with a specific length range. Select lengths using the numeric bar codes in [Appendix D, Numeric Bar Codes](#). For example, to decode Matrix 2 of 5 symbols containing between 4 and 12 characters, first scan **Matrix 2 of 5 - Length Within Range**. Then scan **0, 4, 1**, and **2** (enter a leading zero for single digit numbers). To correct an error or change the selection, scan [Cancel on page D-3](#).
- **Any Length** - Scan this option to decode Matrix 2 of 5 symbols containing any number of characters within the digital scanner's capability.



\*Matrix 2 of 5 - One Discrete Length



Matrix 2 of 5 - Two Discrete Lengths



Matrix 2 of 5 - Length Within Range



Matrix 2 of 5 - Any Length



## Matrix 2 of 5 Redundancy

To enable or disable Matrix 2 of 5 redundancy, scan the appropriate bar code below.



**Enable Matrix 2 of 5 Redundancy**



**\*Disable Matrix 2 of 5 Redundancy**

## Matrix 2 of 5 Check Digit

The check digit is the last character of the symbol used to verify the integrity of the data. Scan the appropriate bar code below to transmit the bar code data with or without the Matrix 2 of 5 check digit.



**Enable Matrix 2 of 5 Check Digit**



**\*Disable Matrix 2 of 5 Check Digit**

## Transmit Matrix 2 of 5 Check Digit

Scan a bar code below to transmit Matrix 2 of 5 data with or without the check digit.



Transmit Matrix 2 of 5 Check Digit



\*Do Not Transmit Matrix 2 of 5 Check Digit

---

## Inverse 1D

This parameter sets the 1D inverse decoder setting. Options are:

- **Regular Only** - the scanner decodes regular 1D bar codes only.
- **Inverse Only** - the scanner decodes inverse 1D bar codes only.
- **Inverse Autodetect** - the scanner decodes both regular and inverse 1D bar codes.



\*Regular



Inverse Only



Inverse Autodetect

---

## Postal Codes

### US Postnet

To enable or disable US Postnet, scan the appropriate bar code below.



**\*Enable US Postnet**



**Disable US Postnet**

### US Planet

To enable or disable US Planet, scan the appropriate bar code below.



**\*Enable US Planet**



**Disable US Planet**

## Transmit US Postal Check Digit

Select whether to transmit US Postal data, which includes both US Postnet and US Planet, with or without the check digit.

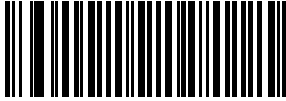

**\*Transmit US Postal Check Digit**

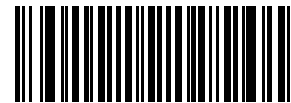

**Do Not Transmit US Postal Check Digit**

## UK Postal

To enable or disable UK Postal, scan the appropriate bar code below.



**\*Enable UK Postal**



**Disable UK Postal**

## Transmit UK Postal Check Digit

Select whether to transmit UK Postal data with or without the check digit.



**\*Transmit UK Postal  
Check Digit**



**Do Not Transmit UK Postal Check Digit**

## Japan Postal

To enable or disable Japan Postal, scan the appropriate bar code below.



**\*Enable Japan Postal**



**Disable Japan Postal**

## Australian Postal

To enable or disable Australian Postal, scan the appropriate bar code below.



**\*Enable Australian Postal**



**Disable Australian Postal**

## Netherlands KIX Code

To enable or disable Netherlands KIX Code, scan the appropriate bar code below.



**\*Enable Netherlands KIX Code**



**Disable Netherlands KIX Code**

## USPS 4CB/One Code/Intelligent Mail

To enable or disable USPS 4CB/One Code/Intelligent Mail, scan the appropriate bar code below.



Enable USPS 4CB/One Code/Intelligent Mail



\*Disable USPS 4CB/One Code/Intelligent Mail

## UPU FICS Postal

To enable or disable UPU FICS Postal, scan the appropriate bar code below.



Enable UPU FICS Postal



\*Disable UPU FICS Postal

---

## GS1 DataBar (formerly RSS - Reduced Space Symbology)

The variants of GS1 DataBar are DataBar-14, DataBar Expanded, and DataBar Limited. The limited and expanded versions have stacked variants. Scan the appropriate bar codes to enable or disable each variant of GS1 DataBar.

### GS1 DataBar-14

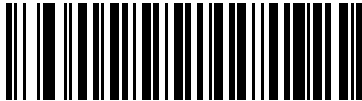

**\*Enable GS1 DataBar-14**

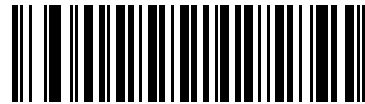

**Disable GS1 DataBar-14**

### GS1 DataBar Limited

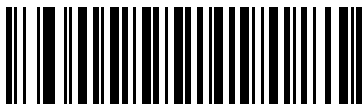

**\*Enable GS1 DataBar Limited**



**Disable GS1 DataBar Limited**



## GS1 DataBar Expanded

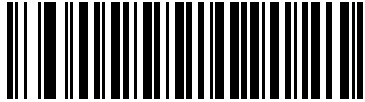

**\*Enable GS1 DataBar Expanded**

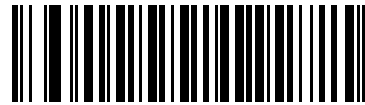

**Disable GS1 DataBar Expanded**

## Convert GS1 DataBar to UPC/EAN

This parameter only applies to DataBar-14 and GS1 DataBar Limited symbols not decoded as part of a composite symbol. Enable this conversion to strip the leading '010' from DataBar-14 and GS1 DataBar Limited symbols encoding a single zero as the first digit, and report the bar code as EAN-13.

When the digital scanner decodes bar codes beginning with two or more zeros but not six zeros, it strips the leading '0100' and reports the bar code as UPC-A. The UPC-A Preamble parameter to transmit the system character and country code applies to converted bar codes. Note that the digital scanner cannot strip the system character or the check digit.



**Enable Convert GS1 DataBar to UPC/EAN**



**\*Disable Convert GS1 DataBar to UPC/EAN**

---

## Composite

### Composite CC-C

Scan a bar code below to enable or disable Composite bar codes of type CC-C.

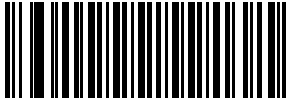

Enable CC-C

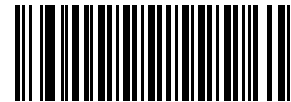

\*Disable CC-C

### Composite CC-A/B

Scan a bar code below to enable or disable Composite bar codes of type CC-A/B.



Enable CC-A/B



\*Disable CC-A/B

## Composite TLC-39

Scan a bar code below to enable or disable Composite bar codes of type TLC-39.

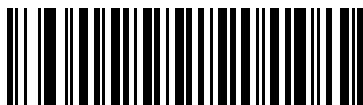

**Enable TLC39**



**\*Disable TLC39**

## UPC Composite Mode

Select an option for linking UPC symbols with a 2D symbol during transmission as if they were one symbol:

- Select **UPC Never Linked** to transmit UPC bar codes regardless of whether a 2D symbol is detected.
- Select **UPC Always Linked** to transmit UPC bar codes and the 2D portion. If 2D is not present, the UPC bar code does not transmit.
- If **Autodiscriminate UPC Composites** is selected, the scanner determines if there is a 2D portion, then transmits the UPC as well as the 2D portion if present.



**UPC Never Linked**



**\*UPC Always Linked**



**Autodiscriminate UPC Composites**

## **GS1-128 Emulation Mode for UCC/EAN Composite Codes**

Scan one of the following bar codes to enable or disable this mode. Enable this to transmit composite bar codes as GS1-128 bar codes as per the AIM specification for UCC/EAN Composite Codes.



**Enable GS1-128 Emulation Mode for  
UCC/EAN Composite Codes**



**\*Disable GS1-128 Emulation Mode for  
UCC/EAN Composite Codes**

---

## 2D Symbologies

### Enable/Disable PDF417

To enable or disable PDF417, scan the appropriate bar code below.



**\*Enable PDF417**



**Disable PDF417**

### Enable/Disable MicroPDF417

To enable or disable MicroPDF417, scan the appropriate bar code below.



**Enable MicroPDF417**



**\*Disable MicroPDF417**

## Code 128 Emulation

Enable this parameter to transmits data from certain MicroPDF417 symbols as if it was encoded in Code 128 symbols. Transmit AIM Symbology Identifiers must be enabled for this parameter to work.

Enable Code 128 Emulation to transmit these MicroPDF417 symbols with one of the following prefixes:

- ]C1 if the first codeword is 903-905
- ]C2 if the first codeword is 908 or 909
- ]C0 if the first codeword is 910 or 911

Disable Code 128 Emulation to transmit these MicroPDF417 symbols with one of the following prefixes:

- ]L3 if the first codeword is 903-905
- ]L4 if the first codeword is 908 or 909
- ]L5 if the first codeword is 910 or 911

Scan a bar code below to enable or disable Code 128 Emulation.



**NOTE** Linked MicroPDF codewords 906, 907, 912, 914, and 915 are not supported. Use GS1 Composites instead.



**Enable Code 128 Emulation**



**\*Disable Code 128 Emulation**

## Data Matrix

To enable or disable Data Matrix, scan the appropriate bar code below.



\*Enable Data Matrix



Disable Data Matrix

## Data Matrix Inverse

This parameter sets the Data Matrix inverse decoder setting. Options are:

- **Regular Only** - the scanner decodes regular Data Matrix bar codes only.
- **Inverse Only** - the scanner decodes inverse Data Matrix bar codes only.
- **Inverse Autodetect** - the scanner decodes both regular and inverse Data Matrix bar codes.



**NOTE** If you enable [DPM Scanning on page 5-5](#), the scanner behaves as if the **Inverse Autodetect** setting is selected. When you disable DPM Scanning, the previous (user-selected) **Data Matrix Inverse** setting remains in effect.



\*Regular



Inverse Only



Inverse Autodetect

## Maxicode

To enable or disable Maxicode, scan the appropriate bar code below.



**\*Enable Maxicode**



**Disable Maxicode**



## QR Code

To enable or disable QR Code, scan the appropriate bar code below.



**\*Enable QR Code**



**Disable QR Code**

## QR Inverse

This parameter sets the QR inverse decoder setting. Options are:

- **Regular Only** - the scanner decodes regular QR bar codes only.
- **Inverse Only** - the scanner decodes inverse QR bar codes only.
- **Inverse Autodetect** - the scanner decodes both regular and inverse QR bar codes.



**\*Regular**



**Inverse Only**



**Inverse Autodetect**

## MicroQR

To enable or disable MicroQR, scan the appropriate bar code below.



**\*Enable MicroQR**



**Disable MicroQR**

## Aztec

To enable or disable Aztec, scan the appropriate bar code below.



\*Enable Aztec



Disable Aztec

## Aztec Inverse

This parameter sets the Aztec inverse decoder setting. Options are:

- **Regular Only** - the scanner decodes regular Aztec bar codes only.
- **Inverse Only** - the scanner decodes inverse Aztec bar codes only.
- **Inverse Autodetect** - the scanner decodes both regular and inverse Aztec bar codes.



\*Regular



Inverse Only



Inverse Autodetect

## Redundancy Level

The digital scanner offers four levels of decode redundancy. Select higher redundancy levels for lower quality bar codes. As redundancy levels increase, the digital scanner's aggressiveness decreases.

Select the redundancy level appropriate for the bar code quality.

### Redundancy Level 1

The digital scanner must successfully read the following code types twice before decode:

Code Type	Code Length
Codabar	8 characters or less
MSI	4 characters or less
D 2 of 5	8 characters or less
I 2 of 5	8 characters or less

### Redundancy Level 2

The digital scanner must successfully read all code types twice before decode.

### Redundancy Level 3

The digital scanner must successfully read code types other than the following twice before decode. It must read the following codes three times:

Code Type	Code Length
MSI Plessey	4 characters or less
D 2 of 5	8 characters or less
I 2 of 5	8 characters or less
Codabar	8 characters or less

### Redundancy Level 4

The digital scanner must successfully read all code types three times before decode.

---

## Redundancy Level (continued)

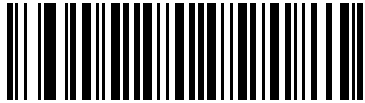

\*Redundancy Level 1

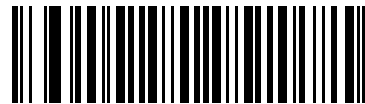

Redundancy Level 2

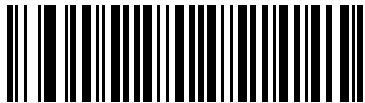

Redundancy Level 3

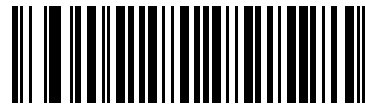

Redundancy Level 4

---

## Security Level

The digital scanner offers four levels of decode security for UPC/EAN bar codes. Select higher security levels for lower quality bar codes. There is an inverse relationship between security and decode speed, so be sure to choose only that level of security necessary for the application.

### Security Level 0

This default setting allows the digital scanner to operate fastest, while providing sufficient security in decoding “in-spec” UPC/EAN bar codes.

### Security Level 1

As bar code quality levels diminish, certain characters become prone to misdecodes before others (i.e., 1, 2, 7, 8). If the digital scanner is misdecoding poorly printed bar codes, and the misdecodes are limited to these characters, select this security level.

### Security Level 2

If the digital scanner is misdecoding poorly printed bar codes, and the misdecodes are not limited to characters 1, 2, 7, and 8, select this security level.

### Security Level 3

If the digital scanner is still misdecoding, select this security level. Be advised, selecting this option is an extreme measure against misdecoding severely out of spec bar codes. Selecting this level of security can significantly impair the decoding ability of the digital scanner. If this level of security is necessary, try to improve the quality of the bar codes.

---

**Security Level (continued)**



**\*Security Level 0**

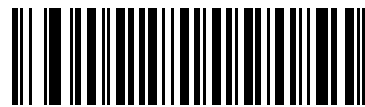

**Security Level 1**

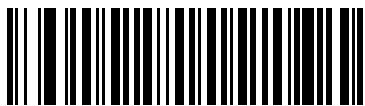

**Security Level 2**

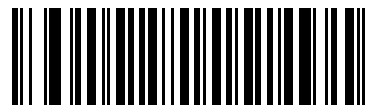

**Security Level 3**

## Intercharacter Gap Size

The Code 39 and Codabar symbologies have an intercharacter gap that is typically quite small. Due to various bar code-printing technologies, this gap can grow larger than the maximum size allowed, preventing the digital scanner from decoding the symbol. If this problem occurs, scan the **Large Intercharacter Gaps** parameter to tolerate these out-of-specification bar codes.



**\*Normal Intercharacter Gaps**



**Large Intercharacter Gaps**



---

## Macro PDF Features

Macro PDF is a special feature for concatenating multiple PDF symbols into one file. The digital scanner can decode symbols that are encoded with this feature, and can store more than 64 kb of decoded data stored in up to 50 MacroPDF symbols.



**CAUTION** When printing, keep each Macro PDF sequence separate, as each sequence has unique identifiers. Do not mix bar codes from several Macro PDF sequences, even if they encode the same data. When scanning Macro PDF sequences, scan the entire sequence without interruption. If, when scanning a mixed sequence, the digital scanner emits two long low beeps (low-low) this indicates an inconsistent file ID or inconsistent symbology error.

### Flush Macro Buffer

This flushes the buffer of all decoded Macro PDF data stored to that point, transmits it to the host device, and aborts from Macro PDF mode.



**Flush Macro PDF Buffer**

### Abort Macro PDF Entry

This clears all currently-stored Macro PDF data in the buffer without transmission and aborts from Macro PDF mode.



**Abort Macro PDF Entry**



# Chapter 14 Miscellaneous Scanner Options

---

## Introduction

This chapter includes bar codes to customize how data transmits to the host device. Also see each host chapter for the appropriate host connections and host device features for the digital scanner. See [Chapter 13, Symbologies](#) and [Chapter 15, Advanced Data Formatting](#) for more options for customizing how data transmits to the host.

Before programming, follow the instructions in [Chapter 1, Getting Started](#).

The digital scanner ships with the settings shown in [Table 14-1](#) (also see [Appendix A, Standard Default Parameters](#) for all host and miscellaneous scanner defaults). If the default values suit requirements, programming is not necessary. Set feature values by scanning single bar codes or short bar code sequences.

---

## Scanning Sequence Examples

In most cases, scan only one bar code to set a parameter value. Other parameters, such as **Prefix Value**, require scanning several bar codes in sequence. See the parameter description for this procedure.

---

## Errors While Scanning

Unless otherwise specified, if you make an error during a scanning sequence, re-scan the correct parameter.

## Miscellaneous Default Parameters

[Table 14-1](#) lists the defaults for miscellaneous scanner options parameters. To change an option, scan the appropriate bar code(s) in this chapter.

✓ **NOTE** See [Appendix A, Standard Default Parameters](#) for all user preference, host, symbology, and miscellaneous default parameters.

**Table 14-1** *Miscellaneous Scanner Options Default Table*

Parameter	Default	Page Number
<b>Miscellaneous Scanner Options</b>		
Transmit Code ID Character	None	<a href="#">14-3</a>
Prefix Value	7013 <CR><LF>	<a href="#">14-4</a>
Suffix 1 Value Suffix 2 Value	7013 <CR><LF>	<a href="#">14-4</a>
Scan Data Transmission Format	Data As Is	<a href="#">14-5</a>
FN1 Substitution Values	Set FN1 Substitution Value	<a href="#">14-6</a>
Transmit "No Read" Message	Disable No Read	<a href="#">14-7</a>
Report Version		<a href="#">14-7</a>

---

## Miscellaneous Scanner Parameters

### Transmit Code ID Character

A code ID character identifies the code type of a scanned bar code. This is useful when the digital scanner is decoding more than one code type. Select a code ID character to insert between the prefix and the decoded symbol.

Select no code ID character, a Symbol code ID character, or an AIM code ID character. For code ID characters, see [Symbol Code Identifiers on page B-1](#) and [AIM Code Identifiers on page B-3](#).

- ✓ **NOTE** If you enable Symbol Code ID Character or AIM Code ID Character, and enable [Transmit "No Read" Message on page 14-7](#), the scanner appends the code ID for Code 39 to the NR message.

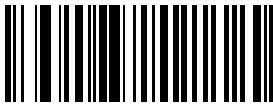

Symbol Code ID Character

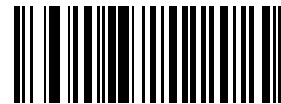

AIM Code ID Character

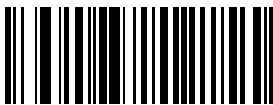

\*None

## Prefix/Suffix Values

To assign a prefix and/or one or two suffix values to append to scan data for use in data editing, scan the appropriate bar code, then scan a four-digit number (i.e., four numeric bar codes) from [Appendix D, Numeric Bar Codes](#) that corresponds to key codes for various terminals. For conversion information, see the ASCII Character Set tables in the appropriate host chapter. To correct an error or change the selection, scan **Cancel** on [page D-3](#).

✓ **NOTE** To use Prefix/Suffix values, set the [Scan Data Transmission Format](#).

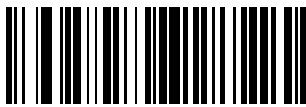

Scan Prefix

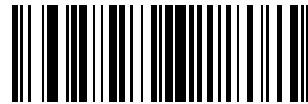

Scan Suffix 1



Scan Suffix 2

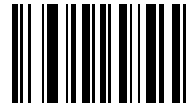

Data Format Cancel

## Scan Data Transmission Format

To change the scan data format, scan one of the following bar codes corresponding to the desired format.

✓ **NOTE** If using this parameter do not use ADF rules to set the prefix/suffix.

To set values for the prefix and/or suffix, see [Prefix/Suffix Values on page 14-4](#).



**\*Data As Is**



**<DATA> <SUFFIX 1>**



**<DATA> <SUFFIX 2>**



**<DATA> <SUFFIX 1> <SUFFIX 2>**



**<PREFIX> <DATA >**

## Scan Data Transmission Format (continued)



<PREFIX> <DATA> <SUFFIX 1>



<PREFIX> <DATA> <SUFFIX 2>



<PREFIX> <DATA> <SUFFIX 1> <SUFFIX 2>

## FN1 Substitution Values

The keyboard wedge and USB HID keyboard hosts support a FN1 Substitution feature. Enable this to replace any FN1 character (0x1b) in a GS1-128 bar code with a defined value. This value defaults to 7013 (Enter Key).

1. To select a FN1 substitution value, scan the following bar code.



**Set FN1 Substitution Value**

2. Enter the 4-digit FN1 substitution (ASCII) value by scanning each digit in [Appendix D, Numeric Bar Codes](#). See the ASCII Character Set table for the host interface.

To correct an error or change the selection, scan [Cancel on page D-3](#).

To enable FN1 Substitution for keyboard wedge, scan the **Enable Keyboard Wedge** FN1 Substitution bar code on [page 6-11](#).

To enable FN1 Substitution for the USB HID keyboard, scan the **Enable USB Keyboard** FN1 Substitution bar code on [page 8-9](#).



## Transmit “No Read” Message

Scan one of the following bar codes to select whether or not to transmit a “No Read” message. Enable this to transmit the characters NR when a bar code does not decode. Disable this to transmit nothing to the host if a symbol does not decode.

- ✓ **NOTE** If you enable **Transmit No Read**, and also enable Symbol Code ID Character or AIM Code ID Character for [Transmit Code ID Character on page 14-3](#), the scanner appends the code ID for Code 39 to the NR message.



**Enable No Read**



**\*Disable No Read**

## Report Version

Scan the bar code below to report the version of software installed in the digital scanner.



**Report Software Version**



# Chapter 15 Advanced Data Formatting

---

## Introduction

Advanced Data Formatting (ADF) is a means of customizing data before transmission to the host device to suit particular requirements.

To implement ADF, scan a related series of bar codes which begin on [page 15-8](#), or use the 123Scan utility (see [Chapter 12, 123Scan](#)) which allows programming the digital scanner with ADF rules.

Avoid using ADF formatting with bar codes containing more than 60 characters. To add a prefix or suffix value for such bar codes, use [Prefix/Suffix Values](#) and [Scan Data Transmission Format on page 14-5](#). Using ADF with longer bar codes transmits the bar code in segments of length 252 or less (depending on the host selected), and applies the rule to each segment.

✓ **NOTE** If using the wand interface with the digital scanner, in order to use ADF rules to format data, first enable [Convert All to Code 39 on page 10-7](#).

---

## Rules: Criteria Linked to Actions

ADF uses rules to customize data. These rules perform detailed actions when the data meets certain criteria. One rule may consist of single or multiple criteria applied to single or multiple actions.

For instance, a data formatting rule could be:

**Criteria:** *When scan data is Code 39, length 12, and data at the start position is the string "129",*

**Actions:** *pad all sends with zeros to length 8,  
send all data up to X,  
send a space.*

If the digital scanner scans a Code 39 bar code of 1299X1559828, it transmits the following: 00001299<space>.

If the digital scanner scans a Code 39 bar code of 1299X15598, it ignores this rule because the bar code didn't meet the length criteria.

The rule specifies the editing conditions and requirements before data transmission occurs.

---

## Creating ADF Rules

When programming a rule, make sure the rule is logically correct. Plan ahead before scanning.

To program each data formatting rule:

- **Start the Rule.** Scan [Begin New Rule on page 15-8](#).
- **Specify Criteria.** Scan the bar codes for all pertinent criteria. Criteria can include code type (e.g., Code 128), code length, or data that contains a specific character string (e.g., the digits “129”). See [Criteria on page 15-11](#) for options.
- **Select Actions.** Scan all actions related to, or affecting, these criteria. The actions of a rule specify how to format the data for transmission. See [Actions on page 15-27](#).
- **Save the Rule.** Scan [Save Rule on page 15-8](#). This places the rule in the “top” position in the rule buffer.

To erase criteria, actions, and entire rules, scan the appropriate bar code on [page 15-9](#).

[Beeper Definitions on page 2-2](#) guide through the programming steps.

---

## ADF Programming Example

This section provides an example of how to enter ADF rules to use for scan data.

An auto parts distribution center wants to encode manufacturer ID, part number, and destination code into their own Code 128 bar codes. The distribution center also has products that carry UPC bar codes, placed there by the manufacturer. The Code 128 bar codes have the following format:

MMMMMPPPPD

Where:     M = Manufacturer ID  
           P = Part Number  
           D = Destination Code

The distribution center uses a host computer with dedicated control characters for manufacturer ID <CTRL M>, part number <CTRL P>, and destination code <CTRL D>. At this center the UPC data is treated as a manufacturer ID code.

The center programs the following rules:

- When scanning data of code type Code 128, send the next 5 characters, send the manufacturer ID key <CTRL M>, send the next 5 characters, send the part number key <CTRL P>, send the next 2 characters, send the destination code key <CTRL D>.
- When scanning data of code type UPC/EAN, send all data, send the manufacturer ID key <CTRL M>.

To enter these rules, see the following section.

## Rule 1: The Code 128 Scanning Rule

Step	Scan Bar Code	On Page	Beep Indication
1	Begin New Rule	<a href="#">15-8</a>	High High
2	Code 128	<a href="#">15-11</a>	High High
3	Send next 5 characters	<a href="#">15-28</a>	High High
4	Send <CTRL M>	<a href="#">15-48</a>	High High
5	Send next 5 characters	<a href="#">15-28</a>	High High
6	Send <CTRL P>	<a href="#">15-48</a>	High High
7	Send next 2 characters	<a href="#">15-27</a>	High High
8	Send <CTRL D>	<a href="#">15-47</a>	High High
9	Save Rule	<a href="#">15-8</a>	High Low High Low

## Rule 2: The UPC Scanning Rule

Step	Scan Bar Code	On Page	Beep Indication
1	Begin New Rule	<a href="#">15-8</a>	High High
2	UPC/EAN	<a href="#">15-12</a>	High High
3	Send all remaining data	<a href="#">15-27</a>	High High
4	Send <CTRL M>	<a href="#">15-48</a>	High High
5	Save Rule	<a href="#">15-8</a>	High Low High Low

To correct any errors made while entering this rule, scan [Quit Entering Rules on page 15-9](#), or after saving the rule, scan [Erase Previously Saved Rule on page 15-9](#).

---

## Alternate Rule Sets

You can group ADF rules into one of four alternate sets to turn on and off when needed. This is useful to format the same message in different ways. For example, a Code 128 bar code contains the following information:

Class (2 digits), Stock Number (8) digits, Price (5 digits)

This bar code might look like this:

245671243701500

where:

Class = 24

Stock Number = 56712437

Price = 01500

Ordinarily, data is sent as follows:

24 (class key)

56712437 (stock key)

01500 (enter key)

But, when there is a sale, send only the following:

24 (class key)

56712437 (stock key)

and the cashier enters the price manually.

To implement this, first enter an ADF rule that applies to the normal situation, such as:

Scan Rule Belongs to Set 1. When scanning a bar code of length 15, send the next 2 characters, send the class key, send the next 8 characters, send the stock key, send the data that remains, send the Enter key.

The “sale” rule may look like this:

Scan Rule Belongs to Set 2. When scanning a bar code of length 15, send the next 2 characters, send the class key, send the next 8 characters, send the stock key.

To switch between the two sets of rules, program a “switching rule” to specify what type of bar code to scan to switch between rule sets. For example, in the case of the “sale” rule above, the rule programmer wants the cashier to scan the bar code “M” before a sale. To do this, enter the rule as follows:

When scanning a bar code of length 1 that begins with “M”, select rule set number 1.

Program another rule to switch back:

When scanning a bar code of length 1 that begins with “N”, turn off rule set number 1.

Or include the switching back to normal rules in the “sale” rule:

When scanning a bar code of length 15, send the next 2 characters, send the class key, send the next 8 characters, send the stock key, turn off rule set 1.

For optimal results, scan the [Disable All Rule Sets on page 15-10](#) after programming a rule belonging to an alternate rule set.

In addition to enabling and disabling rule sets within the rules, enable or disable them by scanning the appropriate bar codes on [page 15-10](#).

---

## Rules Hierarchy (in Bar Codes)

When programming rules, be sure to program the most general rule first, as rules are stored at the “top” of a rules list in a buffer as they are entered. For example, if you create three rules, the list is configured as follows:

Third Rule  
Second Rule  
First Rule

After scanning data, the rules hierarchy checks the rules list from top to bottom to determine if the criteria matches (and therefore, whether to apply the actions). Actions modify the data format specified by the first matching set of criteria it finds, then disregard subsequent rules. For this reason, be sure to program the most general rule first.

For example, if the THIRD rule states:

When scanning a bar code of any length, send all data, then send the ENTER key.

and the SECOND rule states:

When scanning a Code 128 bar code of length 12, send the first four characters, then send the ENTER key, then send all remaining data.

and you scan a Code 128 bar code of length 12, the THIRD rule applies and the SECOND rule does not function.

Note standard data editing functions (scan options) are considered ADF rules, and the previous hierarchy applies to them. Scan options include prefix/suffix programming in the parameter [Scan Data Transmission Format on page 14-5](#). These rules reside in the same “rule list” as ADF rules, so the order you create them is also important.

---

## Default Rules

Every scanner has a default rule to send all scan data. Scanners with custom software may have one or more default rules burned in. The rules hierarchy checks user programmable rules first, then the default rules. To disable default rules enter the following general rule in the user programmable buffer:

When receiving scan data, send all data.

Since this rule always applies, ADF never applies the default rules.

---

## Special Considerations for Multipoint Networks

ADF rules scanned by an individual scanner are NOT broadcast to other scanners in the piconet, as are other parameters; however, ADF rules that 123Scan generates ARE broadcast to all scanners in the piconet. 123Scan rules transmitted from the base are stored at the BEGINNING of the ADF rule buffer, regardless of the presence of existing rules, while rules scanned by the scanner are appended to the existing buffer. For this reason, transmit rules to be shared by all scanners from 123Scan FIRST. Then, scan rules to customize an individual scanner.

## ADF Bar Codes

Table 15-1 lists the bar codes available through ADF.

**Table 15-1** ADF Bar Codes

Parameter	Page Number
<i>Special Commands</i>	15-8
<i>Pause Duration</i>	15-8
<i>Begin New Rule</i>	15-8
<i>Save Rule</i>	15-8
<i>Erase</i>	15-9
<i>Quit Entering Rules</i>	15-9
<i>Disable Rule Set</i>	15-10
<i>Criteria</i>	15-11
<i>Code Types</i>	15-11
<i>Code Lengths</i>	15-18
<i>1 Character - 6 Characters</i>	15-18
<i>7 Characters - 13 Characters</i>	15-19
<i>14 Characters - 20 Characters</i>	15-20
<i>21 Characters - 27 Characters</i>	15-21
<i>28 Characters - 30 Characters</i>	15-22
<i>Specific String at Start</i>	15-23
<i>Specific String, Any Location</i>	15-23
<i>Any Message OK</i>	15-23
<i>Numeric Keypad</i>	15-24
<i>Rule Belongs To Set</i>	15-26
<i>Actions</i>	15-27
<i>Send Data</i>	15-27
<i>Send Data Up To Character</i>	15-27
<i>Send Next Character</i>	15-27
<i>Send All Data That Remains</i>	15-27
<i>Send Next 2 Characters - Send Next 20 Characters</i>	15-27
<i>Move Cursor</i>	15-31



**Table 15-1** ADF Bar Codes (Continued)

Parameter	Page Number
<i>Send Pause</i>	15-31
<i>Skip Ahead</i>	15-32
<i>Skip Back</i>	15-33
<i>Send Preset Value</i>	15-35
<i>Remove All Spaces</i>	15-36
<i>Crunch All Spaces</i>	15-36
<i>Stop Space Removal</i>	15-36
<i>Remove Leading Zeros</i>	15-36
<i>Stop Zero Removal</i>	15-36
<i>Pad Data with Spaces</i>	15-37
<i>Pad Data with Zeros</i>	15-41
<i>Beeps</i>	15-46
<i>Send Keystroke (Control Characters and Keyboard Characters)</i>	15-46
<i>Keyboard Characters</i>	15-51
<i>Send ALT Characters</i>	15-65
<i>Send Keypad Characters</i>	15-70
<i>Send Function Key</i>	15-75
<i>Send F1 Key - Send F24 Key</i>	15-75
<i>Send PF1 Key - Send PF30 Key</i>	15-78
<i>Send Right Control Key</i>	15-82
<i>Send Graphic User Interface (GUI) Characters</i>	15-83
<i>Send GUI 0 - Send GUI 9</i>	15-83
<i>Send GUI A - Send GUI Z</i>	15-84
<i>Turn On Rule Sets</i>	15-88
<i>Alphanumeric Keyboard</i>	15-90
<i>Space - ' </i>	15-90
<i>0 - 9</i>	15-94
<i>A - Z</i>	15-95
<i>Cancel</i>	15-99

**Table 15-1** ADF Bar Codes (Continued)

Parameter	Page Number
<i>End of Message</i>	15-99
<i>a - z</i>	15-99
<i>{ - ~</i>	15-103

---

## Special Commands

### Pause Duration

This parameter, along with [Send Pause on page 15-31](#), inserts a pause in the data transmission. To set pauses scan a two-digit number (i.e., two bar codes) representing a 0.1 second interval in the range of 0.1 to 9.9. For example, scan bar codes **0** and **1** to insert a 0.1 second pause; **0** and **5** to insert a 0.5 second delay. The default is 1 second. See [Appendix D, Numeric Bar Codes](#). To correct an error or change a selection, scan [Cancel on page D-3](#).



**Pause Duration**

### Begin New Rule

Scan this bar code to start entering a new rule.



**Begin New Rule**

### Save Rule

Scan this bar code to save the rule.



**Save Rule**

## Erase

Use these bar codes to erase criteria, actions, or rules.



**Erase Criteria And Start Again**



**Erase Actions And Start Again**



**Erase Previously Saved Rule**



**Erase All Rules**

## Quit Entering Rules

Scan this bar code to quit entering rules.



**Quit Entering Rules**

## Disable Rule Set

Use these bar codes to disable rule sets.



**Disable Rule Set 1**



**Disable Rule Set 2**



**Disable Rule Set 3**



**Disable Rule Set 4**



**Disable All Rule Sets**

---

## Criteria

### Code Types

Select any number of code types to be affected by the rule. Scan all selected code types in succession, prior to selecting other criteria. *To select all code types, do not scan any code type.*



Code 39



Codabar



GS1 DataBar-14



GS1 DataBar Limited



GS1 DataBar Expanded



Code 128



D 2 OF 5

### Code Types (continued)



IATA 2 OF 5



I 2 OF 5



Code 93



UPC-A



UPC-E



EAN-8



EAN-13



ISSN

### Code Types (continued)



**MSI**



**GS1-128**



**UPC-E1**



**Bookland EAN**



**Trioptic Code 39**



**Code 11**



**Code 32**

## Code Types (continued)



**ISBT 128**



**Coupon Code**



**Chinese 2 of 5**



**Matrix 2 of 5**



**US Postnet**



**US Planet**



### Code Types (continued)



UK Postal



Japan Postal



Australian Postal



Netherlands KIX Code



USPS 4CB/One Code/Intelligent Mail



UPU FICS Postal



PDF417

## Code Types (continued)



**MicroPDF**



**Macro PDF**



**Macro MicroPDF**



**MaxiCode**



**Data Matrix**



**QR Code**



**MicroQR**

**Code Types (continued)****TLC 39****UPC/EAN Composites****GS1 DataBar and GS1-128 Composites****Aztec****Aztec Rune**

**NOTE** When selecting composite bar codes, enable AIM IDs if parsing UPC or EAN composite data, or data from an application that uses symbol separators.

## Code Lengths

Scan these bar codes to define the number of characters the selected code types must contain. Select one length per rule only. *Do not select any code length to select code types of any length.*



**1 Character**



**2 Characters**



**3 Characters**



**4 Characters**



**5 Characters**



**6 Characters**

### Code Lengths (continued)



7 Characters



8 Characters



9 Characters



10 Characters



11 Characters



12 Characters



13 Characters

### Code Lengths (continued)



14 Characters



15 Characters



16 Characters



17 Characters



18 Characters



19 Characters



20 Characters

### Code Lengths (continued)



21 Characters



22 Characters



23 Characters



24 Characters



25 Characters



26 Characters



27 Characters

### Code Lengths (continued)



**28 Characters**



**29 Characters**



**30 Characters**



## Message Containing a Specific Data String

Use this feature to select whether formatting affects data that begins with a specific character or data string, or contains a specific character or data string.

There are four features:

- Specific String at Start
- Specific String, Any Location
- Any Message OK
- Rule Belongs to Set.

### Specific String at Start

To set a specific string at start:

1. Scan the **Specific String At Start** bar code.
2. Scan bar codes representing the desired character string (up to 8 characters) using the [Alphanumeric Keyboard on page 15-90](#).
3. Scan [End of Message on page 15-99](#).



**Specific String At Start**

### Specific String, Any Location

To set a specific string, any location:

1. Scan the **Specific String Any Location** bar code.
2. Scan a two-digit number representing the *position* (use a leading zero if necessary) using the [Numeric Keypad on page 15-24](#).
3. Scan bar codes representing the desired character string (up to 8 characters) using the [Alphanumeric Keyboard on page 15-90](#).
4. Scan [End of Message on page 15-99](#).



**Specific String Any Location**

### Any Message OK

Do not scan any bar code to format all selected code types, regardless of information contained.

### Numeric Keypad

Do not confuse bar codes on this page with those on the alphanumeric keyboard.



0



1



2



3



4



5



6

**Numeric Keypad (continued)**



7



8



9



Cancel

### Rule Belongs To Set

Scan a bar code to select the set to which a rule belongs. There are four possible rule sets. See [Alternate Rule Sets on page 15-3](#) for more information about rule sets.



**Rule Belongs To Set 1**



**Rule Belongs To Set 2**



**Rule Belongs To Set 3**



**Rule Belongs To Set 4**

---

## Actions

Select how to format the data for transmission.

### Send Data

Send all data that follows, send all data up to a specific character selected from the [Alphanumeric Keyboard on page 15-90](#), or send the next *X* characters. Note that only bar codes for **Send Next 1 to 20** appear here, and can be scanned multiple times to send values greater than 20. For instance, to send the next 28 characters, scan **Send Next 20 Characters**, then **Send Next 8 Characters**.



Send Data Up To Character



Send All Data That Remains



Send Next Character



Send Next 2 Characters



Send Next 3 Characters



Send Next 4 Characters

## Send Data (continued)



**Send Next 5 Characters**



**Send Next 6 Characters**



**Send Next 7 Characters**



**Send Next 8 Characters**



**Send Next 9 Characters**



**Send Next 10 Characters**



**Send Next 11 Characters**

## Send Data (continued)



**Send Next 12 Characters**



**Send Next 13 Characters**



**Send Next 14 Characters**



**Send Next 15 Characters**



**Send Next 16 Characters**



**Send Next 17 Characters**



**Send Next 18 Characters**

## Send Data (continued)



**Send Next 19 Characters**



**Send Next 20 Characters**



## Setup Field(s)

### Move Cursor

Select one of the following Move Cursor options:

- Scan the **Move Cursor To a Character** bar code, then enter a character by scanning a bar code from the [Alphanumeric Keyboard on page 15-90](#), to move the cursor to the position after the matching character. If the character is not there, the rule fails and ADF tries the next rule.
- Scan the **Move Cursor to Start** bar code to move the cursor to the beginning of the data.
- Scan the **Move Cursor Past Character** bar code, then enter a character by scanning a bar code from the [Alphanumeric Keyboard on page 15-90](#), to move the cursor past all sequential occurrences of this character. For example, if the selected character is 'A', then the cursor moves past 'A', 'AA', 'AAA', etc. If the character is not there, the cursor does not move (i.e., this has no effect).



**Move Cursor To Character**



**Move Cursor To Start**



**Move Cursor Past Character**

### Send Pause

Scan the bar code below to insert a pause in the transmission of data. To set the length of this pause, see [Pause Duration on page 15-8](#).



**Send Pause**

## Skip Ahead

Use the following bar codes to move the cursor ahead characters.



**Skip Ahead 1 Character**



**Skip Ahead 2 Characters**



**Skip Ahead 3 Characters**



**Skip Ahead 4 Characters**



**Skip Ahead 5 Characters**



**Skip Ahead 6 Characters**



**Skip Ahead 7 Characters**

**Skip Ahead (continued)****Skip Ahead 8 Characters****Skip Ahead 9 Characters****Skip Ahead 10 Characters****Skip Back**

Use the following bar codes to move the cursor back characters.

**Skip Back 1 Character****Skip Back 2 Characters****Skip Back 3 Characters**

**Skip Back (continued)**



**Skip Back 4 Characters**



**Skip Back 5 Characters**



**Skip Back 6 Characters**



**Skip Back 7 Characters**



**Skip Back 8 Characters**



**Skip Back 9 Characters**



**Skip Back 10 Characters**

**Send Preset Value**

Use these bar codes to send preset values. To set these values, see [Prefix/Suffix Values on page 14-4](#). For conversion information, see the ASCII Character Set tables in the appropriate host chapter.



**Send Prefix (Value 2)**

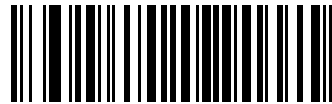

**Send Suffix (Value 1)**

## Modify Data

These options modify data as described and apply to all send commands that follow it within a rule. For example, programming *pad zeros to length 6, send next 3 characters, stop padding, send next 5 characters*, adds three zeros to the first send, and the next send is unaffected by the padding. These options do not apply to the **Send Keystroke** or **Send Preset Value** options.

### Remove All Spaces

To remove all spaces in the send commands that follow, scan this bar code.



**Remove All Spaces**

### Crunch All Spaces

To leave one space between words, scan this bar code. This also removes all leading and trailing spaces.



**Crunch All Spaces**

### Stop Space Removal

Scan this bar code to disable space removal.



**Stop Space Removal**

### Remove Leading Zeros

Scan this bar code to remove all leading zeros.



**Remove Leading Zeros**

### Stop Zero Removal

Scan this bar code to disable the removal of zeros.



**Stop Zero Removal**

## Pad Data with Spaces

To pad data to the left, scan the bar code containing the desired number of spaces. Send commands activate this parameter.



**Pad Spaces To Length 1**



**Pad Spaces To Length 2**



**Pad Spaces To Length 3**



**Pad Spaces To Length 4**



**Pad Spaces To Length 5**



**Pad Spaces To Length 6**



**Pad Spaces To Length 7**

### Pad Data with Spaces (continued)



Pad Spaces To Length 8



Pad Spaces To Length 9



Pad Spaces To Length 10



Pad Spaces To Length 11



Pad Spaces To Length 12



Pad Spaces To Length 13



Pad Spaces To Length 14



### Pad Data with Spaces (continued)



Pad Spaces To Length 15



Pad Spaces To Length 16



Pad Spaces To Length 17



Pad Spaces To Length 18



Pad Spaces To Length 19



Pad Spaces To Length 20



Pad Spaces To Length 21

### Pad Data with Spaces (continued)



Pad Spaces To Length 22



Pad Spaces To Length 23



Pad Spaces To Length 24



Pad Spaces To Length 25



Pad Spaces To Length 26



Pad Spaces To Length 27



Pad Spaces To Length 28

## Pad Data with Spaces (continued)



Pad Spaces To Length 29



Pad Spaces To Length 30



Stop Pad Spaces

## Pad Data with Zeros

To pad data to the left, scan the bar code containing the desired number of zeros. Send commands activate this parameter.



Pad Zeros To Length 1



Pad Zeros To Length 2



Pad Zeros To Length 3

### Pad Data with Zeros (continued)



Pad Zeros To Length 4



Pad Zeros To Length 5



Pad Zeros To Length 6



Pad Zeros To Length 7



Pad Zeros To Length 8



Pad Zeros To Length 9



Pad Zeros To Length 10

### Pad Data with Zeros (continued)



Pad Zeros To Length 11



Pad Zeros To Length 12



Pad Zeros To Length 13



Pad Zeros To Length 14



Pad Zeros To Length 15



Pad Zeros To Length 16



Pad Zeros To Length 17

### Pad Data with Zeros (continued)



Pad Zeros To Length 18



Pad Zeros To Length 19



Pad Zeros To Length 20



Pad Zeros To Length 21



Pad Zeros To Length 22



Pad Zeros To Length 23



Pad Zeros To Length 24

### Pad Data with Zeros (continued)



Pad Zeros To Length 25



Pad Zeros To Length 26



Pad Zeros To Length 27



Pad Zeros To Length 28



Pad Zeros To Length 29



Pad Zeros To Length 30



Stop Pad Zeros

## Beeps

Select a beep sequence for each ADF rule.



**Beep Once**



**Beep Twice**



**Beep Three Times**

## Send Keystroke (Control Characters and Keyboard Characters)

### Control Characters

Scan a **Send** bar code to specify the keystroke to send.



**Send Control 2**



**Send Control A**



**Send Control B**



**Control Characters (continued)**



**Send Control C**



**Send Control D**



**Send Control E**



**Send Control F**



**Send Control G**



**Send Control H**



**Send Control I**

**Control Characters (continued)**



**Send Control J**



**Send Control K**



**Send Control L**



**Send Control M**



**Send Control N**



**Send Control O**



**Send Control P**

**Control Characters (continued)**



**Send Control Q**



**Send Control R**



**Send Control S**



**Send Control T**



**Send Control U**



**Send Control V**



**Send Control W**

**Control Characters (continued)**



**Send Control X**



**Send Control Y**



**Send Control Z**



**Send Control [**



**Send Control \**



**Send Control ]**

**Control Characters (continued)****Send Control 6****Send Control -****Keyboard Characters**

Scan a **Send** bar code to specify the keyboard characters to send.

**Send Space****Send !**

**Keyboard Characters (continued)**



**Send \$**



**Send %**



**Send &**



**Send '**



**Send (/**



**Send )**



**Send \***

**Keyboard Characters (continued)**



**Send +**



**Send ,**



**Send -**



**Send .**



**Send /**



**Send 0**



**Send 1**

**Keyboard Characters (continued)**



**Send 2**



**Send 3**



**Send 4**



**Send 5**



**Send 6**



**Send 7**



**Send 8**



**Keyboard Characters (continued)**



**Send 9**



**Send :**



**Send ;**



**Send <**



**Send =**



**Send >**



**Send ?**

**Keyboard Characters (continued)**



**Send @**



**Send A**



**Send B**



**Send C**



**Send D**



**Send E**



**Send F**

**Keyboard Characters (continued)**



**Send G**



**Send H**



**Send I**



**Send J**



**Send K**



**Send L**



**Send M**

**Keyboard Characters (continued)**



**Send N**



**Send O**



**Send P**



**Send Q**



**Send R**



**Send S**



**Send T**

**Keyboard Characters (continued)**



**Send U**



**Send V**



**Send W**



**Send X**



**Send Y**



**Send Z**



**Send [**

**Keyboard Characters (continued)**



**Send \**



**Send ]**



**Send ^**



**Send \_**



**Send `**



**Send a**



**Send b**

**Keyboard Characters (continued)**



**Send c**



**Send d**



**Send e**



**Send f**



**Send g**



**Send h**



**Send i**

**Keyboard Characters (continued)**



**Send j**



**Send k**



**Send l**



**Send m**



**Send n**



**Send o**



**Send p**



**Keyboard Characters (continued)**



**Send q**



**Send r**



**Send s**



**Send t**



**Send u**



**Send v**



**Send w**

**Keyboard Characters (continued)**



**Send x**



**Send y**



**Send z**



**Send {**



**Send |**



**Send }**



**Send ~**

### Send ALT Characters



Send Alt 2



Send Alt A



Send Alt B



Send Alt C



Send Alt D



Send Alt E



Send Alt F

**Send ALT Characters (continued)**



**Send Alt G**



**Send Alt H**



**Send Alt I**



**Send Alt J**



**Send Alt K**



**Send Alt L**



**Send Alt M**

**Send ALT Characters (continued)**



**Send Alt N**



**Send Alt O**



**Send Alt P**



**Send Alt Q**



**Send Alt R**



**Send Alt S**



**Send Alt T**

**Send ALT Characters (continued)**



**Send Alt U**



**Send Alt V**



**Send Alt W**



**Send Alt X**



**Send Alt Y**



**Send Alt Z**



**Send Alt [**

**Send ALT Characters (continued)**



**Send Alt \**



**Send Alt ]**

### Send Keypad Characters



Send Keypad \*



Send Keypad +



Send Keypad -



Send Keypad .



Send Keypad /



Send Keypad 0



Send Keypad 1



**Send Keypad Characters (continued)**



**Send Keypad 2**



**Send Keypad 3**



**Send Keypad 4**



**Send Keypad 5**



**Send Keypad 6**



**Send Keypad 7**



**Send Keypad 8**

**Send Keypad Characters (continued)**



**Send Keypad 9**



**Send Keypad Enter**



**Send Keypad Numlock**



**Send Break Key**



**Send Delete Key**



**Send Page Up Key**



**Send End Key**

**Send Keypad Characters (continued)**



**Send Page Down Key**



**Send Pause Key**



**Send Scroll Lock Key**



**Send Backspace Key**



**Send Tab Key**



**Send Print Screen Key**



**Send Insert Key**

**Send Keypad Characters (continued)**



**Send Home Key**



**Send Enter Key**



**Send Escape Key**



**Send Up Arrow Key**



**Send Down Arrow Key**



**Send Left Arrow Key**



**Send Right Arrow Key**

### Send Function Key



Send F1 Key



Send F2 Key



Send F3 Key



Send F4 Key



Send F5 Key



Send F6 Key



Send F7 Key

**Send Function Key (continued)**



**Send F8 Key**



**Send F9 Key**



**Send F10 Key**



**Send F11 Key**



**Send F12 Key**



**Send F13 Key**



**Send F14 Key**

**Send Function Key (continued)**



**Send F15 Key**



**Send F16 Key**



**Send F17 Key**



**Send F18 Key**



**Send F19 Key**



**Send F20 Key**



**Send F21 Key**

**Send Function Key (continued)**



**Send F22 Key**



**Send F23 Key**



**Send F24 Key**



**Send PF1 Key**



**Send PF2 Key**



**Send PF3 Key**



**Send PF4 Key**



**Send Function Key (continued)**



**Send PF5 Key**



**Send PF6 Key**



**Send PF7 Key**



**Send PF8 Key**



**Send PF9 Key**



**Send PF10 Key**



**Send PF11 Key**

**Send Function Key (continued)**



**Send PF12 Key**



**Send PF13 Key**



**Send PF14 Key**



**Send PF15 Key**



**Send PF16 Key**



**Send PF17 Key**



**Send PF18 Key**

**Send Function Key (continued)**



**Send PF19 Key**



**Send PF20 Key**



**Send PF21 Key**



**Send PF22 Key**



**Send PF23 Key**



**Send PF24 Key**



**Send PF25 Key**

### Send Function Key (continued)



Send PF26 Key



Send PF27 Key



Send PF28 Key



Send PF29 Key



Send PF30 Key

### Send Right Control Key

Scan the **Send Right Control Key** bar code to send a tap (press and release) of the Right Control Key.

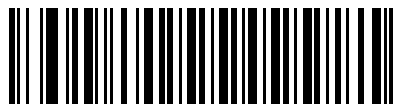

Send Right Control Key

## Send Graphic User Interface (GUI) Characters

These actions tap the specified key while holding the system-dependent GUI key. The definition of the GUI key depends on the attached system.



**Send GUI 0**

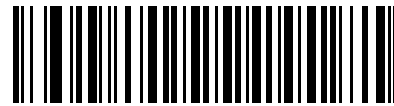

**Send GUI 1**

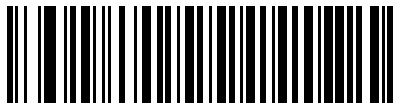

**Send GUI 2**

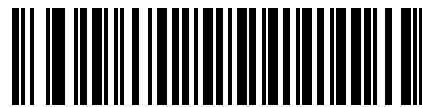

**Send GUI 3**

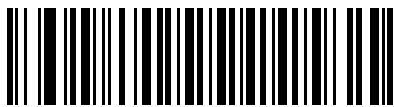

**Send GUI 4**

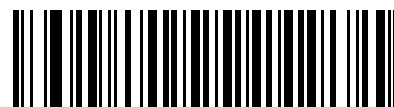

**Send GUI 5**

### Send Graphic User Interface (GUI) Characters (continued)



Send GUI 6



Send GUI 7

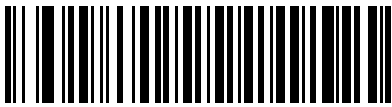

Send GUI 8



Send GUI 9

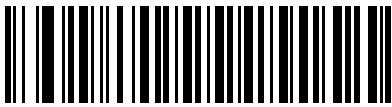

Send GUI A

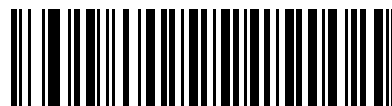

Send GUI B



Send GUI C

### Send Graphic User Interface (GUI) Characters (continued)



Send GUI D

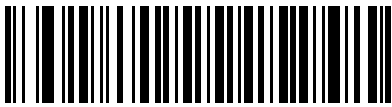

Send GUI E

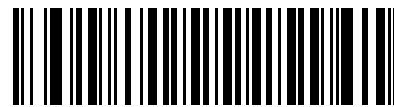

Send GUI F

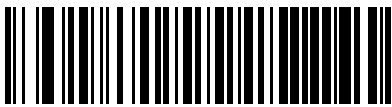

Send GUI G

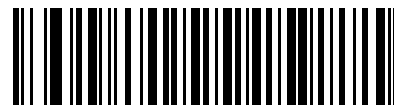

Send GUI H



Send GUI I

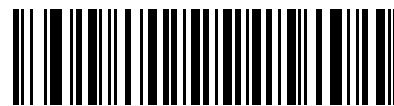

Send GUI J

### Send Graphic User Interface (GUI) Characters (continued)



Send GUI K

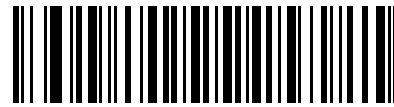

Send GUI L

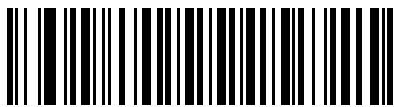

Send GUI M

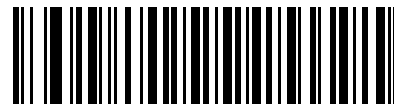

Send GUI N

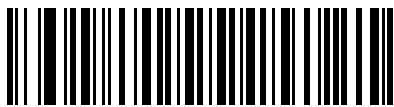

Send GUI O

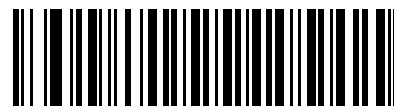

Send GUI P

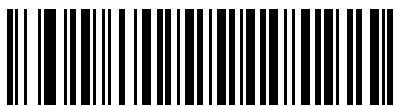

Send GUI Q



### Send Graphic User Interface (GUI) Characters (continued)



Send GUI R



Send GUI S

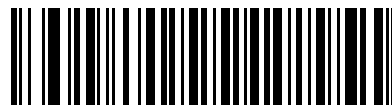

Send GUI T



Send GUI U

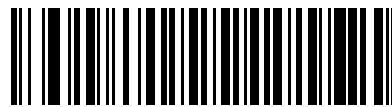

Send GUI V



Send GUI W

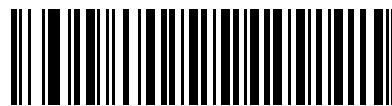

Send GUI X

## Send Graphic User Interface (GUI) Characters (continued)



Send GUI Y



Send GUI Z

## Turn On Rule Sets

Use these bar codes to turn rule sets on.



Turn On Rule Set 1



Turn On Rule Set 2



Turn On Rule Set 3



Turn On Rule Set 4

## Turn Off Rule Sets

Use these bar codes to turn rule sets off.



**Turn Off Rule Set 1**



**Turn Off Rule Set 2**



**Turn Off Rule Set 3**



**Turn Off Rule Set 4**

---

## Alphanumeric Keyboard



Space



#



\$



%



\*



+



-  
(Dash)

---

## Alphanumeric Keyboard (continued)



,



.



!



/



&



“



(



{

---

## Alphanumeric Keyboard (continued)



)



:



;



<



=



>



?

---

## Alphanumeric Keyboard (continued)



@



[



\



]



^



<sup>—</sup>  
(Underscore)



,

---

## Alphanumeric Keyboard (continued)

✓ **NOTE** Do not confuse the following numeric bar codes with those on the numeric keypad.



0



1



2



3



4



5



---

## Alphanumeric Keyboard (continued)



6



7



8



9



A



B



C

---

## Alphanumeric Keyboard (continued)



E



D



F



G



H



I



J

---

## Alphanumeric Keyboard (continued)



K



L



M



N



O



P



Q

---

## Alphanumeric Keyboard (continued)



S



R



T



U



V



W



X

---

## Alphanumeric Keyboard (continued)



Y



Z



Cancel



End of Message



a



b



c

---

## Alphanumeric Keyboard (continued)



e



d



f



g



h



i



j

---

## Alphanumeric Keyboard (continued)



k



l



m



n



o



p



q

---

## Alphanumeric Keyboard (continued)



s



r



t



u



v



w



x



---

## Alphanumeric Keyboard (continued)



y



z



{



|



}



~



# Appendix A Standard Default Parameters

**Table A-1** Standard Default Parameters Table

Parameter	Default	Page Number
<b>User Preferences</b>		
Set Default Parameter	All Defaults	4-3
Parameter Scanning	Enable	4-3
Beeper Tone	Medium	4-4
Beeper Volume	High	4-5
Power Mode	Reduced	4-5
Beep After Good Decode	Enable	4-6
Picklist Mode	Disabled Always	4-7
Decode Session Timeout	3.0 seconds	4-8
Fuzzy 1D Decoding	Enable	4-8
Decode Mirror Images	Never	4-9
<b>Radio Communications</b>		
Connection Maintenance Interval	15 minutes	4-10
Radio Output Power (Bluetooth)	Class 1	4-12
Parameter Broadcast	Enable	4-12
Single Point/Multipoint Operation	Single Point	4-13

<sup>1</sup>User selection is required to configure this interface and this is the most common selection.

**Table A-1** Standard Default Parameters Table (Continued)

Parameter	Default	Page Number
<b>Decoding Options</b>		
Focus Mode	Far Focus	5-3
Decoding Illumination	Enable	5-4
Decode Aiming Pattern	Enable	5-4
DPM Scanning	Enable	5-5
<b>Keyboard Wedge Host Parameters</b>		
Keyboard Wedge Host Type	IBM PC/AT& IBM PC Compatibles <sup>1</sup>	6-4
Keyboard Wedge Country Types (Country Codes)	North American	6-5
Ignore Unknown Characters	Enable	6-7
Keystroke Delay	0 msec (No Delay)	6-7
Intra-Keystroke Delay	Disable	6-8
Alternate Numeric Keypad Emulation	Disable	6-8
Caps Lock On	Disable	6-9
Caps Lock Override	Disable	6-9
Convert Wedge Data	Do Not Convert Wedge Data	6-10
Function Key Mapping	Disable	6-10
FN1 Substitution	Disable	6-11
Send Make and Break	Send Make and Break Scan Codes	6-11
<b>RS-232 Host Parameters</b>		
RS-232 Host Types	Standard RS-232 <sup>1</sup>	7-6
Baud Rate	9600	7-7
Parity	None	7-9
Check Receive Errors	Enable	7-10
Stop Bit Select	1 Stop Bit	7-10
Data Bits	8-Bit	7-11

<sup>1</sup>User selection is required to configure this interface and this is the most common selection.

**Table A-1** Standard Default Parameters Table (Continued)

Parameter	Default	Page Number
Hardware Handshaking	None	7-11
Software Handshaking	None	7-13
Host Serial Response Time-out	Minimum: 2 Sec	7-15
RTS Line State	Host: Low RTS	7-16
Beep on <BEL>	Disable	7-16
Intercharacter Delay	Minimum: 0 msec	7-17
Nixdorf Mode A/B and OPOS/JPOS Beep/LED Options	Normal Operation	7-18
Ignore Unknown Characters	Send Bar Code	7-19
<b>USB Host Parameters</b>		
USB Device Type	HID Keyboard Emulation	8-4
USB Country Keyboard Types (Country Codes)	North American	8-5
USB Keystroke Delay	No Delay (0 msec)	8-7
USB CAPS Lock Override	Disable	8-7
USB Ignore Unknown Characters	Enable	8-8
Emulate Keypad	Disable	8-8
USB Keyboard FN1 Substitution	Disable	8-9
Function Key Mapping	Disable	8-9
Simulated Caps Lock	Disable	8-10
Convert Case	No Case Conversion	8-10
<b>IBM 468X/469X Host Parameters</b>		
Port Address	None Selected	9-4
Convert Unknown to Code 39	Disable	9-5
<b>Wand Emulation Host Parameters</b>		
Wand Emulation Host Types	Symbol OmniLink Interface Controller <sup>1</sup>	10-4
Leading Margin	80 msec	10-5
Polarity	Bar High/Margin Low	10-6

<sup>1</sup>User selection is required to configure this interface and this is the most common selection.

**Table A-1** Standard Default Parameters Table (Continued)

Parameter	Default	Page Number
Ignore Unknown Characters	Enable	10-6
Convert All to Code 39	Disable	10-7
Convert Code 39 to Full ASCII	Disable	10-8
<b>Scanner Emulation Host Parameters</b>		
Beep Style	Beep on Successful Transmit	11-4
Parameter Pass-Through	Parameter Process and Pass Through	11-5
Convert Newer Code Types	Convert Newer Code Types	11-6
Module Width	20 $\mu$ s Module Width	11-7
Convert All Bar Codes to Code 39	Disable	11-7
Code 39 Full ASCII Conversion	Disable	11-8
Transmission Timeout	3 seconds	11-9
Ignore Unknown Characters	Send Bar Codes with Unknown Characters	11-10
Leading Margin	2 ms	11-11
Check for Decode LED	Check for Decode LED	11-12
<b>123Scan Configuration Tool</b>		
123Scan Configuration	None <sup>1</sup>	12-1
<b>UPC/EAN</b>		
UPC-A	Enable	13-7
UPC-E	Enable	13-7
UPC-E1	Disable	13-8
EAN-13	Enable	13-8
EAN-8	Enable	13-9
Bookland EAN	Disable	13-9
Decode UPC/EAN Supplementals (2 and 5 digits)	Ignore Supplementals	13-10

<sup>1</sup>User selection is required to configure this interface and this is the most common selection.

**Table A-1** Standard Default Parameters Table (Continued)

Parameter	Default	Page Number
User-Programmable Supplementals		<a href="#">13-13</a>
UPC/EAN Supplemental Redundancy	10	<a href="#">13-13</a>
Transmit UPC-A Check Digit	Enable	<a href="#">13-14</a>
Transmit UPC-E Check Digit	Enable	<a href="#">13-14</a>
Transmit UPC-E1 Check Digit	Enable	<a href="#">13-15</a>
UPC-A Preamble	System Character	<a href="#">13-16</a>
UPC-E Preamble	System Character	<a href="#">13-17</a>
UPC-E1 Preamble	System Character	<a href="#">13-18</a>
Convert UPC-E to A	Disable	<a href="#">13-19</a>
Convert UPC-E1 to A	Disable	<a href="#">13-19</a>
EAN-8 Extend	Disable	<a href="#">13-20</a>
Bookland ISBN Format	ISBN-10	<a href="#">13-21</a>
UCC Coupon Extended Code	Disable	<a href="#">13-22</a>
ISSN EAN	Disable	<a href="#">13-22</a>
<b>Code 128</b>		
Code 128	Enable	<a href="#">13-23</a>
Set Length(s) for Code 128	Any Length	<a href="#">13-23</a>
GS1-128 (formerly UCC/EAN-128)	Enable	<a href="#">13-25</a>
ISBT 128	Enable	<a href="#">13-25</a>
ISBT Concatenation	Disable	<a href="#">13-26</a>
Check ISBT Table	Enable	<a href="#">13-27</a>
ISBT Concatenation Redundancy	10	<a href="#">13-27</a>
<b>Code 39</b>		
Code 39	Enable	<a href="#">13-28</a>
Trioptic Code 39	Disable	<a href="#">13-28</a>
Convert Code 39 to Code 32	Disable	<a href="#">13-29</a>
Code 32 Prefix	Disable	<a href="#">13-29</a>
Set Length(s) for Code 39	2 to 55	<a href="#">13-30</a>

**<sup>1</sup>User selection is required to configure this interface and this is the most common selection.**

**Table A-1** Standard Default Parameters Table (Continued)

Parameter	Default	Page Number
Code 39 Check Digit Verification	Disable	<a href="#">13-32</a>
Transmit Code 39 Check Digit	Disable	<a href="#">13-32</a>
Code 39 Full ASCII Conversion	Disable	<a href="#">13-33</a>
Buffer Code 39	Disable	<a href="#">13-34</a>
<b>Code 93</b>		
Code 93	Disable	<a href="#">13-36</a>
Set Lengths for Code 93	4 to 55	<a href="#">13-36</a>
<b>Code 11</b>		
Code 11	Disable	<a href="#">13-38</a>
Set Lengths for Code 11	4 to 55	<a href="#">13-38</a>
Code 11 Check Digit Verification	Disable	<a href="#">13-40</a>
Transmit Code 11 Check Digits	Disable	<a href="#">13-41</a>
<b>Interleaved 2 of 5 (I 2 of 5)</b>		
Interleaved 2 of 5 (I 2 of 5)	Enable	<a href="#">13-42</a>
Set Lengths for Interleaved 2 of 5	14	<a href="#">13-42</a>
I 2 of 5 Check Digit Verification	Disable	<a href="#">13-44</a>
Transmit I 2 of 5 Check Digit	Disable	<a href="#">13-44</a>
Convert I 2 of 5 to EAN-13	Disable	<a href="#">13-45</a>
<b>Discrete 2 of 5 (D 2 of 5)</b>		
Discrete 2 of 5	Disable	<a href="#">13-46</a>
Set Lengths for D 2 of 5	12	<a href="#">13-46</a>
<b>Codabar (NW - 7)</b>		
Codabar	Disable	<a href="#">13-48</a>
Set Lengths for Codabar	5 to 55	<a href="#">13-48</a>
CLSI Editing	Disable	<a href="#">13-50</a>
NOTIS Editing	Disable	<a href="#">13-50</a>

<sup>1</sup>User selection is required to configure this interface and this is the most common selection.



**Table A-1** Standard Default Parameters Table (Continued)

Parameter	Default	Page Number
<b>MSI</b>		
MSI	Disable	13-51
Set Lengths for MSI	4 to 55	13-51
MSI Check Digits	One	13-53
Transmit MSI Check Digit(s)	Disable	13-53
MSI Check Digit Algorithm	Mod 10/Mod 10	13-54
<b>Chinese 2 of 5</b>		
Chinese 2 of 5	Disable	13-54
<b>Matrix 2 of 5</b>		
Matrix 2 of 5	Disable	13-55
Matrix 2 of 5 Lengths	1 Length - 14	13-56
Matrix 2 of 5 Redundancy	Disable	13-57
Matrix 2 of 5 Check Digit	Disable	13-57
Transmit Matrix 2 of 5 Check Digit	Disable	13-58
<b>Inverse 1D</b>	Regular	13-58
<b>Postal Codes</b>		
US Postnet	Enable	13-59
US Planet	Enable	13-59
Transmit US Postal Check Digit	Enable	13-60
UK Postal	Enable	13-60
Transmit UK Postal Check Digit	Enable	13-61
Japan Postal	Enable	13-61
Australian Postal	Enable	13-62
Netherlands KIX Code	Enable	13-62
USPS 4CB/One Code/Intelligent Mail	Disable	13-63
UPU FICS Postal	Disable	13-63

<sup>1</sup>User selection is required to configure this interface and this is the most common selection.

**Table A-1** Standard Default Parameters Table (Continued)

Parameter	Default	Page Number
<b>GS1 DataBar</b>		
GS1 DataBar-14	Enable	<a href="#">13-64</a>
GS1 DataBar Limited	Enable	<a href="#">13-64</a>
GS1 DataBar Expanded	Enable	<a href="#">13-65</a>
Convert GS1 DataBar to UPC/EAN	Disable	<a href="#">13-65</a>
<b>Composite</b>		
Composite CC-C	Disable	<a href="#">13-66</a>
Composite CC-A/B	Disable	<a href="#">13-66</a>
Composite TLC-39	Disable	<a href="#">13-67</a>
UPC Composite Mode	Always Linked	<a href="#">13-67</a>
GS1-128 Emulation Mode for UCC/EAN Composite Codes	Disable	<a href="#">13-68</a>
<b>2D Symbologies</b>		
PDF417	Enable	<a href="#">13-69</a>
MicroPDF417	Disable	<a href="#">13-69</a>
Code 128 Emulation	Disable	<a href="#">13-70</a>
Data Matrix	Enable	<a href="#">13-71</a>
Data Matrix Inverse	Regular	<a href="#">13-71</a>
Maxicode	Enable	<a href="#">13-72</a>
QR Code	Enable	<a href="#">13-73</a>
QR Inverse	Regular	<a href="#">13-73</a>
MicroQR	Enable	<a href="#">13-74</a>
Aztec	Enable	<a href="#">13-75</a>
Aztec Inverse	Enable	<a href="#">13-75</a>
<b>Symbology - Specific Security Levels</b>		
Redundancy Level	1	<a href="#">13-76</a>
Security Levels	0	<a href="#">13-78</a>
Intercharacter Gap Size	Normal	<a href="#">13-80</a>

**<sup>1</sup>User selection is required to configure this interface and this is the most common selection.**

**Table A-1** Standard Default Parameters Table (Continued)

Parameter	Default	Page Number
<b>Macro PDF</b>		
Flush Macro PDF Buffer		<a href="#">13-81</a>
Abort Macro PDF Entry		<a href="#">13-81</a>
<b>Miscellaneous Scanner Options</b>		
Transmit Code ID Character	None	<a href="#">14-3</a>
Prefix Value	7013 <CR><LF>	<a href="#">14-4</a>
Suffix 1 Value Suffix 2 Value	7013 <CR><LF>	<a href="#">14-4</a>
Scan Data Transmission Format	Data As Is	<a href="#">14-5</a>
FN1 Substitution Values	Set FN1 Substitution Value	<a href="#">14-6</a>
Transmit "No Read" Message	Disable No Read	<a href="#">14-7</a>
Report Version		<a href="#">14-7</a>

**<sup>1</sup>User selection is required to configure this interface and this is the most common selection.**



# Appendix B Programming Reference

## Symbol Code Identifiers

**Table B-1** *Symbol Code Characters*

Code Character	Code Type
A	UPC-A, UPC-E, UPC-E1, EAN-8, EAN-13
B	Code 39, Code 32
C	Codabar
D	Code 128, ISBT 128, ISBT 128 Concatenated
E	Code 93
F	Interleaved 2 of 5
G	Discrete 2 of 5, or Discrete 2 of 5 IATA
H	Code 11
J	MSI
K	GS1-128
L	Bookland EAN
M	Trioptic Code 39
N	Coupon Code
R	GS1 DataBar Family
S	Matrix 2 of 5
T	UCC Composite, TLC 39
U	Chinese 2 of 5

**Table B-1** *Symbol Code Characters (Continued)*

<b>Code Character</b>	<b>Code Type</b>
X	ISSN EAN, PDF417, Macro PDF417, Micro PDF417,
z	Aztec, Aztec Rune
P00	Data Matrix
P01	QR Code, MicroQR
P02	Maxicode
P03	US Postnet
P04	US Planet
P05	Japan Postal
P06	UK Postal
P08	Netherlands KIX Code
P09	Australian Postal
P0A	USPS 4CB/One Code/Intelligent Mail
P0B	UPU FICS Postal

## AIM Code Identifiers

Each AIM Code Identifier contains the three-character string **Jcm** where:

- J = Flag Character (ASCII 93)
- c = Code Character (see [Table B-2](#))
- m = Modifier Character (see [Table B-3](#))

**Table B-2** *Aim Code Characters*

Code Character	Code Type
A	Code 39, Code 39 Full ASCII, Code 32
C	Code 128, ISBT 128, ISBT 128 Concatenated, GS1-128, Coupon (Code 128 portion)
d	Data Matrix
E	UPC/EAN, Coupon (UPC portion)
e	GS1 DataBar Family
F	Codabar
G	Code 93
H	Code 11
I	Interleaved 2 of 5
L	PDF417, Macro PDF417, Micro PDF417
L2	TLC 39
M	MSI
Q	QR Code, MicroQR
S	Discrete 2 of 5, IATA 2 of 5
U	Maxicode
z	Aztec, Aztec Rune
X	Bookland EAN, ISSN EAN, Trioptic Code 39, Chinese 2 of 5, Matrix 2 of 5, US Postnet, US Planet, UK Postal, Japan Postal, Australian Postal, Netherlands KIX Code, USPS 4CB/One Code/ Intelligent Mail, UPU FICS Postal

The modifier character is the sum of the applicable option values based on [Table B-3](#).

**Table B-3** *Modifier Characters*

Code Type	Option Value	Option
Code 39	0	No check character or Full ASCII processing.
	1	Reader has checked one check character.
	3	Reader has checked and stripped check character.
	4	Reader has performed Full ASCII character conversion.
	5	Reader has performed Full ASCII character conversion and checked one check character.
	7	Reader has performed Full ASCII character conversion and checked and stripped check character.
Example: A Full ASCII bar code with check character W, <b>A+I+MI+DW</b> , is transmitted as <b>JA7AIMID</b> where 7 = (3+4).		
Trioptic Code 39	0	No option specified at this time. Always transmit 0.
	Example: A Trioptic bar code 412356 is transmitted as <b>JX0412356</b>	
Code 128	0	Standard data packet, no Function code 1 in first symbol position.
	1	Function code 1 in first symbol character position.
	2	Function code 1 in second symbol character position.
Example: A Code (EAN) 128 bar code with Function 1 character <sup>FNC1</sup> in the first position, AIMID is transmitted as <b>JC1AIMID</b>		
I 2 of 5	0	No check digit processing.
	1	Reader has validated check digit.
	3	Reader has validated and stripped check digit.
Example: An I 2 of 5 bar code without check digit, 4123, is transmitted as <b>JI04123</b>		
Codabar	0	No check digit processing.
	1	Reader has checked check digit.
	3	Reader has stripped check digit before transmission.
Example: A Codabar bar code without check digit, 4123, is transmitted as <b>JF04123</b>		
Code 93	0	No options specified at this time. Always transmit 0.
	Example: A Code 93 bar code 012345678905 is transmitted as <b>JG0012345678905</b>	



**Table B-3** *Modifier Characters (Continued)*

Code Type	Option Value	Option
MSI	0	Check digits are sent.
	1	No check digit is sent.
	Example: An MSI bar code 4123, with a single check digit checked, is transmitted as <b>JM14123</b>	
D 2 of 5	0	No options specified at this time. Always transmit 0.
	Example: A D 2 of 5 bar code 4123, is transmitted as <b>JS04123</b>	
UPC/EAN	0	Standard packet in full EAN country code format, which is 13 digits for UPC-A, UPC-E, and EAN-13 (not including supplemental data).
	1	Two-digit supplement data only.
	2	Five-digit supplement data only.
	3	Combined data packet comprising 13 digits from a UPC-A, UPC-E, or EAN-13 symbol and 2 or 5 digits from a supplemental symbol.
	4	EAN-8 data packet.
	Example: A UPC-A bar code 012345678905 is transmitted as <b>JE00012345678905</b>	
Bookland EAN	0	No options specified at this time. Always transmit 0.
	Example: A Bookland EAN bar code 123456789X is transmitted as <b>JX0123456789X</b>	
ISSN EAN	0	No options specified at this time. Always transmit 0.
	Example: An ISSN EAN bar code 123456789X is transmitted as <b>JX0123456789X</b>	
Code 11	0	Single check digit
	1	Two check digits
	3	Check characters validated but not transmitted.
GS1 DataBar Family		No option specified at this time. Always transmit 0. GS1 DataBar-14 and GS1 DataBar Limited transmit with an Application Identifier "01". Note: In GS1-128 emulation mode, GS1 DataBar is transmitted using Code 128 rules (i.e., J C1).
	Example: A GS1 DataBar-14 bar code 0110012345678902 is transmitted as <b>Je00110012345678902</b> .	

**Table B-3** *Modifier Characters (Continued)*

Code Type	Option Value	Option
EAN.UCC Composites (GS1 DataBar, GS1-128, 2D portion of UPC composite)		Native mode transmission. Note: UPC portion of composite is transmitted using UPC rules.
	0	Standard data packet.
	1	Data packet containing the data following an encoded symbol separator character.
	2	Data packet containing the data following an escape mechanism character. The data packet does not support the ECI protocol.
	3	Data packet containing the data following an escape mechanism character. The data packet supports the ECI protocol.
		GS1-128 emulation Note: UPC portion of composite is transmitted using UPC rules.
	1	Data packet is a GS1-128 symbol (i.e., data is preceded with ]C1).
PDF417, Micro PDF417	0	Reader set to conform to protocol defined in 1994 PDF417 symbology specifications. <b>Note:</b> When this option is transmitted, the receiver cannot reliably determine whether ECIs have been invoked or whether data byte 92 <sub>DEC</sub> has been doubled in transmission.
	1	Reader set to follow the ECI protocol (Extended Channel Interpretation). All data characters 92 <sub>DEC</sub> are doubled.
	2	Reader set for Basic Channel operation (no escape character transmission protocol). Data characters 92 <sub>DEC</sub> are not doubled. <b>Note:</b> When decoders are set to this mode, unbuffered Macro symbols and symbols requiring the decoder to convey ECI escape sequences cannot be transmitted.
	3	The bar code contains a GS1-128 symbol, and the first codeword is 903-907, 912, 914, 915.
	4	The bar code contains a GS1-128 symbol, and the first codeword is in the range 908-909.
	5	The bar code contains a GS1-128 symbol, and the first codeword is in the range 910-911.
Example: A PDF417 bar code ABCD, with no transmission protocol enabled, is transmitted as ]L2ABCD.		

**Table B-3** *Modifier Characters (Continued)*

<b>Code Type</b>	<b>Option Value</b>	<b>Option</b>
Data Matrix	0	ECC 000-140, not supported.
	1	ECC 200.
	2	ECC 200, FNC1 in first or fifth position.
	3	ECC 200, FNC1 in second or sixth position.
	4	ECC 200, ECI protocol implemented.
	5	ECC 200, FNC1 in first or fifth position, ECI protocol implemented.
	6	ECC 200, FNC1 in second or sixth position, ECI protocol implemented.
MaxiCode	0	Symbol in Mode 4 or 5.
	1	Symbol in Mode 2 or 3.
	2	Symbol in Mode 4 or 5, ECI protocol implemented.
	3	Symbol in Mode 2 or 3, ECI protocol implemented in secondary message.
QR Code	0	Model 1 symbol.
	1	Model 2 / MicroQR symbol, ECI protocol not implemented.
	2	Model 2 symbol, ECI protocol implemented.
	3	Model 2 symbol, ECI protocol not implemented, FNC1 implied in first position.
	4	Model 2 symbol, ECI protocol implemented, FNC1 implied in first position.
	5	Model 2 symbol, ECI protocol not implemented, FNC1 implied in second position.
	6	Model 2 symbol, ECI protocol implemented, FNC1 implied in second position.
Aztec	0	Aztec symbol.
	C	Aztec Rune symbol.



# Appendix C Sample Bar Codes



**NOTE** Enable the code type of each sample bar code in order to decode that bar code.  
See [Chapter 13, Symbologies](#).

---

## UPC-A



---

## UPC-E



---

## UPC-E1



---

## EAN-13



---

## EAN-8



---

**Code 39**



123ABC

---

**Trioptic Code 39**



123456

---

**Code 93**



12345ABCDE

---

**Code 11**



Æ1234567890Æ

---

## Codabar



---

## MSI



---

## Interleaved 2 of 5



---

## GS1 DataBar-14





---

## PDF417



12345678910abcdefghijklmnopqrstuvwxy

---

## Data Matrix



123456789abcdefghijklmnopqrstuvwxy

---

## Maxicode

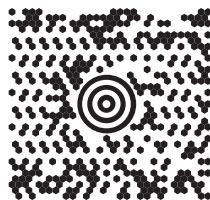

12345600001666Symbol Technologies

---

## QR Code



0123456789ABCDEFGHIJKLMNOPQRSTUVWXYZ0123456789ABCDEFGHIJKLMNOPQRSTUVWXYZ0123456789

---

## US Postnet



---

## UK Postal



# Appendix D Numeric Bar Codes

---

## 0, 1, 2, 3

For parameters requiring specific numeric values, scan the numbered bar code(s).



0



1

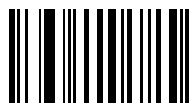

2



3

---

**4, 5, 6, 7**

For parameters requiring specific numeric values, scan the numbered bar code(s).



**4**

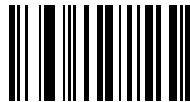

**5**



**6**



**7**

---

**8, 9**

For parameters requiring specific numeric values, scan the numbered bar code(s).



8

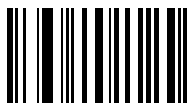

9

---

**Cancel**

In case of an error or to change the selection, scan the bar code below.



Cancel



# Glossary

---

## A

**Aperture.** The opening in an optical system defined by a lens or baffle that establishes the field of view.

**API.** An interface by means of which one software component communicates with or controls another. Usually used to refer to services provided by one software component to another, usually via software interrupts or function calls

**Application Programming Interface.** See **API**.

**ASCII.** American Standard Code for Information Interchange. A 7 bit-plus-parity code representing 128 letters, numerals, punctuation marks and control characters. It is a standard data transmission code in the U.S.

**Autodiscrimination.** The ability of an interface controller to determine the code type of a scanned bar code. After this determination is made, the information content is decoded.

---

## B

**Bar.** The dark element in a printed bar code symbol.

**Bar Code.** A pattern of variable-width bars and spaces which represents numeric or alphanumeric data in machine-readable form. The general format of a bar code symbol consists of a leading margin, start character, data or message character, check character (if any), stop character, and trailing margin. Within this framework, each recognizable symbology uses its own unique format. See **Symbology**.

**Bar Code Density.** The number of characters represented per unit of measurement (e.g., characters per inch).

**Bar Height.** The dimension of a bar measured perpendicular to the bar width.

**Bar Width.** Thickness of a bar measured from the edge closest to the symbol start character to the trailing edge of the same bar.

**BIOS.** Basic Input Output System. A collection of ROM-based code with a standard API used to interface with standard PC hardware.

**Bit.** Binary digit. One bit is the basic unit of binary information. Generally, eight consecutive bits compose one byte of data. The pattern of 0 and 1 values within the byte determines its meaning.

**Bits per Second (bps).** Bits transmitted or received.

**Boot or Boot-up.** The process a computer goes through when it starts. During boot-up, the computer can run self-diagnostic tests and configure hardware and software.

**BOOTP.** A protocol for remote booting of diskless devices. Assigns an IP address to a machine and may specify a boot file. The client sends a bootp request as a broadcast to the bootp server port (67) and the bootp server responds using the bootp client port (68). The bootp server must have a table of all devices, associated MAC addresses and IP addresses.

**bps.** See **Bits Per Second**.

**Byte.** On an addressable boundary, eight adjacent binary digits (0 and 1) combined in a pattern to represent a specific character or numeric value. Bits are numbered from the right, 0 through 7, with bit 0 the low-order bit. One byte in memory is used to store one ASCII character.

---

## C

**CDRH.** Center for Devices and Radiological Health. A federal agency responsible for regulating laser product safety. This agency specifies various laser operation classes based on power output during operation.

**CDRH Class 1.** This is the lowest power CDRH laser classification. This class is considered intrinsically safe, even if all laser output were directed into the eye's pupil. There are no special operating procedures for this class.

**CDRH Class 2.** No additional software mechanisms are needed to conform to this limit. Laser operation in this class poses no danger for unintentional direct human exposure.

**Character.** A pattern of bars and spaces which either directly represents data or indicates a control function, such as a number, letter, punctuation mark, or communications control contained in a message.

**Character Set.** Those characters available for encoding in a particular bar code symbology.

**Check Digit.** A digit used to verify a correct symbol decode. The scanner inserts the decoded data into an arithmetic formula and checks that the resulting number matches the encoded check digit. Check digits are required for UPC but are optional for other symbologies. Using check digits decreases the chance of substitution errors when a symbol is decoded.

**Codabar.** A discrete self-checking code with a character set consisting of digits 0 to 9 and six additional characters: ( - \$ : / , +).

**Code 128.** A high density symbology which allows the controller to encode all 128 ASCII characters without adding extra symbol elements.

**Code 3 of 9 (Code 39).** A versatile and widely used alphanumeric bar code symbology with a set of 43 character types, including all uppercase letters, numerals from 0 to 9 and 7 special characters ( - . / + % \$ and space). The code name is derived from the fact that 3 of 9 elements representing a character are wide, while the remaining 6 are narrow.

**Code 93.** An industrial symbology compatible with Code 39 but offering a full character ASCII set and a higher coding density than Code 39.



**Code Length.** Number of data characters in a bar code between the start and stop characters, not including those characters.

**Cold Boot.** A cold boot restarts the mobile computer and erases all user stored records and entries.

**COM Port.** Communication port; ports are identified by number, e.g., COM1, COM2.

**Continuous Code.** A bar code or symbol in which all spaces within the symbol are parts of characters. There are no intercharacter gaps in a continuous code. The absence of gaps allows for greater information density.

**Cradle.** A cradle is used for charging the terminal battery and for communicating with a host computer, and provides a storage place for the terminal when not in use.

---

## D

**Dead Zone.** An area within a scanner's field of view, in which specular reflection may prevent a successful decode.

**Decode.** To recognize a bar code symbology (e.g., UPC/EAN) and then analyze the content of the specific bar code scanned.

**Decode Algorithm.** A decoding scheme that converts pulse widths into data representation of the letters or numbers encoded within a bar code symbol.

**Decryption.** Decryption is the decoding and unscrambling of received encrypted data. Also see, **Encryption** and **Key**.

**Depth of Field.** The range between minimum and maximum distances at which a scanner can read a symbol with a certain minimum element width.

**Discrete 2 of 5.** A binary bar code symbology representing each character by a group of five bars, two of which are wide. The location of wide bars in the group determines which character is encoded; spaces are insignificant. Only numeric characters (0 to 9) and START/STOP characters may be encoded.

**Discrete Code.** A bar code or symbol in which the spaces between characters (intercharacter gaps) are not part of the code.

**DRAM.** Dynamic random access memory.

---

## E

**EAN.** European Article Number. This European/International version of the UPC provides its own coding format and symbology standards. Element dimensions are specified metrically. EAN is used primarily in retail.

**Element.** Generic term for a bar or space.

**Encoded Area.** Total linear dimension occupied by all characters of a code pattern, including start/stop characters and data.

**ENQ (RS-232).** ENQ software handshaking is also supported for the data sent to the host.

**ESD.** Electro-Static Discharge

---

## F

**Flash Disk.** An additional megabyte of non-volatile memory for storing application and configuration files.

**Flash Memory.** Flash memory is responsible for storing the system firmware and is non-volatile. If the system power is interrupted the data is not be lost.

**FTP.** See **File Transfer Protocol**.

---

## H

**Hard Reset.** See **Cold Boot**.

**Host Computer.** A computer that serves other terminals in a network, providing such services as computation, database access, supervisory programs and network control.

**Hz.** Hertz; A unit of frequency equal to one cycle per second.

---

## I

**IDE.** Intelligent drive electronics. Refers to the solid-state hard drive type.

**IEC.** International Electrotechnical Commission. This international agency regulates laser safety by specifying various laser operation classes based on power output during operation.

**IEC (825) Class 1.** This is the lowest power IEC laser classification. Conformity is ensured through a software restriction of 120 seconds of laser operation within any 1000 second window and an automatic laser shutdown if the scanner's oscillating mirror fails.

**Input/Output Ports.** I/O ports are primarily dedicated to passing information into or out of the device's memory, such as serial and USB ports.

**Intercharacter Gap.** The space between two adjacent bar code characters in a discrete code.

**Interleaved 2 of 5.** A binary bar code symbology representing character pairs in groups of five bars and five interleaved spaces. Interleaving provides for greater information density. The location of wide elements (bar/spaces) within each group determines which characters are encoded. This continuous code type uses no intercharacter spaces. Only numeric (0 to 9) and START/STOP characters may be encoded.

**Interleaved Bar Code.** A bar code in which characters are paired together, using bars to represent the first character and the intervening spaces to represent the second.

**I/O Ports.** interface The connection between two devices, defined by common physical characteristics, signal characteristics, and signal meanings. Types of interfaces include RS-232 and PCMCIA.

**IOCTL.** Input/Output Control.

**IP.** Internet Protocol. The IP part of the TCP/IP communications protocol. IP implements the network layer (layer 3) of the protocol, which contains a network address and is used to route a message to a different network or subnetwork. IP accepts “packets” from the layer 4 transport protocol (TCP or UDP), adds its own header to it and delivers a “datagram” to the layer 2 data link protocol. It may also break the packet into fragments to support the maximum transmission unit (MTU) of the network.

**IP Address.** (Internet Protocol address) The address of a computer attached to an IP network. Every client and server station must have a unique IP address. A 32-bit address used by a computer on a IP network. Client workstations have either a permanent address or one that is dynamically assigned to them each session. IP addresses are written as four sets of numbers separated by periods; for example, 204.171.64.2.

**IPX/SPX.** Internet Package Exchange/Sequential Packet Exchange. A communications protocol for Novell. IPX is Novell's Layer 3 protocol, similar to XNS and IP, and used in NetWare networks. SPX is Novell's version of the Xerox SPP protocol.

---

## K

**Key.** A key is the specific code used by the algorithm to encrypt or decrypt the data. Also see, **Encryption** and **Decrypting**.

---

## L

**LASER.** Light Amplification by Stimulated Emission of Radiation. The laser is an intense light source. Light from a laser is all the same frequency, unlike the output of an incandescent bulb. Laser light is typically coherent and has a high energy density.

**Laser Diode.** A gallium-arsenide semiconductor type of laser connected to a power source to generate a laser beam. This laser type is a compact source of coherent light.

**Laser Scanner.** A type of bar code reader that uses a beam of laser light.

**LCD.** See **Liquid Crystal Display**.

**LED Indicator.** A semiconductor diode (LED - Light Emitting Diode) used as an indicator, often in digital displays. The semiconductor uses applied voltage to produce light of a certain frequency determined by the semiconductor's particular chemical composition.

**Light Emitting Diode.** See **LED**.

**Liquid Crystal Display (LCD).** A display that uses liquid crystal sealed between two glass plates. The crystals are excited by precise electrical charges, causing them to reflect light outside according to their bias. They use little electricity and react relatively quickly. They require external light to reflect their information to the user.

---

## M

**MDN.** Mobile Directory Number. The directory listing telephone number that is dialed (generally using POTS) to reach a mobile unit. The MDN is usually associated with a MIN in a cellular telephone -- in the US and Canada, the MDN and

MIN are the same value for voice cellular users. International roaming considerations often result in the MDN being different from the MIN.

**MIL.** 1 mil = 1 thousandth of an inch.

**MIN.** Mobile Identification Number. The unique account number associated with a cellular device. It is broadcast by the cellular device when accessing the cellular system.

**Misread (Misdecode).** A condition which occurs when the data output of a reader or interface controller does not agree with the data encoded within a bar code symbol.

---

## N

**Nominal.** The exact (or ideal) intended value for a specified parameter. Tolerances are specified as positive and negative deviations from this value.

**Nominal Size.** Standard size for a bar code symbol. Most UPC/EAN codes are used over a range of magnifications (e.g., from 0.80 to 2.00 of nominal).

**NVM.** Non-Volatile Memory.

---

## O

**ODI.** See **Open Data-Link Interface**.

**Open Data-Link Interface (ODI).** Novell's driver specification for an interface between network hardware and higher-level protocols. It supports multiple protocols on a single NIC (Network Interface Controller). It is capable of understanding and translating any network information or request sent by any other ODI-compatible protocol into something a NetWare client can understand and process.

**Open System Authentication.** Open System authentication is a null authentication algorithm.

---

## P

**PAN .** Personal area network. Using Bluetooth wireless technology, PANs enable devices to communicate wirelessly. Generally, a wireless PAN consists of a dynamic group of less than 255 devices that communicate within about a 33-foot range. Only devices within this limited area typically participate in the network.

**Parameter.** A variable that can have different values assigned to it.

**PC Card.** A plug-in expansion card for laptop computers and other devices, also called a PCMCIA card. PC Cards are 85.6mm long x 54 mm wide, and have a 68 pin connector. There are several different kinds:

- Type I; 3.3 mm high; use - RAM or Flash RAM
- Type II; 5 mm high; use - modems, LAN adaptors
- Type III; 10.5 high; use - Hard Disks

**PCMCIA.** Personal Computer Memory Card Interface Association. See **PC Card**.

**Percent Decode.** The average probability that a single scan of a bar code would result in a successful decode. In a well-designed bar code scanning system, that probability should approach near 100%.

**PING.** (Packet Internet Groper) An Internet utility used to determine whether a particular IP address is online. It is used to test and debug a network by sending out a packet and waiting for a response.

**Print Contrast Signal (PCS).** Measurement of the contrast (brightness difference) between the bars and spaces of a symbol. A minimum PCS value is needed for a bar code symbol to be scannable.  $PCS = (RL - RD) / RL$ , where RL is the reflectance factor of the background and RD the reflectance factor of the dark bars.

**Programming Mode.** The state in which a scanner is configured for parameter values. See **Scanning Mode**.

---

## Q

**Quiet Zone.** A clear space, containing no dark marks, which precedes the start character of a bar code symbol and follows the stop character.

**QWERTY.** A standard keyboard commonly used on North American and some European PC keyboards. "QWERTY" refers to the arrangement of keys on the left side of the third row of keys.

---

## R

**RAM.** Random Access Memory. Data in RAM can be accessed in random order, and quickly written and read.

**Reflectance.** Amount of light returned from an illuminated surface.

**Resolution.** The narrowest element dimension which is distinguished by a particular reading device or printed with a particular device or method.

**RF.** Radio Frequency.

**ROM.** Read-Only Memory. Data stored in ROM cannot be changed or removed.

**Router.** A device that connects networks and supports the required protocols for packet filtering. Routers are typically used to extend the range of cabling and to organize the topology of a network into subnets. See **Subnet**.

**RS-232.** An Electronic Industries Association (EIA) standard that defines the connector, connector pins, and signals used to transfer data serially from one device to another.

---

## S

**Scan Area.** Area intended to contain a symbol.

**Scanner.** An electronic device used to scan bar code symbols and produce a digitized pattern that corresponds to the bars and spaces of the symbol. Its three main components are: 1) Light source (laser or photoelectric cell) - illuminates a bar code;; 2) Photodetector - registers the difference in reflected light (more light reflected from spaces); 3) Signal conditioning circuit - transforms optical detector output into a digitized bar pattern.

**Scanning Mode.** The scanner is energized, programmed and ready to read a bar code.

**Scanning Sequence.** A method of programming or configuring parameters for a bar code reading system by scanning bar code menus.

**SDK.** Software Development Kit

**Self-Checking Code.** A symbology that uses a checking algorithm to detect encoding errors within the characters of a bar code symbol.

**Shared Key.** Shared Key authentication is an algorithm where both the AP and the MU share an authentication key.

**SHIP.** Symbol Host Interface Program.

**SID.** System Identification code. An identifier issued by the FCC for each market. It is also broadcast by the cellular carriers to allow cellular devices to distinguish between the home and roaming service.

**Soft Reset.** See **Warm Boot.**

**Space.** The lighter element of a bar code formed by the background between bars.

**Specular Reflection.** The mirror-like direct reflection of light from a surface, which can cause difficulty decoding a bar code.

**Start/Stop Character.** A pattern of bars and spaces that provides the scanner with start and stop reading instructions and scanning direction. The start and stop characters are normally to the left and right margins of a horizontal code.

**STEP.** Symbol Terminal Enabler Program.

**Subnet.** A subset of nodes on a network that are serviced by the same router. See **Router.**

**Subnet Mask.** A 32-bit number used to separate the network and host sections of an IP address. A custom subnet mask subdivides an IP network into smaller subsections. The mask is a binary pattern that is matched up with the IP address to turn part of the host ID address field into a field for subnets. Default is often 255.255.255.0.

**Substrate.** A foundation material on which a substance or image is placed.

**SVTP.** Symbol Virtual Terminal Program.

**Symbol.** A scannable unit that encodes data within the conventions of a certain symbology, usually including start/stop characters, quiet zones, data characters and check characters.

**Symbol Aspect Ratio.** The ratio of symbol height to symbol width.

**Symbol Height.** The distance between the outside edges of the quiet zones of the first row and the last row.

**Symbol Length.** Length of symbol measured from the beginning of the quiet zone (margin) adjacent to the start character to the end of the quiet zone (margin) adjacent to a stop character.

**Symbology.** The structural rules and conventions for representing data within a particular bar code type (e.g. UPC/EAN, Code 39, PDF417, etc.).

---

## T

**TCP/IP.** (Transmission Control Protocol/Internet Protocol) A communications protocol used to internetwork dissimilar systems. This standard is the protocol of the Internet and has become the global standard for communications. TCP provides transport functions, which ensures that the total amount of bytes sent is received correctly at the other end. UDP is an alternate transport that does not guarantee delivery. It is widely used for real-time voice and video transmissions where erroneous packets are not retransmitted. IP provides the routing mechanism. TCP/IP is a routable protocol, which means that all messages contain not only the address of the destination station, but the address of a destination network. This allows TCP/IP messages to be sent to multiple networks within an organization or around the world, hence its use in the worldwide Internet. Every client and server in a TCP/IP network requires an IP address, which is either permanently assigned or dynamically assigned at startup.

**Telnet.** A terminal emulation protocol commonly used on the Internet and TCP/IP-based networks. It allows a user at a terminal or computer to log onto a remote device and run a program.

**Terminal Emulation.** A “terminal emulation” emulates a character-based mainframe session on a remote non-mainframe terminal, including all display features, commands and function keys. The VC5000 Series supports Terminal Emulations in 3270, 5250 and VT220.

**Terminate and Stay Resident (TSR).** A program under DOS that ends its foreground execution to remain resident in memory to service hardware/software interrupts, providing background operation. It remains in memory and may provide services on behalf of other DOS programs.

**TFTP.** (Trivial File Transfer Protocol) A version of the TCP/IP FTP (File Transfer Protocol) protocol that has no directory or password capability. It is the protocol used for upgrading firmware, downloading software and remote booting of diskless devices.

**Tolerance.** Allowable deviation from the nominal bar or space width.

**Transmission Control Protocol/Internet Protocol.** See **TCP/IP**.

**Trivial File Transfer Protocol.** See **TFTP**.

**TSR.** See **Terminate and Stay Resident**.

---

## U

**UDP.** User Datagram Protocol. A protocol within the IP protocol suite that is used in place of TCP when a reliable delivery is not required. For example, UDP is used for real-time audio and video traffic where lost packets are simply ignored, because there is no time to retransmit. If UDP is used and a reliable delivery is required, packet sequence checking and error notification must be written into the applications.

**UPC.** Universal Product Code. A relatively complex numeric symbology. Each character consists of two bars and two spaces, each of which is any of four widths. The standard symbology for retail food packages in the United States.

---

## V

**Visible Laser Diode (VLD).** A solid state device which produces visible laser light.

---

## W

**Warm Boot.** A warm boot restarts the mobile computer by closing all running programs. All data that is not saved to flash memory is lost.



# Index

## Numerics

123Scan	12-1
2D bar codes	
aztec	13-75
aztec inverse	13-75
code 128 emulation	13-70
Data Matrix	13-71
Data Matrix inverse	13-71
Maxicode	13-72
MicroPDF417	13-69
MicroQR	13-74
PDF417	13-69
QR code	13-73
QR inverse	13-73

## A

actions	15-2
ADF	15-1
actions	15-1, 15-27
move cursor	15-31
send data	15-27
setup fields	15-31
alphanumeric keyboard	15-90
alternate rule sets	15-3
bar code list	15-6
bar code menu example	15-2
beep	15-46
code lengths	15-18
code types	15-11
criteria	15-1, 15-11
default rules	15-5
move cursor past a character	15-31
move cursor to a character	15-31
move cursor to start of data	15-31
numeric keypad	15-24, 15-25

pad spaces	15-37
pad zeros	15-41
rules	15-1
rules hierarchy	15-5
send alt characters	15-65
send control characters	15-46
send function key	15-75
send keyboard characters	15-51
send keypad characters	15-70
send value	15-35
skip ahead characters	15-32
skip back characters	15-33
space removal	15-36
special commands	15-8
specific data string	15-23
specific string	
any location	15-23
any message ok	15-23
at start	15-23
rule belongs to set	15-26
turn off rule sets	15-89
turn on rule sets	15-88
zero removal	15-36
advanced data formatting	15-1
actions	15-1, 15-27
alphanumeric keyboard	15-90
alternate rule sets	15-3
bar code menu example	15-2
beep	15-46
code lengths	15-18
code types	15-11
criteria	15-1, 15-11
default rules	15-5
numeric keypad	15-24, 15-25
pad spaces	15-37
pad zeros	15-41
rules	15-1

rules hierarchy	15-5
send alt characters	15-65
send control characters	15-46
send function key	15-75
send keyboard characters	15-51
send keypad characters	15-70
send preset value	15-35
setup fields	15-31
skip ahead characters	15-32
skip back characters	15-33
space removal	15-36
special commands	15-8
specific data string	15-23
turn off rule sets	15-89
turn on rule sets	15-88
zero removal	15-36
AIM code identifiers	B-3
aiming	2-7
decode aiming pattern	5-4
aiming pattern	2-6
enabling	5-4
orientation	2-6, 2-7
ASCII character set	6-14, 7-20, 8-11

## B

bar codes	
123Scan	12-1
ADF	15-8
ADF list	15-6
aztec	13-75
aztec inverse	13-75
beep after good decode	4-6
beeper tone	4-4
beeper volume	4-5
bookland ISBN	13-21
cancel	D-3
code 128 emulation	13-70
code 39	
transmit buffer	13-35
composite CC-A/B	13-66
composite CC-C	13-66
composite TLC-39	13-67
connection maintenance interval	4-10
Data Matrix	13-71
Data Matrix inverse	13-71
data options	
pause duration	15-8
prefix/suffix values	14-4
transmit code ID character	14-3
decode aiming pattern	5-4
decode mirror images	4-9
decode session timeout	4-8
direct part marking	5-5

DPM	5-5
flush macro buffer/abort macro PDF entry	13-81
FN1 substitution values	14-6
focus mode	5-3
fuzzy 1D decoding	4-8
IBM 468X/469X	9-4
convert unknown to code 39	9-5
default parameters	9-3
port address	9-4
illumination	5-4
interleaved 2 of 5	13-42
keyboard wedge	6-4
alternate numeric keypad emulation	6-8
caps lock on	6-9
caps lock override	6-9
convert wedge data	6-10
country keyboard types	6-5
default table	6-3
FN1 substitution	6-11
function key mapping	6-10
host types	6-4
ignore unknown characters	6-7
intra-keystroke delay	6-8
keystroke delay	6-7
send make and break	6-11
Maxicode	13-72
MicroPDF417	13-69
MicroQR	13-74
miscellaneous	
FN1 substitution values	14-6
prefix/suffix values	14-4
scan data options	14-5
transmit code ID	14-3
transmit no read message	14-7
numeric bar codes	D-1
parameter broadcast	4-12
parameter scanning	4-3
PDF417	13-69
picklist mode	4-7
postal	13-59
power mode	4-5
prefix/suffix values	14-4
QR code	13-73
QR inverse	13-73
radio output power	4-12
RS-232	
baud rate	7-7
beep on BEL	7-16
beep on bel	7-16
check receive errors	7-10
data bits	7-11
default table	7-3
hardware handshaking	7-11
host serial response time-out	7-15

- host types . . . . . 7-6
- ignore unknown characters . . . . . 7-19
- intercharacter delay . . . . . 7-17
- Nixdorf mode . . . . . 7-18
- parity . . . . . 7-9
- RTS line state . . . . . 7-16
- software handshaking . . . . . 7-13
- stop bits . . . . . 7-10
- sample . . . . . C-1
- scan data options . . . . . 14-5
- scanner emulation
  - beep style . . . . . 11-4
  - check for decode LED . . . . . 11-12
  - code 39 full ASCII conversion . . . . . 11-8
  - convert all bar codes to code 39 . . . . . 11-7
  - convert newer code types . . . . . 11-6
  - default table . . . . . 11-3
  - ignore unknown characters . . . . . 11-10
  - leading margin . . . . . 11-11
  - module width . . . . . 11-7
  - parameter pass through . . . . . 11-5
  - scanner emulation host . . . . . 11-4
  - transmission timeout . . . . . 11-9
- set defaults . . . . . 4-3
- single point and multipoint . . . . . 4-13
- symbolologies
  - Australian postal . . . . . 13-62
  - bookland EAN . . . . . 13-9
  - buffering . . . . . 13-34
  - Chinese 2 of 5 . . . . . 13-54
  - codabar . . . . . 13-48
  - codabar CLSI editing . . . . . 13-50
  - codabar lengths . . . . . 13-48
  - codabar NOTIS editing . . . . . 13-50
  - code 11 . . . . . 13-38
  - code 11 check digit verification . . . . . 13-40
  - code 11 lengths . . . . . 13-38
  - code 128 . . . . . 13-23
  - code 128 lengths . . . . . 13-23
  - code 32 prefix . . . . . 13-29
  - code 39 . . . . . 13-28
  - code 39 check digit verification . . . . . 13-32
  - code 39 full ASCII . . . . . 13-33
  - code 39 lengths . . . . . 13-24, 13-30, 13-31
  - code 39 transmit check digit . . . . . 13-32
  - code 93 . . . . . 13-36
  - code 93 lengths . . . . . 13-36, 13-37, 13-39
  - composite codes . . . . . 13-66
  - convert code 39 to code 32 . . . . . 13-29
  - convert GS1 DataBar to UPC/EAN . . . . . 13-65
  - convert UPC-E to UPC-A . . . . . 13-19
  - convert UPC-E1 to UPC-A . . . . . 13-19
  - Data Matrix . . . . . 13-71
  - default table . . . . . 13-2
  - discrete 2 of 5 . . . . . 13-46
  - discrete 2 of 5 lengths . . . . . 13-46, 13-47, 13-49
  - EAN zero extend . . . . . 13-20
  - EAN-13 . . . . . 13-8
  - EAN-8 . . . . . 13-9
  - GS1 DataBar . . . . . 13-64
  - GS1 DataBar expanded . . . . . 13-65
  - GS1 DataBar limited . . . . . 13-64
  - GS1 DataBar-14 . . . . . 13-64
  - GS1-128 . . . . . 13-25
  - I 2 of 5 check digit verification . . . . . 13-44
  - I 2 of 5 convert to EAN-13 . . . . . 13-45
  - I 2 of 5 transmit check digit . . . . . 13-44
  - interleaved 2 of 5 lengths . . . . . 13-42, 13-43
  - inverse 1D . . . . . 13-58
  - ISBT 128 . . . . . 13-25
  - ISBT concatenation . . . . . 13-26, 13-27
  - ISBT concatenation redundancy . . . . . 13-27
  - ISSN EAN . . . . . 13-22
  - Japan postal . . . . . 13-61
  - matrix 2 of 5 . . . . . 13-55
  - matrix 2 of 5 check digit . . . . . 13-57
  - matrix 2 of 5 lengths . . . . . 13-56
  - matrix 2 of 5 redundancy . . . . . 13-57
  - Maxicode . . . . . 13-72
  - MicroPDF417 . . . . . 13-69
  - MSI . . . . . 13-51
  - MSI check digit algorithm . . . . . 13-54
  - MSI check digits . . . . . 13-53
  - MSI lengths . . . . . 13-51
  - MSI transmit check digit . . . . . 13-53
  - Netherlands KIX code . . . . . 13-62
  - PDF417 . . . . . 13-69
  - QR code . . . . . 13-73
  - redundancy level . . . . . 13-76
  - security level . . . . . 13-78
  - supplementals . . . . . 13-10
  - transmit code 11 check digits . . . . . 13-41
  - transmit matrix 2 of 5 check digit . . . . . 13-58
  - transmit UK postal check digit . . . . . 13-61
  - transmit US postal check digit . . . . . 13-60
  - trioptic code 39 . . . . . 13-28
  - UCC coupon extended code . . . . . 13-22
  - UK postal . . . . . 13-60
  - UPC/EAN supp redundancy . . . . . 13-13
  - UPC-A . . . . . 13-7
  - UPC-A preamble . . . . . 13-16
  - UPC-A/E/E1 check digit . . . . . 13-14
  - UPC-E . . . . . 13-7
  - UPC-E preamble . . . . . 13-17
  - UPC-E1 . . . . . 13-8
  - UPC-E1 preamble . . . . . 13-18
  - UPU FICS postal . . . . . 13-63
  - US planet . . . . . 13-59

- US postnet ..... 13-59
  - transmit code ID ..... 14-3
  - transmit no read message ..... 14-7
  - unpair ..... 4-13
  - UPC composite mode ..... 13-67
  - UPC/EAN
    - coupon code ..... 13-22
  - USB
    - caps lock override ..... 8-7
    - convert case ..... 8-10
    - country keyboard types ..... 8-5
    - default table ..... 8-3
    - device type ..... 8-4
    - emulate keypad ..... 8-8
    - function key mapping ..... 8-9
    - keyboard FN 1 substitution ..... 8-9
    - keystroke delay ..... 8-7
    - simulated caps lock ..... 8-10
    - unknown characters ..... 8-8
  - USPS 4CB/one code/intelligent mail ..... 13-63
  - wand emulation
    - code 39 full ASCII ..... 10-8
    - convert all to code 39 ..... 10-7
    - default table ..... 10-3
    - host types ..... 10-4
    - leading margin (quiet zone) ..... 10-5
    - polarity ..... 10-6
    - unknown characters ..... 10-6
  - battery
    - charging ..... 1-8
    - charging problems ..... 1-8
    - inserting ..... 1-7
    - removing ..... 1-7
  - beeper
    - definitions ..... 2-2
    - setting tone ..... 4-4
    - setting volume ..... 4-5
- C**
- cables
    - installing ..... 1-4
  - chapter descriptions ..... xv
  - character set ..... 7-20, 8-11
  - charging
    - LEDs ..... 1-8
    - problems ..... 1-8
    - via host ..... 1-5
  - cleaning ..... 3-1
  - codabar bar codes
    - CLSI editing ..... 13-50
    - codabar ..... 13-48
    - lengths ..... 13-48
    - NOTIS editing ..... 13-50
  - code 11 bar codes
    - code 11 ..... 13-38
    - lengths ..... 13-38
  - code 128 bar codes
    - code 128 ..... 13-23
    - GS1-128 ..... 13-25
    - ISBT concatenation ..... 13-26, 13-27
    - ISBT concatenation redundancy ..... 13-27
    - lengths ..... 13-23
  - code 128 emulation bar codes ..... 13-70
  - code 39 bar codes
    - buffering ..... 13-34
    - check digit verification ..... 13-32
    - code 39 ..... 13-28
    - full ASCII ..... 13-33
    - lengths ..... 13-24, 13-30, 13-31
    - transmit check digit ..... 13-32
  - code 93 bar codes
    - code 93 ..... 13-36
    - lengths ..... 13-36, 13-37, 13-39
  - code identifiers
    - AIM code identifiers ..... B-3
    - modifier characters ..... B-4
    - Symbol code identifiers ..... B-1
  - code types
    - ADF ..... 15-11
  - composite bar codes
    - composite CC-A/B ..... 13-66
    - composite CC-C ..... 13-66
    - composite TLC-39 ..... 13-67
    - UPC composite mode ..... 13-67
  - configurations ..... xv
  - configuring scanner ..... 1-10
    - 123Scan ..... 12-1
  - connecting
    - IBM host ..... 9-2
    - keyboard wedge ..... 6-2
    - lost connection ..... 1-6
    - RS-232 ..... 7-2
    - scanner emulation ..... 11-2
    - Synapse interface ..... 1-6
    - USB ..... 8-1
    - wand emulation ..... 10-2
  - cradle ..... 1-2
    - connecting ..... 1-4
    - diagram ..... 1-3, 1-4
    - inserting scanner ..... 1-9
    - mounting ..... 1-6
    - pinouts ..... 3-7, 3-8
    - specifications ..... 3-6
    - supply power ..... 1-5

**D**

Data Matrix bar codes	13-71
decode zones	
DS3478-HD, DPM far focus	2-14
DS3478-HD, DPM near focus	2-12
DS3478-HD, DPM near focus, 2D	2-13
DS3478-HD, DPM smart focus	2-15
DS3478-SF far focus	2-10
DS3478-SF near focus	2-8
DS3478-SF near focus, 2D	2-9
DS3478-SF smart focus	2-11
decoding preferences parameters	5-2
default parameters	4-2
decoding preferences	5-2
IBM 468X/469X	9-3
keyboard wedge	6-3
miscellaneous scanner options	14-2
RS-232	7-3
scanner emulation	11-3
standard default table	A-1
sybologies	13-2
USB	8-3
user preferences	4-2
wand emulation	10-3
direct part marking	2-6
bar codes	5-5
scanning	2-7
discrete 2 of 5 bar codes	
discrete 2 of 5	13-46
lengths	13-46, 13-47, 13-49
DPM	2-6
bar codes	5-5
scanning	2-7

**E**

exposure options	
illumination	5-4

**F**

focus mode	5-3
------------	-----

**H**

host types	
keyboard wedge	6-4
RS-232	7-6
wand emulation	10-4

**I**

IBM 468X/469X connection	9-2
--------------------------	-----

IBM 468X/469X default parameters	9-3
illumination	5-4
information, service	xvii
inserting battery	1-7
interfaces supported	1-2
interleaved 2 of 5 bar codes	
check digit verification	13-44
convert to EAN-13	13-45
transmit check digit	13-44
ISBT 128 bar codes	
ISBT 128	13-25

**K**

keyboard maps	6-12
keyboard wedge connection	6-2
keyboard wedge default parameters	6-3

**L**

LED definitions	2-5
-----------------	-----

**M**

macro PDF	13-81
flush buffer/abort PDF entry	13-81
maintenance	3-1
matrix 2 of 5 bar codes	13-55
check digit	13-57
lengths	13-56
redundancy	13-57
transmit check digit	13-58
Maxicode bar codes	13-72
MicroPDF417 bar codes	13-69
miscellaneous scanner parameters	14-2
mounting	
cradle	1-6
MSI bar codes	
check digit algorithm	13-54
check digits	13-53
lengths	13-51
MSI	13-51
transmit check digit	13-53
multipoint mode	1-2
charging	1-5
multipoint operation	
selecting	4-13

**N**

Near	2-9
notational conventions	xvi

**P**

pairing ..... 1-9  
 PDF417 bar codes ..... 13-69  
 pinouts ..... 3-7  
 postal codes ..... 13-59  
     Austalian postal ..... 13-62  
     Japan postal ..... 13-61  
     Netherlands KIX code ..... 13-62  
     transmit UK postal check digit ..... 13-61  
     transmit US postal check digit ..... 13-60  
     UK postal ..... 13-60  
     UPU FICS postal ..... 13-63  
     US planet ..... 13-59  
     US postnet ..... 13-59  
     USPS 4CB/one code/intelligent mail ..... 13-63  
 power ..... 1-5  
     via host ..... 1-5

**Q**

QR code bar codes ..... 13-73  
 quiet zone (leading margin) ..... 10-5

**R**

radio communications ..... 4-10  
 removing battery ..... 1-7  
 RS-232 connection ..... 7-2  
 RS-232 default parameters ..... 7-3  
 RS-232 host types ..... 7-6  
 RS-232 parameters ..... 7-4

**S**

sample bar codes ..... C-1  
 scanner defaults ..... 4-2  
 scanner emulation connection ..... 11-2  
 scanner emulation default parameters ..... 11-3  
 scanning ..... 2-6  
     aiming ..... 2-6, 2-7  
     errors ..... 4-2, 5-2, 13-1, 14-1  
     parameters ..... 4-2  
     sequence example ..... 5-2, 13-1, 14-1  
 service information ..... xvii  
 setup  
     123Scan ..... 12-1  
     connecting a USB interface ..... 8-1  
     connecting an RS-232 interface ..... 7-2  
     connecting keyboard wedge interface ..... 6-2  
     connecting to an IBM 468X/469X host ..... 9-2  
     connecting using scanner emulation ..... 11-2  
     connecting using wand emulation ..... 10-2  
     cradle ..... 1-2

    inserting scanner in cradle ..... 1-9  
     installing the cable ..... 1-4  
     lost host connection ..... 1-6  
     mounting cradle ..... 1-6  
     scanner ..... 1-2  
     supplying power ..... 1-5  
     unpacking ..... 1-2  
 signal descriptions ..... 3-7  
 single point mode ..... 1-2  
     selecting ..... 4-13  
 specifications ..... 3-5  
     cradle ..... 3-6  
 standard default parameters ..... A-1  
 support ..... xvii  
 Symbol code identifiers ..... B-1  
 symbology default parameters ..... 13-2  
 Synapse ..... 1-6

**T**

technical specifications ..... 3-5  
     cradle ..... 3-6  
 troubleshooting ..... 3-2

**U**

unpacking ..... 1-2  
 unpairing ..... 1-10  
     bar code ..... 4-13  
 UPC/EAN bar codes  
     bookland EAN ..... 13-9  
     bookland ISBN ..... 13-21  
     check digit ..... 13-14  
     convert UPC-E to UPC-A ..... 13-19  
     convert UPC-E1 to UPC-A ..... 13-19  
     EAN zero extend ..... 13-20  
     EAN-13 ..... 13-8  
     EAN-8 ..... 13-9  
     ISSN EAN ..... 13-22  
     supplementals ..... 13-10  
     UCC coupon extended code ..... 13-22  
     UPC-A ..... 13-7  
     UPC-A preamble ..... 13-16  
     UPC-E ..... 13-7  
     UPC-E preamble ..... 13-17  
     UPC-E1 ..... 13-8  
 USB connection ..... 8-1  
 USB default parameters ..... 8-3  
 USB parameters ..... 8-4  
 user preferences parameters ..... 4-2

**W**

wand emulation connection ..... 10-2

wand emulation default parameters .....	10-3
wand emulation parameters .....	10-4





# *Tell Us What You Think...*

We'd like to know what you think about this Manual. Please take a moment to fill out this questionnaire and fax this form to: (631) 738-4913, or mail to:

Motorola, Inc.  
One Motorola Plaza M/S B-10  
Holtsville, NY 11742-1300  
Attention: Technical Publications Manager  
Advanced Data Capture Division

**IMPORTANT:** If you need product support, please call the appropriate customer support number provided. Unfortunately, we cannot provide customer support at the fax number above.

Manual Title: \_\_\_\_\_  
(please include revision level)

How familiar were you with this product before using this manual?

Very familiar     Slightly familiar     Not at all familiar

Did this manual meet your needs? If not, please explain.

---

---

---

---

What topics need to be added to the index, if applicable?

---

---

---

---

What topics do you feel need to be better discussed? Please be specific.

---

---

---

---

What can we do to further improve our manuals?

---

---

---

---

Thank you for your input—We value your comments.







**MOTOROLA**

Motorola, Inc.  
One Motorola Plaza  
Holtsville, New York 11742, USA  
1-800-927-9626  
<http://www.motorola.com/enterprisemobility>

MOTOROLA and the Stylized M Logo and Symbol and the Symbol logo are registered in the U.S. Patent and Trademark Office.  
All other product or service names are the property of their respective owners.  
© Motorola, Inc. 2009



72E-72109-05 Revision A - May 2009