

76xx/7200/7400 Utility Interface Box User's Manual

**EM-63217-2E
Rev E**

**SICK Auto Ident, Inc.
5 Shawmut Road
Canton, MA 02021
(781) 302-2500
FAX (781) 828-3150**

Copyright © SICK Auto Ident, Inc.

This manual and the software described in it are copyrighted, with all rights reserved. Under the copyright laws, no part of this publication may be reproduced, stored in a retrieval system, or transmitted, in any form by any means, electronic, mechanical, by photocopying, recording, or otherwise, without prior written permission of SICK Auto Ident, Inc.

Information furnished by SICK Auto Ident, Inc. is believed to be accurate and reliable and is subject to change without notice. However, no responsibility is assumed by SICK Auto Ident, Inc. for its use or any errors that may appear in this document, nor for any infringements of patents or other rights of third parties, which may result from its use.

Factory Authorized Training

SICK Auto Ident, Inc. provides comprehensive product training. Contact the SICK Auto Ident, Inc. Training Coordinator at 1-888-264-4641 for in-house and on-site class schedules and rates.

Getting Assistance

If you have questions or comments, please contact SICK Auto Ident, Inc. at 1-888-264-4641. For additional assistance, contact:

- Order Processing (Option #1)
- Technical Support (Option #2)
- Field Service Contracts (Option #3)
- Customer Service Fax (781) 828-3150

Product names mentioned herein are for identification purposes only and may be trademarks and/or registered trademarks of their respective companies: OMNI, CiComm, CiFrame, CiMenu, CiMAX, CiPRO, CiBOS, Scanstar, Starnode, and TALL. Other references to trademarks are the rights of their respective owners.

Printed in the United States of America

Contents

CHAPTER 1	<i>Setup and Use</i>	1
	Introduction	1
	Features	2
	Description	4
	AC Input Power (A1-63207-2 only)	4
	DC Input Power (A1-63207-3 only)	5
	Making Connections	6
	Scanner to Utility Interface Box	6
	Main and Auxiliary Communications Ports	8
	Presence Sensor Input and Scanner Outputs	10
	Setting LED Output Jumpers	12
	Setting Presence Sensor Jumpers	12

Scanner Setup	14
Setting Scanner Parameters	14
Setting Up for Master/Slave Configurations	17
Setting Up for Pass Through Configurations	19
Technical Specifications	21
Electrical	21
Inputs	21
Outputs	21
Communications	22
Cables	22
Mechanical Assembly	23
Printed Circuit Board	24

<i>Index</i>	25
---------------------	-----------

CHAPTER 1 *Setup and Use*

Introduction

This manual describes the functionality and use of the following products:

- A1-63207-2: 76xx/7200/7400 AC/DC Utility Interface Box
- A1-63207-3: 76xx/7200/7400 DC/DC Utility Interface Box

WARNING! THIS PRODUCT IS INTENDED ONLY FOR INSTALLATION IN AN ELECTRICAL JUNCTION BOX, AND SHOULD BE INSTALLED ONLY BY A QUALIFIED ELECTRICIAN.

Features

The main features of the Utility Boxes are:

- 1 Presence input connection for CiPro-7200/7400, NPN or PNP presence sensor
- 3 input connections for CiMAX-76xx
- 3 output connections
- Main plug-in connector for RS232 or RS485 communication (DB9F)
- Auxiliary plug-in connector for RS232 communication (DB9M)
- Three LEDs controlled by the scanner's output signals (Jumper selectable)

The top plate with the connectors and components must be mounted onto the junction box, as shown in Figure 1.

FIGURE 1. 76xx/7200/7400 AC/DC Utility Interface Box

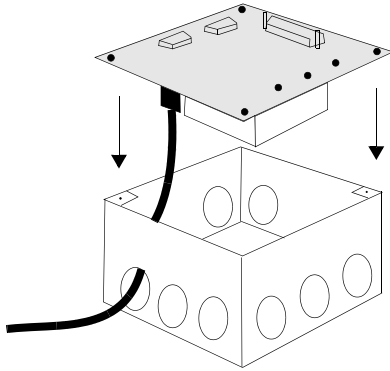

Note: Lead all wiring through the large knockout holes in the junction box, using proper bushing hardware.

Description

The 76xx/7200/7400 AC/DC Utility Interface Box (A1-63207-2) ('AC Utility Box') and the 76xx/7200/7400 DC/DC Utility Interface Box (A1-63207-3) ('DC Utility Box') consist of a printed circuit board, mounted on a cover plate, which is intended to fit within a quad utility box. These utility boxes provide power to a CiMAX-76xx, CiPro-7200, or a CiPro-7400 scanner, and allow easy connection to scanner inputs, outputs, and communications signals.

AC Input Power (A1-63207-2 only)

The terminal block TB1 on the printed circuit board is used to connect a 100-240VAC source.

TABLE 1. AC Input Power

Pin	Name	Function
1	LINE	100-240VAC Line (Brown)
2	NEUT	100-240VAC Neutral (Blue)
3	CHG	100-240VAC Ground (Green/Yellow)

DC Input Power (A1-63207-3 only)

The terminal block TB3 on the printed circuit board is used to connect an 18-36 VDC source.

Note: Do not connect Input Ground to Earth Ground. Earth Ground is used for shielding purposes.

TABLE 2. DC Input Power

Pin	Name	Function
1	DCIN+	DC Input + Voltage
2	DCIN-	DC Input Ground
3	CHG	Earth Ground

Making Connections

Scanner to Utility Interface Box

The DB25 plug on the Utility Box cover plate mates with the DB25 socket that terminates the CiPro-7200 and CiPro-7400 scanner cable.

When connecting the CiMAX-76xx scanner, you must use either (A1-63345-1) or (A1-63345-2) 8 foot cables. All power, communications, input, and output signals are present on the DB25. The A1-63345-2 cable makes no communication connections to the CiMAX-76xx scanner, so communications must be made to the scanner itself. The (A1-63345-1 rev B) and (A1-63345-2 rev C) have the additional input 3 connection, if required. Previous revisions of these cables do not.

TABLE 3. Utility Box DB25 Pin Assignments

	CiPro-7200/7400 Scanners		CiMAX-76xx Scanner	
Pin	Name	Function	Name	Function
1	CHASSIS	Chassis ground	CHASSIS	Chassis ground
2	TX232/TX485+	Main port	Host TXD	Host port
3	RX232/RX485+	Main port	Host RXD	Host port

TABLE 3. Utility Box DB25 Pin Assignments (Continued)

4	RTS232/TX485-	Main port	NC	No connect
5	CTS232/RX485-	Main port	NC	No connect
6	NC	No connect	IN3	Input 3
7	SGND	Signal ground	SGND	Signal ground
8	NO READ +	'No Read' output	OUT1	Output 1
9	VS	Presence supply	+12V	Power supply voltage
10	NC	No connect	NC	No connect
11	RIGHT+	'Right' output	OUT2	Output 2
12	RIGHT-	'Right' output	SGND	Signal ground
13	VS	Power supply	+12V	Power supply voltage
14	WRONG+	'Wrong' output	OUT3	Output 3
15	WRONG-	'Wrong' output	SGND	Signal ground
16	NC	No connect	NC	No connect
17	NC	No connect	NC	No connect
18	PS+	Presence sensor	IN1	Input 1

TABLE 3. Utility Box DB25 Pin Assignments (Continued)

19	PS-	Presence sensor	IN2	Input 2
20	RXAUX	Auxiliary port	TERMRXD	Terminal port
21	TXAUX	Auxiliary port	TERMTXD	Terminal port
22	NO READ-	'No Read' output	NC	No connect
23	CTSAUX	Auxiliary port	NC	No connect
24	RTSAUX	Auxiliary port	NC	No connect
25	SGND	Signal ground	NC	No connect

Main and Auxiliary Communications Ports

The Main DB9 socket on the cover plate is for access to the Main/Host communications port. Use a straight through 9-pin male/female cable to connect the Utility Box DB9 to a PC serial port to program the scanner and receive data.

TABLE 4. Main DB9F Pin Out

Pin	Name	Function
1	MAINRTS/TX485-	Main port (output)
2	MAINTX232/TX485+	Main port (output)
3	MAINRX232/RX485+	Main port (input)
4	MAINCTS/RX485-	Main port (input)
5	SGND	Signal ground
6,7,8,9	NC	No connect

The AUX DB9 plug on the cover plate is for access to the AUX communications port. Use a straight through 9-pin male/female cable to connect the Utility Box DB9M to an additional standard utility box, if that scanner is set up in pass through mode. The Auxiliary port is also used in CiPro-7200/7400 verifier mode.

TABLE 5. Auxiliary DB9M Pin Assignments

Pin	Name	Function
1	AUXCTS	Auxiliary port handshake (input)/Verifier Mode
2	AUXRX232	Auxiliary port RS232 (input)
3	AUXTX232	Auxiliary port RS232 (output)
4	AUXRTS	Auxiliary port handshake (output)/Verifier Mode
5	SGND	Signal ground
6,7,8,9	NC	No connect

Presence Sensor Input and Scanner Outputs

The terminal block TB2 on the printed circuit board is used to access scanner inputs and outputs, and provides +12V for Presence sensor and/or relays.

Note: Although the input and outputs are opto-isolated at the CiPro-7200/7400 scanner, they are single ended (referenced to Signal ground) on the Utility Box terminal strip.

TABLE 6. TB2 Pin Out

Pin	Name	CiPro-7200/7400 function	CiMAX-76xx function
1	GND	Signal ground	Signal ground
2	+12V	Power for presence sensor, relays	Power for presence sensor, relays
3	O1	Scanner output: No Read	Output 1: No Read Led
4	O2	Scanner output: Right	Output 2: Match Led
5	O3	Scanner output: Wrong	Output 3: No Match Led
6	GND	Signal ground	Signal ground
7	I1/P+	+ Input from presence sensor (PNP)	Input 1
8	I2/P-	- Input from presence sensor (NPN)	Input 2
9	I3	Not used	Input 3
10	GND	Signal ground	Signal ground

Setting LED Output Jumpers

The jumpers JH1, JH2, JH3 are used to connect outputs 1, 2, 3 to the LEDs respectively. These are set to OFF in the default position. The LEDs are pulled up to +12V and should be used only if no output connections are made to TB2.

Setting Presence Sensor Jumpers

The jumper header J2 is used to configure the interface box for various types of input configurations. The factory default jumper positions are for a CiMAX-76xx scanner.

- For a CiPro-7200/7400 NPN presence sensor, place one shunt over pins 1 and 2, and the other shunt over pins 3 and 4. Presence will be active when a low signal is placed on the P- input.
- For a CiPro-7200/7400 PNP presence sensor, place one shunt over pins 2 and 3, and the other shunt over pins 4 and 5. Presence will be active when a high signal is placed on the P+ input.
- For a CiMAX-76xx scanner, place one shunt over pins 2 and 3, and the other shunt over pins 6 and 7. Inputs will be active when a low signal is placed on any of the three inputs.

FIGURE 2. Presence Sensor Jumper Settings

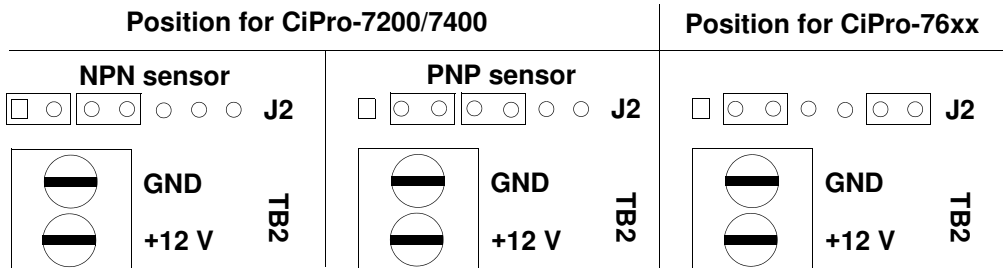

Scanner Setup

Setting Scanner Parameters

To set the CiPro-7200/7400 scanner parameters, connect a straight through type 9-pin male/female cable between the Utility Box Main DB9F and a PC serial port. Then, use the CiWINSET Windows-based program to set scanner parameters as desired.

Scanning in the CiPro-7200/7400 Verifier Code

The CiPro-7200/7400 scanner can scan in a code, which will be used as the Verifier code. The Utility Box provides an easy method to use this feature.

The procedure requires setting parameters from CiWINSET, and installing a hardware jumper.

Note: Scanning in the Verifier label saves the full scanner configuration (all parameter settings, including the scanned-in Verifier code) to the scanner's memory (EEPROM). Make sure ALL parameters have the correct values before performing this procedure.

1. Set the Multi label parameter to 'Disabled.'
2. Set the group of parameters under 'Code 1' (Type, Digit Number, etc.), for the Verifier label to be scanned.

3. Set the **Auxiliary Interface Mode** parameter to 'Disabled.'
4. Set the **Operating Mode** parameter to any value except 'Test'.

Note: It is recommended that you set this parameter to 'Automatic' (label is scanned automatically when the scan line falls on it).

5. Set the **Code Verifier** parameter to 'Enabled.'
6. Set the **Store verifier HW** parameter to 'Enabled.'
7. Jumper the RTSAUX pin to the CTSAUX pin; do this by removing any cable connected to the AUX port and jumper pins 1 and 4 of the Utility Box DB9M plug on the Standard Utility Box.
8. Scan the Verifier label. If the **Operating Mode** parameter is set to 'Automatic', simply present the label to the scanner.
9. Remove the jumper, and restore any cabling previously removed.
10. From the CiWINSET Device Control panel, press the Get button.

The scanned-in Verifier label should appear in the **Verifier Code Values** parameter.

Scanner Setup

11. Set the Store verifier HW parameter to 'Disabled.'
12. Set the Auxiliary Interface Mode parameter to the desired value.
13. Set the Operating Mode parameter to the desired value.
14. From the CiWINSET Device Control panel, press the RAM/EEPROM button until EEPROM is displayed, then press the Send button.
15. Press the RAM/EEPROM button until the desired value is displayed.

Setting Up for Master/Slave Configurations

Omni-directional reading systems with a single Master and up to 5 Slaves can be assembled using the Utility Boxes. Each scanner is connected to a multi-drop RS485 network via its Main port. This requires creating a 3-wire cable with multiple male DB9 connectors (one for each scanner), connecting to pins 2 (TX485+), 1 (TX485-), and 5 (GND). The DB9s are then plugged into each scanner Utility Box. The Presence inputs are jumpered together on all Utility Boxes and connected to the single Presence sensor. The Master scanner can communicate with the PC host over the AUX port of the Standard Utility Box (DB9M).

Setting up a Master/Slave configuration requires setting scanner multi-drop addresses and setting software parameters. Refer to the CiPro-7200/7400 User Manuals for specific information.

FIGURE 3. Master/Slave Configuration Setup

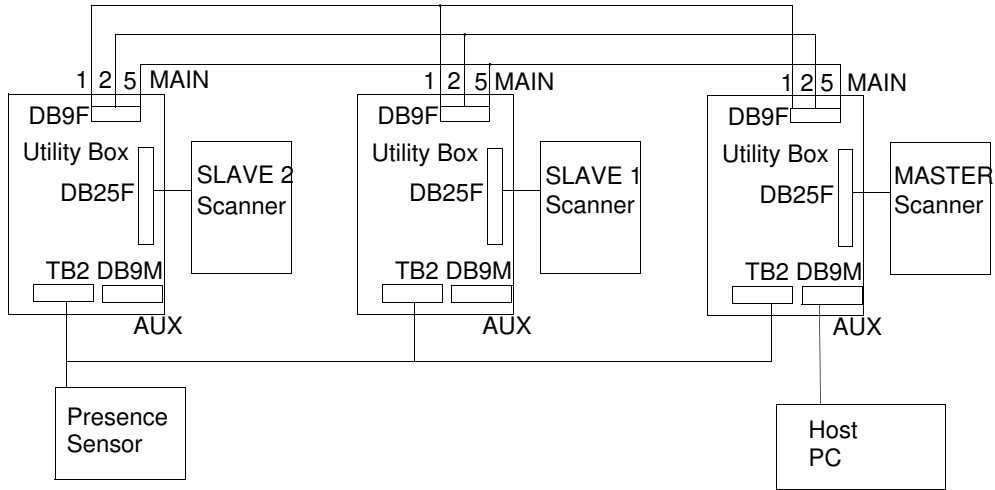

Setting Up for Pass Through Configurations

Pass through (daisy chain) mode also requires custom cabling. The first scanner in the chain is connected to the PC host via its Main port, using a straight through 9-pin male/female cable from Utility Box #1 to the PC serial port. Scanner #1 AUX port is connected to Scanner #2 Main port using a straight through cable. Scanner #2 AUX port is connected to Scanner #3 Main port using a straight through cable, and so on down the line. Each scanner has its own Presence sensor.

Wire each scanner-to-scanner cable as follows:

Scanner (n) AUX port <u>(Utility Box terminal strip)</u>		Scanner (n+1) Main port <u>(Utility Box DB9)</u>
TXAUX (DB9M Pin 3)	to	RX232 (DB9F pin 3)
RXAUX (DB9M Pin 2)	to	TX232 (DB9F pin 2)
GND (DB9M Pin 5)	to	GND (DB9F pin 5)
RTSAUX (DB9M Pin 4)	to	CTS (DB9F pin 4)
CTSAUX (DB9M Pin 1)	to	RTS (DB9F pin 1)

Scanner Setup

Setting up a Pass-through configuration requires setting software parameters. Refer to the CiPro-7200/7400 User Manuals for specific information.

FIGURE 4. Pass Through Configuration Setup

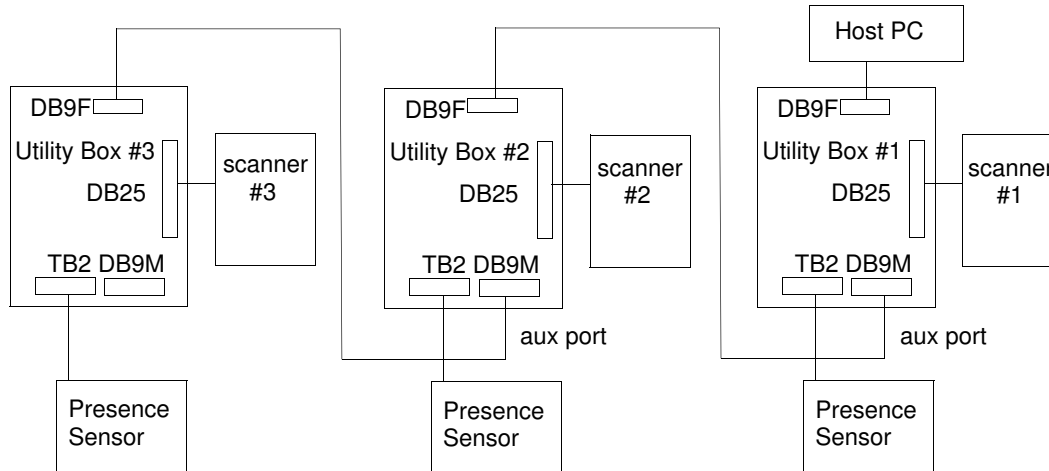

Technical Specifications

Electrical

Input power (A1-63207-2):	100-240VAC, 50-60Hz
Input power (A1-63207-3):	18-36VDC
Output voltage to scanner:	+12VDC
Output power, max:	15W
Operating temperature:	0-55°C

Inputs

One Presence Sensor input (CiPro-7200/7400). Configurable as NPN or PNP
Three inputs (CiMAX-76xx)
+12VDC provided for sensor power

Outputs

Three outputs: No Read, Match, and No Match
+12VDC provided for relay power

Communications

Full access to Main port (RS232)

Access to Auxiliary port (RS232)

Ability to scan Verifier code (CiPro-7200/7400)

Cables

A1-63345-1

CiMAX-76xx full connectivity 8 foot cable

A1-63345-2

CiMAX-76xx non communication 8 foot cable

966-0128-1

2 meters 9-pin male/female cable

Mechanical Assembly

FIGURE 5. Utility Box A1-63207-2, 3

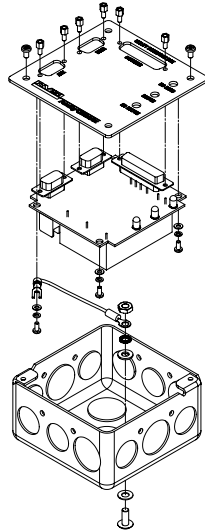

Printed Circuit Board

FIGURE 6. Printed Circuit Board

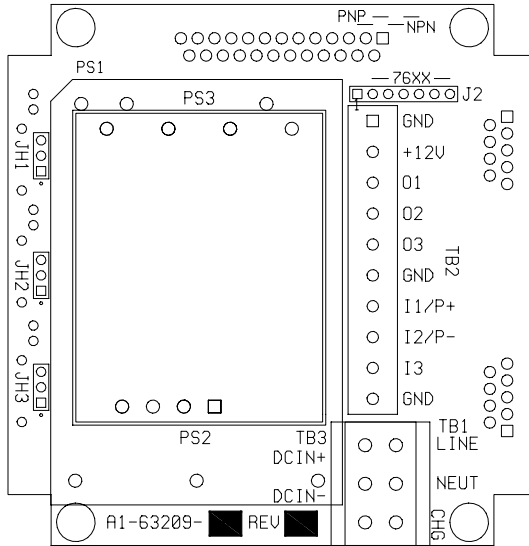

Index

A

AC Input Power 4

Auxiliary Ports 8

C

Connections

 scanner to interface box 6

D

DB9

 pin out of auxiliary 10

 pin out of main 9

DC Input Power 5

F

Features 2

M

Main Ports 8

Mechanical Assembly 23

P

Presence Sensor Input 10

S

Scanner Outputs 10

Scanning in

 CiPro-7200/7400 verifier code 14

Setting

 LED output jumpers 12

 presence sensor jumpers 12

 scanner parameters 14

Setting Up

 master/slave configurations 17

 pass through configurations 19

Specifications 21