

**TUNGSTEN™** | *T5*

# Getting Started



palmOne™

## Copyright and Trademark

© 2003-2006 palmOne, Inc. All rights reserved.

palmOne, Tungsten, the Tungsten logo, "T" (Stylized), Addit, Blazer, Graffiti, HotSync, the HotSync logo, Palm, Palm Powered, Palm OS, the Palm logo, and VersaMail are among the trademarks or registered trademarks owned by or licensed to palmOne, Inc. All other brand and product names are or may be trademarks of, and are used to identify products or services of, their respective owners.

palmOne, Inc. uses the Bluetooth wireless technology trademark under express license from Bluetooth SIG, Inc. RealPlayer is a trademark or registered trademark of RealNetworks, Inc. MPEG Layer-3 audio decoding technology is licensed from Fraunhofer IIS and Thomson.

This product includes technology owned by Microsoft Corporation and cannot be used or distributed without a license from Microsoft Licensing, GP.

## Disclaimer and Limitation of Liability

palmOne, Inc. assumes no responsibility for any damage or loss resulting from the use of this guide.

palmOne, Inc. assumes no responsibility for any loss or claims by third parties which may arise through the use of this software. palmOne, Inc. assumes no responsibility for any damage or loss caused by deletion of data as a result of malfunction, dead battery, or repairs. Be sure to make backup copies of all important data on other media to protect against data loss.

**[ ! ] IMPORTANT** Please read the End User Software License Agreement with this product before using the accompanying software program(s). Using any part of the software indicates that you accept the terms of the End User Software License Agreement.

## Software Download Available

Palm® Desktop software is supplied on a CD. If you do not have access to a CD drive for your computer, you can download Palm Desktop software from [www.palmOne.com/support/intl](http://www.palmOne.com/support/intl).

PN: 406-10116-00

v. 1.1

# Table of Contents

<b>About This Guide</b> .....	<b>vii</b>
Tips for viewing this guide.....	vii
What's in this guide? .....	viii
Sidebars.....	ix
<b>Chapter 1: Basics</b> .....	<b>1</b>
Locating the controls on your handheld .....	2
What software is on my handheld?.....	5
What's on the CD? .....	7
Using the status bar.....	10
Rotating the screen .....	11
Using the 5-way navigator .....	12
Entering information on your handheld .....	15
Using menus .....	18
Handheld do's and don'ts .....	19
Beyond the basics.....	20
<b>Chapter 2: Finding and Opening Files and Applications</b> ....	<b>21</b>
Using Favorites and Applications.....	22
Using Files .....	24
Opening files and folders from within an application .....	24
Beyond the basics.....	25
<b>Chapter 3: Moving and Managing Info Between Your Handheld and Your Computer</b> .....	<b>26</b>
Program memory and the internal drive .....	27
How can I work with information? .....	28
When would I use each method? .....	29
Synchronizing information .....	31
Using File Transfer to transfer info to your handheld .....	36

Using Drive Mode to work with info on another computer .....	40
Beyond the basics .....	43
<b>Chapter 4: Managing Your Contacts .....</b>	<b>44</b>
Adding a contact .....	45
Locating a contact on your list.....	47
Beaming a contact .....	48
Beyond the basics .....	49
<b>Chapter 5: Managing Your Calendar .....</b>	<b>50</b>
Scheduling an appointment.....	51
Checking your schedule .....	53
Setting an alarm.....	54
Beyond the basics .....	55
<b>Chapter 6: Managing Your Office Files.....</b>	<b>56</b>
How can I create and manage Office files?.....	57
Opening files from within Documents .....	58
Beyond the basics .....	59
<b>Chapter 7: Viewing Photos and Videos .....</b>	<b>60</b>
Supported file types .....	61
Viewing photos or videos .....	62
Organizing photos or videos into albums .....	64
Sharing photos and videos .....	66
Sending a photo or video using Bluetooth technology.....	67
Beyond the basics .....	68
<b>Chapter 8: Listening to Music.....</b>	<b>69</b>
Transferring MP3 files to your handheld .....	70
Transferring music from a CD to your handheld .....	72
Playing music on your handheld .....	76
Beyond the basics .....	77

<b>Chapter 9: Managing Your Tasks .....</b>	<b>78</b>
Creating a task.....	79
Organizing your tasks.....	80
Marking a task complete .....	81
Beyond the basics.....	82
<b>Chapter 10: Writing Memos.....</b>	<b>83</b>
Creating a memo .....	84
Viewing and editing a memo .....	85
Beyond the basics.....	86
<b>Chapter 11: Writing Notes in Note Pad.....</b>	<b>87</b>
Creating a note.....	88
Viewing and editing a note .....	89
Beyond the basics.....	90
<b>Chapter 12: Making Wireless Connections .....</b>	<b>91</b>
What can I do with the built-in Bluetooth wireless technology? .....	92
What types of connections can I make?.....	92
Entering basic Bluetooth settings.....	93
Setting up a phone connection.....	94
Accessing email and the web wirelessly .....	97
Setting up a connection for wireless synchronization.....	99
Beyond the basics.....	103
<b>Chapter 13: Sending and Receiving Email Messages .....</b>	<b>104</b>
Setting up an account.....	105
Getting and reading email .....	108
Sending an email message .....	109
Working with attachments .....	110
Beyond the basics.....	113

<b>Chapter 14: Sending and Receiving Text Messages .....</b>	<b>114</b>
Sending a text message .....	115
Viewing a text message .....	116
Beyond the basics .....	117
<b>Chapter 15: Browsing the Web.....</b>	<b>118</b>
Accessing a web page .....	119
Beyond the basics .....	120
<b>Chapter 16: Expanding Your Handheld.....</b>	<b>121</b>
What type of expansion cards can I use? .....	122
How can expansion cards help me?.....	122
Removing an expansion card .....	123
Inserting an expansion card.....	124
Beyond the basics .....	125
<b>Chapter 17: Customizing Your Handheld .....</b>	<b>126</b>
Setting the date and time .....	127
Preventing your handheld from turning on by accident .....	129
Changing the screen fonts .....	130
Changing the background of your screen .....	132
Correcting problems with tapping .....	133
Selecting sound settings .....	134
Changing entries in Favorites .....	135
Beyond the basics .....	136
<b>Chapter 18: Common Questions .....</b>	<b>137</b>
Beyond the basics .....	143
<b>Product Regulatory Information .....</b>	<b>144</b>
<b>Index .....</b>	<b>150</b>

# About This Guide





This guide tells you everything you need to know to start using your handheld—from the things you'll do every day, to the things that make your handheld not only useful, but fun.

## Tips for viewing this guide

Here are some helpful tips for making it easier to read and find information in this guide as you view it in Adobe Reader:

### [ ! ] Before You Begin

Complete the steps in *Read This First* in your handheld package to set up your handheld and install the software on your computer and your handheld.





- To magnify the page, click the magnifying glass , move the cursor (which is now a magnifying glass) over the page, and click repeatedly. Click Previous View (  or  depending on your version of Reader) to return to the original view.
- Click an entry in the Table of Contents or Index to go directly to that section of the guide.
- If you link to a page in the guide, to return to the page you were on before you clicked the link, click Previous View (  or  depending on your version of Reader).
- When selecting the page(s) to print, be sure to use the file page number shown at the bottom of your computer screen, not the printed page number. For example, to print the page you are reading right now, select page 7 (the file page), not page vii (the printed page).

## What's in this guide?

The info in this guide includes step-by-step instructions, links to cross-references, and sidebars.

### Step-by-step instructions

Here you'll find how-to information. Look for these cues in instructions:

 <b>Continued</b>	Cue that means the procedure continues on the next page.
 <b>Done</b>	Cue that signals the end of the procedure. You're done.
 <b>IMPORTANT</b>	A step that you must follow; otherwise, you could experience an error or even lose information.
 <b>OPTIONAL</b>	A step you might find useful.
 <b>NOTE</b>	Information that applies only in certain cases or that tells more about a procedure step.
<b>WINDOWS ONLY</b>	A procedure or text that applies to one platform only. In most cases, if you see one heading, check the following or preceding sections for the other. Sometimes, there is no Mac counterpart for a Windows procedure or text—this feature is not available to Mac users.
<b>MAC ONLY</b>	

### Links

Links appear as underlined words in sidebars and other places throughout this guide.

<b>In this chapter</b>	Links on the first page of each chapter that send you to a specific section.
<b>Beyond the basics</b>	Links on the last page of each chapter that send you to the <i>User Guide</i> on the web to learn about more things you can do with an application or feature.



## Sidebars

\* **Tip**  
To access the *User Guide*, you need to be connected to the Internet.

### [ ! ] **Before You Begin**

Things you must complete before you can do the steps described in a procedure or group of procedures.

### \* **Tip**

A suggestion on how to use a feature more fully; a shortcut; a pointer to a related feature.

### + **Did You Know?**

An interesting fact about the topic being described; may include a link to more information.

### » **Key Term**

A technical term related to the topic being described. The term may appear in this guide or only on your handheld.

### **My Handheld**

A pointer to a website where you can share info with other handheld users and learn the latest tips, tricks, and more.

### **Support**

A pointer to the web where you can find help if you experience problems with the features discussed in the chapter or with your handheld.

# Basics

## In this chapter

[Locating the controls on your handheld](#)

[What software is on my handheld?](#)

[What's on the CD?](#)

[Using the status bar](#)

[Rotating the screen](#)

[Using the 5-way navigator](#)

[Entering information on your handheld](#)

[Using menus](#)

[Handheld do's and don'ts](#)

[Beyond the basics](#)

Whether you're at work, at home, or on the go, you'll quickly understand why handhelds are also called personal digital assistants (PDAs). Like a good personal assistant, your handheld helps you keep track of your schedule, your business and personal contacts, your to-do list, your memos, even your Microsoft Office and multimedia files.

Your handheld helps you stay productive—carrying important files and documents—and connected—offering wireless access to email, text messages, and the web. And when you just want to relax and have fun, use your handheld to view digital photo and video albums, listen to music, play games, and more.



## Benefits

- Carry files and folders on an internal flash drive containing more than 160MB of storage, and work with them on the go
- Save time and stay organized
- Travel light
- Never lose important information
- Stay in touch with wireless connectivity

## Locating the controls on your handheld

### Front panel controls

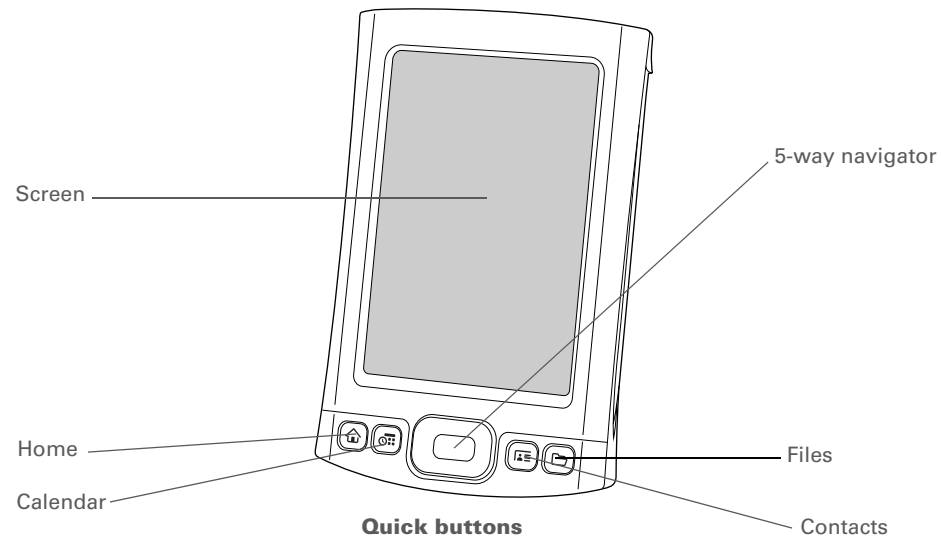

#### Screen

Displays the applications and information on your handheld. The screen is touch-sensitive.

Display the input area by tapping the Input icon  on the **status bar**. Use the input area to enter info with **Graffiti® 2 writing** or the **onscreen keyboard**.

#### 5-way navigator

Helps you move around and select info to display on the screen.

#### Quick buttons

Turn on your handheld and open Favorites, Calendar, Contacts, or Files.

» **Key Term**

**IR** Short for *infrared*. Beaming uses infrared technology to send information between two IR ports that are within a few feet of each other.

+ **Did You Know?**

Beaming lets you quickly share appointments, addresses, phone numbers, and more.

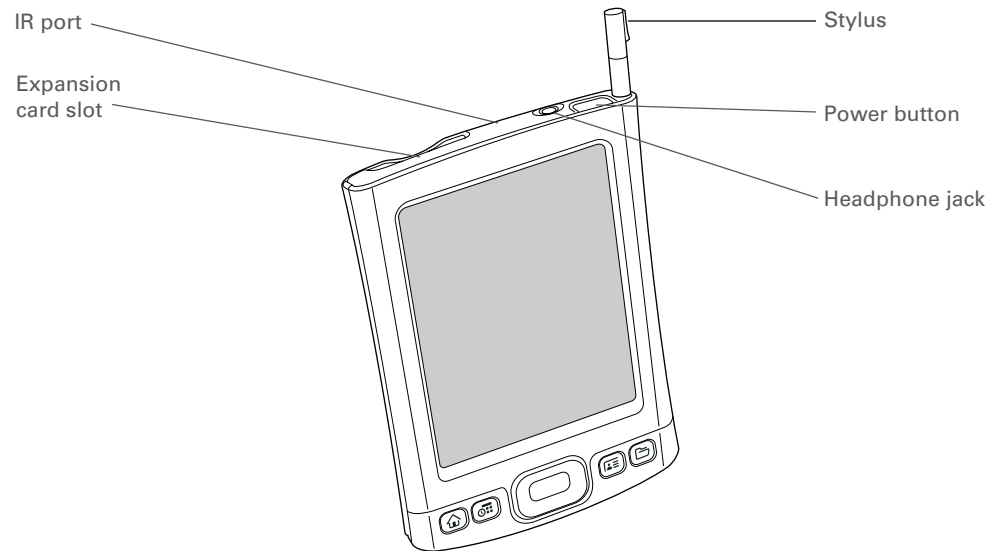
**Top and side panel controls****IR port**

**Beams information** between handhelds and other devices that have an IR port.

**Expansion card slot**

Lets you insert an expansion card (sold separately) to back up info and add memory, applications, and accessories to your handheld.

**Power button**

Turns your handheld on or off and lets you turn **Keyguard** on (if active).

**Headphone jack**

Lets you connect standard 3.5 mm stereo headphones (sold separately) to your handheld so you can listen to music and other audio applications.

**Stylus**

Lets you enter information on your handheld by writing or tapping. To use the stylus, slide it out of the slot and hold it as you would a pen or pencil. Using your fingertip instead of the stylus is OK, but don't use your fingernail, a real pen, or any other sharp object to touch the screen.

» **Key Term**  
**USB** The type of connector or cable that's commonly used to connect accessories to a computer.

## Back panel controls

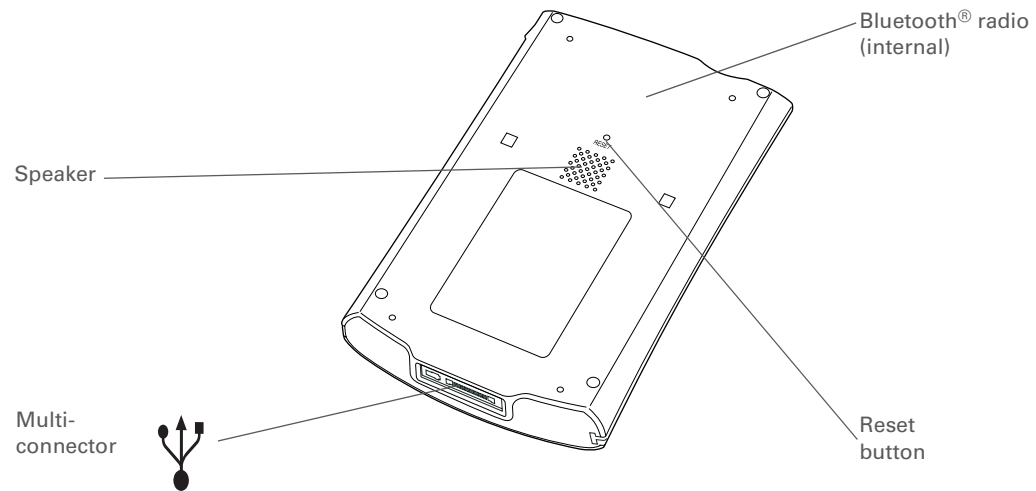

### Speaker

Lets you listen to alarms, game and system sounds, and music.

### Reset button

**Resets your handheld** if it *freezes* (stops responding).

### Multi-connector

Lets you connect a USB sync cable (included) or a cradle (sold separately) to your computer so you can **synchronize** or exchange information. Also lets you connect the AC charger to your handheld—either directly to the connector or through the USB sync cable—so you can charge it.

### Bluetooth radio (internal)











Enables your handheld to connect with other devices (sold separately) that use **Bluetooth communication**.















\* **Tip**

Can't find some of these applications? Press the Home button twice to view all applications in the [Applications View](#).

## What software is on my handheld?

Your handheld comes with many applications preinstalled and ready to use.

-  **Favorites** Customize a list of your favorite applications, files, and folders so that you can locate and open them quickly.
-  **Files** View, organize, and open files and folders on your handheld's internal flash drive.
-  **Calendar** Manage your schedule from single entries, like lunch with a friend, to repeating and extended events, like weekly meetings and holidays. Even color-code your schedule by category.
-  **Contacts** Store names and addresses, phone numbers, email and website addresses—even add a birthday alarm or a contact's photo.
-  **Documents** Create, view, and edit Microsoft Word and Excel files. View and manage PowerPoint files.
-  **palmOne™ Media** View and organize photos and videos.
-  **RealPlayer from palmOne** Carry music, create playlists, and listen to music on your handheld. This application has a companion desktop application that you can install from the CD (Windows only). Both Mac and Windows users can use RealPlayer on the handheld.
-  **Bluetooth®** Set up wireless connections to a mobile phone, network, or computer for sending and receiving information.
-  **VersaMail®** Send, receive, and manage email messages wirelessly using the built-in Bluetooth wireless technology on your handheld or by synchronizing with your Windows computer.
-  **Web** Browse your favorite sites on the web using the built-in Bluetooth technology on your handheld.

 <b>SMS</b>	Send and receive short text (SMS) messages using the built-in Bluetooth technology on your handheld.
 <b>Tasks</b>	Stay on top of your to-do list. Enter things you need to do, prioritize them, set alarms, and then monitor your deadlines.
 <b>Memos</b>	Capture information such as meeting notes, lists of books to read, movies to see, recipes, and anything else you need to write down.
 <b>Note Pad</b>	Write on the screen in your own handwriting or draw a quick sketch.
 <b>Addit™</b>	Preview, try, and buy software for your handheld (Windows only and web access required).
 <b>Calculator</b>	Do basic math calculations such as splitting restaurant bills and figuring tips.
 <b>Quick Tour</b>	Learn about your handheld and how to enter information.
 <b>Card Info</b>	View information about an expansion card seated in the expansion card slot.
 <b>Dialer</b>	Dial phone numbers directly from your handheld.
 <b>Expense</b>	Track business or travel expenses and print expense reports after you synchronize your handheld with your computer.
 <b>HotSync®</b>	Synchronize info on your handheld with the info on your computer.
 <b>Prefs</b>	Customize your handheld's sound levels, colors, security, and more.
 <b>World Clock</b>	Set the time in your home city and two other locations, and set an alarm to wake you up.
 <b>Drive Mode</b>	Connect your handheld as an external removable drive on a Mac computer or when you are a guest on a Windows computer that does not have File Transfer installed. Open files stored on your handheld on the computer, and move, copy, and manage files between your handheld and the computer.

**\* Tip**

To install extra software from the CD, insert the CD into your CD drive, and then do one of the following:

**Windows:** On the Discover Your Handheld screen, click Add software to your handheld.

**Mac:** Double-click the Essential Software folder icon.

## What's on the CD?

The Tungsten™ T5 software installation CD includes desktop software for your computer and additional software for your handheld.

The desktop software lets you use your computer to view, enter, and manage info for many of the applications on your handheld. Make sure you install the desktop software so that you can back up and save the info on your handheld onto your computer.

The additional handheld software lets you do more things with your handheld. When you set up your handheld you may install some (or all) these applications. You can install any of the applications at any time after you set up your handheld as well.

The software installation CD includes titles such as the following:

**Palm Desktop software**

View, enter, manage, and back up info for Calendar, Contacts, Tasks, Memos, and Expense on your computer. You can also view, manage, and back up info for Note Pad and Media (Expense and Media are Windows only). When you **synchronize your handheld with your computer**, this info is updated in both places. This application installs automatically during the initial CD installation process.

**NOTE** During CD installation, you can choose to synchronize your handheld with Microsoft Outlook on your computer (Windows only). If you do, information from Contacts, Calendar, Tasks, and Memos is synchronized with Outlook. Information for Expense, Note Pad, and Media is still synchronized with Palm Desktop software.

**palmOne™ Quick Install (Windows only)**

Install applications from your Windows computer to your handheld or to an expansion card that is seated in the expansion card slot for use on your handheld. This application installs automatically during the initial CD installation process.



\* **Tip**

After you install an app and discover how valuable it is, be sure to add it to **Favorites**.

+ **Did You Know?**

You can categorize applications. Some apps are automatically assigned to a category when you install them; others are assigned to the Unfiled category. All apps appear in the All category of **Applications**. Assign an application to a category in Applications by selecting Category in the App menu. Select the pick list next to the application's name; then select a category

**Send To Handheld droplet (Mac only)**

Install applications and transfer files from your Mac computer to your handheld or to an expansion card that is seated in the expansion card slot for use on your handheld. This application installs automatically during the initial CD installation process.

**palmOne™ File Transfer (Windows only)**

Install applications and transfer folders and files from your Windows computer to the **internal flash drive** on your handheld or to an expansion card. This application installs automatically during the initial CD installation process.

**Getting Started Guide**

Keep the Getting Started Guide with you and view it on your handheld. You can also install this file on your handheld to carry it with you on the go; it installs to the Palm Desktop Help automatically during the initial CD installation process;

**AudiblePlayer**

Listen to newspapers, books, public radio, language instruction, and more (Windows only; download requires Internet connection, additional fees may apply).

**Documents To Go**

Companion desktop software for the Documents application on your handheld. Lets you move or copy Microsoft Word, Excel, and PowerPoint files to the Documents folder on your handheld's internal drive, as well as create and edit files.

**RealPlayer desktop application**

Companion desktop software (Windows only) for the RealPlayer application on your handheld. Lets you convert CDs into MP3 files that you can listen to on your handheld. Both Mac and Windows users can use RealPlayer on the handheld.

**Windows Media Player/ Direct X**

Works with the palmOne Media desktop application. Direct X is required for Media to prepare videos for playback on your handheld. Windows Media Player is required for Media to play videos that have been prepared for playback on your handheld. (Windows only.)

**QuickTime**

Works with the palmOne Media desktop application. Required to prepare videos in certain formats for viewing on your handheld.

**NOTE** QuickTime is included on the CD for Windows computers only. For Mac computers, QuickTime is included in OS X.

**Java Technologies**

Access more software and functions after you download WebSphere Micro Environment to run Java (J2ME) on your handheld. (Download requires Internet connection.)

**Handmark Solitaire**

Enjoy hours of entertainment with this solitaire game.

**Adobe Reader  
for Palm OS**

View PDF files that are tailored to fit your handheld's screen.

**Power by Hand eReader**

Purchase and download eBooks from the web so you can read them when you want, where you want.

**VPN Client Software**

Create a secure wireless connection to your corporate network in order to safely send and receive email messages, access the corporate intranet, and more. (Download requires Internet connection.)

**Tutorial**

Learn to use the popular features of your handheld. The Tutorial includes a tour of your handheld and step-by-step instructions. Access it from the CD.

\* **Tip**

Use the Find dialog box to locate specific items of information in your handheld's **program memory**—for example, a name or a phone number.

+ **Did You Know?**

The System info icon shows the current time on the status bar.

## Using the status bar

The status bar at the bottom of the handheld screen gives you access to valuable tools and is accessible in all views.

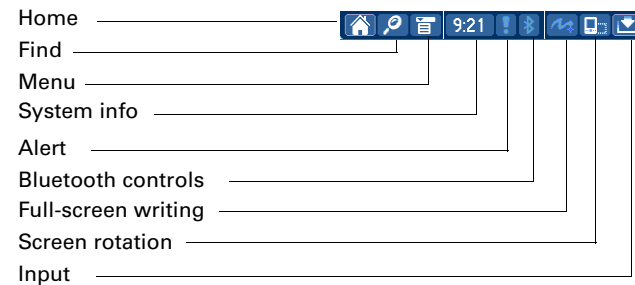

<b>Home</b>	Select once to open <b>Favorites</b> , twice to open <b>Applications</b> .
<b>Find</b>	Select to open the <b>Find dialog box</b> .
<b>Menu</b>	Select to <b>open the menu</b> for the current screen.
<b>System info</b>	Select to open the system information dialog box. The dialog box shows the date and time, available memory, and battery level, and allows you to adjust system sounds and screen brightness.
<b>Alert</b>	Select to display the <b>Reminders screen</b> .
<b>Bluetooth controls</b>	Select to display the <b>Bluetooth</b> dialog box, where Bluetooth functionality can be turned on and off and you can connect to another Bluetooth device.
<b>Full-screen writing</b>	Select to turn full-screen writing on and off.
<b>Screen rotation</b>	Select to switch between <b>landscape and portrait view</b> .
<b>Input</b>	Select to switch between showing and hiding the input area. Select and hold to display the input area selection menu.

## Rotating the screen

- + **Did You Know?**  
You can customize which way the screen rotates in landscape mode by **choosing right- or left-handed rotation.**

You can switch between landscape and portrait view by selecting Screen rotation  on the status bar. Landscape view is useful for viewing spreadsheets, email, web pages, and photos.

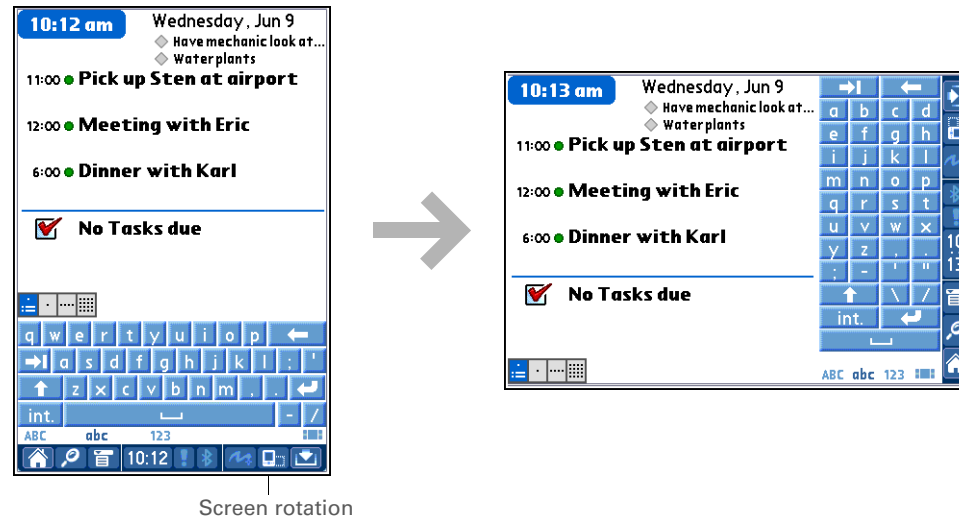

\* **Tip**  
To remove the selection highlight without making a selection, scroll to the first icon (in the upper-left corner) and then press Left on the 5-way.

## Using the 5-way navigator

The 5-way navigator lets you access information quickly with one hand and without the stylus. The 5-way does various things based on which type of screen you're on. To use the 5-way, press Up, Down, Right, Left, or Center.

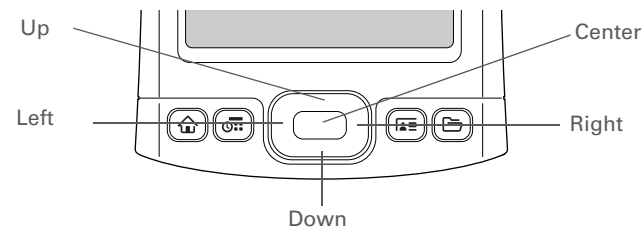

In Favorites and Applications Views—two methods for quickly **opening applications**—use the 5-way to select and open an application, folder, or file.

### Moving around in Favorites View

- |                      |  |
|----------------------|--|
| <b>Right or Left</b> | Displays the next or previous page of favorites.   |
| <b>Up or Down</b>    | Scrolls to the next favorite in the corresponding direction.   |
| <b>Center</b>        | Inserts the selection highlight. When the selection highlight is present: <ul style="list-style-type: none"> <li><b>Up or Down</b> Scrolls to the next item in the corresponding direction.</li> <li><b>Center</b> Opens the selected item.</li> </ul> |



## Moving around in Applications View

- Right or Left** Scrolls to the next or previous application category.
- Center** Inserts the selection highlight. When the selection highlight is present:
- Up, Down, Right, or Left** Scrolls to the next item in the corresponding direction.
- Center** Opens the selected item.

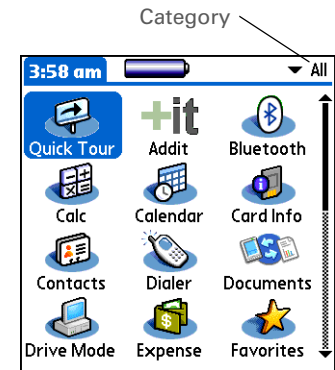

## Moving around list screens

In list screens, select and move between entries such as notes, memos, contacts, or photos.

- Up or Down** Scrolls an entire screen of entries, as long as there's nothing highlighted. Press and hold to accelerate the scrolling.
- Center** Inserts the selection highlight. When the selection highlight is present:
- Up or Down** Scrolls to the previous or next entry.
- Center** Displays the selected entry.
- Left** Removes the selection highlight.

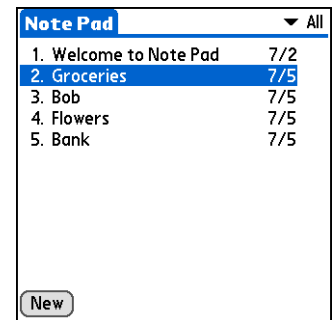

## Moving around entry screens

In entry screens, scroll within the current entry or between entries.

- Up or Down**      Scrolls within the current entry.
- Right or Left**      Scrolls to the previous or next entry (not available in Contacts).
- Center**              Returns to the list screen.

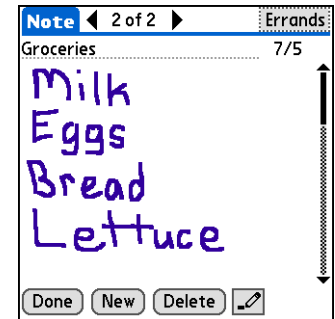

## Moving around dialog boxes

In a dialog box, use the 5-way to make selections from items such as boxes and pick lists.

- Up**                      Highlights a box or pick list.
- Center**                Checks or unchecks a box. Opens a pick list.  
When a pick list is open:
  - Up or Down**      Scrolls to the previous or next entry.
  - Center**              Selects the highlighted entry.

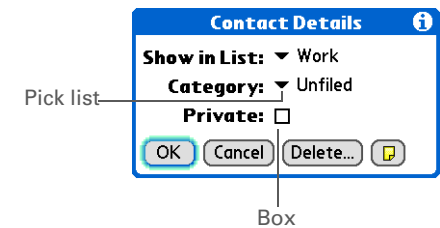

## Entering information on your handheld

There are several ways to enter information directly on your handheld. The most popular methods are using Graffiti 2 writing or using the onscreen keyboard from the **input area**. You can also **move and manage information between your handheld and a computer**.

### Learning Graffiti 2 writing

Graffiti 2 writing is a special set of letters, numbers, and symbols that you can use to write directly on the screen. With only a few minutes of practice, you can learn to use Graffiti 2 writing—and help is always only a tap away.

\* **Tip**  
Write letters on the left side of the input area and numbers on the right. Uppercase letters go in the center.

+ **Did You Know?**  
Your handheld package includes a sticker that shows the most common Graffiti 2 characters.

\* **Tip**  
Display the Graffiti 2 help screens at any time. Just draw a single stroke from the bottom of the input area to the top of your handheld's screen.

1

**Go to Favorites** and select Quick Tour .

2

Select Graffiti 2, and then navigate through the screens to learn Graffiti 2 writing.

↓ Done





» **Key Term**  
**Entry** A piece of information entered in an application such as a contact in Contacts or an appointment in Calendar.

\* **Tip**  
You can enter text whenever you see a blinking cursor on the screen.

## Using the onscreen keyboard

You can use the onscreen keyboard in any application where you need to enter text, numbers, or symbols on your handheld.

**1**

Open an entry:

- a. **Open an application.**
- b. Select an entry or tap New.

**2**

Select Input  on the status bar to open the input area.

**3**

Tap abc or 123 to open the alphabetic or numeric keyboard, respectively.

↳ **Continued**

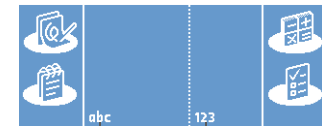

Tap to open keyboards

4

[ & ] OPTIONAL Select from among four different keyboards.

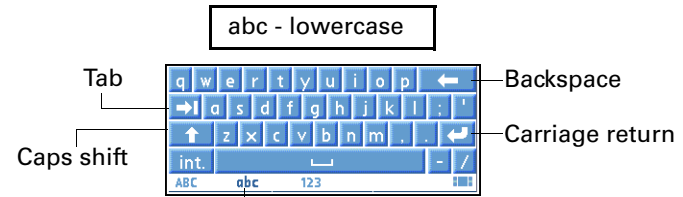

Tap here to display lowercase keyboard

ABC - uppercase



Tap here to display uppercase keyboard

123 - numeric



Tap here to display numeric keyboard

int. - international



Tap here to display international keyboard

Done

## Using menus

Menus let you access additional commands and settings. They are easy to use, and once you master them in one application, you know how to use them in all your applications.

\* **Tip**

You can also open the handheld menus by tapping the application title in the upper-left corner of the screen, or by selecting the Menu icon from the input area if it is displayed.

When the menus are open, you can **use the 5-way navigator** to select menus and menu items.

<b>1</b>	<b><u>Open an application.</u></b>
<b>2</b>	Select Menu  on the status bar.
<b>3</b>	Select a menu, and then select a menu item.  ↓ Done

## Handheld do's and don'ts

To protect your handheld from damage and ensure reliable performance, follow these guidelines.

### Handheld do's

- Use the flip cover that came with your handheld.
- Use only the stylus to tap the screen—no pens, pencils, paper clips, or other sharp objects.
- Use only the supplied AC charger to charge your handheld.
- **Keep the battery charged.**
- Keep the screen free of dust (or anything else that could make it dirty).
- For general cleaning, use a soft, damp cloth. If the screen becomes dirty, use a soft cloth moistened with a diluted window-cleaning solution.
- Use only 3.5 mm stereo headphones in your handheld's headphone jack.
- Be sure to **get rid of any static electricity buildup** before you connect your handheld to any cable or accessory.

### Handheld don'ts

- Do not drop, bang, or otherwise cause a strong impact to your handheld.
- Do not carry your handheld in your back pocket; you might sit on it by mistake.
- Do not let your handheld get wet; don't even leave it in a damp location.
- Do not expose your handheld to very hot or cold temperatures, including placing it near a heater, leaving it in the trunk of a car, or setting it by a window in direct sunlight.

## Beyond the basics

Click the link to the left to go to the *User Guide* on the web and learn about these related topics:

### User Guide

For everything you need to know about your handheld—all that's in this guide, and much more—go to [www.palmOne.com/tungstent5-userguide](http://www.palmOne.com/tungstent5-userguide).

### My Handheld

Make your handheld uniquely yours. For great tips, software, accessories, and more, visit [www.palmOne.com/mytungstent5](http://www.palmOne.com/mytungstent5).

### Support

If you're having problems with your handheld, go to [www.palmOne.com/support/tungstent5](http://www.palmOne.com/support/tungstent5).

Entering Information	Entering information with Graffiti 2 characters
Moving Around	<ul style="list-style-type: none"> <li>• Working with the Favorites and Applications, finding information, and moving around in applications</li> <li>• Using Files to locate files and folders on your handheld</li> </ul>
Installing and Removing	<ul style="list-style-type: none"> <li>• Adding applications to your handheld</li> <li>• Deleting applications from your handheld</li> <li>• Viewing application information</li> </ul>
Categories	Organizing your applications and information by filing them into categories
Privacy	Keeping information private by turning on security options
Sharing	<ul style="list-style-type: none"> <li>• Beaming information and applications to other Palm Powered™ devices</li> <li>• Sending information and applications to other Bluetooth devices by using Bluetooth technology on your handheld</li> </ul>
Maintaining	Caring for your handheld

# Finding and Opening Files and Applications

## In this chapter

[Using Favorites and Applications](#)

[Using Files](#)

[Opening files and folders from within an application](#)

[Beyond the basics](#)

Part of what makes your handheld so useful is how quickly and easily you can access its built-in features—as well as the information you store on it. Your handheld offers a number of options for accessing files, folders, and applications, so you can choose the one that's right for you in any situation.



## Benefits

- Quickly access the application you want or the info you need
- Choose the method that's right for you
- Customize your handheld to have one-touch access to the applications or features you select

## Using Favorites and Applications

Your handheld lets you display two views to quickly see and open the files and applications you use most. Favorites lets you create a list of the items you want to quickly access, while Applications displays all applications on your handheld.

### Using Favorites

The Favorites View contains up to 32 items and can include applications, specific files, and folders—even links to the web. Certain items are included in Favorites by default, but you can **customize the list** to contain any items you want.

To access an item from Favorites, press Home  and select from the list. Use the 5-way navigator or tap the buttons in the upper-right corner of the screen to move to another page of favorites.

\* **Tip**  
Press Home once to open Favorites; press Home twice to open Applications. Switch between Favorites and Applications by pressing Home.

+ **Did You Know?**  
You can **use a favorite photo as the background** for your Favorites or Applications View.

\* **Tip**  
**Customize Favorites** to display folders—for example, a project folder that you access often. Select the folder to view all files and subfolders (if there are any) in it.

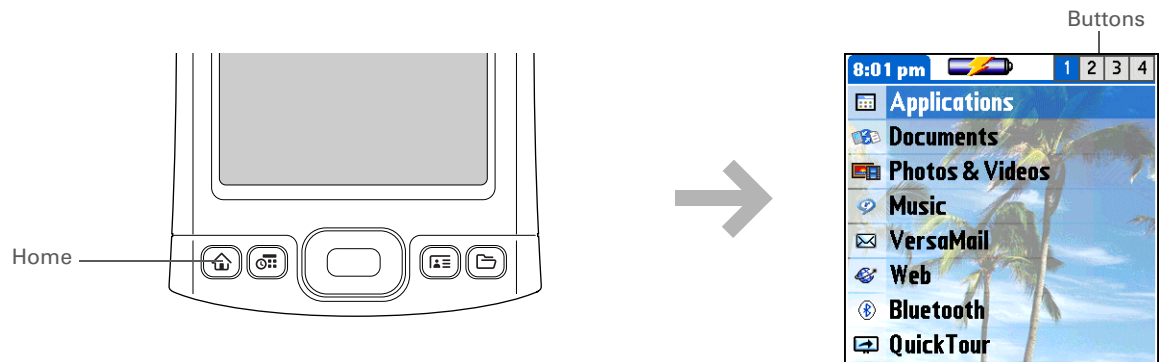

## Using Applications

The Applications View shows all of the applications on your handheld. Use the category pick list in the upper-right corner of the screen to view applications by category or to see all applications.

To access an item from Applications, press Home  twice and select an icon.

- \* **Tip**  
You can **customize the Home button** to open Applications with one press and Favorites with two.
- + **Did You Know?**  
You can also open applications using the **quick buttons** on the front of your handheld.
- \* **Tip**  
Press Center on the 5-way to scroll through application categories.

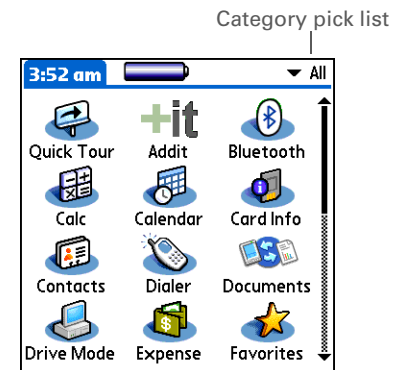
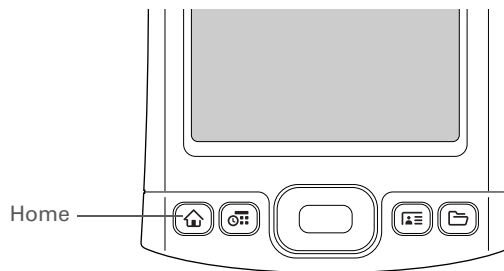



## Using Files



\* **Tip**  
Sort your Files display by file type, file name, date, or size.

+ **Did You Know?**  
If you select a file from within Files, it automatically opens in the correct application on your handheld. If there is no application for that file, a beep alert sounds.

\* **Tip**  
If you have an expansion card (sold separately) inserted in your handheld's expansion slot, select the card icon in Files to view the contents of the card.

\* **Tip**  
Tap and hold the stylus on a file or folder to open a menu of actions you can do with that item—copy, delete, and so on.

The Files application enables you to easily open, view, and move among the files and folders on your handheld's **internal flash drive** or on an expansion card inserted into your handheld's expansion slot.

To open Files, press the Files button  on the front of your handheld. Select a file or folder to open it. Select the Folder Up icon  to move up one level of folders.

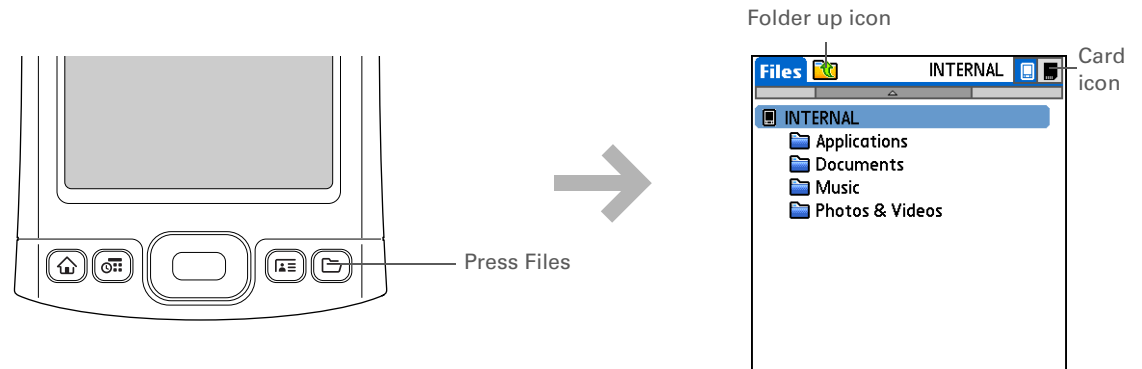

**NOTE** Files contains four folders that always appear at the top of the folder list: Applications, Documents, Music, and Photos & Videos. Place your applications and files in the correct folder so that you can easily locate them.

## Opening files and folders from within an application

In certain applications—for example, Documents, palmOne Media, and RealPlayer from palmOne—you can open a file or folder directly from within the application. The application automatically displays files located in the appropriate folder on your handheld's internal drive—for example, the Music folder for RealOne—but you can browse for files located elsewhere on the drive. See the application chapters for information on opening files.

## Beyond the basics

Click the link to the left to go to the *User Guide* on the web and learn about these related topics:

### Moving Around

- Reassigning, renaming, and removing favorites
- Rearranging favorites in Favorites View
- Sorting and customizing the Files display
- Accessing recent files or folders from within Files
- Using commands to delete, beam, send, and copy from within Files
- Saving files using Files

### Customizing

Reassigning applications or features for your quick buttons

### User Guide

For everything you need to know about your handheld—all that's in this guide, and much more—go to [www.palmOne.com/tungstent5-userguide](http://www.palmOne.com/tungstent5-userguide).

### My Handheld

Make your handheld uniquely yours. For great tips, software, accessories, and more, visit [www.palmOne.com/mytungstent5](http://www.palmOne.com/mytungstent5).

### Support

If you're having problems with your handheld, go to [www.palmOne.com/support/tungstent5](http://www.palmOne.com/support/tungstent5).

# Moving and Managing Info Between Your Handheld and Your Computer

In this chapter

[Program memory and the internal drive](#)

[How can I work with information?](#)

[When would I use each method?](#)

[Synchronizing information](#)

[Using Quick Install and the Send To Handheld droplet](#)

[Using File Transfer to transfer info to your handheld](#)

[Using Drive Mode to work with info on another computer](#)

[Beyond the basics](#)

You can do a lot with your handheld on its own: enter or look up a contact, write a memo, keep track of your appointments. But you can do much more when you share, manage, and work with information between your handheld and a computer.

Your handheld includes a large internal drive so that you can carry more of your documents, folders, photos, and music with you. View, create, or work on files on your handheld, then copy the updated version back to your computer. Or use your handheld at any computer to access and work on your files.



## Benefits

- Quickly enter and update information on your handheld and your computer
- Install and work with applications, files, and folders on your handheld
- Increase productivity by having the files you need wherever you go
- Protect your information by quickly backing up and saving files and folders to your computer

**+ Did You Know?**

The internal drive saves information on your handheld permanently. Even if the battery drains completely, none of your information is lost. Simply recharge to access the information again.

## Program memory and the internal drive

Your handheld contains two types of storage: program memory and the internal flash drive.

**Program memory** Your handheld includes 55MB of program memory for Palm OS® applications and information. If an app or information is located in your handheld's program memory, you can view and access that information, as well as information associated with that application that is stored on the internal drive. You cannot, however, view the info directly using **Files** or **palmOne™ File Transfer**.

Information in the program memory is updated during synchronization. For example, if you enter contact information on your computer, you can synchronize to update the info in Contacts on your handheld, and any future updates to the info are included in synchronization.

**Internal flash drive** The 160MB internal drive works similarly to any other removable external drive. You can store any type of file, folder, or application on this drive on your handheld. View and access the contents of the internal drive using the Files application on your handheld, or view the contents using File Transfer (Windows) or **Drive Mode** (Mac) on your computer. You can manage items on the internal drive in various ways: copying, moving, deleting, renaming, and so on using File Transfer (Windows) or Drive Mode (Mac), or Files on your handheld. You can also use File Transfer to **save the contents of the internal drive** to your Windows computer.

Another method of storage that you may already be familiar with is an **expansion card**. You can view and access files or folders on an expansion card using the Files application on your handheld, and manage your files on a card using File Transfer or Drive Mode.

You can also access the files on the internal drive or on an expansion card by opening the corresponding application and browsing to the file.

- + **Did You Know?** Photos and videos transferred using Media are saved in the Photos & Videos folder on your handheld's internal drive, but updates are included when you synchronize.
  
- + **Did You Know?** Keeping files in their native format is useful. On your handheld you can work with many of these native files, such as Word, Excel, PowerPoint, and JPG files. You can also use File Transfer or **Drive Mode** to carry native files, even files that you cannot open on your handheld, to work with on a different computer.

## How can I work with information?

There are two main methods for moving and managing information between your handheld and a computer. These methods are discussed in detail in this chapter.

**Synchronization** Synchronization updates and backs up information between your handheld's program memory and your computer. Information entered in one place is automatically updated in the other, and info in your handheld's program memory is backed up on your computer.

Use Palm® Desktop software or Microsoft Outlook to enter information on your computer in applications such as Calendar, Contacts, Tasks, and Memos. The info is transferred to the corresponding handheld application when you synchronize. Information entered in these applications on the handheld is likewise synchronized with the application in the desktop software.

On Windows computers, Palm Desktop software includes palmOne™ Media, which you can use to transfer photos and videos to your handheld. On Windows computers, Palm Desktop also includes palmOne Quick Install, which installs applications (PRC or PDB) for use on your handheld when you synchronize.

**NOTE** On Mac computers, use the Send To Handheld droplet to transfer photos and videos and install applications on your handheld when you synchronize.

When you transfer a file to your handheld through synchronization, the file, such as a video, may be converted for best use on (optimized for) your handheld.

**File Transfer (Windows only)** Use File Transfer to transfer files and folders or install applications to your handheld's large internal flash drive. To open a file on the internal drive, use Files and select the file, or open the appropriate application and browse to the file.

File Transfer provides a live window to your handheld's internal drive and copies or moves the items you select instantly; you do not need to synchronize. Files remain in their native format and are not optimized for use on your handheld. Unlike the program memory, your handheld's internal drive is not automatically backed up during synchronization—but you can use File Transfer to **save the contents of the internal drive** to your computer.

**NOTE** On Mac computers, use Drive Mode to transfer info to your handheld's internal drive.

## When would I use each method?

The method you use to move info onto your handheld depends on the type of info it is. Here are the methods to use with the most common information types.

### + Did You Know?

When you transfer files using synchronization, the files are always placed in the corresponding folder on your handheld—for example, the Music folder for MP3 files or the Documents folder for Office files.

If you transfer files using File Transfer, save them to the corresponding folder so you can easily locate them—or copy or create your own folder structure to organize your project files any way you like.



**Information in Contacts, Calendar, Tasks, Memos, Notes (Windows only: Expense, VersaMail® application)** Use Palm Desktop or Outlook (Windows) to enter information on to your computer. Synchronize to transfer the new or updated information on your computer to your handheld.



**Applications (PRC or PDB file)** Use Quick Install from within Palm Desktop (Windows) or drag the application to the Send To Handheld droplet icon on your desktop (Mac), and then synchronize to install the application to your handheld.

## \* Tip

You can choose to synchronize a Word, Excel, or PowerPoint file, even if you copied it using File Transfer. See the Documents To Go application on your computer for information.



## + Did You Know?

When you transfer photos and videos using the desktop Media application, the files may be converted for viewing on your handheld. File Transfer does not convert files, so you may not be able to view the photos or videos on your handheld.



**Word documents, Excel spreadsheets, PowerPoint presentations** Method 1: Use the Documents To Go application on your computer. Synchronize to install the files to the Documents folder on your handheld's internal drive.

Method 2: Use File Transfer (Windows) or Drive Mode (Mac) to copy an entire folder structure of files to your handheld's internal drive. This allows you to keep all of your project folders together with the same structure you've created on your computer.

**Photos and videos** Method 1: Use the desktop Media application from within Palm Desktop (Windows) or drag the files to the Send To Handheld droplet icon on your desktop (Mac). Synchronize to install the files to the Photos & Videos folder on your handheld's internal drive.

Method 2: Use File Transfer (Windows) or Drive Mode (Mac) to copy an entire folder structure of photos and videos to your handheld's internal drive. This allows you to keep all of your vacation photos and videos together with the same structure you've created on your computer.

**Music (MP3) files** Method 1: Use the **RealPlayer desktop application** (Windows) to transfer the files to the Music folder on your handheld's internal drive.

Method 2: Use File Transfer (Windows) or Drive Mode (Mac) to copy an entire folder structure of music files to your handheld's internal drive. This allows you to keep all of the songs you copied from a CD together with the same structure you've created on your computer.

\* **Tip**

You can **synchronize your handheld with your computer wirelessly** using the built-in Bluetooth® wireless technology on your handheld.

+ **Did You Know?**

Everybody in your family can synchronize their handheld with the same copy of Palm Desktop software. Just make sure that each handheld has its own username; Palm Desktop software reads the username and recognizes the handheld during synchronization.

## Synchronizing information

Synchronizing means that information that is entered or updated in one place (your handheld or your computer) is automatically updated in the other. No need to enter information twice.

**[ ! ] IMPORTANT** Be sure to synchronize the info in your handheld's program memory at least once a day so that you always have an up-to-date backup copy of this info on your computer.

## Entering information using desktop software

Use Palm Desktop or Outlook to enter information on your computer. When you synchronize, the information is updated in your handheld's program memory.

If you use the default settings, information from all the following applications is transferred each time you synchronize your handheld with your computer:



Calendar



Contacts



Documents



Expense



Media



Memos



Note Pad



Tasks



VersaMail

If you choose to synchronize with Outlook, info from Contacts, Calendar, Tasks, and Memos is synchronized with Outlook. You can also set up the VersaMail application to synchronize with Outlook. Other info, such as photos and notes, is synchronized with Palm Desktop software.

**[ ! ] IMPORTANT** Applications, files, and folders moved to your handheld's internal drive with File Transfer are not automatically backed up during synchronization. Use File Transfer to copy or move the updated files and folders to your computer, or to **back up the contents of your handheld's entire internal drive to your computer.**



\* **Tip**  
The Palm Desktop online Help has lots of info about how to use Palm Desktop software, File Transfer, and other desktop applications such as Media. Open the Help menu and select Palm Desktop Help.

### WINDOWS ONLY

Double-click the Palm Desktop icon on your computer desktop, and then click the icons in the launch bar to access the various applications.

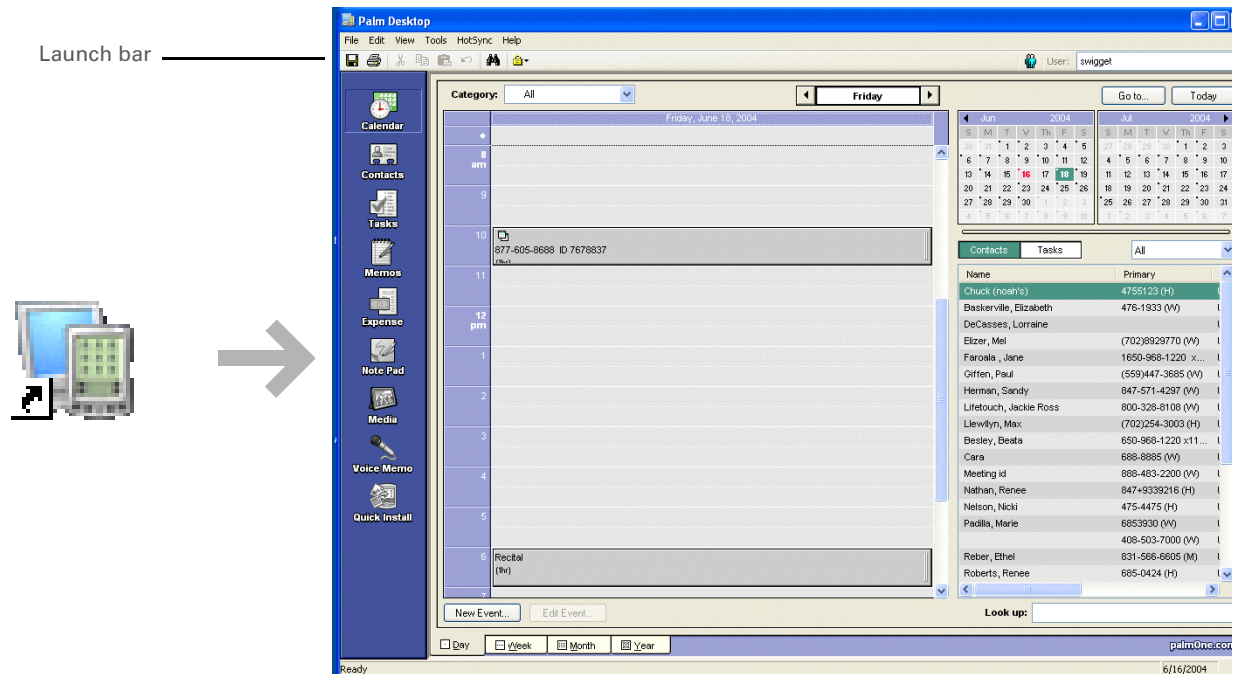

**MAC ONLY**

Double-click the Palm Desktop icon in the Palm folder on your computer, and then click the icons in the launch bar to access the various applications.

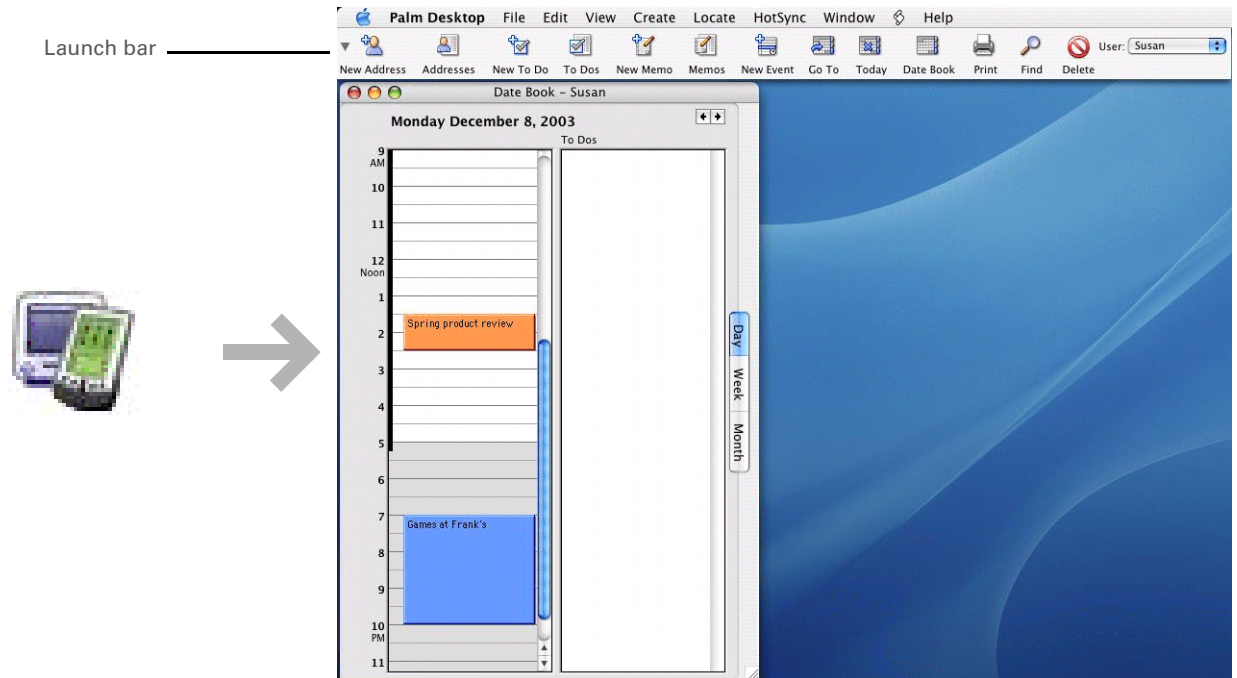

## How to synchronize

» **Key Term**  
**HotSync®** Technology that allows you to synchronize the information in your handheld's program memory with the information on your computer.

\* **Tip**  
If the Select User dialog box appears during synchronization, select the username whose information you want to synchronize, and then click OK.

\* **Tip**  
If you need help with synchronizing, see [What do I do if I can't synchronize with my computer?](#)

**1**

Connect the USB sync cable to the USB port on the rear of your computer, and then insert the other end into your handheld.

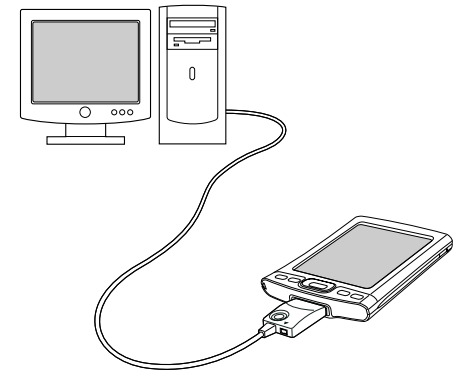
**2**

Synchronize your handheld with your computer:

- a. Press the HotSync button on the USB sync cable.
- b. When synchronization is complete, a message appears at the top of your handheld screen, and you can disconnect your handheld from the connector.

↓ Done

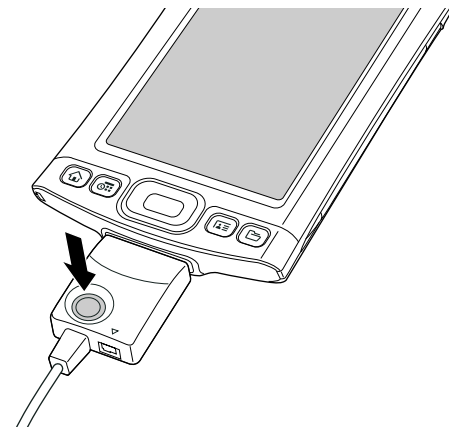

## Using Quick Install and the Send To Handheld droplet

Use Quick Install (Windows) or the Send To Handheld droplet to install applications on your handheld. The applications are stored in program memory and are optimized for use on the handheld.

### Using Quick Install

#### WINDOWS ONLY

\* **Tip**  
A confirmation dialog box shows whether the items will be copied to your handheld or to an expansion card. You can choose which handheld will receive the items by selecting the username in the User drop-down box in the upper-right corner.

+ **Did You Know?**  
You can move multiple applications into the Quick Install window to have them ready for installation the next time you synchronize.

<b>1</b>	<b><u>Open Palm Desktop software.</u></b>
<b>2</b>	<p>Copy the application:</p> <ol style="list-style-type: none"><li>Click the Quick Install icon in the launch bar at the left of the window.</li><li>Drag and drop the application onto the Quick Install window.</li><li>When the confirmation dialog box appears, confirm your username, the application name, and the destination, and then click OK.</li></ol>
<b>3</b>	<b><u>Synchronize to install the file to your handheld.</u></b>  ↓ Done



## Using the Send To Handheld droplet

### MAC ONLY

#### \* Tip

In Mac OS X, you can make the Send To Handheld droplet a permanent part of your desktop by dragging the droplet to the Dock. Then simply drag photos, and other files you want to transfer to your handheld, onto the Dock.

**1**

Select the applications or files you want to install:

- a. Drag and drop the applications or files onto the Send To Handheld droplet in the Palm folder.
- b. In the Send To Handheld dialog box, select your username and click OK.

**2**

**Synchronize your computer with your handheld.**

↓ Done

## Using File Transfer to transfer info to your handheld

**NOTE** On a Mac computer, use **Drive Mode** to move files to your handheld's internal drive.

### WINDOWS ONLY

On a Windows computer, File Transfer provides a live window to your handheld's large internal drive. Use File Transfer to copy, move, and manage files and folders on your handheld. File Transfer copies and moves items instantly; you do not need to synchronize. With File Transfer you can also work on your handheld even while transferring files.

Using File Transfer, quickly move and carry large amounts of your important Office files, photos, music, videos, and other files on your handheld. Access and edit information on your handheld or from any other computer that supports removable external drives.

\* **Tip**  
Use File Transfer to back up the contents of your handheld's internal drive to your main computer. In the File Transfer window, right-click the folder next to the handheld icon, and then click Save to PC.

[ ! ] **IMPORTANT** Applications, files, and folders moved to your handheld's internal drive with File Transfer are not automatically backed up during synchronization. Use File Transfer to copy or move the updated files and folders to your computer, or to back up the contents your handheld's entire internal drive to your computer.

# 1

Open File Transfer:

- a. Connect the USB sync cable to the USB port on the rear of your computer, and then insert the other end into your handheld.
- b. Double-click the File Transfer icon  on your computer desktop to open the File Transfer window. The File Transfer window opens to display the contents of the internal drive on your handheld; if an expansion card is inserted into your handheld's expansion slot, the window displays the card's contents as well.

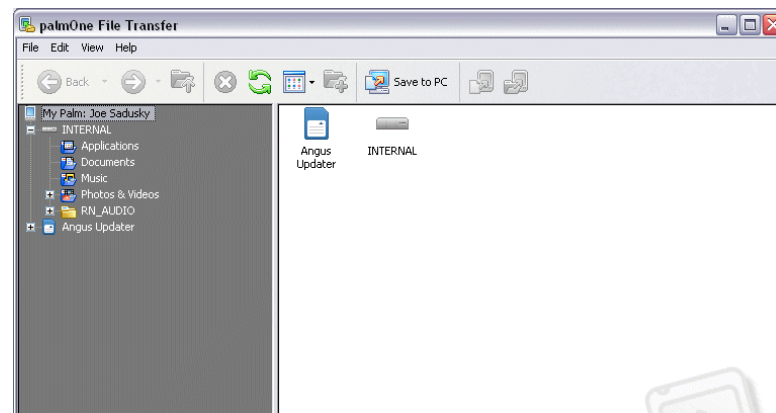

**NOTE** If your handheld is not connected to your computer or is unavailable, an alert message appears.

➤ **Continued**

**\* Tip**

In the File Transfer window you can also **manage folders** by creating, renaming, moving, and deleting folders, as well as changing folder attributes.

**2**

Drag, copy, or move files, folders, or applications from the desktop into the File Transfer window to the location you want on your handheld's internal drive.

**NOTE** If you use File Transfer to install an application in the Applications folder on your internal drive—and if app is designed to run from that location—you can run the application on your handheld.

**3**

Work with files on your handheld:

- a. Press the Files button .
- b. Browse to find the file you want.
- c. Select the file to open it.

**NOTE** If there is no application for the file, a beep alert sounds.

 **Continued**

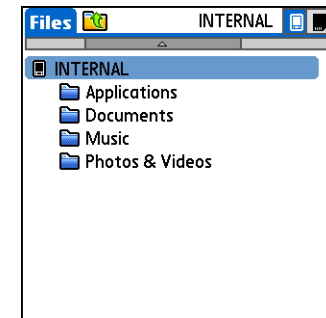

**4**

Access or move files from your handheld to a computer that has File Transfer installed:

- a. Connect the USB sync cable to the USB port on the rear of the computer, and then insert the other end into your handheld.
- b. Double-click the File Transfer icon  on the computer desktop to open the File Transfer window. The File Transfer window opens to display the contents of the internal drive on your handheld.
- c. Access, move, or copy files from the File Transfer window to the computer desktop.

↓ Done



## Using Drive Mode to work with info on another computer

\* **Tip**  
When you use File Transfer or Drive Mode, remember to bring your USB sync cable with you, so you can connect to other computers.

On a Mac computer, use Drive Mode to move files between a computer and your handheld's internal drive.

If you are at a Windows computer that doesn't have File Transfer installed—a computer at a hotel or your friend's house, for example—use Drive Mode to open, move, or copy files on your handheld. With Drive Mode, your handheld connects to your computer like an external removable drive such as a CD drive.

The computer must support external removable drives in order for you to use Drive Mode with the computer. Most current operating systems such as Windows 2000, Windows XP, and Mac OS X support external removable drives.

**NOTE** While you're using Drive Mode, you cannot use any other feature of your handheld.

**1**

Turn on Drive Mode:

- a. **Go to Applications** and select Drive Mode .
- b. Select Turn drive mode on.

↘ Continued

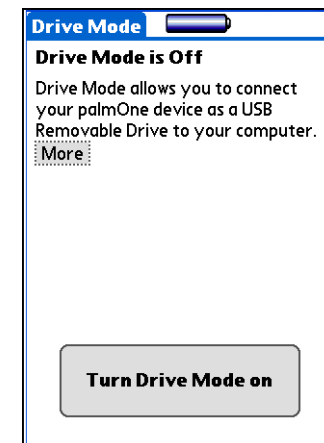

**2**

Prepare your handheld and your computer:

- a. Connect the USB sync cable to the USB port on the rear of the computer, and then insert the other end into your handheld.
- b. Connect the AC charger cable to the USB sync cable, and then plug it in to a power outlet.

**3**

Open My Computer or Windows Explorer on a Windows computer, or Finder on a Mac computer. Look for the icon representing your handheld in the list of available drives on the computer. If there is an expansion card inserted in your handheld's expansion slot, it appears as a drive also.

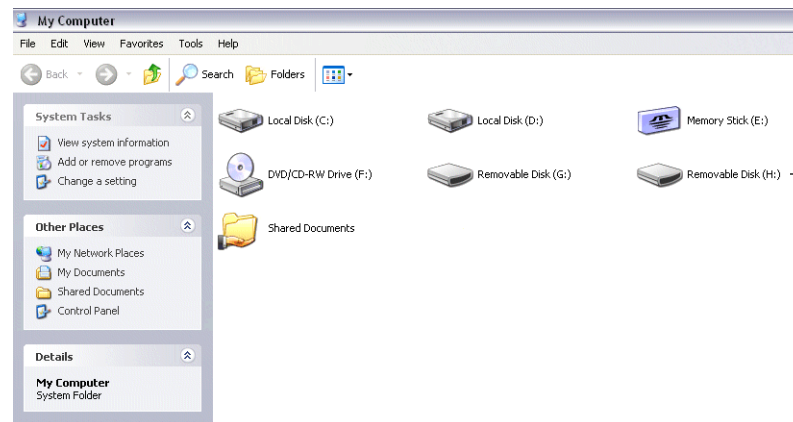

Handheld appears as removable drive

↙ Continued

**\* Tip**

If you are working with an expansion card, you must eject the handheld from the computer before removing the card in order to avoid losing info on the card.

**4**

Work with the files on your handheld as you would on any other external removable drive.

**5**

When you are finished working with Drive Mode, do the following:

**[ ! ] IMPORTANT** To avoid losing any information that was transferred, be sure to follow these steps to disconnect from Drive Mode.

- a. Eject the handheld from your Windows computer by selecting the Safely Remove Hardware icon  in the taskbar in the lower-right corner of your computer screen. On a Mac computer, select the Eject command from the File menu or drag the drive icon to the Eject icon on the Dock.
- b. Select Turn drive mode off on your handheld screen, and then select Yes.

 Done

**User Guide**

For everything you need to know about your handheld—all that's in this guide, and much more—go to [www.palmOne.com/tungstent5-userguide](http://www.palmOne.com/tungstent5-userguide).

**My Handheld**

Make your handheld uniquely yours. For great tips, software, accessories, and more, visit [www.palmOne.com/mytungstent5](http://www.palmOne.com/mytungstent5).

**Support**

If you're having problems with moving information or with anything else on your handheld, go to [www.palmOne.com/support/tungstent5](http://www.palmOne.com/support/tungstent5).

## Beyond the basics

Click the link to the left to go to the *User Guide* on the web and learn about these related topics:

- |               |   |
|---------------|---|
| Moving Around | <ul style="list-style-type: none"><li>• Using File Transfer with security preferences you set for your handheld</li><li>• Creating, copying, pasting, deleting, and renaming files in File Transfer</li><li>• Changing folder attributes in File Transfer</li></ul>   |
| Synchronizing | <ul style="list-style-type: none"><li>• Synchronizing your handheld with Microsoft Outlook on your computer</li><li>• Synchronizing wirelessly using Bluetooth technology on your handheld</li><li>• Using your company's network to synchronize information</li><li>• Choosing whether or not to synchronize information for a specific application</li><li>• Switching back to the cable if you have been synchronizing information using Bluetooth technology</li><li>• Receiving information on your handheld from an outside source, such as a file containing your company's phone list</li></ul> |

# Managing Your Contacts

## In this chapter

[Adding a contact](#)

[Locating a contact on your list](#)

[Beaming a contact](#)

[Beyond the basics](#)

Say goodbye to a paper address book that you need to update manually every time someone moves, changes their email address, or gets a new work extension. With Contacts, not only is it easy to enter information such as names, addresses, and phone numbers, but it is just as quick to view, update, and organize contact information.

You can easily share info with other handhelds and dial phone numbers or send messages directly from a contact entry using your handheld's built-in Bluetooth<sup>®</sup> wireless technology and a compatible mobile phone, or by beaming. You can even add photos of your loved ones directly to their contact information screen.



## Benefits

- Carry all your business and personal contact information in your hand
- Keep track of who is who
- Keep in touch

## Adding a contact

### \* Tip

If the first character you enter in the Last Name or Company field is an asterisk (\*) or another symbol, that contact always appears at the top of the Contacts list. That's useful for an entry like "If Found Call [your phone number]."

### + Did You Know?

You can also enter one or more contacts on your desktop computer, and then copy them to your handheld by [synchronizing](#).

1

Press the Contacts  button.

2

Add your contact information:

a. Select New.

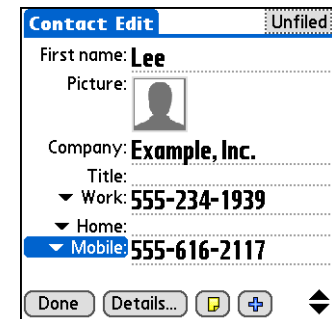
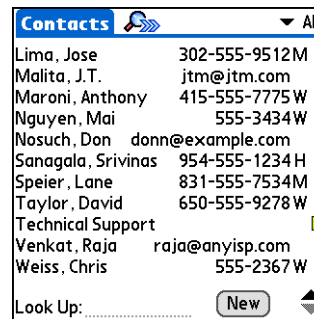

b. Tap each field in which you want to enter information, and enter it. Tap the scroll arrows  to view more fields.

➤ Continued

\* **Tip**  
If multiple contacts share information, such as a company name and address, you can enter the first contact, and then **copy the information into other contacts**.

+ **Did You Know?**  
If you want a reminder about a birthday, select the Reminder box, enter the number of days before the birthday that you want to see the reminder, and then select OK.

\* **Tip**  
Birthdays you enter in Contacts appear as untimed events in Calendar. If you update the birthday in Contacts, it automatically updates in Calendar as well.

3

[ & ] **OPTIONAL** Add a photo:

- Tap the Picture box.
- Select and add a photo from palmOne™ Media.

Contact Edit Unfiled

First name: Lee

Picture:  Tap here

Company: Example, Inc.

Title:

Work: 555-234-1939

Home:

Mobile: 555-616-2117

Done Details... + -

4

[ & ] **OPTIONAL** Add a birthday:

- Tap the Birthday box.
- Select the birth year, month, and date.

Contact Edit Unfiled

Addr(W): 4929 Rockaway Dr.

City: Anytown

State: CA

Zip Code: 90000

Country:

Birthday: - Tap to add - Tap here

Custom 1:

5

After you finish entering all the information you want, select Done.

↓ Done

That's it. Your handheld automatically saves the contact. Make sure you have a current backup. **Synchronize** often.



## Locating a contact on your list

### \* Tip

You can also press Right on the 5-way navigator (or tap the Quick Look Up icon at the top of the screen) to open the Quick Look Up line. Press Up and Down to select the letter of the name you want in each box, and press Right to move to the next box.

### + Did You Know?

The **Phone Lookup** feature lets you add contact information directly into certain other applications on your handheld. For example, you can add a name and phone number to a memo or task.

<b>1</b>	Press the Contacts  button.
<b>2</b>	<p>Search for the contact:</p> <p>a. Tap the Look Up line at the bottom of the screen and enter the first letter of the name you want to find.</p> <p>b. Enter the second letter of the name, and so on, until you can easily scroll to the contact you want.</p>
<b>3</b>	<p>Select the contact to open it.</p> <p> Done</p>



Quick Look Up icon



## Beaming a contact

\* **Tip**  
You can create a contact with your own information and select it as your business card by opening the Record menu and selecting Business Card. Beam your business card to other handhelds by holding down the Contacts button until the Beam dialog box appears.

+ **Did You Know?**  
A Beam command appears on the left-most menu of most applications. Use it to beam information such as photos, appointments, and more.

\* **Tip**  
You can also **send a contact wirelessly** using the Send command with your handheld's built-in Bluetooth technology.

**1**

Press the Contacts  button.

**2**

Beam the contact:

- Locate the contact** you want to beam.
- Select Menu  on the status bar.
- Select Record, and then select Beam Contact.
- When the Beam Status dialog box appears, point your handheld's IR port directly at the IR port of the other handheld.



**NOTE** For best results, the handhelds should be between 4 and 36 inches apart, and there should be a clear path between them. Depending on the receiving handheld model, not all information may be sent correctly.

**3**

Wait for the Beam Status dialog box to indicate that beaming is complete.

↓ Done

**User Guide**

For everything you need to know about your handheld—all that's in this guide, and much more—go to [www.palmOne.com/tungstent5-userguide](http://www.palmOne.com/tungstent5-userguide).

**My Handheld**

Make your handheld uniquely yours. For great tips, software, accessories, and more, visit [www.palmOne.com/mytungstent5](http://www.palmOne.com/mytungstent5).

**Support**

If you're having problems with Contacts or with anything else on your handheld, go to [www.palmOne.com/support/tungstent5](http://www.palmOne.com/support/tungstent5).

## Beyond the basics

Click the link to the left to go to the *User Guide* on the web and learn about these related topics:

Contacts	<ul style="list-style-type: none"><li>• Deleting contacts</li><li>• Removing a photo from a contact</li><li>• Displaying additional contact fields and defining custom fields</li><li>• Choosing the field type for certain fields, such as Home or Work for a phone number</li><li>• Using Quick Connect to make a phone call, address and send an email or text message, or go to a web page directly from a contact</li></ul>
Categories	Organizing contacts by type and sorting them
Information	Transferring contact information from other applications such as databases, spreadsheets, and other organizer software
Privacy	Keeping contacts private by turning on security options
Sharing	Sending contacts to other Bluetooth devices by using Bluetooth technology on your handheld
Email	Sending contacts as attachments to email messages

# Managing Your Calendar

## In this chapter

[Scheduling an appointment](#)

[Checking your schedule](#)

[Setting an alarm](#)

[Beyond the basics](#)

Staying on top of your schedule is an important part of being productive both at work and at home. Calendar can help you remember appointments and spot schedule conflicts. You can view your calendar by day, week, or month, or as an agenda list that combines your list of tasks with your appointments.



## Benefits

- Track current, future, and past appointments
- Stay on top of deadlines
- Carry one calendar
- Spot schedule conflicts

## Scheduling an appointment

## » Key Term

**Event** The name for an entry in the Calendar application, including appointments, birthdays, reminders, recurring meetings, and so on.

## \* Tip



You can also scroll to a date by pressing Right or Left on the 5-way navigator or by tapping the arrows at the top of the Day View.

## + Did You Know?

You can use more than one line to describe an appointment.

1

Open Day View:

- Press the Calendar  button.
- Tap the Day View icon .

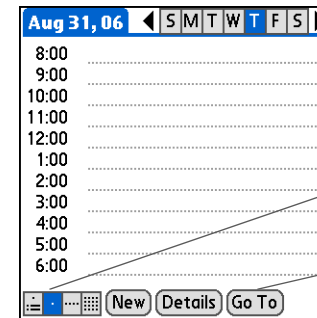

Day View icon

Go To

2

**[ & ] OPTIONAL** If the appointment is not for today, select the date of the appointment:

- Tap Go To.
- Select the year, month, and date.

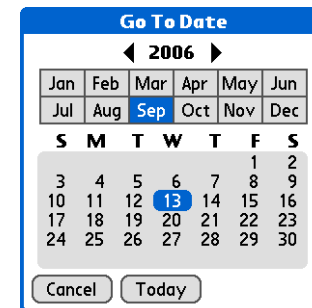

3

Tap the line next to the time the appointment begins and **enter a description**.

↘ Continued

- \* **Tip**  
To enter reminders, holidays, anniversaries, and other events that take place on a particular date but not at a particular time, select **No Time**.
- \* **Tip**  
Color-code your calendar. Tap the bullet next to the description to file the appointment in a category. Each category has its own color.

## 4

If the appointment is longer or shorter than an hour, set the duration:

- a. In Day View, tap the start time.
- b. In the Set Time dialog box, tap End Time.
- c. Tap the hour and minute lists to select the time the appointment ends.
- d. Select OK.

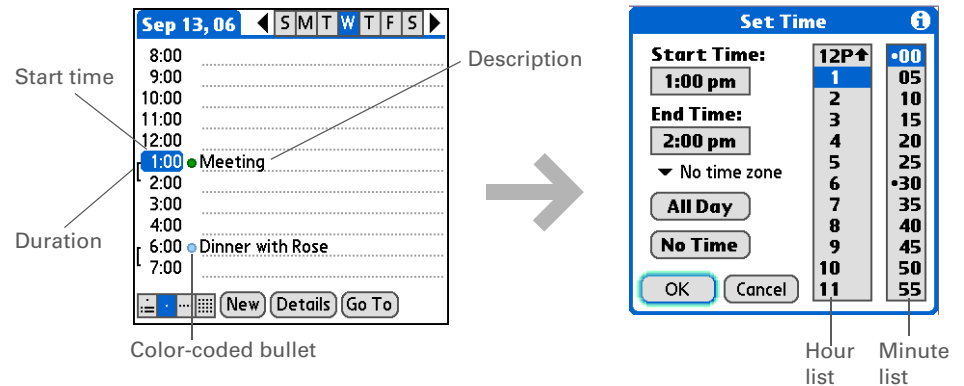

↓ Done That's it. Your handheld automatically saves the appointment. Make sure you have a current backup. Synchronize often.

## Checking your schedule

Sometimes you want to look at your schedule for a particular date, while other times you want to see an overview of a week or month.

\* **Tip**  
Press the Calendar button repeatedly to cycle through the Agenda View, Day View, Week View, and Month View.

\* **Tip**  
You can also display Year View. From Month View, tap Year.

+ **Did You Know?**  
You can use a favorite photo as the background for your Agenda View.

**1** Press the Calendar  button.

**2** Tap the icons in the lower-left corner to see four different Calendar views:

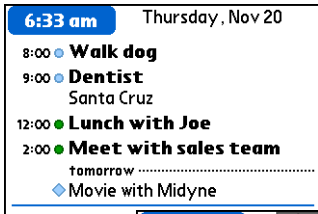

Agenda View

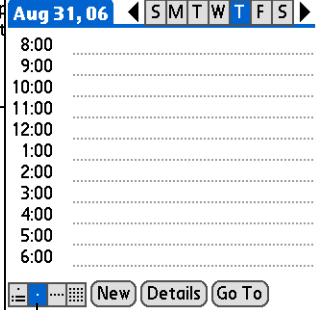

Day View

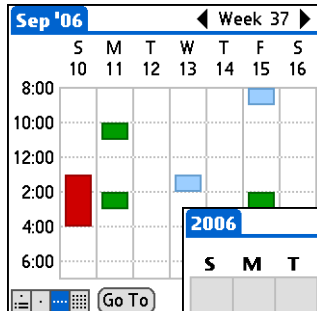

Week View

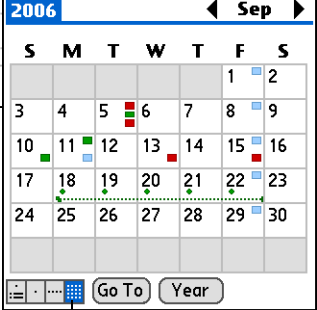

Month View

 Done

## Setting an alarm

**+ Did You Know?**  
Setting your alarm sounds in World Clock instead of in Calendar gives you different alarm sound choices.

**\* Tip**  
Check out the other options in the Event Details dialog box. For example, Repeat creates an event that recurs daily, weekly, or at whatever interval you set up.

**+ Did You Know?**  
When you set an alarm, a little alarm clock appears to the right of the event description.

- 1** Press the Calendar  button.
- 2** Go to the event you want to assign an alarm to:
  - a. From Day View, tap Go To.
  - b. Select the year, month, and date of the event.
  - c. Tap the event description.
- 3** Set the alarm:
  - a. Tap Details.
  - b. Check the Alarm box.
  - c. Select the pick list and select Minutes, Hours, or Days.
  - d. Enter how many minutes, hours, or days before the event you want the alarm to sound, and then select OK.

Event Details i

**Time:** 1:00 pm - 2:00 pm

**Date:** Wed 9/13/06

**Alarm:**  5 ▼ Minutes

**Location:** .....

**Category:** ▼ Unfiled

**Repeat:** ▼ None

**Private:**

**↓ Done**

**User Guide**

For everything you need to know about your handheld—all that's in this guide, and much more—go to [www.palmOne.com/tungstent5-userguide](http://www.palmOne.com/tungstent5-userguide).

**My Handheld**

Make your handheld uniquely yours. For great tips, software, accessories, and more, visit [www.palmOne.com/mytungstent5](http://www.palmOne.com/mytungstent5).

**Support**

If you're having problems with Calendar or with anything else on your handheld, go to [www.palmOne.com/support/tungstent5](http://www.palmOne.com/support/tungstent5).

## Beyond the basics

Click the link the left to go to the *User Guide* on the web and learn about these related topics:

Calendar	<ul style="list-style-type: none"> <li>• Creating repeating events for things you do at regular intervals, such as taking a class at the gym three days a week or taking a biweekly music lesson</li> <li>• Set a time zone for an individual appointment different from the location you set for your handheld</li> <li>• Reserving blocks of time for long events like vacations or conferences</li> <li>• Choosing the default Calendar view format and the information that appears in each view by setting display options</li> <li>• Customizing alarm settings and choosing what time days start and end by setting preferences</li> <li>• Storing extra information about an event by adding a note</li> <li>• Erasing old appointments by purging them</li> </ul>
Categories	Organizing events by type and color-coding them
Privacy	Keeping events private by turning on security options
Sharing	<ul style="list-style-type: none"> <li>• Beaming events to other Palm Powered™ devices</li> <li>• Sending events to other Bluetooth® devices by using Bluetooth wireless technology on your handheld</li> </ul>
Email	Sending events as attachments to email messages



# Managing Your Office Files

## In this chapter

[How can I create and manage Office files?](#)

[Beyond the basics](#)

With its ability to store large amounts of important information, your handheld lets you take your office with you—including your Microsoft Office files. With the Documents application, you can carry, create, view, and edit Microsoft Word and Excel files directly on your handheld. You can also view, carry, and manage PowerPoint files on your handheld.

You can keep updated copies of the files on both your handheld and your computer to work on them in the most convenient location any time.



## Benefits

- Manage Word, Excel, and PowerPoint files on your handheld
- Improve productivity by taking important docs, spreadsheets, and presentations with you on the go

**\* Tip**

The Documents application has a companion application on your computer called Documents To Go. Use Documents To Go to move or copy files to the Documents folder on your handheld's internal drive when you synchronize.

For complete information on this application, click the Documents To Go icon on your computer and then click Help, or go to [www.dataviz.com](http://www.dataviz.com).

## How can I create and manage Office files?

The Documents application provides powerful editing and file management features for Office files on your handheld. What's more, Documents makes it easy for you to share files between your computer and your handheld, using either **File Transfer** or **synchronization**. Here are some of the capabilities of Documents:

- View Word, Excel, and PowerPoint files in their native format (DOC, XLS, or PPT); no conversion needed.
- Create or edit a Word document or Excel spreadsheet on your handheld and save it in native format. Create or edit a PowerPoint presentation that is automatically converted for optimal viewing on your handheld.
- Open Office files received as attachments to incoming email messages, and attach files to outgoing messages.
- View files such as spreadsheets in **landscape mode** to see more information across the screen.

## Opening files from within Documents

In the Documents application, you can view and open any Word, Excel, or PowerPoint file on your handheld.

**\* Tip**

When you are working on a file, save it to a specific location on your handheld's internal drive by selecting Menu on the status bar, selecting Save As from the File menu, and then navigating to the location where you want to save the file.

**\* Tip**

You can choose to synchronize a Word, Excel, or PowerPoint file from within the Documents application, even if you copied it using File Transfer. See the Documents To Go application on your computer for information.

**1**

**Go to Favorites** and select Documents.

**2**

**[ & ] OPTIONAL** If the file you want does not appear in the list, browse for the file:

- a. Select Menu  on the status bar, and then select File.
- b. Select Search For Files.

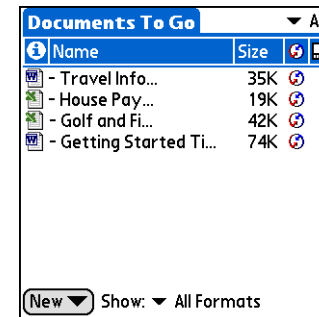

**3**

Select the file you want from the list.

 Done

## Beyond the basics

Click the link to the left to go to the *User Guide* on the web and learn about these related topics:

Email

Sending and receiving Office files as attachments to email messages

### User Guide

For everything you need to know about your handheld—all that's in this guide, and much more—go to [www.palmOne.com/tungstent5-userguide](http://www.palmOne.com/tungstent5-userguide).

### My Handheld

Make your handheld uniquely yours. For great tips, software, accessories, and more, visit [www.palmOne.com/mytungstent5](http://www.palmOne.com/mytungstent5).

### Support

If you're having problems with Docs, click the Documents To Go icon on your computer, and then click Help, or go to [www.dataviz.com](http://www.dataviz.com).

# Viewing Photos and Videos

## In this chapter

[Supported file types](#)

[Viewing photos or videos](#)

[Organizing photos or videos into albums](#)

[Sharing photos and videos](#)

[Sending a photo or video using Bluetooth technology](#)

[Beyond the basics](#)

A picture may be worth a thousand words, but what happens when you have a lots of pictures—or videos—that you are trying to keep organized? Or maybe just a few that are so meaningful that you want to have instant access to them at any time?

Solve both problems with palmOne™ Media. Media features easy viewing and organization of still photos and videos. You can keep your favorite photos right on your handheld; **select photos as the background** for your Favorites and Applications Views and for Agenda View in Calendar; even **add a photo to a Contacts entry**.



## Benefits

- Never be far from your favorite people or places
- Simplify photo and video organization
- Store multiple videos and photos

**\* Tip**

If you want to carry a video on your handheld to view on another computer, use palmOne File Transfer (Windows) or Drive Mode (Mac) on your computer. These apps transfer the video to your handheld in its native format with no conversion, so you can view it on the computer in the format you prefer.

## Supported file types

When you **copy a photo or video from your computer**, you can save it directly on your handheld or on an **expansion card** (sold separately) inserted into the expansion slot.

You can view photos in popular formats such as JPG, BMP, TIFF (uncompressed), and GIF on your handheld. On a Windows computer, when you copy a photo in a popular format to your handheld using the Media desktop application from within Palm® Desktop software, the photo is saved on your handheld in its original format. If you copy a photo in a different format, it is saved on your handheld in JPG format.

On a Mac computer, all photos you copy by dragging them onto the Send To Handheld droplet icon are saved on your handheld in JPG format.

To view a video on your handheld, on a Windows computer, open Media from within Palm Desktop software, add the video, and then synchronize to send the video to your handheld. On a Mac computer, drag the video to the Send To Handheld droplet, and then synchronize. The video is converted to a format (ASF (MPEG-4)) your handheld can play and is optimized for viewing on the handheld.

For both Windows and Mac computers, note that there are numerous video formats, and even many variations within the ASF (MPEG-4) format. Not all types can be converted to a format that's viewable on your handheld. If you can't open and view a video in the desktop Media application on a Windows computer, you won't be able to view the video on your handheld.

## Viewing photos or videos

\* **Tip**  
Select Slide Show to display all photos and videos in an album, automatically, one after another. Tap a photo or video to stop the slide show.

+ **Did You Know?**  
Photos and videos located in the Photos & Videos folder on your handheld are backed up to your computer when you **synchronize**.

1

**Go to Favorites** and select Photos & Videos .

2

Tap the pick list in the upper-right corner and select the location on your handheld or an expansion card of the photo or video you want to view:

- If the photo or video is in the Photos & Videos folder on your handheld's internal drive or on an expansion card, select the correct location from the list.
- If the photo or video is located elsewhere on your handheld's internal drive, select Find More and browse to the item.

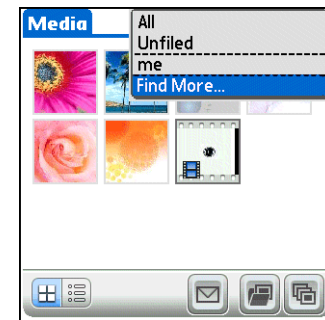

↘ **Continued**

**3**

Select the photo or video you want to view.

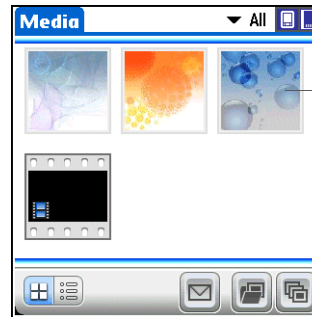

Select a photo or video to view

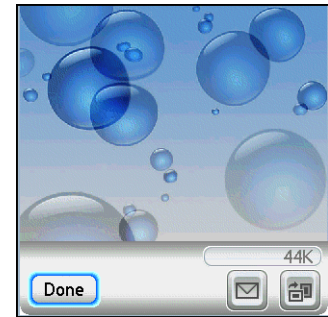
**4**

Tap anywhere in the photo or video to return to the selection screen.

↓ Done



## Organizing photos or videos into albums

### \* Tip

If a photo is stored on your handheld, you can only add it to an album located on the handheld. Likewise, if a photo is stored on an expansion card, you can only add it to an album that is on the same card. Use the **copy** feature to move a photo from your handheld to a card and vice versa.

**1**

**Go to Favorites** and select Photos & Videos .

**2**

Open the Manage Albums screen:

- Select Menu  on the status bar.
- Select Album, and then select Manage Albums.

**3**

Create an album:

- Select whether to create the album on your handheld or on an expansion card inserted in the expansion slot.
- Select New, enter the name of the new album, and select OK.
- Select OK on the Manage Albums screen.

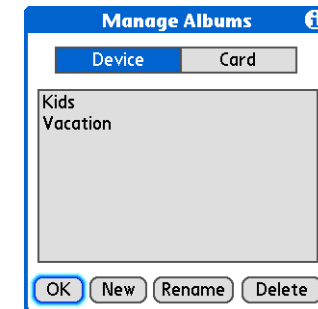

↘ Continued

\* **Tip**

If you are not already in the album to which you want to add or remove photos or videos, select the pick list in the upper-right corner and select the album you want.

\* **Tip**

If the buttons don't appear when viewing a photo, make sure the photo is fully zoomed out by pressing Down on the 5-way. Tap the photo to return to the original view.

**4**

Add or remove photos or videos in albums:

- Select Manage Albums .
- Select a photo or video that does not have a plus sign to add it to the album.
- Select a photo or video with a plus sign to the left to remove it from the album.
- Select Done.

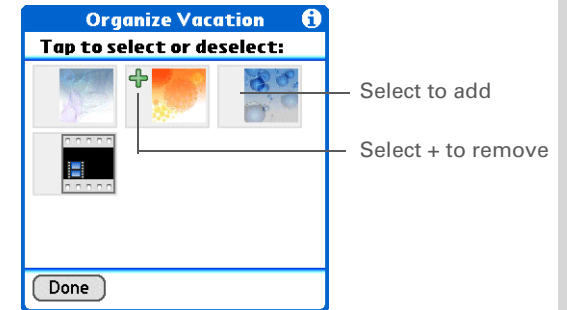
**5**

Move photos or videos within albums:

- Tap the pick list in the upper-right corner and select the album in which you want to move photos or videos.
- Select the photo you want to move, and drag the stylus to move the photo or video to the desired location.

↓ Done

## Sharing photos and videos

You can easily share photos with family and friends using any of the following methods:

- **Use your handheld's built-in Bluetooth® wireless technology** to wirelessly send photos and videos to other Bluetooth devices within range.
- **Attach a photo or video** to an email message.
- **Beam a photo or video** to other Palm Powered™ devices.
- Copy a photo or video to your handheld using **File Transfer** and then carry it to and work with it on another computer using File Transfer (if it is installed on the computer where you are a guest) or **Drive Mode**.

**NOTE** Beaming a photo or video file or sending a file using Bluetooth technology can take some time, so be patient if sending by these methods.

## Sending a photo or video using Bluetooth technology

+ **Did You Know?**  
If you select Send before selecting a photo or video, a dialog box appears from which you can select the item you want to send.

\* **Tip**  
Also **use the buttons at the bottom of the screen** to switch between Thumbnail view and List view, view photos as a slide show, or rotate a photo.

**1**

**Go to Favorites** and select Photos & Videos .

**2**

Send a photo or video:

- a. Tap the pick list in the upper-right corner and select the album containing the photos and/or videos you want to send, or select Find More to browse for the photo or video.
- b. Select the photo or video you want to send.
- c. Select Send .
- d. Select Bluetooth, and then tap OK.
- e. Select the device to which you want to send the photo or video, and then tap OK. The file is sent automatically.

 Done

## Beyond the basics

Click the link to the left to go to the *User Guide* on the web and learn about these related topics:

### Media

- Viewing photos and videos as thumbnails, lists, albums, and slide shows
- Copying photos and videos to other applications or expansion cards
- Editing and enhancing photos and videos on your desktop computer
- Deleting photos and videos
- Sending photos from the Media desktop application via email

### Email

Sending photos and videos as attachments to email messages

### User Guide

For everything you need to know about your handheld—all that's in this guide, and much more—go to [www.palmOne.com/tungstent5-userguide](http://www.palmOne.com/tungstent5-userguide).

### My Handheld

Make your handheld uniquely yours. For great tips, software, accessories, and more, visit [www.palmOne.com/mytungstent5](http://www.palmOne.com/mytungstent5).

### Support

If you're having problems with Media or with anything else on your handheld, go to [www.palmOne.com/support/tungstent5](http://www.palmOne.com/support/tungstent5).

# Listening to Music

## In this chapter

[Transferring MP3 files to your handheld](#)

[Transferring music from a CD to your handheld](#)

[Playing music on your handheld](#)

[Beyond the basics](#)

Are you tired of listening to small talk during that long commute on the bus or train? Do you need something smaller than a CD player when you're out for a walk or at the gym?

RealPlayer from palmOne lets you play music on your handheld. Simply transfer songs onto your handheld and then listen through the built-in speaker or stereo headphones (sold separately).



## Benefits

- Listen to songs in the popular MP3 format
- No separate MP3, CD, or mini-disc player required
- Be your own DJ

## Transferring MP3 files to your handheld

\* **Tip**  
 You can also transfer MP3 files by dragging a folder of files or individual files to the File Transfer application on your desktop, and then dragging the item(s) to the Music folder in the File Transfer window. This is useful if you want to copy an entire folder of music to your handheld, for example, to keep all the songs from the same CD in one folder.

The RealPlayer software that comes with your handheld is compatible with the popular MP3 audio file format. Use the RealPlayer desktop application on your computer to copy MP3 files to your handheld's internal drive.

### WINDOWS ONLY

**1**

**Connect your handheld and your computer to the USB sync cable.**

**2**

Prepare RealPlayer on your computer:

- a. Open the RealPlayer application.
- b. Select palmOne Handheld from the Current Burner/Device drop-down list.

Select  
palmOne  
Handheld

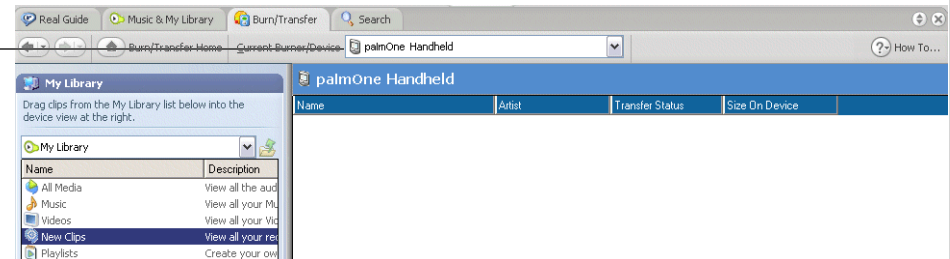

**3**

Drag the music files from your desktop onto the palmOne Handheld window. The files are transferred to the Music folder on your handheld's internal drive.

↓ Done

**\* Tip**

You can also transfer MP3 files on a Mac computer by dragging the music file to the Send To Handheld droplet. Select the destination for the file, and then **synchronize** to transfer it.

**MAC ONLY****1**

Prepare your handheld:

- a. **Go to Applications** and select Drive Mode .
- b. **Connect your handheld and your computer to the USB sync cable.**

**2**

Open Finder, and then drag the music files you want on to the Music folder under the handheld icon, which appears as an external drive on your desktop.

**[ ! ] IMPORTANT** When finished transferring music files, be sure to properly **disconnect from Drive Mode**.

↓ Done



## Transferring music from a CD to your handheld

### [ ! ] Before You Begin

**Windows:** Install RealPlayer desktop application on your computer. Insert the software installation CD and follow the onscreen instructions for installing extra software.

You must install this software, even if you already have a version of RealPlayer installed on your computer. The version on the CD contains all of the components needed to transfer music files to your handheld.

If your songs are on a CD and you want to listen to them on your handheld, use the RealPlayer desktop application on your computer to convert and transfer the files.

**NOTE** Mac users can use iTunes, included with OS X, to transfer music from a CD to their handheld. Music files should be imported in MP3 format.

### WINDOWS ONLY

# 1

Access the music CD from RealPlayer on your computer:

- Double-click the RealPlayer icon  on your computer desktop.
- Insert the CD into your computer's CD drive.
- If the track listing does not appear, click Music & My Library, and then click CD/DVD in the View menu.

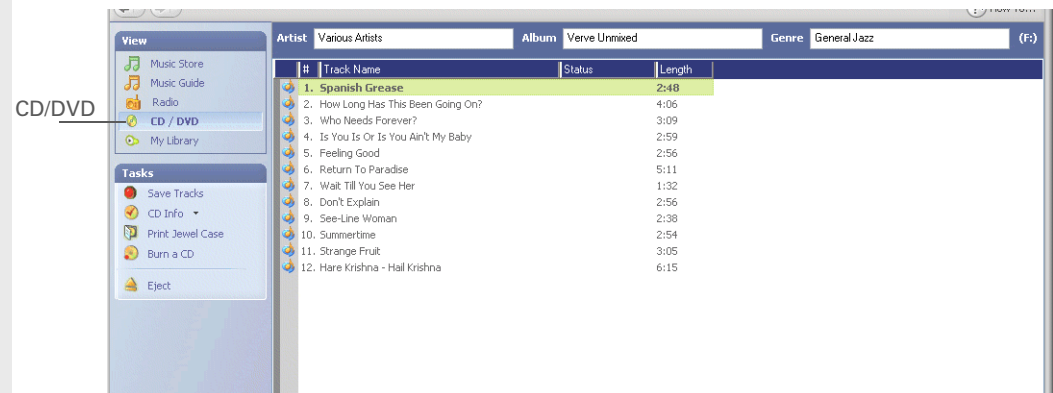

➤ Continued

\* **Tip**  
If you want to select only a few songs, click **Deselect All** and then check the box next to the songs you want to select.

+ **Did You Know?**  
The RealPlayer application on your handheld plays music files in the MP3 format only. Go to [www.real.com](http://www.real.com) to update the application to a version that supports other formats such as AAC.

## 2

Select the songs you want to add to your library:

- a. Click **Save Tracks**.
- b. Follow the onscreen instructions to select and copy tracks.

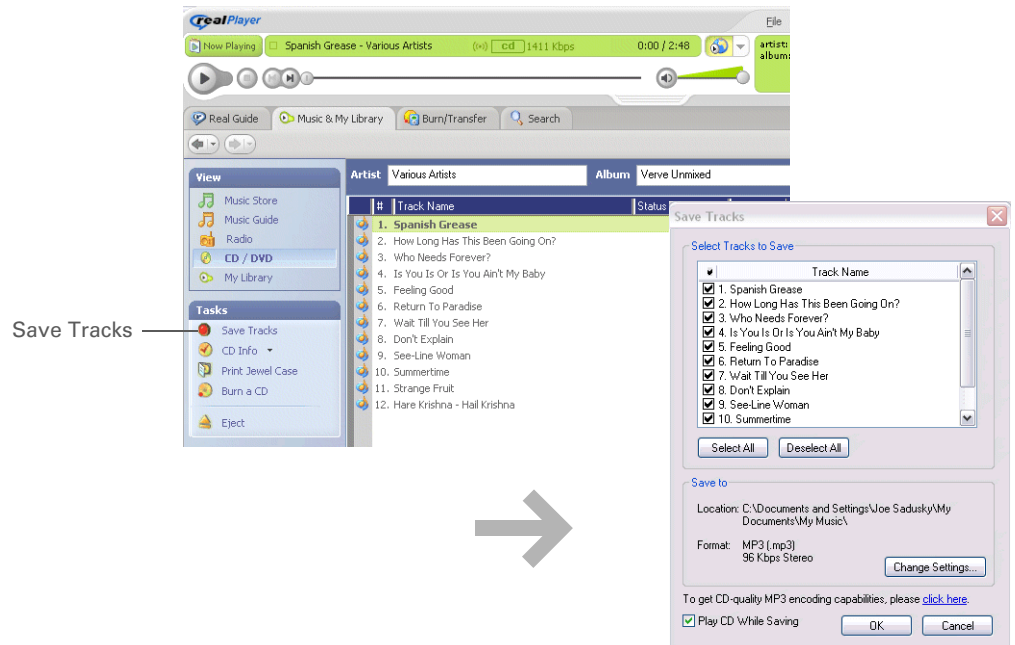

↘ Continued

## \* Tip

For tips on using RealPlayer on your computer, go to the Help menu in RealPlayer or visit [www.real.com](http://www.real.com).

## 3

Prepare your handheld:

- a. **Go to Favorites** and then select Music .
- b. **Connect your handheld and your computer to the USB sync cable.**

[ ! ] **IMPORTANT** Do not press the HotSync button on your cable.

## 4

Select the songs you want to transfer:

- a. In RealPlayer on your computer, click Burn/Transfer.
- b. If necessary, select palmOne Handheld from the Current Burn/Transfer Device drop-down list.
- c. Drag the song files you want from the My Library window on the left into the palmOne Handheld window on the right.

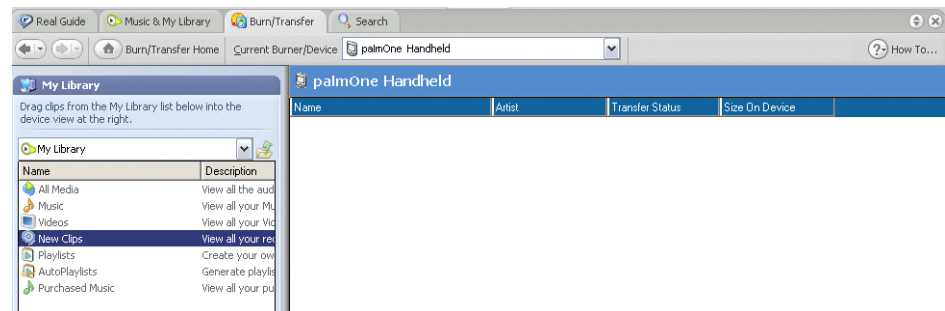

➤ Continued

**\* Tip**

On your handheld, tap Songs to view a list of the songs available for you to play. The songs you just transferred are at the bottom of the list.

**5**

Transfer the selected songs to your handheld:

- a. Be sure your handheld is on and that RealPlayer is open. If it is, a green Connected light appears in the lower-left corner of RealPlayer on your computer.
- b. Click Start Transfer. When the transfer is complete, the tracks you selected should say "On Device." The files are transferred to the Music folder on your handheld's internal drive.

**[ ! ] IMPORTANT** Do not press the HotSync button on your cable. RealPlayer is transferring the files, so there's no need to do anything.

↓ Done

## Playing music on your handheld

\* **Tip**  
For tips on using RealPlayer, [open the Options menu](#) and select Help.

+ **Did You Know?**  
RealPlayer continues playing the songs in your list until it reaches the end of your list or until you tap the Stop button, even if your handheld screen is off.

\* **Tip**  
If you want to download songs from the Real Music Store (U.S. only; additional fees may apply), you need to download and install a special version of RealPlayer that is compatible with Real Music Store files.

**1**

On your handheld, **go to Favorites** and then select Music .

**2**

Select a song to play:

- To play the current song, tap Play.
- To play a different song, tap Songs and select a song from the list.
- To play a song that is not located in the Songs list, select Menu  on the status bar, select Play Folder, and navigate to the song you want.

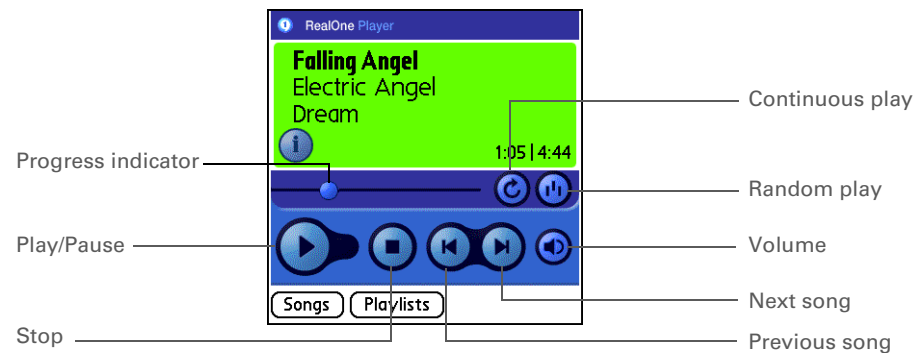
**3**

When you've finished listening, tap the Stop button.

↓ Done

## Beyond the basics

Click the link to the left to go to the *User Guide* on the web and learn about these related topics:

### RealPlayer

- Creating playlists by choosing which songs to play and the order to play them in
- Removing songs from your handheld or an expansion card

### User Guide

For everything you need to know about your handheld—all that's in this guide, and much more—go to [www.palmOne.com/tungstent5-userguide](http://www.palmOne.com/tungstent5-userguide).

### My Handheld

Make your handheld uniquely yours. For great tips, software, accessories, and more, visit [www.palmOne.com/mytungstent5](http://www.palmOne.com/mytungstent5).

### Support

If you're having problems with RealPlayer on your handheld or your computer, go to [www.real.com](http://www.real.com).

# Managing Your Tasks

## In this chapter

[Creating a task](#)

[Organizing your tasks](#)

[Marking a task complete](#)

[Beyond the basics](#)

Some of the most successful people in the world are also the busiest. When asked how they manage to do it all, busy people usually say, "I make lists." The Tasks application on your handheld is the perfect place to make lists of the things you need to do.



## Benefits

- Set priorities
- Track deadlines
- Stay focused

## Creating a task

\* **Tip**  
If no task is currently selected, you can create a new task simply by starting to write in the input area.

\* **Tip**  
Set an alarm for the selected task. Tap Details, check the Alarm box, tap the Alarm box, enter the alarm settings, and then select OK.

\* **Tip**  
You can beam tasks to anyone who has a handheld with an IR port. Just **open the Record menu** and select Beam Item or Beam Category.

1

**Go to Applications** and select Tasks .

2

Create a task:

- Select New.
- Enter a description of the task.

Tasks	All	Date	Category	
<input type="checkbox"/> 2	Distribute meeting notes	11/6!		Due date
<input type="checkbox"/> 1	Update project schedule	11/7		
<input type="checkbox"/> 2	Oil change	11/10		
<input type="checkbox"/> 1	Pay bills	11/14		
<input type="checkbox"/> 2	Get football tickets	11/14		
<input type="checkbox"/> 3	Buy anniversary gift for	11/26		Long description
	Midyne & Greg			
<input type="checkbox"/> 1	Submit monthly accruals	11/27		New task
<input checked="" type="checkbox"/> 1	Call painter	-		Priority number
<input type="checkbox"/> 4	Wash car	-		

New Details...  ↓

Note button

3

**[ & ] OPTIONAL** Assign a priority and due date:

- Tap the priority number and select a number (1 is the most important).
- Tap the due date and select a date from the list, or select Choose Date to select a date from the calendar.

↓ Done

**That's it. Your handheld automatically saves the task. Make sure you have a current backup. Synchronize often.**



## Organizing your tasks

Sometimes you want to look at all the things you need to do, while at other times you want to see only certain types of tasks.

**+ Did You Know?**  
Overdue tasks have an exclamation point (!) next to the due date.

**\* Tip**  
Your Task Preferences settings control which tasks appear in the Tasks list, such as completed or due tasks. To change these settings, open the Options menu and select Preferences.

**\* Tip**  
Create a new category for tasks by selecting Edit Categories in the Category pick list.

1

**Go to Applications** and select Tasks .

2

In the Tasks list, select one of these options:

**All** Displays all your tasks.

**Date** Displays tasks that are due in a specific time frame. Tap the pick list in the upper-right to select Due Today, Last 7 Days, Next 7 Days, or Past Due.

**Category** Displays tasks that are assigned to the selected category. Tap the pick list in the upper-right to select a different category.

Tasks	All	Date	Category
<input type="checkbox"/> 2 Distribute meeting notes		11/6!	
<input type="checkbox"/> 1 Update project schedule		11/7	
<input type="checkbox"/> 2 Oil change		11/10	
<input type="checkbox"/> 1 Pay bills		11/14	
<input type="checkbox"/> 2 Get football tickets		11/14	
<input type="checkbox"/> 3 Buy anniversary gift for Midyne & Greg		11/26	
<input type="checkbox"/> 1 Submit monthly accruals		11/27	
<input type="checkbox"/> 4 Call painter		-	
<input type="checkbox"/> 4 Wash car		-	

New Details... 

Tasks	All	Date	Category
<input type="checkbox"/> 2 Distribute meeting notes		Due Today - 1	
<input type="checkbox"/> 1 Update project schedule		Last 7 Days - 2	
		Next 7 Days - 3	
		Past Due - 1	

New Details... 

Tasks	All	Date	Category
<input type="checkbox"/> 2 Distribute meeting notes			Business
<input type="checkbox"/> 1 Update project schedule			Personal
<input type="checkbox"/> 1 Submit monthly accruals			Unfiled
			Edit Categories...

New Details... 

↓ Done

## Marking a task complete

You can check off a task to indicate that you've completed it.

\* **Tip**

You can set Task Preferences to record the date that you finish your tasks, and you can show or hide finished tasks. To change these settings, **open the Options menu** and select Preferences.

1

**Go to Applications** and select Tasks .

2

Check the box on the left side of the task.

↓ Done

Tasks	All	Date	Category
▼ Personal			
<input checked="" type="checkbox"/> 4	Wash car	11/7	
<input checked="" type="checkbox"/> 2	Oil change	11/7	
<input type="checkbox"/> 1	Pay bills	11/14	
<input type="checkbox"/> 3	Buy anniversary gift for Midyne & Greg	11/26	
<input type="checkbox"/> 4	Call painter	-	

**NOTE** Palm® Desktop software and Microsoft Outlook handle completed repeating tasks differently. Palm Desktop software checks off all overdue instances of the task, and Microsoft Outlook checks off only the oldest instance of the task.

### User Guide

For everything you need to know about your handheld—all that's in this guide, and much more—go to [www.palmOne.com/tungstent5-userguide](http://www.palmOne.com/tungstent5-userguide).

### My Handheld

Make your handheld uniquely yours. For great tips, software, accessories, and more, visit [www.palmOne.com/mytungstent5](http://www.palmOne.com/mytungstent5).

### Support

If you're having problems with Tasks or with anything else on your handheld, go to [www.palmOne.com/support/tungstent5](http://www.palmOne.com/support/tungstent5).

## Beyond the basics

Click the link to the left to go to the *User Guide* on the web and learn about these related topics:

- |         |  |
|---------|--|
| Tasks   | <ul style="list-style-type: none"><li>• Creating repeating tasks for things you need to do at regular intervals, such as taking out the trash on Thursday night or filing a weekly status report</li><li>• Setting alarms when you use tasks as reminders</li><li>• Setting preferences to choose which tasks appear in the Tasks list, whether to track completion dates, and which alarm sound plays</li><li>• Storing extra information about a task by adding a note</li></ul> |
| Privacy | Keeping tasks private by turning on security options   |
| Email   | Sending tasks as attachments to email messages   |
| Sharing | <ul style="list-style-type: none"><li>• Beaming tasks to other Palm Powered™ devices</li><li>• Sending tasks to other Bluetooth® devices by using Bluetooth technology on your handheld</li></ul>  |

# Writing Memos

## In this chapter

[Creating a memo](#)

[Viewing and editing a memo](#)

[Beyond the basics](#)

Your handheld contains applications for storing the most common types of information: contact names and numbers, appointments, and so on. Memos is the tool to use for capturing information that is meaningful to you but does not fall into one of these categories. From meeting notes to recipes and favorite quotations, Memos provides a quick and easy way to enter, store, and share your important information.



## Benefits

- Store essential but hard-to-remember information
- Easily retrieve and share information

## Creating a memo

\* **Tip**  
In the Memos list, you can also just start writing to create a new memo. The first letter is automatically capitalized.

\* **Tip**  
Use **Phone Lookup** to quickly add a name and phone number to a memo.

**1** Go to Applications and select Memos .

**2** Create a memo:

a. Select New.

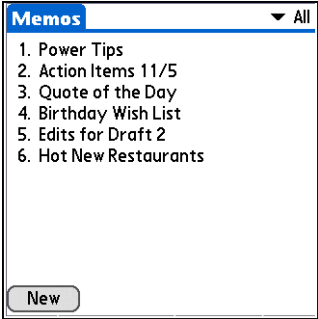

1. Power Tips  
2. Action Items 11/5  
3. Quote of the Day  
4. Birthday Wish List  
5. Edits for Draft 2  
6. Hot New Restaurants

New

→

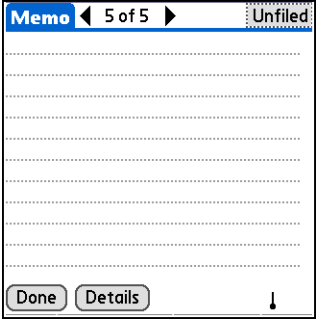

Memo ◀ 5 of 5 ▶ Unfiled

Done Details ↓

b. Enter your memo. Tap Enter on the onscreen keyboard or draw the **Graffiti® 2 writing** Return stroke / to move to a new line in the memo.

c. Select Done.

↓ Done That's it. Your handheld automatically saves the memo. Make sure you have a current backup. Synchronize often.

## Viewing and editing a memo

\* **Tip**  
The Memos list shows the first line of each memo, so make sure that first line is something you will recognize.



+ **Did You Know?**  
You can connect your handheld to a portable keyboard and type your memos on the go without carrying around a heavy laptop. You can purchase a variety of portable keyboards. Visit [www.palmOne.com/mytungstent5](http://www.palmOne.com/mytungstent5) and click the Accessories link.

\* **Tip**  
You can **change the size of the text** in Memos to enhance readability.

**1** **Go to Applications** and select Memos .

**2** View or edit the memo:

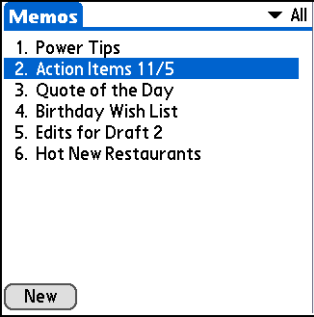
a. In the Memos list, select the memo you want.

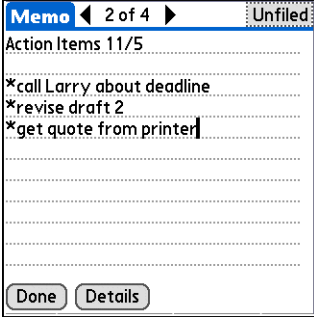
b. Read or edit the memo, and then select Done.

↓ Done

**User Guide**

For everything you need to know about your handheld—all that's in this guide, and much more—go to [www.palmOne.com/tungstent5-userguide](http://www.palmOne.com/tungstent5-userguide).

**My Handheld**

Make your handheld uniquely yours. For great tips, software, accessories, and more, visit [www.palmOne.com/mytungstent5](http://www.palmOne.com/mytungstent5).

**Support**

If you're having problems with Memos or with anything else on your handheld, go to [www.palmOne.com/support/tungstent5](http://www.palmOne.com/support/tungstent5).

## Beyond the basics

Click the link to the left to go to the *User Guide* on the web and learn about these related topics:

Memos	<ul style="list-style-type: none"><li>• Deleting memos</li><li>• Sending memos to your computer by synchronizing so you can cut text from a memo and paste it into an application such as Microsoft Word</li></ul>
Categories	Organizing memos by arranging them into categories and sorting them
Privacy	Keeping memos private by turning on security options
Sharing	<ul style="list-style-type: none"><li>• Beaming memos to other Palm Powered™ devices</li><li>• Sending memos to other Bluetooth® devices using the Bluetooth wireless technology on your handheld</li></ul>
Email	Sending memos as attachments to email messages

# Writing Notes in Note Pad

## In this chapter

[Creating a note](#)

[Viewing and editing a note](#)

[Beyond the basics](#)

Need to jot down a phone number or a reminder to yourself? Avoid fumbling for scraps of paper, and write important reminders in Note Pad. You can use Note Pad to do everything you might do with a piece of paper and a pencil. Note Pad gives you a place to draw freehand and take notes in your personal handwriting, which is even faster and more flexible than creating a memo on your handheld.



## Benefits

- No learning curve
- Capture information in the moment
- A picture is worth a thousand words
- See reminders when you set alarms



## Creating a note

### [ ! ] Before You Begin

Make sure **full-screen writing is turned off**. You cannot create or edit notes in Note Pad when full-screen writing is on.

### \* Tip

You can change the color of the pen and paper (background). From the Note Pad list screen, **open the Options menu**, select Preferences, and then tap Colors.

### \* Tip

Tap the pen selector to change the pen width or to select the eraser.

### + Did You Know?

Set an alarm for a note to use it as a reminder.

1

**Go to Applications** and select Note Pad .

2

Create a note:

- Use the stylus to write your note directly on the handheld screen.
- Select the time at the top of the screen and enter a title using **Graffiti® 2 writing** or the **onscreen keyboard**.
- Select Done.

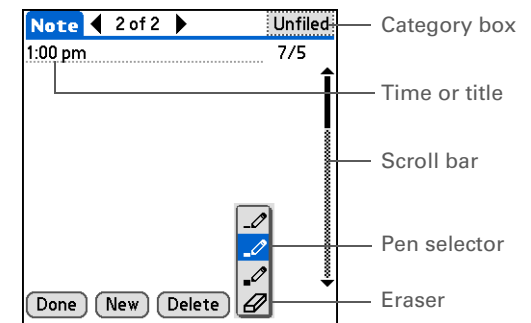

Done

That's it. Your handheld automatically saves the note. Make sure you have a current backup. **Synchronize** often.

## Viewing and editing a note

## \* Tip

Sort the Note Pad list alphabetically, by date, or manually. **Open the Options menu**, select Preferences, and then select the Sort by pick list.

If you sort manually, you can rearrange the list by dragging notes to another position in the list.

1

**Go to Applications** and select Note Pad .

2

Open the note:

- a. Select Done to display the Note Pad list.
- b. Select the note you want to view or edit.

Note Pad		All
1. Welcome to Note Pad	7/2	
2. Groceries	7/5	
3. Bob	7/5	
4. Flowers	7/5	
5. Bank	7/5	

New

→

Note ◀ 2 of 2 ▶
Errands: 7/5

Groceries

Milk

Eggs

Bread

Lettuce

Done
New
Delete

3

Read or edit the note, and then select Done.

 Done

Tungsten™ T5 Handheld

89

## Beyond the basics

Click the link to the left to go to the *User Guide* on the web and learn about these related topics:

Note Pad	Setting alarms when you use notes as reminders
Categories	Organizing notes by arranging them into categories and sorting them
Privacy	Keeping notes private by turning on security options
Sharing	<ul style="list-style-type: none"><li>• Beaming notes to other Palm Powered™ devices</li><li>• Sending notes to other Bluetooth® devices by using Bluetooth wireless technology on your handheld</li></ul>
Email	Sending notes as attachments to email messages

### User Guide

For everything you need to know about your handheld—all that's in this guide, and much more—go to [www.palmOne.com/tungstent5-userguide](http://www.palmOne.com/tungstent5-userguide).

### My Handheld

Make your handheld uniquely yours. For great tips, software, accessories, and more, visit [www.palmOne.com/mytungstent5](http://www.palmOne.com/mytungstent5).

### Support

If you're having problems with Note Pad or with anything else on your handheld, go to [www.palmOne.com/support/tungstent5](http://www.palmOne.com/support/tungstent5).

# Making Wireless Connections

## In this chapter

[What can I do with the built-in Bluetooth wireless technology?](#)

[What types of connections can I make?](#)

[Entering basic Bluetooth settings](#)

[Setting up a phone connection](#)

[Accessing email and the web wirelessly](#)

[Setting up a connection for wireless synchronization](#)

[Beyond the basics](#)

Your handheld helps keep your world organized by storing contact information and documents, recording appointments, and so on. Now, your handheld can actually connect you to the world—wirelessly, using Bluetooth® wireless technology. Need to make a phone call? Tap the number in Contacts, and your mobile phone begins dialing. How about browsing the web or sending an email message from your handheld—without a cable?

Your handheld's built-in Bluetooth functionality helps you easily set up wireless connections to a number of devices so you can enjoy the convenience of cable-free connectivity.



## Benefits

- Connect to your Bluetooth phone to send text or email messages or access the web
- Reduce cable clutter by synchronizing wirelessly
- Connect to other devices to share files wirelessly

## What can I do with the built-in Bluetooth wireless technology?

### » Key Term

**Bluetooth** Technology that enables devices such as handhelds, mobile phones, and computers to connect wirelessly to each other.

### [ ! ] Before You Begin

Any device you connect to must also be a Bluetooth device. Check the user guide for your device to enable the Bluetooth features.

#### **Connect to your Bluetooth phone to send text or email messages or to access the web.**

Whether you access the Internet or send text or email messages once a week or constantly throughout the day, wireless connectivity means that you can go online or share files anytime by connecting via your mobile phone or your laptop connected to the Internet.

**Reduce cable clutter by synchronizing wirelessly.** Imagine your desk and workstation without cable clutter. Bluetooth wireless technology on your handheld replaces many of the connecting cables with a wireless connection for tasks such as synchronizing.

**Connect to other devices to share files wirelessly.** Wouldn't it be great if you could transfer files such as photos wirelessly or print wirelessly on a Bluetooth printer? Use the built-in Bluetooth wireless technology to set up connections to devices within approximately 30 feet of your handheld.

## What types of connections can I make?

With Bluetooth wireless technology, you can make connections using the following types of devices:

- To browse the Internet or access your email account, link through your desktop computer's network connection or establish a connection to a Bluetooth LAN Access Point.
- To access the Internet or an email account, connect to your mobile phone. To use a mobile phone, you must dial your ISP or sign up for an account with a high-speed wireless carrier.
- To send and receive text messages, connect to your mobile phone.
- To synchronize your handheld with your computer wirelessly, connect to your computer.
- To share files with another Bluetooth device such as a handheld or printer, form a trusted pair with that device.

## Entering basic Bluetooth settings

### \* Tip

You can also open the Bluetooth settings screen by selecting Bluetooth controls on the **status bar** and then selecting Prefs from the screen that appears.

### » Key Term

**Discoverable** Setting that allows other devices to find and connect with your handheld using Bluetooth technology. If your handheld is not discoverable, other devices cannot find it to make a connection. Your handheld must be powered on in order to be discoverable.

**NOTE** The input area always appears when you are using any of the Bluetooth screens. You cannot turn off the input area when working with Bluetooth technology.

1

**Go to Favorites** and select Bluetooth .

2

Enter the basic Bluetooth settings:

- a. Select On.
- b. Tap the Device Name field and enter a name for your handheld. This is the name other Bluetooth devices see when they connect to your handheld. By default it is the username you use during synchronization, but you can change it.
- c. Select the Discoverable pick list and select Yes or No.

↓ Done

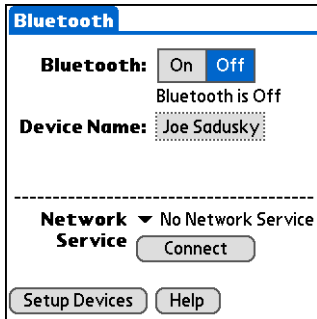

## Setting up a phone connection

\* **Tip**

If you receive a message that your phone is not ready to accept a connection, check to make sure that your phone is prepared to make a Bluetooth connection. See the instructions included with your phone.

[ ! ] **IMPORTANT** To set up a phone connection, you must have a GSM or GPRS mobile phone enabled with data services.

**1**

**Go to Favorites** and select Bluetooth .

**2**

Select Setup Devices, select Phone Setup, select Setup Connection, and then select Next.

**3**

Select the phone you want to connect to:

- a. Select the Manufacturer and Model pick lists, select the correct entries for your phone, and then select Next.
- b. The Connection Setup screen displays all Bluetooth phones within range. Select the phone you want, select Next, and then select Next again.
- c. If the phone you want does not appear on the Connection Setup screen, select Find More. If the phone still does not appear, run the **Phone Link Updater** application (Windows only) and then go to step 4.

**NOTE** For Mac computers, if the phone does not appear on the list, go to [www.palmone.com/us/support/downloads/phonelink.html](http://www.palmone.com/us/support/downloads/phonelink.html) to download the driver for your phone, and then go to step 4.

↘ **Continued**

## » Key Term

**Passkey** Like a password, the passkey is a security measure. Connections can happen only between your handheld and a device that has the same passkey. For example, to connect to your mobile phone, you need to enter the same passkey on your handheld and on your phone.

## » Key Term

**Trusted pair** Two devices—for example, your handheld and your mobile phone—that can connect to each other because each device can find the same passkey on the other device. Once you form a trusted pair with a device, you do not need to enter a passkey to connect with that device again.

**4**

Enter a passkey:

- a. Enter a passkey number. This can be any number you choose; it does not, for example, have to be a password you use to access a network or an email account.

[ ! ] **IMPORTANT** You must enter the same passkey on your handheld and your mobile phone in order to connect to your phone.

- b. Select OK.

**5**

Finish phone connection setup and begin network setup:

- a. Select Done, and then select Yes.

**NOTE** If you want to use your phone connection only to dial phone numbers from your handheld or send text messages, select Done and then select No. You have finished setup.

- b. Select Next.

**6**

Begin network setup:

- a. Select the pick list, select Yes or No, and then select Next. If you select Yes, go to step 7. If you select No, go to step 8.

↘ **Continued**



**» Key Term**

**GPRS** Acronym for General Packet Radio Service, a method of sending information wirelessly at high speeds. Select Yes in step 6 only if you have a GPRS account for your mobile phone.

**\* Tip**

Contact your ISP (for example, AOL or Earthlink) if you are not sure about any of the items to enter in step 8.

**7**

If you selected Yes in step 6:

- a. Select the pick lists and select the correct information for your cellular carrier.
- b. Select Next, and then select Done.

**8**

If you selected No in step 6:

- a. Select Next.
- b. Enter the phone number you use to dial in to your Internet service provider and the username for your dial-up account.
- c. Tap the Password box, enter your account password, and select OK. This is the password you use to access your dial-up account; it is not your passkey.
- d. Select Next, and then select Done.

**↓ Done**

**See the next procedure for steps on using your phone connection to browse the web or send and receive email messages.**

## Accessing email and the web wirelessly

After you set up a connection with a mobile phone, you can send and receive email or browse the web wirelessly using this connection.

**NOTE** Bluetooth functionality must be on if you want to use wireless features. You must also **set up an email account** on your handheld before you can send or receive email messages.

+ **Did You Know?**  
You can select Bluetooth controls on the status bar to quickly check Bluetooth status and make a connection from any application on your handheld.

**1**

Open the **email application** or the **web browser**.

**2**

Verify Bluetooth status:

- Select Bluetooth controls  on the status bar.
- Make sure On is selected.

↘ **Continued**

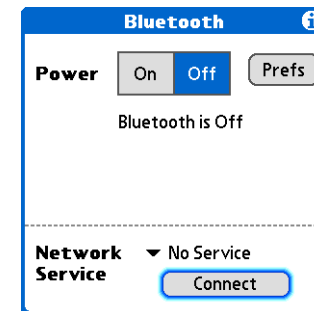

## » Key Term

**Service** Way of connecting to a mobile phone to send information wirelessly, for example, through a high-speed (GPRS) carrier or a dial-up account with an Internet service provider (ISP).

## \* Tip

When you **enter a URL** in the web browser or select **Get and Send** in the VersaMail® application, a connection automatically initiates with the last used service.

## 3

Connect to your phone:

- a. Select Prefs from the Bluetooth status screen.
- b. On the Bluetooth preferences screen, select the Network Service pick list and select the service that you want to use to connect to the Internet. If you **set up a phone connection**, the name of the service you configured is listed.
- c. Select Connect.



Done

You are now ready to **send and receive email messages** or to **browse the web**.

## Setting up a connection for wireless synchronization

### WINDOWS ONLY

\* **Tip**  
To open HotSync® Manager on your computer in step 2 of the onscreen instructions (see procedure step 3b, below), click the HotSync Manager icon on the taskbar in the lower-right corner of your computer screen.

\* **Tip**  
After the first time you set up a connection and wirelessly synchronize with a computer, you can synchronize with that computer at any time by choosing its device name from the Service pick list and tapping Connect.

- 1 **Go to Favorites** and select Bluetooth .
- 2 Select Setup Devices, select PC Setup, select Bluetooth HotSync, and then select Next.
 

**Setup Devices**

Phone Setup  
Messaging, Dial from Contacts, Internet connectivity.

PC Setup  
Browse the Web, Check Email, HotSync wirelessly.

LAN Setup  
Browse the Web, check Email.

Done Trusted Devices

→

**PC Setup**

**To set up a connection or wireless HotSync, tap below:**

PC Connection  
Set up a wireless connection and data service to your PC.

Bluetooth HotSync  
Set up your PC to synchronize using Bluetooth.

Done
- 3 Set up a connection for wireless synchronization:
  - a. Follow the onscreen instructions for steps 1–3, selecting Next after each step.
  - b. Select Launch HotSync Manager in step 4.
  - c. Select HotSync  to synchronize your handheld with your computer.

↓ Done

## MAC ONLY

1

**Go to Applications** and select **Prefs** .

2

Open the Edit Connection screen:

- a. From the Communications Preferences list, select Connection.
- b. Tap New.

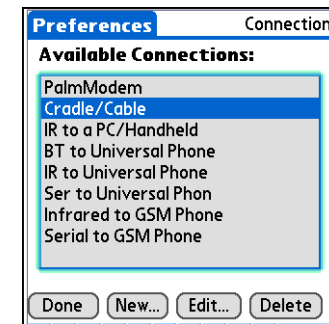

3

Set up the connection to your computer:

- a. Enter a name for the connection, such as BT to Mac.
- b. Select the Connect to pick list and select PC.
- c. Select the Via pick list and select Bluetooth.

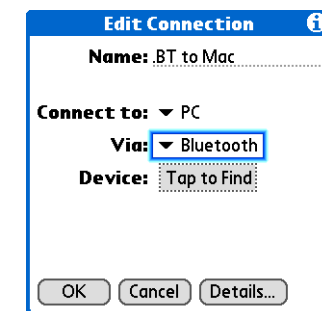

↘ Continued

**\* Tip**

Just as it is safer to use different personal identification numbers (PINs) for different bank accounts, your passkeys are more secure if you use a different passkey for each device with which you want to connect—one passkey for a connection to a phone, a different one for a connection to a computer, and so on. Just remember that you must enter the same passkey on your handheld and on the device with which you want to connect.

**Cont'd.**

d. Make sure the computer is ready to accept a Bluetooth connection.

**NOTE** See the documentation included with the computer for information on how to prepare it to accept a Bluetooth connection. The documentation might refer to a Bluetooth connection as a Bluetooth pairing or a Bluetooth link.

e. Select the Device box.

**4**

Select the computer:

- a. When the Discovery Results screen appears, select your computer. If your computer does not appear on the list, select Find More.
- b. Select OK.

**5**

**[ & ] OPTIONAL** If prompted, enter a passkey:

- a. Enter a passkey number. This can be any number you choose; it does not, for example, have to be a password you use to access a network or an email account.



**[ ! ] IMPORTANT** You must enter the same passkey on your handheld and your computer in order to wirelessly synchronize with your computer.

- b. Select OK.

↘ **Continued**

**6**

Synchronize your handheld with your computer:

- a. **Go to Applications** and select HotSync .
- b. Make sure Local is selected, and select the connection you created in step 3 from the pick list.
- c. Select HotSync .

↓ Done

## Beyond the basics

Click the link to the left to go to the *User Guide* on the web and learn about these related topics:

### User Guide

For everything you need to know about your handheld—all that's in this guide, and much more—go to [www.palmOne.com/tungstent5-userguide](http://www.palmOne.com/tungstent5-userguide).

### My Handheld

Make your handheld uniquely yours. For great tips, software, accessories, and more, visit [www.palmOne.com/mytungstent5](http://www.palmOne.com/mytungstent5).

### Support

If you're having problems with built-in Bluetooth technology or with anything else on your handheld, go to [www.palmOne.com/support/tungstent5](http://www.palmOne.com/support/tungstent5).

### Connecting

- Connecting to the Internet through your Bluetooth desktop computer to access the web wirelessly
- Connecting with a network using a Bluetooth Access Point to access the Internet and send and receive email messages
- Connecting to your Bluetooth phone by means of the infrared port on your handheld
- Using Phone Link Updater to download the most recent phone drivers and list of supported GSM/GPRS carriers
- Setting the Bluetooth options on your handheld to allow your handheld to wake up and receive an incoming connection request when turned off



# Sending and Receiving Email Messages

## In this chapter

[Setting up an account](#)

[Getting and reading email](#)

[Sending an email message](#)

[Working with attachments](#)

[Beyond the basics](#)

If you already know how efficient email is for staying in touch with personal and business contacts, VersaMail® personal email software brings you a new level of convenience: email on the go. If you are a new email user, you will enjoy the ease and speed of communicating with friends, family, and colleagues anywhere you can make an Internet connection.

You can attach files such as photos to email messages, as well as Microsoft Word, Excel, or PowerPoint files—or receive any of these file types as attachments to view and edit at your convenience. You can also synchronize email messages on your handheld with email on your desktop computer.



## Benefits

- Access email on the go
- Send and receive photos, sound files, Word and Excel files, and more
- Save messages from your computer to view at a convenient time

## Setting up an account

### » Key Term

**Protocol** Settings your email provider uses to receive email messages. Most providers use the Post Office Protocol (POP); a few use the Internet Message Access Protocol (IMAP).

### \* Tip

If your email provider appears on the Mail Service pick list, you don't need to select a protocol. The correct protocol is automatically displayed.

**1**

**Go to Favorites** and select VersaMail .

**2**

Open the Account Setup screen:

- Select Menu  on the status bar, select Accounts, and then select Account Setup.
- Select New.

**3**

Enter the basic account information:

- In the Account Name field, enter a descriptive name.

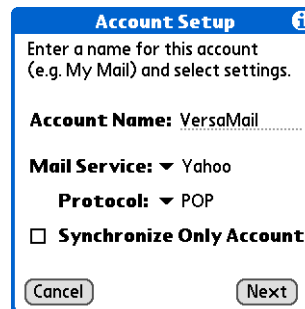

**Account Setup** ⓘ

Enter a name for this account  
(e.g. My Mail) and select settings.

**Account Name:** VersaMail.....

**Mail Service:** ▼ Yahoo

**Protocol:** ▼ POP

**Synchronize Only Account**

Cancel Next

↘ Continued

\* **Tip**

Your username is usually the part of your email address appearing before the @ symbol, not your entire email address. Check with your ISP if you are not sure what username to enter.

+ **Did You Know?**

Your incoming mail server is also called your POP or IMAP server; your outgoing mail server is also called your Simple Mail Transfer Protocol (SMTP) server.

\* **Tip**

If you checked the Synchronize Only Account box in step 3, you need to **configure this account on your computer** before you can send or get email messages.

**Cont'd.**

- b. Select the Mail Service pick list, and then select your email provider. Select Other if your provider is not listed.
- c. If you chose Other, select the Protocol pick list, and then select POP or IMAP.
- d. Check the box if you intend *only* to synchronize email for this account on your handheld with a mail program on your computer such as Microsoft Outlook, Outlook Express, or Lotus Notes. If you intend to *ever* send or receive email for this account wirelessly from your handheld (even if you will also synchronize email), leave the box unchecked.
- e. Select Next.

**4**

Enter the account username and password:

- a. Enter the username you use to access your email.
- b. Select the Password box, enter your email account password, and then select OK.
- c. Select Next.

↘ **Continued**

\* **Tip**  
Check with your email service provider for the names of your incoming and outgoing mail servers.

**5**

Enter your email address and mail server info:

**NOTE** If you chose a common email provider from the Mail Services pick list on the Account Setup screen, this screen is already filled in.

- a. Enter your email address.
- b. Enter the names of your mail servers.
- c. Select Next.

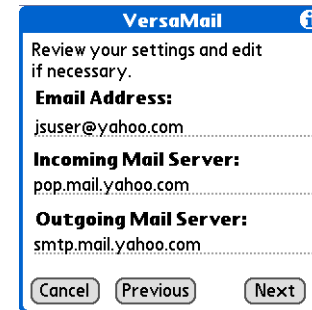

The screenshot shows a dialog box titled "VersaMail" with an information icon. The text inside reads: "Review your settings and edit if necessary." Below this, there are three sections: "Email Address:" with the value "jsuser@yahoo.com", "Incoming Mail Server:" with the value "pop.mail.yahoo.com", and "Outgoing Mail Server:" with the value "smtp.mail.yahoo.com". At the bottom, there are three buttons: "Cancel", "Previous", and "Next".

**6**

Select Done.

↓ Done

## Getting and reading email

### \* Tip



If you checked the Synchronize Only Account box, you must **synchronize your handheld with your computer** to download messages to your handheld.

### + Did You Know?

You can set up your handheld to **automatically check for and download** new email messages.

### \* Tip

If you select Messages, the first 5KB of each message is downloaded. You can **change the maximum size** for downloaded messages in the VersaMail preferences.

- 1 **Go to Favorites** and select VersaMail .
- 2 Choose whether to get message subjects only or full messages:
  - a. Select Menu  on the status bar, select Accounts, and then select the account you want.
  - b. Select Get Mail or Get & Send.
 

New
Get Mail
Display

➔

Get Mail Options i

Subjects Only
Messages

OK
Cancel
Details...
  - c. In the Get Mail Options dialog box, select Subjects Only to download subjects only, or select Messages to download entire messages.
  - d. Select OK.
  - e. Select OK again if prompted.
- 3 In the Inbox, select the message to read it.
 

 Done

## Sending an email message

### \* Tip

If you checked the Synchronize Only Account box, you must **synchronize** so that messages you compose on your handheld can be sent out through your computer's email application.

### + Did You Know?

You can set up your handheld to **automatically try resending** any messages that are not sent correctly the first time.

### + Did You Know?

When you put addresses in the copies (cc:) field, they are visible to all other recipients. Addresses in the blind copies (bcc:) field are hidden from all other recipients.

1

**Go to Favorites** and select VersaMail .

2

Send email:

- Select Menu  on the status bar, select Accounts, and then select the account you want.
- Select New.

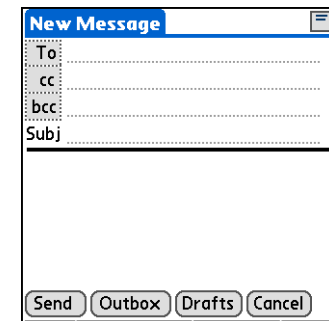
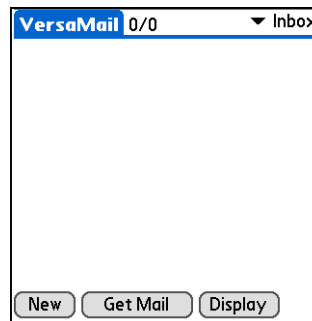

- In the To field, enter the recipient's email address. For multiple recipients, type a semicolon (;) between recipient names.
- In the Subj field, enter the subject of your email. In the area below the Subj line, enter the text of your email.
- Select Send.

↓ Done

## Working with attachments

You can easily download, view, save, and send attachments with email messages. Among the attachment types you can download and work with are Word docs, Excel spreadsheets, web pages, photos and videos, contacts, appointments, and tasks.

### Downloading an attachment to your handheld

In the message list, a paper clip on a message's envelope icon indicates that the message has an attachment that has been downloaded. You can view, edit, install, or save an attached file, depending on the file type.

**+ Did You Know?**  
When you see both a red paper clip icon and the More button in the Message screen, that means that some attachments to this message were downloaded, but others remain to be downloaded.

**\* Tip**  
If you choose to get messages by subject only, tap More for each downloaded message to view the body of the email message plus any attachments, up to the maximum message size.

1

In the Inbox, tap the message with the attachment.

✉ Continued

Paper clip —

### + Did You Know?

The maximum message size you can download is 60KB for the body text and approximately 5MB total, including attachments. If an attachment is too large, it cannot be downloaded to the handheld. You can download a maximum of ten attachments for any received messages, regardless of message size.

### \* Tip

Because large messages can take up a lot of space on the internal drive, the VersaMail application displays the size and asks if you want to continue downloading any message that exceeds your maximum message size, up to a total size of 5MB. Select Yes to download the message and any attachments.

## 2

Open the attachment(s):

- a. Tap the red paper clip icon in the upper-right corner.
- b. Select the attachment you want, and then select View, Install, or Unzip, depending on the attachment file type. Or select Save to save the attachment to your handheld's **internal drive** or to an **expansion card**. If you select View and the Viewer pick list appears, select the application you want to use to view the attachment.

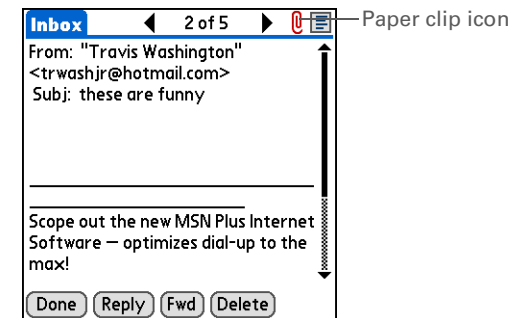

## 3

When you finish with the attachment, select Done to return to the Attachments dialog box. If there is no Done button, press Home  and select VersaMail to return to the Inbox of the account you were in.

↓ Done



## Attaching a file from your handheld

You can attach files on your handheld to email messages you send. For example, you can attach photos or videos, Word documents, Excel spreadsheets, and entries from Contacts or Calendar.

- + Did You Know?**  
The maximum size message you can send is 60KB for the body text and approximately 5MB of total data for any attachments. The maximum number of attachments for any e-mail message is ten, regardless of the attachments' total size.

- \* Tip**  
Repeat step 2 to attach more than one file to a message. To remove an attachment, select the file in the Attachments box, and then tap Delete.

### 1

Open the Attachments screen:

- On the message screen, select Menu  on the status bar.
- Select Options, and then select Attachment.

### 2

Attach the file:

- Select the Type pick list, and then select the file type. Or select to browse files on your handheld's internal drive or on an expansion card.

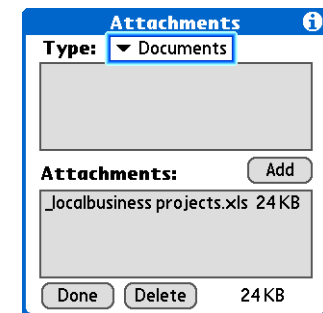
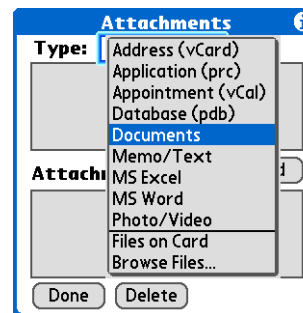

- Select the file that you want to attach, select Add or Attach, and then select Done.

↓ Done

**User Guide**

For everything you need to know about your handheld—all that's in this guide, and much more—go to [www.palmOne.com/tungstent5-userguide](http://www.palmOne.com/tungstent5-userguide).

**My Handheld**

Make your handheld uniquely yours. For great tips, software, accessories, and more, visit [www.palmOne.com/mytungstent5](http://www.palmOne.com/mytungstent5).

**Support**

If you're having problems with the VersaMail application or with anything else on your handheld, go to [www.palmOne.com/support/tungstent5](http://www.palmOne.com/support/tungstent5).

## Beyond the basics

Click the link to the left to go to the *User Guide* on the web and learn about these related topics:

- |             |  |
|-------------|--|
| Email       | <ul style="list-style-type: none"><li>• Using the VersaMail application with Microsoft Outlook on your computer</li><li>• Setting basic email preferences such as changing the maximum message size, adding a signature to outgoing messages, and downloading files attached to email messages</li><li>• Using a virtual private network (VPN) to get and send email over your company's network</li><li>• Editing and deleting an email account</li><li>• Automatically retrieving email on your handheld</li><li>• Automatically trying to resend messages that weren't sent the first time</li><li>• Customizing your Inbox display options such as message summary view and font size and colors for read and unread mail</li><li>• Synchronizing email messages on your handheld with email messages on your computer</li></ul> |
| Customizing | Setting preferences for connecting to a network  |

# Sending and Receiving Text Messages

## In this chapter

[Sending a text message](#)

[Viewing a text message](#)

[Beyond the basics](#)

If you need to get a short message to a friend or coworker fast, send a text message from your handheld via your mobile phone (GSM phone required; sold separately) to their mobile phone. Messaging is a popular way for people to stay connected using the text messaging features of their mobile phone.



## Benefits

- Enjoy quick communication
- Use text messaging to chat with friends

## Sending a text message

[ ! ] **Before You Begin**

Before you can send and receive text messages, you must **set up a phone connection** on your handheld to send and receive information wirelessly.

» **Key Term**

**SMS** Abbreviation for Short Message Service. More commonly known as text messages, SMS messages can be received by most mobile phones.

1

Go to Applications and select SMS .

2

Send a text message:

a. Select New.

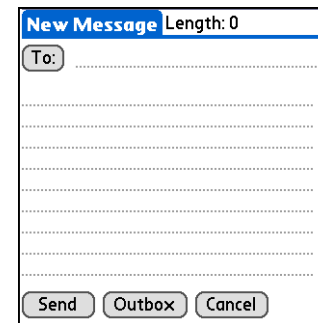

- b. Select To. Select the recipient's name if it appears on the Mobile Number Lookup list, and then select Add. If the name does not appear on the list, select Cancel and enter the recipient's mobile phone number on the To line.
- c. In the area below the To line, enter the text of your message.
- d. Select Send.

 Done

## Viewing a text message

- \* **Tip**  
Use the buttons at the bottom of the message screen to reply to or delete a message after you open it.

**1** Go to Applications and select SMS .

**2** Select Send & Check.

**3** Read a message:

a. Select the message to open it.

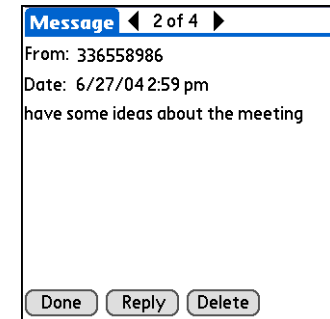
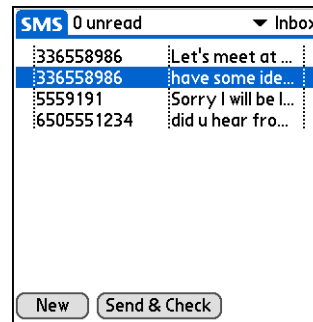

b. Read the message, and then select Done.

 Done

## Beyond the basics

Click the link to the left to go to the *User Guide* on the web and learn about these related topics:

### SMS

- Replying to and deleting messages you receive
- Setting preferences for receiving messages
- Hearing an alert when you receive a message

### Customizing

Setting preferences for connecting to a network

### User Guide

For everything you need to know about your handheld—all that's in this guide, and much more—go to [www.palmOne.com/tungstent5-userguide](http://www.palmOne.com/tungstent5-userguide).

### My Handheld

Make your handheld uniquely yours. For great tips, software, accessories, and more, visit [www.palmOne.com/mytungstent5](http://www.palmOne.com/mytungstent5).

### Support

If you're having problems with SMS or with anything else on your handheld, go to [www.palmOne.com/support/tungstent5](http://www.palmOne.com/support/tungstent5).

# Browsing the Web

## In this chapter

[Accessing a web page](#)

[Beyond the basics](#)

You use the web for so many things: checking email, finding driving directions, getting news, buying gifts. Now you can take the web with you almost anywhere you go. Make an Internet connection through your mobile phone, and the web browser opens the entire web to you.



## Benefits

- Carry the web with you
- View web pages in a handheld-friendly format
- Store pages for offline viewing

## Accessing a web page

### [ ! ] Before You Begin

To browse the web, you must **set up a connection to the Internet** from your handheld.

### » Key Term

**URL** Stands for “uniform resource locator,” the technical name for a web address. For example, the URL for Yahoo! is `http://www.yahoo.com`.

1

**Go to Applications** and select Web .

2

Go to the web page you want to view:

a. Select Go to Web Page .

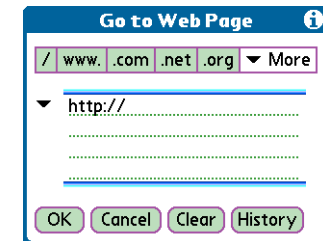
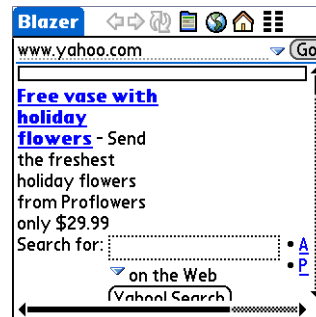

- b. Enter the address of the web page you want to visit. Use the buttons in the Go to Web Page dialog box for quick entry of characters commonly used in web addresses. If you have previously visited a web page, the web browser recognizes the address when you begin entering it and automatically completes it.
- c. Select OK.

 Done



### User Guide

For everything you need to know about your handheld—all that's in this guide, and much more—go to [www.palmOne.com/tungstent5-userguide](http://www.palmOne.com/tungstent5-userguide).

### My Handheld

Make your handheld uniquely yours. For great tips, software, accessories, and more, visit [www.palmOne.com/mytungstent5](http://www.palmOne.com/mytungstent5).

### Support

If you're having problems with Web Pro or with anything else on your handheld, go to [www.palmOne.com/support/tungstent5](http://www.palmOne.com/support/tungstent5).

## Beyond the basics

Click the link to the left to go to the *User Guide* on the web and learn about these related topics:

### Web

- Refreshing a page to see updated information
- Using a bookmark for quick access to your favorite web pages
- Returning to a web page you just visited or to your home page
- Downloading a file from a web page
- Changing your start and home pages

### Customizing

Setting preferences for connecting to a network

# Expanding Your Handheld

## In this chapter

[What type of expansion cards can I use?](#)

[How can expansion cards help me?](#)

[Inserting an expansion card](#)

[Removing an expansion card](#)

[Beyond the basics](#)

A Chinese proverb says, “Life just gives you time and space; it's up to you to fill it.” But doesn't it always seem that no matter how much space you have, you still need more?

Expansion cards (sold separately) provide a compact and limitless answer to the storage dilemma. When one card becomes full, simply use another card. Also use expansion cards to install and run cool games and other types of software, from dictionaries to travel guides, on your handheld.



## Benefits

- Back up info
- Add more games and other software
- Add accessories
- Store all your info

**» Key Term**

**SDIO** An acronym for Secure Digital input/output.

**\* Tip**

Looking for a handy way to carry your expansion cards? You can purchase a variety of carrying cases. Visit [www.palmOne.com/mytungstent5](http://www.palmOne.com/mytungstent5) and click the Accessories link.

## What type of expansion cards can I use?

Your handheld is compatible with SDIO, SD, and MultiMediaCard expansion cards. SDIO expansion cards let you add accessories to your handheld. SD and MultiMediaCard expansion cards let you store information and applications.

## How can expansion cards help me?

**Back up info.** Make a copy of your important information for safekeeping in case your handheld becomes damaged or is stolen.

**Add games and other software.** Purchase popular games, dictionaries, travel guides, and more. To check out the variety of expansion cards available for your handheld, visit [www.palmOne.com/mytungstent5](http://www.palmOne.com/mytungstent5) and click the Accessories link.

**Add accessories.** Attach SDIO accessories, such as a presentation module, to your handheld.

**Store all your info.** Never worry about running out of space on your handheld. Purchase as many expansion cards as you need to store your music, photos, videos, and other information. Expansion cards come in a variety of capacities, and they're very small, easy to store, and affordably priced.

## Removing an expansion card

**NOTE** Your handheld comes with a dummy card inserted in the expansion card slot. You must remove this card before you can put a real card in the slot.

**\* Tip**  
To prevent damaging the card and the info on it, always wait for your handheld to finish writing to the expansion card before you remove the card from the slot.

**1**

Push lightly against the card with your thumb until you hear the confirmation tone.

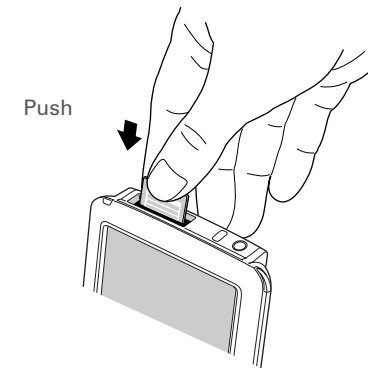
**2**

Slide the card out of the expansion slot.

↓ Done

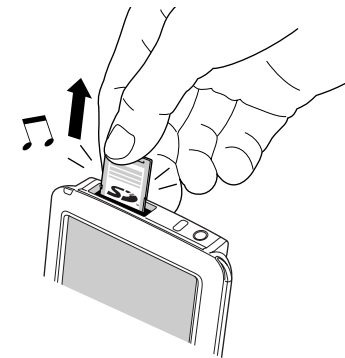

## Inserting an expansion card

**1**

Insert the card into the expansion slot with the label side facing the front of the handheld.

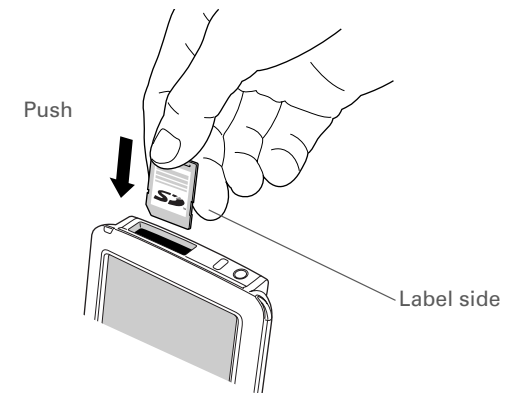
**2**

Push the card in with your thumb until you feel the card “click” in place and hear the confirmation tone.

**NOTE** No confirmation tone? Check the [Sounds & Alerts Preferences](#) to make sure the System Sound setting is turned on.

↓ Done

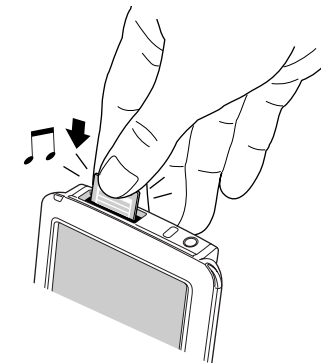

## Beyond the basics

Click the link to the left to go to the *User Guide* on the web and learn about these related topics:

### User Guide

For everything you need to know about your handheld—all that's in this guide, and much more—go to [www.palmOne.com/tungstent5-userguide](http://www.palmOne.com/tungstent5-userguide).

### My Handheld

Make your handheld uniquely yours. For great tips, software, accessories, and more, visit [www.palmOne.com/mytungstent5](http://www.palmOne.com/mytungstent5).

### Support

If you're having problems with expansion cards or with anything else on your handheld, go to [www.palmOne.com/support/tungstent5](http://www.palmOne.com/support/tungstent5).

#### Expansion Cards

- Opening applications that are stored on expansion cards
- Copying applications between your handheld and an expansion card
- Deleting applications and other files from an expansion card
- Reviewing information about the contents of an expansion card using the Card Info application
- Naming an expansion card so you can easily identify its contents

#### Opening

Browse the contents of an expansion card using Files

#### Installing and Removing

Adding applications from your computer to an expansion card, and installing other files such as photos, videos, or music

#### Sharing

- Exchanging applications and information with other Palm Powered™ devices by exchanging cards or beaming items between handhelds
- Sending applications and information to other Bluetooth® devices by using Bluetooth technology on your handheld

# Customizing Your Handheld

## In this chapter

[Setting the date and time](#)

[Preventing your handheld from turning on by accident](#)

[Changing the screen fonts](#)

[Changing the background of your screen](#)

[Correcting problems with tapping](#)

[Selecting sound settings](#)

[Changing entries in Favorites](#)

[Beyond the basics](#)

Although customizing your handheld is optional, it's like changing the preset radio stations in your car. Since you're probably not driving around with the dealer's preset radio stations, why not personalize your handheld, too?

You can easily customize the sound levels, fonts, and screen colors on your handheld by using preferences and menus. And preference settings can help extend the life of your handheld's battery.



## Benefits

- Access applications quickly
- Conserve power
- Enjoy your handheld more
- Make your screen easy to read

## Setting the date and time

- \* **Tip**  
You can rename the location to the city where you live. Tap the Name field, and then modify the location name.

You can set the current date and time based on your location. These settings are used by all the applications on your handheld that require a date, time, or location.

### 1

Open Date & Time Preferences:

- Go to Applications.**
- Select Prefs .
- Select Date & Time.

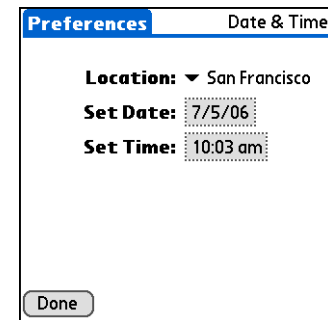

Preferences Date & Time

Location: ▼ San Francisco

Set Date: 7/5/06

Set Time: 10:03 am

Done

### 2

Select the location:

- Tap the Location pick list, and select a city in your time zone. No nearby city? Select Edit List and do steps b–c.
- Tap Add.
- Select a city in your time zone, and then select OK. Select OK again, and then select Done.

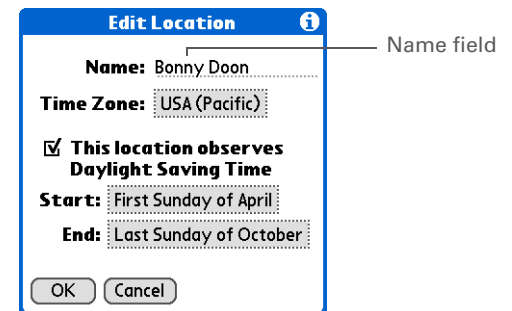

Edit Location

Name: Bonny Doon

Time Zone: USA (Pacific)

This location observes Daylight Saving Time

Start: First Sunday of April

End: Last Sunday of October

OK Cancel

↘ Continued



**3**

Set the date:

- Tap the Set Date box.
- Tap the arrows to select the current year.
- Tap the current month.
- Tap the current date.

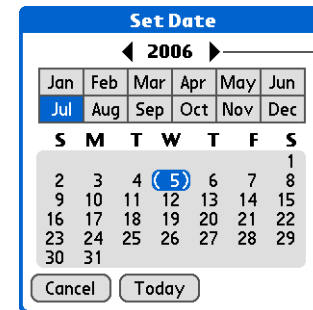

Year  
arrows

**4**

Set the time:

- Tap the Set Time box.
- Tap the hour and minute boxes, and then tap the arrows to change them.
- Tap AM or PM, and then select OK.

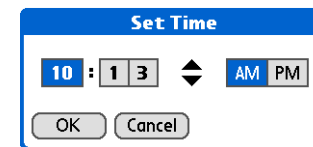
**5**

Select Done.

↓ Done

## Preventing your handheld from turning on by accident

Does your handheld turn itself on accidentally in your briefcase, pocket, or purse? You can lock the buttons on the front of your handheld so you prevent this from happening and don't drain the battery.

\* **Tip**  
When Keyguard is on, your handheld does not respond when you press the buttons on the front of your handheld. To use your handheld again, press the power button and then tap Deactivate Keyguard.

+ **Did You Know?**  
You can use Owner Preferences to enter your name, address, and phone number. If you also turn on Security settings, your Owner info appears when you turn on your handheld. This could help someone contact you if you ever lose your handheld.

### 1

Open Keyguard Preferences:

- a. **Go to Applications.**
- b. Select Prefs .
- c. Select Keyguard.

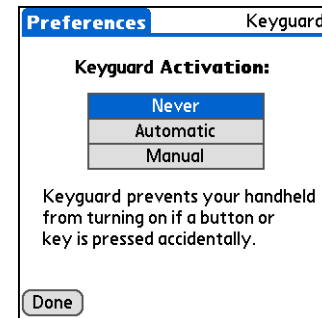

### 2

Select one of these settings, and then select Done.

**Never** Keyguard always remains off.

**Automatic** Keyguard turns on automatically when you turn off your handheld or when your handheld goes to sleep.

**Manual** Keyguard turns on when you press and hold the power button until the system sound confirms that Keyguard is on.

↓ Done

## Changing the screen fonts

In many applications, you can change the font style to make text easier to read. There are four font styles available in applications that let you change the font style.

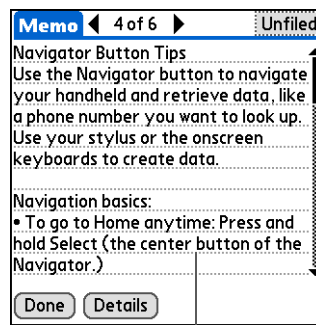

Small font

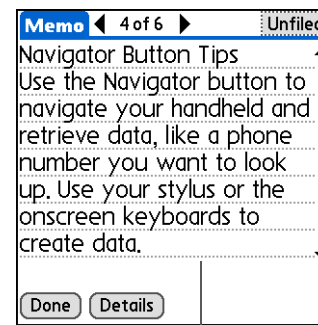

Large font

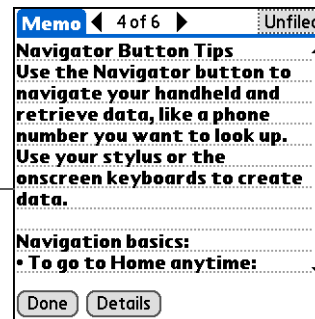

Small bold font

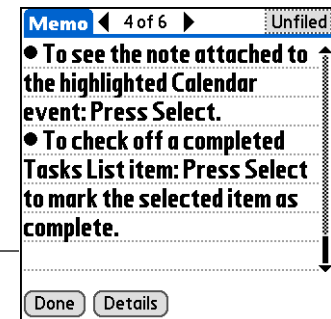

Large bold font

**1**

Open the Select Font dialog box:

- a. **Open an application.**
- b. Select Menu  on the status bar.
- c. Select Options, and then select Font.

**2**

Tap the font style you want to use, and then select OK.

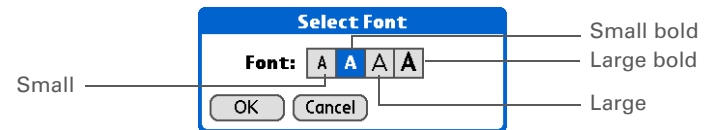



↓ Done

## Changing the background of your screen

Use your favorite photos as the background for the Favorites and Applications Views and the Agenda View in Calendar. Choose the same photo for all screens or make them different.

### 1

Open the Display Options dialog box:

- a. Press the Home  button once for Favorites, twice for Applications. Or, press the Calendar  button for Agenda View.
- b. Select Menu  on the status bar.
- c. Select Options, and then select Display Options. For Favorites, select Options, and then select Preferences.

### 2

Select a photo:

- a. Check the Background box.
- b. Tap the photo thumbnail and select a photo.
- c. In Favorites and Applications, adjust the fade setting so that text and icons are easy to see against the photo.
- d. Select OK.

 Done

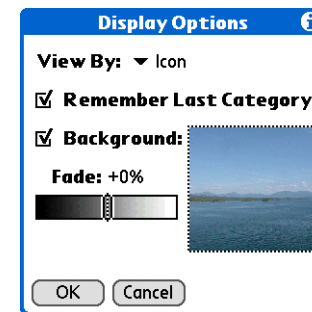

**NOTE** The screen for selecting a background photo appears differently in each of the three applications. The Applications Display Options screen is shown here.

## Correcting problems with tapping

Is your screen not responding to taps? Are you getting unexpected results when you tap? For example, when you tap the number keyboard icon, does the Bluetooth dialog box open instead? If this happens, it's time to align the screen.

» **Key Term**  
**Touchscreen** Another name for your handheld's screen and its internal circuitry.

\* **Tip**  
If your screen is not responding to taps, use the 5-way navigator to open Touchscreen Preferences.

**1**

Open Touchscreen Preferences:

- a. **Go to Applications.**
- b. Select Prefs .
- c. Select Touchscreen.

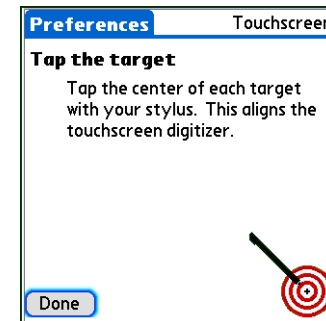
**2**

Tap the targets on the screen as precisely as possible, and then select Done.

**NOTE** You need to tap at least three targets—maybe more if you don't tap carefully.

↓ Done

## Selecting sound settings

Are sounds too soft or too loud? Set the volume levels for the system, game, and alarm tones, or turn sounds off altogether with the Silent profile.

\* **Tip**  
You can choose different types of sounds for Calendar, Tasks, and World Clock. Go to the application, open the Options menu, and then select Preferences.

+ **Did You Know?**  
When you connect headphones to your handheld, the external speaker is automatically silenced, the Sounds & Alerts settings are maintained, and all volume levels are automatically adjusted for use with headphones.

1

Open Sounds & Alerts Preferences:

- a. **Go to Applications.**
- b. Select Prefs .
- c. Select Sounds & Alerts.

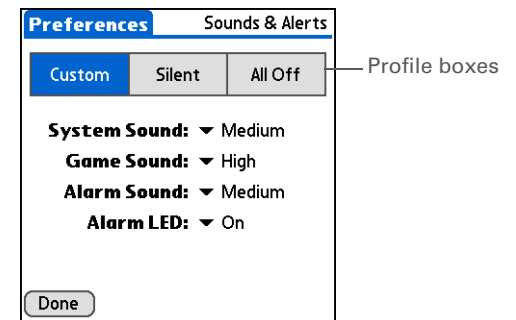

2

Select Custom, Silent, or All Off.

3

If you selected Silent or All Off in step 2, select Done.

If you selected Custom in step 2, tap the System Sound, Game Sound, and Alarm Sound pick lists and select the volume level for each sound; then select Done.

↓ Done

## Changing entries in Favorites



### + Did You Know?

You can quickly change multiple favorites on a page by selecting Menu on the status bar, and then selecting Edit Favorites Pages. Select the page you want, then select each favorite you want to change to open the Edit Favorites dialog box.

Change the entries in the Favorites View to include the applications, files, folders, or web links you use most often.

# 1

Open the Edit Favorites dialog box:

- a. Press Home  to open Favorites.
- b. Select the favorite you want to change.
- c. Select Menu  on the status bar.
- d. Select Edit Favorites.

# 2

Change the favorite:

- a. Select the favorite type from the Type pick list: application, file/folder, or web link.

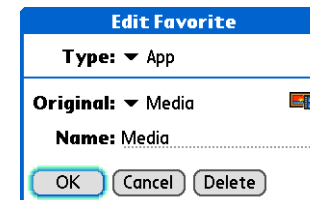

- b. Select the application from the Original pick list, tap to browse to the file or folder, or tap to enter the web address you want.
- c. Enter a name for your new favorite.
- d. Select OK.

 Done



### User Guide

For everything you need to know about your handheld—all that's in this guide, and much more—go to [www.palmOne.com/tungstent5-userguide](http://www.palmOne.com/tungstent5-userguide).

### My Handheld

Make your handheld uniquely yours. For great tips, software, accessories, and more, visit [www.palmOne.com/mytungstent5](http://www.palmOne.com/mytungstent5).

### Support

If you're having problems with customization or with anything else on your handheld, go to [www.palmOne.com/support/tungstent5](http://www.palmOne.com/support/tungstent5).

## Beyond the basics

Click the link to the left to go to the *User Guide* on the web and learn about these related topics:

### Customizing

- Setting power-saving features such as the auto-off interval
- Choosing formats for times, dates, calendar, and numbers based on a geographical region
- Selecting options for entering text, such as choosing how to enter certain Graffiti® 2 characters and using the full screen as the writing area
- Reassigning the buttons on the front of your handheld so that they open the applications you choose
- Protecting your information by turning on security options and entering information that identifies you as the owner of your handheld
- Configuring communication connections and network settings

# Common Questions

Although we can't anticipate all the questions you might have, this chapter provides answers to some of the most commonly asked questions.

## How do I upgrade from another Palm Powered™ device?

1. Synchronize your old handheld with your old desktop software.
2. Install the new Palm® Desktop software. There's no need to delete the old desktop software first.
3. Select the username you assigned to your old handheld during the desktop installation. This will transfer all your information from the old software to the new software.
4. Synchronize your new handheld with your new desktop software.
5. If any third-party applications do not transfer to your new handheld, reinstall them.
6. If you have problems with your third-party applications on your new handheld, you'll have to update them. If any of the following symptoms occur on your new handheld after you synchronize, remove the third-party applications and contact the vendor for updated versions:
  - Handheld freezes or resets when you open an application
  - Slow performance
  - Unusual screen display
  - Difficulties using handheld features
  - Uneven sound quality

### Why can't I find an icon in Applications View?

- Tap the category pick list in the upper-right corner of the Applications View screen and select All. You may need to scroll down a bit, but you should now see an icon for each of the applications on your handheld.
- Some of the applications that come with your handheld are not preinstalled. You need to **install these extra applications from your Tungsten™ T5 software installation CD.**

### How do I save my info?

Each time you complete an entry such as a contact, memo, or note, your handheld automatically saves the information you entered. You don't have to do anything special to save your info. To protect your info and create a backup of your info, we recommend that you synchronize your handheld with your computer often.

### How do I know when I need to recharge my handheld?

A battery icon  appears at the top of the Favorites and Applications screens. Check the gauge periodically to see if your handheld needs to be recharged. If the battery becomes low, a message appears on the screen prompting you to recharge the battery.

### Will I lose all my information if the battery becomes drained?

The memory on your handheld is designed to store your information even if the battery becomes drained to the point that you cannot turn on your handheld. When you recharge your handheld, all of your existing information, both in program memory and on the internal drive, should appear.

## How often should I recharge my handheld?

We recommend that you recharge your handheld for at least half an hour every day. Ideally, connect your handheld to a power source every night and recharge it while you sleep. Also, you can conserve battery life by doing any of the following:

- Reduce the **brightness** of the display.
- Reduce the **Auto-off after** setting.
- Use Keyguard Preferences to **prevent your handheld from being turned on accidentally**.
- Minimize use of the expansion card slot.
- **Turn the Bluetooth® feature off** when you're not using it.

## What do I do if I can't synchronize with my computer?

Make sure the USB sync cable is connected securely.

\* **Tip**  
Need more help with synchronizing your handheld? Open Palm Desktop software, go to the Help menu, and then select HotSync Online Troubleshooting Guide.

### WINDOWS ONLY

- Click the HotSync Manager  icon in the Windows taskbar in the lower-right corner of your screen. Make sure Local USB has a checkmark next to it. If not, click it.



- If you don't see the HotSync Manager icon, click Start on the Windows taskbar, and then select Programs. Go to the Palm Desktop program group and select HotSync Manager. Click the HotSync Manager icon when it appears in the system tray. Make sure Local USB is selected.

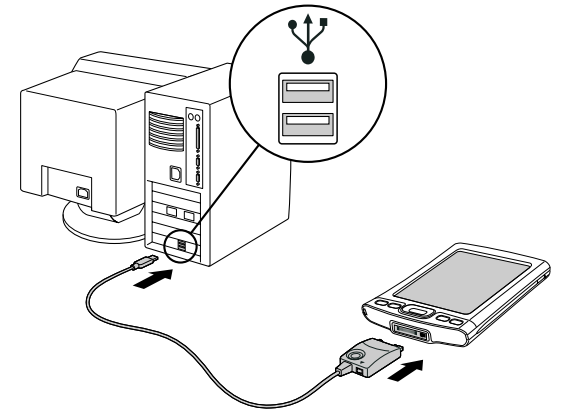

**MAC ONLY**

- Make sure HotSync Manager is enabled: Open the Palm folder and double-click the HotSync Manager icon. On the HotSync Controls tab, be sure Enabled is selected. If it is not, click it. On the Connection Settings tab, make sure USB has a checkmark next to it.
- Disconnect the USB sync cable from your computer, and then reconnect the cable and restart your computer.

**What do I do if I can't move or copy files using palmOne™ File Transfer?****WINDOWS ONLY**

- Make sure your handheld is connected securely to the USB sync cable, and that the cable is connected to a USB port on the rear of your computer.
- Make sure no other applications—such as synchronization or RealPlayer from palmOne—are using the USB sync cable.
- Try to synchronize. If synchronizing doesn't work, palmOne™ File Transfer doesn't work, either.
- If File Transfer was working but stops, disconnect and reconnect your handheld. If this does not solve the problem, **perform a soft reset**.

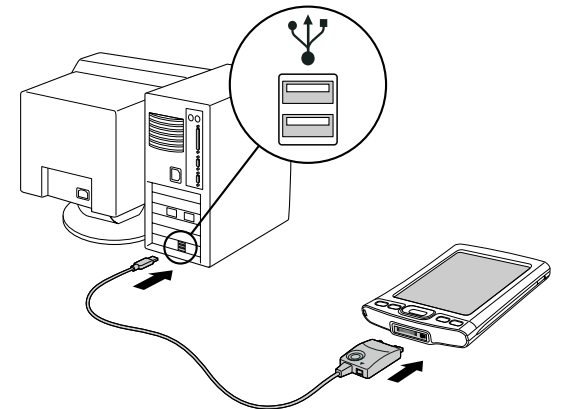
**What do I do if my handheld doesn't respond to taps correctly?**

If your handheld is not responding to taps correctly, you need to **align the screen**.

\* **Tip**  
After a soft reset, the Preferences screen appears with the Date & Time option highlighted so you can reset the date and time if necessary.

## What do I do if my handheld is not responding?

On rare occasions your handheld may not respond to tapping or pressing of buttons. If this happens, first check that **Keyguard** is not turned on.

If Keyguard is off and your handheld is still not responding, you need to reset your handheld. A soft reset tells your handheld to stop and start over again. This does not affect any of the information or applications on your handheld.

Unscrew the black reset tool from the top of the stylus and use the tip of the tool to gently press the reset button inside the hole on the back panel of your handheld.

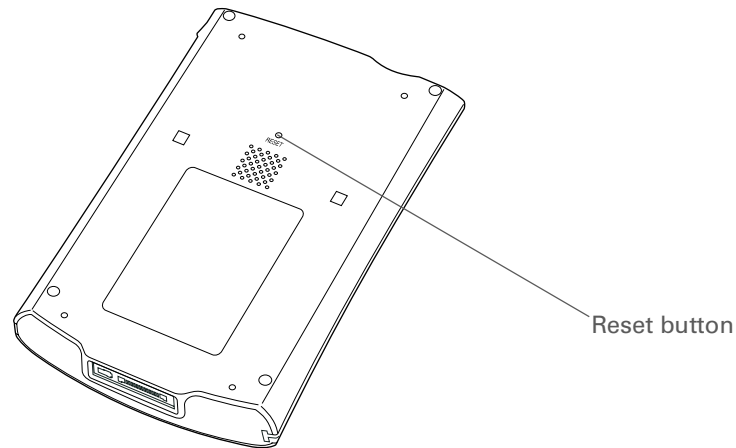

If a soft reset does not unfreeze your handheld, you need to **perform a hard reset**. For instructions see the *User Guide* on the web.

## Can I open my handheld?

No, do not open your handheld; there are no serviceable parts inside. Opening your handheld voids the warranty and is not recommended under any circumstances.

### **Why can't I see a file I moved from my computer to my handheld?**

Your handheld stores information in two locations: **program memory** and the **internal flash drive**. When you view files on your handheld using File Transfer on your computer or Files on your handheld, only files on the internal drive are displayed.

If you used palmOne™ Quick Install to move a file to your handheld, depending on the file type, the file may be located in your handheld's program memory. If this is the case, you can't view the file using File Transfer or Files, but you can access it by using the appropriate application. If you want to be able to see the file in the File Transfer window or the Files screen, copy it to your handheld's internal drive using File Transfer.

### **I made updates to a file on my handheld, but when I synchronize, why don't the changes show up in the file on my computer?**

If you use File Transfer to send a file to your handheld, any updates you make to the file on your handheld are not included when you synchronize. Use File Transfer to copy the updated file back to your computer.

### **Can I write a memo or enter a contact when my handheld is in Drive Mode?**

When your handheld is in Drive Mode, it works just like any external drive such as a CD drive. You cannot enter or work with information directly on your handheld while it is in Drive Mode. To work with information directly on your handheld, turn Drive Mode off.

When your handheld is in Drive Mode and is connected to a computer, you can open files from your handheld's internal drive on the computer using Windows Explorer or My Computer (on a Windows computer) or Finder (on a Mac computer), and work with them there.

Your handheld still displays alerts, such as for appointments or new email messages, when in Drive Mode.

## Beyond the basics

Click the link to the left to go to the *User Guide* on the web and learn about these related topics:

### Common Questions

- Troubleshooting software installation problems
- Solving problems with specific applications
- Troubleshooting synchronization problems
- Solving problems with beaming and communication settings

### Maintaining

Performing a hard reset if a soft reset does not unfreeze your handheld

### User Guide

For everything you need to know about your handheld—all that's in this guide, and much more—go to [www.palmOne.com/tungstent5-userguide](http://www.palmOne.com/tungstent5-userguide).

### My Handheld

Make your handheld uniquely yours. For great tips, software, accessories, and more, visit [www.palmOne.com/mytungstent5](http://www.palmOne.com/mytungstent5).

### Support

If you're having problems with your handheld, go to [www.palmOne.com/support/tungstent5](http://www.palmOne.com/support/tungstent5).



# Product Regulatory Information

## FCC Statement

This device complies with part 15 of the FCC rules. Operation is subject to the following two conditions: (1) This device may not cause harmful interference, and (2) this device must accept any interference received, including interference that may cause undesired operation.

This equipment has been tested and found to comply with the limits for a Class B digital device, pursuant to Part 15 of the FCC rules. These limits are designed to provide reasonable protection against harmful interference in a residential installation. This equipment generates, uses, and can radiate radio frequency energy and, if not installed and used in accordance with the instructions, may cause harmful interference to radio communications. However, there is no guarantee that interference will not occur in a particular installation. If this equipment does cause harmful interference to radio or television reception, which can be determined by turning the equipment off and on, the user is encouraged to try to correct the interference by one or more of the following measures:

- Reorient or relocate the receiving antenna.
- Increase the separation between the equipment and receiver.
- Connect the equipment into an outlet on a circuit different from that to which the receiver is connected.
- Consult the dealer or an experienced radio/TV technician for help.

The use of shielded I/O cables is required when connecting this equipment to any and all optional peripheral or host devices. Failure to do so may violate FCC rules.

**[ ! ] IMPORTANT** Changes or modifications not covered in this manual must be approved in writing by the manufacturer's Regulatory Engineering Department. Changes or modifications made without written approval may void the user's authority to operate this equipment.

In August 1996, the FCC of the United States with its action in Report and Order FCC 96-326 adopted an updated safety standard for human exposure to radio frequency electromagnetic energy emitted by FCC regulated transmitters. Those guidelines are consistent with the safety standard previously set by both U.S. and international standards bodies. The design of this product complies with the FCC guidelines and these international standards.

## Exposure to radio frequency energy (SAR)

In order to comply with FCC RF exposure safety guidelines, this device and its antenna must not be co-located or operating in conjunction with any other antenna or transmitter. The user of this device should ensure that the operation of this device is in compliance with these provisions.

### Responsible Party:

palmOne, Inc.  
400 N. McCarthy Blvd.  
Milpitas, California 95035  
United States of America  
(408) 503-7500



## Industry Canada

The term "IC:" before the certification/registration number only signifies that the Industry Canada technical specifications were met.

## Canadian Wireless Regulatory Notice

This Class B digital apparatus meets all the requirements of the Canadian Interference Causing Equipment Regulations. Operation is subject to the following two conditions: a) this device may not cause any interference, and b) this device must accept any interference, including interference that may cause undesired operation of the device. To prevent radio interference to the licensed service, this device is intended to be operated indoors, and away from windows to prevent maximum shielding. Equipment (or its transmit antenna) that is installed outdoors is subject to licensing.



## CE Declaration of Conformity

<b>palmOne, Inc., Declares the Product:</b>	Handheld PDA & HotSync® cable
<b>Model Name/Number:</b>	Tungsten T5
<b>Manufacturer's Name:</b>	palmOne

**Manufacturer's Address:** 400 N. McCarthy Blvd.  
Milpitas, 95035-5112

Meets the following European Council Directives:

- 89/336/EEC (EMC Directive)
- 99/5/EC (R&TTE Directive)
- 73/23/EEC (Low Voltage Directive).

Conforms with the following specifications:

- EN 55024: 1998 (Emissions & Immunity)
- EN55022:1998, CISPR 22 1997, Class B Radiated and Conducted Emissions
- IEC 61000-4-2, A1 1998-01, ESD Immunity, 4kV Contact, and 8kV Air Discharge
- IEC 61000-4-3: 1995 RF Immunity, 80-1000MHz, 3V/M, 1kHz, 80% A.M.
- ENV 50204:1996, RF Immunity, 895-905MHz, 3V/m, 200Hz, 50% AM
- IEC 61000-4-4: 1995 EFT Immunity, 1kV on AC port, 5/50nSec, 5kHs Rep. Freq.
- IEC 61000-4-5: 1995 Surge Immunity, 1.2/50uSec, 2kV(peak), Common Mode, 1kV(peak) Differential Mode
- EN61000-4-6:1996, Conducted Immunity, 150kHz-80MHz, 3V RMS, 1kHz, 80% AM
- IEC 61000-4-11: 1994, 100% Voltage Dip 0.5 period, 30% Dip 25 periods and >100% Dip 250 periods

**Authorized palmOne Representative:** David Woo  
Manager, palmOne, Inc., World Wide Compliance

**Date:** November 4, 2003

## Battery Warning

Do not mutilate, puncture, or dispose of batteries in fire. The batteries can burst or explode, releasing hazardous chemicals. Discard used batteries according to the manufacturer's instructions and in accordance with your local regulations.

### Varning

Eksplotionsfara vid felaktigt batteribyte. Använd samma batterityp eller en ekvivalent typ som rekommenderas av apparattillverkaren. Kassera använt batteri enligt fabrikantens instruktion.

### **Advarsel!**

Lithiumbatteri—Eksplodingsfare ved fejlagtig håndtering. Udskiftning må kun ske med batteri af samme fabrikat og type. Levér det brugte batteri tilbage tilleverandøren.

### **Varoitus**

Paristo voi räjähtää, jos se on virheellisesti asennettu. Vaihda paristo ainoastaan valmistajan suosittelemaan tyyppiin. Hävitä käytetty paristo valmistajan ohjeiden mukaisesti.

### **Advarsel**

Eksplodingsfare ved feilaktig skifte av batteri. Benytt samme batteritype eller en tilsvarende type anbefalt av apparatfabrikanten. Brukte batterier kasseres i henhold til fabrikantens instruksjoner.

### **Waarschuwing!**

Bij dit produkt zijn batterijen geleverd. Wanneer deze leeg zijn, moet u ze niet weggooien maar inleveren als KCA.

### **Uwaga**

Nie kroić lub przekłuwać baterii, ani nie wrzucać ich do ognia. Mogą się rozerwać lub wybuchnąć wydzielając trujące środki chemiczne. Zużytych baterii należy pozbywać się w sposób opisany przez producenta i zgodnie z miejscowymi przepisami.

אזהרה

יש סכנת התפוצצות אם מחליפים את הסוללה בצורה לא נכונה.  
יש להחליף את הסוללה בסוללה זהה או דומה, בהתאם להמלצת היצרן.  
יש להשליך סוללות משומשות בהתאם להוראות היצרן

## **Intrinsic Safety Warning**

### **Warning – Explosion Hazard**

- Substitution of components may impair suitability for Class I, Division 2;
- When in hazardous location, turn off power before replacing or wiring modules, and,
- Do not disconnect equipment unless power has been switched off or the area is known to be non-hazardous.

## **Wireless Notices— Usage Cautions**

In some situations, the user of the wireless device may be restricted. Such restrictions may apply aboard an airplane, in hospitals, near explosive environment, in hazardous locations etc. If you are not certain of the policy that applies to the use of this device, please ask for authorization prior to turning on the device.

## Static Electricity, ESD, and Your palmOne™ Handheld

Electrostatic discharge (ESD) can cause damage to electronic devices if discharged into the device, so you should take steps to avoid such an occurrence.

### Description of ESD

Static electricity is an electrical charge caused by the buildup of excess electrons on the surface of a material. To most people, static electricity and ESD are nothing more than annoyances. For example, after walking over a carpet while scuffing your feet, building up electrons on your body, you may get a shock -- the discharge event -- when you touch a metal doorknob. This little shock discharges the built-up static electricity.

### ESD-susceptible equipment

Even a small amount of ESD can harm circuitry, so when working with electronic devices, take measures to help protect your electronic devices, including your palmOne™ handheld, from ESD harm. While palmOne has built protections against ESD into its products, ESD unfortunately exists and, unless neutralized, could build up to levels that could harm your equipment. Any electronic device that contains an external entry point for plugging in anything from cables to docking stations is susceptible to entry of ESD. Devices that you carry with you, such as your handheld, build up ESD in a unique way because the static electricity that may have built up on your body is automatically passed to the device. Then, when the device is connected to another device such as a docking station, a discharge event can occur.

### Precautions against ESD

Make sure to discharge any built-up static electricity from yourself and your electronic devices *before* touching an electronic device or connecting one device to another. The recommendation from palmOne is that you take this precaution before connecting your handheld to your computer, placing the handheld in a cradle, or connecting it to any other device. You can do this in many ways, including the following:

- Ground yourself when you're holding your mobile device by simultaneously touching a metal surface that is at earth ground.
- For example, if your computer has a metal case and is plugged into a standard three-prong grounded outlet, touching the case should discharge the ESD on your body.
- Increase the relative humidity of your environment.
- Install ESD-specific prevention items, such as grounding mats.

### **Conditions that enhance ESD occurrences**

Conditions that can contribute to the buildup of static electricity in the environment include the following:

- Low relative humidity.
- Material type (The type of material gathering the charge. For example, synthetics are more prone to static buildup than natural fibers like cotton.)
- The rapidity with which you touch, connect or disconnect electronic devices.

While you should always take appropriate precautions to discharge static electricity, if you are in an environment where you notice ESD events, you may want to take extra precautions to protect your electronic equipment against ESD.

**SYMBOLS**

- \* (asterisk) characters 45
- ; (semicolon) characters 109

**NUMERICS**

- 5-way navigator 2, 12
  - scrolling application categories 23

**A**

- AC charger 4, 19
- accessing
  - additional software 9
  - applications 138
  - documentation on the web ix
  - email accounts 5, 95, 97, 101
  - files 27
  - information 12
  - internal flash drive 27
  - program memory 27
  - web pages 119, 120
  - websites 92, 97, 118
- accessories 4, 20, 25, 43, 49, 55, 59, 68, 77, 82, 86, 90, 103, 113, 117, 120, 122, 125, 136, 143
- Account Setup screen 105
- accounts (email)
  - creating 105
- Accounts command 108
- adding
  - additional software 122
  - contacts 45, 47
  - email messages 109
  - events 51
  - expansion cards 122
  - files to handheld 26–43
  - memos 83, 84, 85
  - notes 88
  - reminders 46, 87
  - tasks 78, 79
- Addit software 6
- additional references and resources ix
- Additional Software option 7
- add-on applications 137
- addresses 3
  - See also* contacts
- addressing
  - email 49, 109
  - text messages 115
- adjusting speaker volume 134
- Adobe Acrobat Reader vii, 9
- agenda lists 50
  - See also* Calendar application
- Agenda View (Calendar) 53
- alarm clock 54
- Alarm Sound pick list 134
- alarms
  - See also* reminders
  - adjusting volume for 134
  - attaching to notes 88
  - customizing 55
  - icon on status bar 10
  - incoming messages and 117
  - selecting sounds for 54, 82
  - setting 54, 79, 82, 90
- albums
  - additional information for 68
  - creating 64
  - moving photos in 65
  - selecting 65

- alerts
  - icon on status bar 10
- alerts *See* alarms
- aligning screen 133
- anniversaries 52
- application icons 138
- applications
  - See also* specific built-in application
  - accessing 138
  - adding contact information to 47
  - additional information for 20, 125
  - copying 125
  - deleting 20, 125
  - exchanging 20, 125
  - installing 7, 29
  - not finding 5
  - opening 12, 136
  - selecting 12
  - setting local preferences for 127
  - soft resets and 141
  - storing on expansion cards 125
  - transferring information from 31
  - transferring third-party 137
  - transferring to handheld 7, 8, 29
  - troubleshooting 138, 143
- Applications View
  - adding background to 132
  - icon on status bar 10
  - moving around 13
  - opening applications in 23
  - using 23
  - using the 5-way 13
- Applications view
  - displaying icons on 138

appointments  
*See also* Calendar application; events  
adding notes to 55  
color-coding 52, 55  
combining tasks with 50  
creating recurring 55  
deleting 55  
filing 52  
repeating 54  
scheduling 51–52  
setting duration of 52  
sharing 3

ASF media files 61

asterisk (\*) characters 45

attachments

- adding 112
- downloading 110
- sending events as 49, 55
- sending files as 112
- sending memos as 86
- sending multimedia files as 68
- sending notes as 90
- sending tasks as 82

Attachments screen 112

Audible Player software 8

audio applications 3, 69

audio files 70–71

auto-off interval 136, 139

## **B**

back panel controls 4

backgrounds

- changing 88
- customizing 132

backing up information 7, 122

internal flash drive 37

battery

- cautions for 146
- charging 19, 138
- conserving power for 129
- extending life of 126, 139

battery icon 138

Beam Category command 79

Beam Contact command 48

Beam Item command 79

Beam Status dialog box 48

beaming 3, 20, 48, 143

birthdays 46

Blazer application *See* web browser

blinking cursor 16

Bluetooth Access Points 103

Bluetooth application

- additional information for 103
- computer setup options for 99
- features 92
- icon on status bar 10
- opening 93, 94, 99
- setting connection information 93
- setting up connections 94–96
- status bar icon 97

Bluetooth devices

- built-in software for 6
- connecting to 4, 92
- sending applications to 20, 125
- sending entries to 20, 125
- sending events to 55
- sending memos to 86
- sending notes to 90
- sending task entries to 82
- setting up 93

- synchronizing with 43

- turning off 139

- verifying status of 97

Bluetooth icon 5

Bluetooth LAN Access Points 92

Bluetooth™ technology 91, 92

BMP files 61

bold fonts 131

bookmarks 120

browsing the web 5, 97, 118

built-in applications 5

Business Card command 48

business cards 48

buttons

- locking 129
- navigator 12
- quick 2
- reassigning application 136

## **C**

Calculator application 6

Calculator icon 6

calculators 6

calendar

- color-coding appointments 52, 55
- formatting 136
- selecting dates on 79

Calendar application

- additional information for 55
- benefits of 50
- checking schedules in 53
- customizing 132
- entering birthdays for 46
- opening 5, 51



- scheduling appointments in 51–52
  - setting alarms 54
- Calendar icon 5
- calendar views 53
- calibration 133
- capitalization 84
- Card Info application 6, 125
- Card Info icon 6
- carrying cases 122
- categorizing
  - contacts 49
  - events 55
  - information 20, 52
  - memos 86
  - notes in Note Pad 90
  - tasks 80
- CDs 72
- changing
  - backgrounds 88
  - email accounts 113
  - fonts 130–131
  - memos 85
- character entry 15, 45, 119, 136
- charging battery 19, 138
- chat rooms ix
- check boxes
  - using the 5-way 14
- checking for email 108
- Choose Date command 79
- choosing information 2
- cleaning your handheld 19
- clock 127–128
  - See also* World Clock
- Color Theme Preferences screen 135

- color-coding
  - appointments 52, 55
  - messages 113
- colors, applying to notes 88
- commands 18
- communication settings 143
- compact discs 72
- completed tasks 81
- computers
  - connecting to 92
  - Drive Mode and 40–42
  - File Transfer and 36–39
  - installing software on vii
  - preinstalled software for 7
  - synchronizing handheld with 99
  - synchronizing with 31
  - troubleshooting File Transfer problems 140
  - troubleshooting synchronization problems 139
- configuring
  - connections 136
- confirmation tones 124
- conformity declaration 145
- connecting
  - headphones to handheld 3
  - to AC charger 4
  - to Bluetooth devices 4, 92, 93
  - to mobile phones 98
  - to other devices 91
  - to personal computers 92
  - to the Internet 92
- Connection Setup screen 94
- connection types 92

- connections
  - additional information for 103
  - configuring 136
  - customizing 117, 120
  - omitting passkeys for 95
  - precautions for 19, 148
  - setting preferences for 113
  - setting up phone 94–96
  - setting up wireless 91, 99
  - troubleshooting 143
  - unable to establish 93
- conserving power 129
- contacting ISPs 96
- contacts
  - See also* Contacts application
  - adding 45, 47
  - beaming 48
  - categorizing 49
  - copying information for 46
  - deleting 49
  - entering in memos 84
  - keeping private 49
  - locating 47
  - managing 44
  - saving 46
- Contacts application
  - adding contact information 45–46
  - additional information for 49
  - benefits of 44
  - customizing 49
  - opening 5, 45
  - saving information in 46
  - searching from 47
- Contacts icon 5
- continuous events *See* repeating events

- controls, handheld 2
- copying
  - applications 125
  - contacts 46
  - photos 68
  - videos 68
- corporate email accounts 113
- CPUs
  - connecting to 92
  - Drive Mode and 40–42
  - File Transfer and 36–39
  - installing software on vii
  - preinstalled software for 7
  - synchronizing handheld with 99
  - synchronizing with 31
  - troubleshooting File Transfer problems 140
  - troubleshooting synchronization problems 139
- creating
  - appointments 51
  - contacts 45, 47, 48
  - email messages 109
  - memos 83, 84, 85
  - MP3 files 72
  - notes 88
  - photo albums 64
  - recurring events 54, 55
  - reminders 46, 87
  - song lists 73, 77
  - tasks 78, 79
- current date and time 127
- cursor 16
- customer support ix, 20, 25, 59, 77, 103, 113, 117, 120

- customizing
  - alarms 55
  - backgrounds 132
  - connections 117, 120
  - Contact application 49
  - handheld 6, 126, 136
  - Inbox 113
- cutting and pasting 86

## D

- data entry 16, 20, 136
  - caution for 3
  - input area for 2
- Date & Time Preferences screen 127
- dates
  - See also* calendar
  - assigning to appointments 51
  - defining start and end times for 55
  - formatting 136
  - scheduling reminders for 46
  - selecting on calendar 79
  - setting 127–128
  - setting due 79
  - sorting by 89
- Day View (Calendar) 51, 53
- Day View icon 51
- Deactivate Keypad button 129
- defaults 55
- deleting
  - See also* removing
  - applications 20, 125
  - appointments 55
  - contacts 49
  - email accounts 113
  - files 125

- memos 86
- messages 117
- photos 49, 65, 68
- songs 77
- videos 68
- description fields 51
- desktop software, installing 7
- Device name field 93
- devices 3
- dialing phone numbers 95
- dialog boxes
  - using the 5-way 14
- dial-up accounts 96, 98
- dictionaries 122
- Digitizer Preferences screen 133
- digitizer *See* touchscreen
- Discoverable setting 93
- display brightness 139
- display options 55, 113, 132
  - See also* preferences
- Display Options command 132
- displaying
  - application icons 138
  - calculators 6
  - expansion card information 6
  - expense reports 6
  - images 61
  - information 2
  - items in lists 13, 14
  - memos 85
  - notes 89
  - PDF files 9
  - personal calendars 50
  - photos 61, 68
  - schedules 53

- song lists 75
- tasks 80, 82
- videos 68
- web pages 119
- World Clock 6
- do's and don'ts 19
- documentation vii, 8, 20, 25, 43, 49, 55, 59, 68, 77, 82, 86, 90, 103, 113, 117, 120, 125, 136, 143
- Documents application 5
  - creating files 57
  - editing files 57
  - opening files 58
  - viewing files 57
- Documents To Go desktop application 57
- download options 111
- downloading
  - attachments 110
  - email 108
  - files 120
- drawing freehand 87
- Drive Mode
  - defined 6
  - transferring MP3 files 71
  - using 40
  - working on handheld 142
- drivers 103
- due dates 79
- dummy expansion card 123

## E

- eBooks 9
- Edit Categories command 80
- editing 85, 88, 89, 113
  - See also* changing

- electrostatic discharge 148–149
- email
  - See also* email accounts
  - accessing 5, 95, 97, 101
  - adding attachments to 112
  - additional information for 113
  - addressing 49, 109
  - attaching events to 49, 55
  - attaching memos to 86
  - attaching notes to 90
  - attaching photos to 68
  - attaching tasks to 82
  - automatically checking for 108
  - automatically retrieving 113
  - changing maximum size 108
  - composing 109
  - deleting accounts for 113
  - downloading 108
  - downloading attachments 110
  - receiving 97, 103, 106, 108
  - sending 97, 103, 106, 109
  - setting preferences for 113
  - synchronizing 106, 108, 113
- email accounts
  - creating 105
- email applications 104
- email providers 106
  - See also* ISPs
- enhancing photos and videos 68
- entering
  - information 2, 15–17, 20, 31–33, 136
  - passwords 96, 106
  - URLs 119
- entries
  - defined 16

- moving around 14
  - sorting 49, 86, 90
- entry screens 14
- eraser 88
- eReader 9
- errors viii
- ESD (electrostatic discharge) 148–149
- Essential Software option 7
- Euro, in onscreen keyboard 17
- Event Details dialog box 54
- events
  - See also* appointments
  - adding notes for 55
  - categorizing 55
  - contact information and 46
  - creating recurring 54, 55
  - defined 51
  - entering 52
  - setting alarms for 54
  - sharing 55
- Excel files 5, 104
  - creating and viewing 57
  - transferring to handheld 30
- exchanging
  - applications 20, 125
  - event entries 55
  - expansion cards 125
  - files 92, 104
  - information 3, 20, 31
  - memos 86
  - notes from Note Pad 90
  - task entries 82
- expansion card slot 3, 139
- expansion cards
  - adding applications to 7, 8, 125

- additional information for 125
- benefits of 122
- deleting applications from 125
- deleting songs on 77
- displaying contents of 125
- displaying information about 6
- dummy card 123
- inserting 3, 124
- naming 125
- overview 121
- preventing damage to 123
- removing 123
- saving multimedia files on 61, 68
- transferring audio files to 70–75
- types of 122

Expense application 6

Expense icon 6

expense reports 6

external devices 3

## **F**

fade setting 132

FAQs 137

Favorites View

- changing entries 135
- defined 5
- icon on status bar 10
- moving around 12
- using 22
- using the 5-way 12

Favorites view

- adding background to 132

FCC Statement 144

file linking 43

File Transfer application

- backing up internal drive 37
- defined 8
- overview 28
- troubleshooting 140
- using 36
- viewing internal flash drive 142

file transfers 120

file types 61, 70

files

- attaching to email 112
- deleting 125
- removing from expansion cards 125
- sharing 92
- transferring to handheld 8, 104

Files application

- defined 5
- opening 24
- using 24
- viewing internal flash drive 142

filing appointments 52

Find icon on status bar 10

finding contacts 47

flash drive on handheld 27

font styles 130, 131

fonts

- changing 130–131
- customizing email 113

formats

- multimedia file types 61
- setting 136

formatting information 136

freehand drawing 87

frequently asked questions 137

front panel controls 2

frozen screen 141, 143

full-screen writing 88

- icon on status bar 10

## **G**

Game Sound pick list 134

games 122, 134

General Packet Radio Service (GPRS) 96

Get Mail Options dialog box 108

getting started vii, viii, 8

Getting Started Guide 8

Go To Date dialog box 51

going online 92

GPRS carriers 103

GPRS mobile phones 94, 96

Graffiti 2 writing 15, 20, 136

GSM carriers 103

GSM mobile phones 94

## **H**

handheld

- adding additional software 122
- adding applications to 20, 137
- additional information for 20, 25, 43, 49, 55, 59, 68, 77, 82, 86, 90, 103, 113, 117, 120, 125, 136, 143
- connecting to AC charger 4
- controls described 2
- copying applications on 125
- customizing 6, 126, 136
- do's and don'ts 19
- ESD and 148
- getting additional information about ix
- losing 129
- naming 93

- not responding 129, 141, 143
- opening 141
- preinstalled applications for 5
- protecting 95, 136
- recharging 19, 138
- removing applications from 20
- resetting 4
- restarting 141, 143
- running out of space on 122
- setting up *vii*
- synchronizing 43, 137, 138, 139
- synchronizing wirelessly 92
- troubleshooting 133, 137, 143
- turning on and off 129
- upgrading 137
- viewing applications on 2
- viewing information on 2
- hard resets 141, 143
- headphone jack 3
- headphones 3, 19, 134
- help *ix*, 20, 25, 43, 49, 55, 59, 68, 77, 82, 86, 90, 103, 113, 117, 120, 125, 136, 143
- Help menu 139
- high-speed connections 98
- high-speed wireless carrier 92
- holidays 52
- home page 120
- Home screen *See Applications View*
- HotSync icon 6
- HotSync Manager 99, 139
  - starting 6
- HotSync Online Troubleshooting Guide 139
- HotSync technology 34
- how-to information *viii*

## I

- icons 138
- image files 61
- IMAP protocol 105
- IMAP servers 106
- importing contact information 49
- Inbox 113
- incoming mail servers 106
- incoming messages 117
- information
  - accessing 12
  - backing up 7, 122
  - categorizing 20, 52
  - caution for entering 3
  - displaying 2
  - entering 2, 15–17, 20, 31–33, 136
  - formatting 136
  - in program memory 27
  - losing *viii*, 141
  - managing 7
  - owner 129
  - receiving from outside sources 43
  - saving 138
  - security options for 136
  - selecting 2
  - sharing 3, 20, 46, 83, 125
  - synchronizing 31
  - updating 31
- infrared port *See IR port*
- input area 2
  - icon on status bar 10
- inserting expansion cards 3, 124
- installation CD 7
- installing
  - additional software 7

- applications 7
  - Palm Desktop software 7
  - third-party applications 137
- internal flash drive 27
  - backing up 37
  - difference between program memory and 27
  - viewing contents 27, 142
- Internet 96, 118
  - See also websites*
  - accessing 92
  - browsing 92
  - connecting to 92
  - selecting service provider for 98
- Internet Message Access Protocol (IMAP) 105
- Internet Service Providers (ISPs) 92, 106
- IR port 48, 103
  - location of 3
- ISPs 92, 96, 106
- iTunes
  - transferring songs from CD 72

## J

- J2ME files 9
- jack (headphone) 3
- Java Technologies software 9
- JPG files 61

## K

- key terms *ix*
- keyboard
  - entering information from 16
  - onscreen types 17

keyboards  
    connecting to portable 85  
Keyguard 3, 129, 139  
Keyguard Preferences screen 129

## L

landscape view 11  
laptops 92  
Large bold icon 131  
Large font icon 131  
linking to outside sources 43  
links (documentation) viii  
list screens 13  
listening to music 3, 69, 70, 76  
lists  
    additional information for 68  
    displaying song 75  
    moving around items in 13  
local settings 127, 136  
locating contacts 47  
Location pick list 127  
locking handheld buttons 129  
Look Up line (Contacts) 47  
losing handheld 129  
losing information viii, 141  
Lotus Notes 106  
low battery 138

## M

Mac information  
    described viii  
    displaying videos 61  
    installing extra software from CD 7  
    phone connections 94  
    Send To Handheld droplet 36

    synchronizing handheld 140  
    transferring MP3 files to handheld 71  
magnifying glass (Adobe Reader) vii  
mail servers 106  
Mail Service pick list 106  
math calculators 6

## Media

    desktop application 30  
Media application  
    adding photo to contact 46  
    additional information for 68  
    annotating photos 67  
    backing up information in 7  
    benefits of 60  
    displaying multimedia files 64  
    displaying photos or videos 62  
    opening 62  
    overview 60

## Media icon 5

## memos

*See also* notes; Memos application  
    adding contact information to 47, 84  
    backing up 7  
    categorizing 86  
    creating 83, 84, 85  
    deleting 86  
    displaying 85  
    editing 85  
    exchanging 86  
    keeping private 86  
    saving 84  
    sending as attachments 86  
    synchronizing 86

## Memos application

    additional information for 86

    changing memos in 85  
    opening 6, 84  
    overview 83  
    selecting memos 85  
    writing memos with 84  
Memos icon 6  
Memos list 84, 85  
menu bar 18  
menus 18  
    icon on status bar 10  
message summary view 113  
messages  
    *See also* email; text messages  
    automatically resending 109, 113  
    color-coding 113  
    connection types for 92  
    deleting 117  
    receiving 92, 115, 117  
    replying to 117  
    synchronizing 106, 108, 113  
Messages option 108  
Microsoft Outlook 43  
    applications that synchronize 31  
    transferring into to handheld 29  
Microsoft Word files 5, 104  
missing applications 5  
mobile phones 94  
    accessing Internet with 92  
    connecting to 92, 98  
    connecting to Internet from 98  
Month View (Calendar) 53  
moving files into internal flash drive 36–42  
moving photos 65  
moving through documentation vii

MP3 files 70–71  
    transferring to handheld 30  
MP3 players 69  
Multi-connector 4  
multi-line descriptions 51  
multimedia file types 61  
MultiMediaCard expansion cards 122  
multiple email recipients 109  
music  
    creating song lists for 73  
    listening to 3, 69, 70  
    playing 69, 76  
    storing 122  
Music application 76, 77  
music files  
    *See also* MP3 files, song files  
    transferring to handheld 30

**N**  
names *See* usernames; contacts  
naming  
    email accounts 105  
    handheld 93  
    photo albums 64  
naming expansion cards 125  
navigating through documentation vii  
navigator 2, 12  
network connections  
    additional information for 103  
    setting preferences for 113, 117, 120  
    setting up 95, 136  
networks 43  
    accessing email from 92  
new lines 84

Note Pad  
    *See also* notes  
    additional information for 90  
    backing up information in 7  
    creating notes from 88  
    displaying notes in 89  
    opening 6, 88  
    overview 87  
    setting preferences for 88  
Note Pad icon 6  
notes  
    *See also* memos; Note Pad  
    adding to events 55  
    adding to tasks 82  
    backing up 7  
    creating 88  
    editing 88, 89  
    saving 88  
    selecting 89  
    sorting 89  
notes (Note Pad)  
    attaching alarms to 90  
    attaching to email 90  
    keeping private 90  
    organizing 90  
    setting alarms for 88  
    sharing 90  
numbers 15, 136

**O**  
Office files 30, 56–59  
omitting passkeys 95  
online documentation 20, 25, 43, 49, 55, 59,  
    68, 77, 82, 86, 90, 103, 113, 117, 120,  
    125, 136, 143

Online Troubleshooting Guide 139  
onscreen keyboard *See* keyboard  
Open URL dialog box 119  
Open URL icon 119  
opening  
    applications 12, 136  
    handheld 141  
    handheld menus 18  
    HotSync Manager 6, 99  
    Note Pad 6, 88  
    photo albums 65  
    RealPlayer 5  
    text messages 116  
optional information viii  
orientation of screen 11  
outgoing mail servers 106  
Outlook  
    marking completed tasks and 81  
    synchronizing with 106  
Outlook Express 106  
overdue tasks 80  
owner information 129, 136  
Owner Preferences screen 129

**P**  
paging through documentation vii  
Palm Desktop software 137  
    completing repeated tasks and 81  
    described 7  
    installing 7  
    transferring info to handheld 29  
Palm OS handhelds  
    beaming to 20, 55, 125  
    exchanging memos with 86

- sharing notes with 90
  - sharing tasks with 82
- paper clip icon 110, 111
- passkeys 95, 101
- Password check box 106
- passwords 95, 96, 101
  - entering 106
- pasting text 86
- PC Setup screen 99
- PCs *See* personal computers
- PDA's 1
- PDF files 9
- pen 88
- Pen selector 88
- pen widths 88
- performance 19
- personal computers
  - connecting to 92
  - installing software on vii
  - preinstalled software for 7
  - synchronizing with 31
  - troubleshooting File Transfer 140
  - troubleshooting synchronization 139
- personal digital assistants (PDA's) 1
- phone calls 49
- phone connections 94–96
- phone drivers 103
- Phone Link Updater application 94, 103
- Phone Lookup 47
- phone numbers 49, 95
  - getting from contacts 47
  - sharing 3
  - temporary storage for 87
- photo albums
  - additional information for 68
  - creating 64
  - moving photos in 65
  - selecting 65
- photos
  - adding to albums 65
  - adding to contacts 46
  - copying 68
  - deleting 49, 65
  - displaying 68
  - emailing 68
  - moving 65
  - saving 61
  - selecting as backgrounds 132
  - sharing 35, 66
  - storing 122
  - transferring to handheld 30
- pick lists
  - using the 5-way 14
- Picture box 46
- PIM applications, transferring info to handheld 29
- playing music 69, 70, 76
- playlists 73, 75, 77
  - See also* music
- POP protocol 105
- POP servers 106
- portable keyboards 85
- portrait view 11
- ports 3
- Post Office Protocol (POP) 105
  - See also* POP servers
- power button 3
- PowerPoint files
  - creating and viewing 57
  - transferring to handheld 30
- power-saving features 136
- precautions 148
- preferences
  - additional information for 136
  - overview 126
  - setting connection 113
  - setting email 113
  - setting locale-specific 127
  - setting network connection 117, 120
  - setting text messaging 117
- Preferences screen 6
- Prefs icon 6
- preinstalled applications 5
- prerequisites ix
- Previous View icon (Adobe Reader) vii
- printing
  - expense reports 6
  - online documentation vii
- prioritizing tasks 79
- privacy settings
  - calendar 55
  - contacts 49
  - handheld 20
  - memos 86
  - notes 90
  - tasks 82
- program memory 27
  - difference between internal flash drive and 27
  - synchronization and 28
  - viewing contents 142
- programs *See* software; applications
- protecting information 122
- protecting your handheld 19, 20, 136
- protocol (defined) 105



Protocol pick list 106  
purging old appointments 55

## Q

questions and answers 137  
quick buttons  
    location of 2  
    opening applications from 5  
Quick Connect option 49  
Quick Install software 7  
    using 35  
Quick Look Up icon 47  
Quick Look Up line 47  
Quick Tour 6, 15

## R

radio 4, 8  
Read This First vii  
reading  
    text messages 116  
Real Music Store 76  
RealPlayer  
    benefits of 69  
    compatible formats for 70  
    converting songs on CDs 72  
    getting help with 74, 76, 77  
    installing 8  
    opening 5  
    transferring MP3 files 70  
    transferring songs from CD 72  
RealPlayer icon 5  
reassigning quick buttons 136  
reboots 141, 143  
receiving email 97, 103, 106, 108  
receiving messages 92, 115, 117

recharging handheld 19, 138  
recurring events 54, 55  
recurring tasks 82  
refreshing web pages 120  
reminders  
    creating 87  
    entering 52  
    scheduling 46  
    setting alarms for 82, 88, 90  
removing  
    *See also* deleting  
    expansion cards 123  
    selection highlight 12  
repeating events 54, 55  
repeating tasks 81, 82  
replying to text messages 117  
required steps viii  
resending messages 109, 113  
reserving blocks of time 55  
reset button 4, 141  
resetting handheld 4  
resetting local settings 127  
resizing  
    text 85  
restarting handheld 141, 143  
rotating the screen 11  
    icon on status bar 10  
running out of space 122

## S

saving  
    attachments 110  
    contacts 46  
    information 138  
    memos 84

    notes 88  
    photos 61  
    tasks 79  
schedules 50, 53  
    *See also* appointments; calendar  
scheduling  
    appointments 51–52  
    backup and synchronization 31  
    reminders 46  
scheduling conflicts 50  
screen  
    adjusting brightness 139  
    aligning 133  
    caring for 19  
    caution for 3  
    changing colors of 135  
    changing fonts for 130, 131  
    frozen 141, 143  
    landscape and portrait views 11  
    moving through 2  
    viewing information on 2  
screen rotation 11  
    icon on status bar 10  
scrolling 12, 13, 14, 51  
SD memory cards 122  
SDIO accessories 122  
SDIO cards 122  
searching for information 47  
Secure Digital input/output (SDIO) 122  
security options  
    calendar 55  
    contacts 49  
    handheld 20, 95, 136  
    memos 86

- notes 90
- tasks 82
- Security settings 129
- Select a Color Theme dialog box 135
- Select Font dialog box 131
- Select User dialog box 34
- selecting information 2
- selection highlight 12, 13
- semicolon (;) characters 109
- Send To Handheld droplet 8
  - using 35
- sending
  - email 97, 103, 106, 109
  - text messages 92, 95, 114, 115
- service (defined) 98
- Service pick list 98
- services 98
- Set Date dialog box 128
- Set Time dialog box 52, 128
- setting alarms 54, 79, 82, 90
- setting up wireless connections 91
- settings 18
  - See also* preferences
- sharing
  - files 92
  - information 3, 46, 83
  - photos 35
- sharing information 20, 125
- Short Message Service (SMS) 115
- short messages 114
- shortcuts ix
- side panel controls 3
- sidebars (documentation) ix
- Silent profile 134
- sketching 87

- slide shows 62, 68
- Small bold icon 131
- Small font icon 131
- SMS application
  - additional information for 117
  - benefits of 114
  - installing 6
  - opening 115
  - sending text messages 115
- SMS messages 115
- SMS messaging 6
- SMTP servers 106
- soft resets 141
- software vii, 143
  - See also* specific application
  - accessing additional 9
  - adding additional 122
  - included on handheld 5
  - installing 7
- Solitaire 9
- song files *See* MP3 files; music files
- song lists 73, 75, 77
- songs 76, 77
  - See also* music
- Sort by pick list 89
- sorting
  - notes 89
- sorting information 49, 86, 90
- sound files
  - See also* audio files; music files
- sounds 134
  - See also* music; voice memos
- Sounds & Alerts screen 134
- speaker 4, 134
- special characters 15

- specifications 146
- spreadsheets 5, 104
  - creating and viewing 57
  - transferring to handheld 30
- starting HotSync Manager 6
- static electricity 19, 148–149
- status bar icon descriptions 10
- stereo headphones 3
- stopping MP3 player 76
- stopping slide shows 62
- storage 121, 122
- stylus 3, 19
- Subject fields 109
- subject lines (email) 109
- Subjects Only option 108
- supported file types 61, 70
- symbols 15, 45
- synchronization problems 143
- Synchronize Only Account check box 106, 108
- synchronizing
  - email 106
  - handheld 137, 138, 139
  - info not updating 142
  - information 31
  - messages 106, 108, 113
  - overview 28
  - wirelessly 43, 92, 99
  - with Microsoft Outlook 106
- system information, icon on status bar 10
- System Sound pick list 134

## T

- tapping 133, 140
- Task Preferences settings 82
- tasks
  - adding contact information to 47
  - adding notes to 82
  - assigning due dates to 79
  - attaching to email 82
  - categorizing 80
  - combining with appointments 50
  - completing 81
  - creating 79
  - defining recurring 82
  - displaying 80, 82
  - managing 78
  - organizing 80
  - prioritizing 79
  - saving 79
  - setting alarms for 79, 82
  - sharing 82
- Tasks application
  - adding tasks 79
  - additional information for 82
  - marking completed tasks 81
  - opening 6, 79
  - overview 78
  - saving information in 79
  - securing contents 82
  - setting display options for 80
- Tasks icon 6
- Tasks list 80
- technical assistance ix, 20, 25, 59, 77, 103, 113, 117, 120
- technical terms ix
- telephone numbers *See* phone numbers

## text

- adjusting fade setting for 132
- changing fonts for 130
- cutting and pasting 86
- entering 15, 136
- resizing 85
- text messages
  - additional information for 49
  - creating 49
  - deleting 117
  - managing 6
  - opening 116
  - sending 92, 95, 114, 115
  - setting preferences for 117
  - viewing 116
- third-party applications 137
- thumbnails 68
- TIFF files 61
- time
  - formatting 136
  - reserving blocks of 55
  - scheduling 52
  - setting 54, 127–128
  - setting location-specific 6
- tips ix
- To Do lists *See* tasks
- top panel controls 3
- touchscreen
  - aligning screen 133
  - defined 133
- tracking completion dates 82
- tracking expenses 6
- transferring
  - applications 7, 8
  - files 8, 104

## information 3, 31

- wirelessly 92
- travel guides 122
- troubleshooting 133, 137, 143
- trusted pairs 92, 95
- Tungsten handheld *See* handheld
- turning handheld on and off 129
- Tutorial 9

## U

- underlined words (in documentation) viii
- uniform resource locators (URLs) 119
- unread mail 113
- untimed events 46, 52
- updating information 31
- upgrading 137
- URLs 119
- USB connectors 4
- USB sync cable 4, 34
- User Guide 20, 25
- User's Guide vii, viii
- usernames 34, 96
  - finding in email addresses 106

## V

- VersaMail application 5
  - adding attachments 112
  - additional information for 113
  - benefits of 104
  - downloading attachments 110
  - getting email 108
  - opening 105
  - sending email 109
  - setting up email accounts 105–107

- videos
  - copying 68
  - deleting 68
  - displaying 68
  - sharing 66
  - transferring to handheld 30
- view formats 55
- viewing
  - application icons 138
  - calculators 6
  - expansion card information 6
  - expense reports 6
  - files on internal flash drive 27
  - images 61
  - information 2
  - items in lists 13, 14
  - memos 85
  - notes 89
  - PDF files 9
  - personal calendars 50
  - photos 61, 68
  - schedules 53
  - song lists 75
  - tasks 80, 82
  - videos 68
  - web pages 119
  - World Clock 6
- views in Calendar 53
- virtual private networks 9, 113
- volume 134
- VPN Link 9

## W

- warnings 146
- warranty 141
- web addresses 119
- web browser
  - additional information for 120
  - displaying web pages 119
  - overview 118
- web pages 119, 120
- websites
  - accessing 92, 97, 118
  - adding bookmarks for 120
  - as additional resources ix
  - browsing 5, 97
  - downloading files 120
  - navigating 119
- Week View (Calendar) 53
- Windows information
  - described viii
  - displaying videos 61
  - installing handheld software 7
- Windows Media Player 8
- wireless carriers 92
- wireless connections 91, 92, 99, 115
- wireless email accounts 106
- wireless features 97
- wireless synchronization 43, 92, 99
- Word files 5, 104
  - creating and viewing 57
  - transferring to handheld 30
- World Clock 54
- World Clock icon 6
- World Clock, displaying 6
- World Wide Web *See* web pages; websites
- writing area 136

- writing in your own handwriting 87
- writing tool 3, 19

## Y

- Year View 53