

Monarch®
PAXAR

Pathfinder™
Scout Peripheral Printer

Operator's Handbook

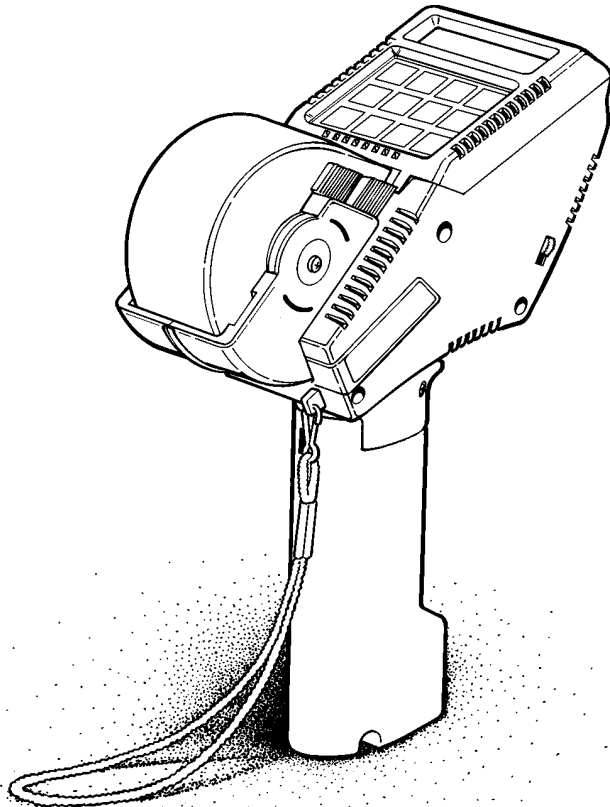

Each product and program carries a respective written warranty, the only warranty on which the customer can rely. Monarch reserves the right to make changes in the product and the programs and their availability at any time and without notice. Although Monarch has made every effort to provide complete and accurate information in this manual, Monarch shall not be liable for any omissions or inaccuracies. Any update will be incorporated in a later edition of this manual.



WARNING

This equipment can interfere with radio communication if not installed and used in accordance with the instruction manual. It has been tested and found to comply with the limits for a Class A computing device pursuant to FCC Rules, Part 15, Subpart B, which provide reasonable protection against such interference when operated in a commercial environment. Operation in a residential area is likely to cause interference which the user must correct at their own expense.

CANADIAN D.O.C. WARNING

This digital apparatus does not exceed the Class A limits for radio noise emissions from digital apparatus set out in the Radio Interference Regulations of the Canadian Department of Communications.

Le présent appareil numérique n'émet pas de bruits radioélectriques dépassant les limites applicables aux appareils numériques de la classe A prescrites dans le Règlement sur le brouillage radioélectrique édicte par le ministère des Communications du Canada.

Trademarks

MONARCH is a registered trademark of Monarch Marking Systems, Inc.
Paxar is a trademark of Paxar Corporation
6010, 6021, 6090, 6092, 6094, 6095, 6096, and Pathfinder are trademarks of Monarch Marking Systems, Inc.

Preface

This manual contains general information about:

- the features and functions of the 6020™ Online Series printers.
- the general operation of the printer.
- the maintenance of the printer.

Models such as the 6021-WP have offline printing capabilities. Refer to the ***Offline Features Manual*** for additional information.

A Format Design Kit is available for information about designing format and label data records. The kit is used primarily by the specialist creating the formats and label data records. The kit contains the manuals listed below:

- ***Programmer's Manual***
- ***Format Reference***

Terms to know

Programming specialist A programmer or individual with programming experience. The specialist will provide the operator format and label data records which will be sent to the printer.

Host system Any mainframe, minicomputer, data terminal, or personal computer.

download (send) Transmitting data from your host system to your printer.

Offline printer Printer with offline printing capabilities.

Cursor Tells which keypad mode you are in:
Regular mode cursor is a solid underline.
Shift mode cursor is a blinking rectangle.

Enter or enter Tells you to input data or information.



Represents the  key on the keypad. Press this key to complete an action or to send data to memory.

Format records Contains a specific label design for printing data.

Label records The data containing the format number and the actual data to be printed on a label.



Represents the  key on the keypad. Press this key to use the functions located on numeric keys.

default Refers to the value already set when you receive the printer. See Chapter 4, about the special operating functions.

How This Manual Is Organized

- Chapter 1** Gives a basic overview about your printer.
- Chapter 2** Tells you what you need to do and know before using the printer.
- Describes how to operate the printer to receive records and print labels.
- Chapter 3** It also describes data entry features available in your model.
- Chapter 4** Provides procedures for using special operating functions.
- Chapter 5** Provides information about the care maintenance of your printer.
- Chapter 6** Contains error messages you may see while using your printer and troubleshooting suggestions.
- Chapter 7** Provides specifications about your printer. It also has a listing of accessories you may use with your printer.

Audience

Operator is the individual printing and applying labels.

Chapters 1, 2, 3, 5, 6, and 7 are for the Operator.

Chapter 4 is for the supervisor setting the options of the printer.

Table of Contents

1. Overview	1
2. Getting Started	3
About the Handle.....	4
Charging Time	4
Low Battery.....	5
Factors Affecting a Charge	5
Charging the Handles.....	6
Loading and Removing a Handle.....	7
Loading and Removing Supplies	8
Loading Supplies.....	8
Removing Supplies	12
The Display.....	13
The Cursor	13
Using Alphanumeric Mode	13
Using the Keypad.....	14
Using the Function Keys	15
3. Printing a Label	17
Receiving Records	18
Receiving Label Data Records.....	19
Receiving Formats Records.....	19
Error Messages	20
Duplicate Formats	20
Sequential Counting.....	21
Sequential Count Multiples.....	22
Helpful Reminders.....	24

4. Special Operating Features	25
Setting the Communication Parameters	26
Date and Time Feature	27
Setting the Date and Time	27
Disabling/Enabling Date and Time Display.....	29
Changing Date and Time Styles	30
Date Format Samples	33
Time Format Samples.....	33
Displaying the Revision Level	34
Sequential Count Multiples	35
Online Interface	36
Currency Selection.....	37
Creating a Check Digit Routine.....	38
5. Care and Maintenance	41
Clearing the Supply and Backing Paper Tracks	41
Checking the Label Chute for Stuck Labels.....	43
Cleaning the Print Head and Platen Roller	44
6. Messages and Troubleshooting	47
Messages	47
Error Messages.....	49
Troubleshooting	50
7. Specifications and Accessories	53
Specifications	53
Accessories.....	53

1. Overview

If you requested custom formats for your printer at the time your printer was ordered, your printer already has formats stored in memory.

If custom formats were ordered, see your management for procedures about using your formats.

If you did not request custom formats, the programming specialist in your company must design formats to be sent to your printer. These formats must be sent to the printer's memory before you begin to print labels.

First, read Chapter 2 for general installation and operating procedures.

2. Getting Started

It is important for you to read this chapter **before** you use the printer. In this chapter you will learn about:

- charging the handles.
- loading supplies.
- the display.
- using the keypad.
- using the function keys.

About the Handle

The printer is powered by a NiCad battery pack in the handle (power module). A NiCad battery lasts approximately two years with average daily use.

When you first receive the printer, you will need to fully charge the handle.

You can charge the handle with a:

- wall charger. ... or ...
- power module charger.

Refer to "Specifications and Accessories" for ordering information.

Charging Time

A full charge takes approximately 8 hours using the wall charger; approximately 1 1/2 hours using the 6094 Power Module Charger. Depending on which power charger you use, it can take 1-5 hours.

CAUTION

Always keep a handle attached to the printer. Storing the printer without a handle may erase or alter the memory.

Make sure you charge the handles for the time recommended.

Low Battery

Anytime you store the printer, keep a handle attached to maintain the memory. However, you may need to recharge the handle **before** the printer can be operated.

While you are using the printer, the printer beeps when the power is low, and displays a message:

RECHARGE

Turn the power off, switch to a fully charged handle, and recharge the used one. To ensure maximum print quality, switch to a fully charged handle for every roll of supply that is printed.

Factors Affecting a Charge

Here are a few factors which affect how long a charge will last.

- The amount of information printed on each label. More energy is required to print a label with 10 fields than to print a label with 4 fields.
- When the handle is not in use and is not recharging, the handle loses 2 - 3% of its charge per day.
- Environments with extreme heat or cold will increase or decrease the discharge rate.

During short term storage, you should keep the handle recharging. This way, the printer is ready for immediate use the next time you need it.

Charging the Handles

This procedure tells you how to charge the handle using the wall charger.

WARNING

Inspect the cord for bare wire **before** each use of the wall charger. Do not use the charger with bare wire.

When using the wall charger or storing it:

- Do not wrap the cord around the transformer.
- Do not pull or put unusual stress on the cord.



To recharge the handle while it is on the printer, push the power switch off. **Do not** use the printer while the handle is charging on the unit.

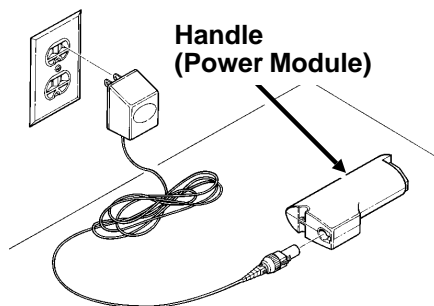

Figure 1

1. Plug the cord of the wall charger into the handle socket (Figure 1).
2. Plug the other end of the cord into a 115V electrical outlet. **A full charge takes approximately 8 hours.** The handle cannot be damaged by overcharging. Therefore, you can leave charged handle plugged in when not in use.



Areas using 220V, 230V, or 240V will receive a wall charger designed for these voltages.

Loading and Removing a Handle

CAUTION

If the power is on while removing the handle, this may erase or alter the memory.

1. Push the power switch off (Figure 2).

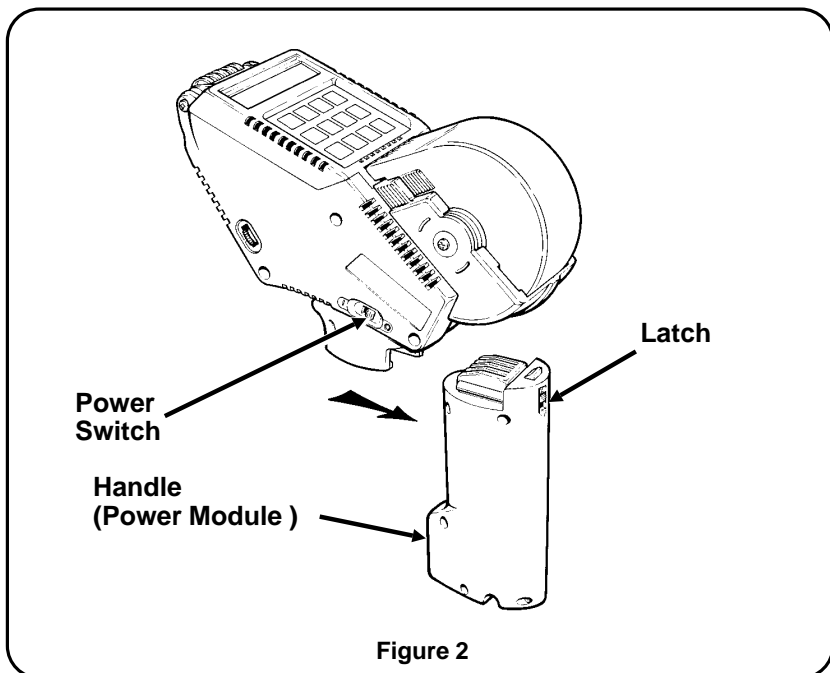

2. Hold the latch down while you slide the handle to the rear and off the printer.
3. Slide a fully charged handle onto the printer until the latch clicks.

Loading and Removing Supplies

The following steps are for the initial loading and removing of supplies (labels).

Loading Supplies

Check your management to see what supply size you need for your printer. If you run out of supplies while printing, leave the power on and skip Step 7.

1. Squeeze the side tabs on the dust cover, and rotate it open until it locks (Figure 3). The hubs will retract in the locked position.

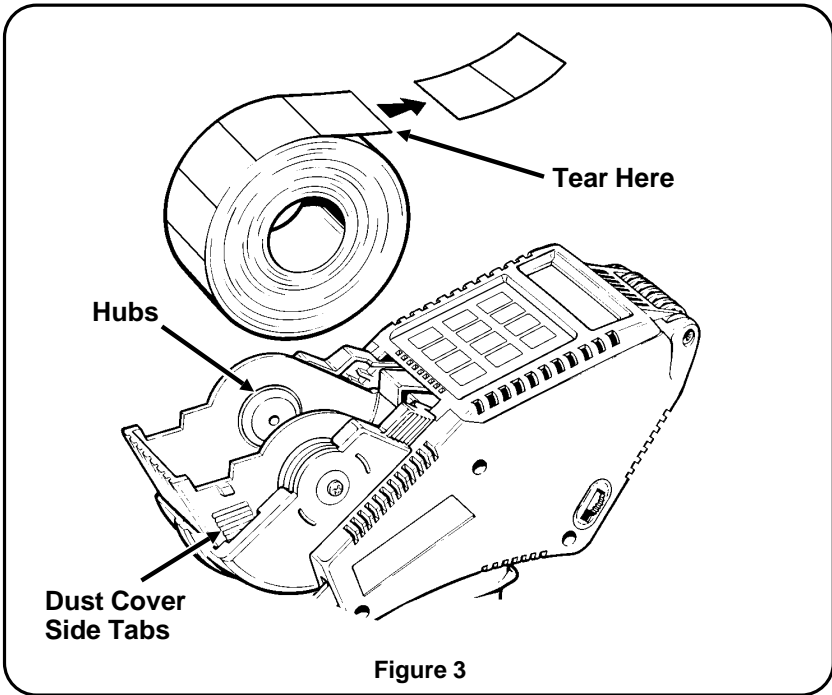

2. Remove the seal from the roll of supplies, and remove the first 10 tags or labels from the backing paper. Tear evenly across the backing paper.

3. Place the roll of supplies between the hubs. Rotate the dust cover forward **slightly**, so the hubs lock into the core of the roll. Make sure the supply turns freely on the hubs.
4. Hold the printer upright. In one quick release action, slide both latch buttons, one on each side of the printer, to the rear (Figure 4). The platen carrier will **partially** open.

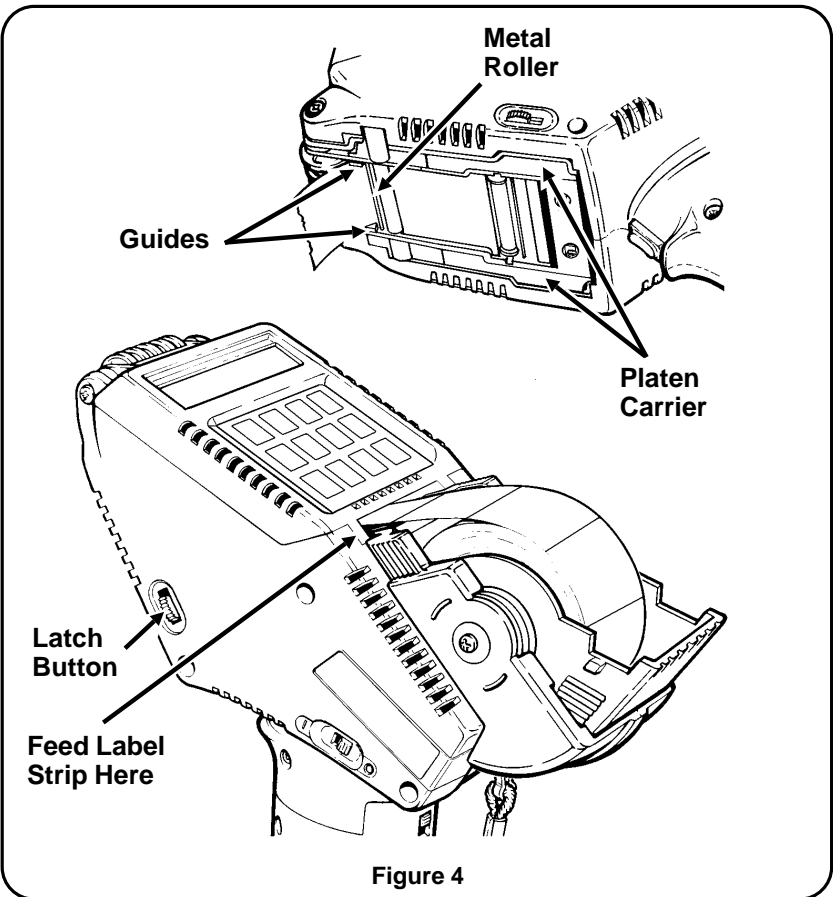

Figure 4

5. Feed the label strip into the printer until it comes out the front and over the metal roller.
6. Close the dust cover completely.

7. Push the power switch on. The display shows a prompt.



If you don't see the **FORMAT?** prompt, press  and start the loading procedure from the prompt.

8. Press  . The display shows:

RELOADING

9. Pull the backing paper down between the guides and against the metal roller (Figure 5).

10. Pull the supply strip until it touches the bottom of the handle.

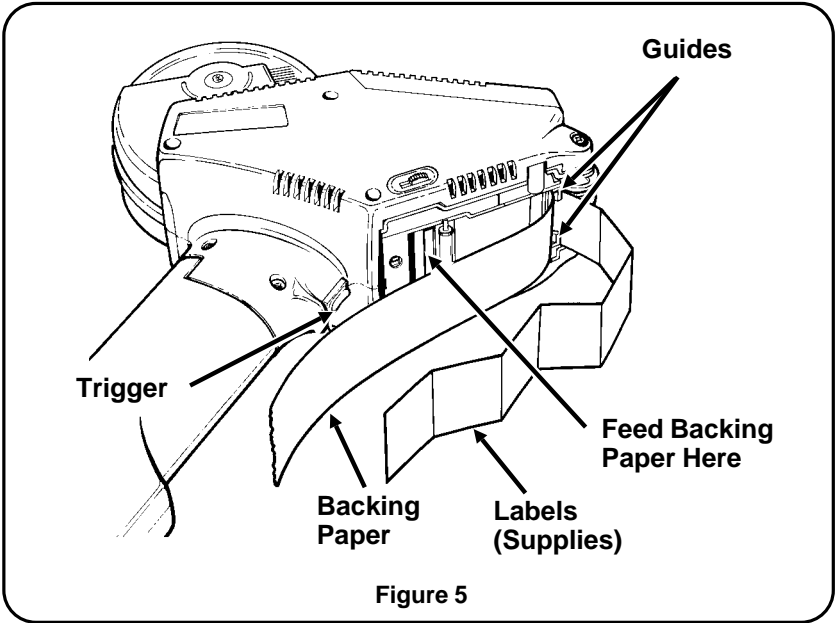

11. Press **both** sides of the platen carrier closed.

12. Separate the supplies from the backing paper.

13. Throw away the separated supplies and any supplies sticking to the backing paper.
14. Feed the backing paper into the slot between the roller and the loading chute.
15. Press the trigger until the backing paper exits the rear of the printer. If the backing paper is not straight, reposition it by applying **light** pressure to hold it in place while pressing the trigger.

If the printer fails to feed the backing paper:

- ✓ Make sure the platen carrier is closed on **both** sides.
- ✓ Make sure the backing paper is threaded between the guides ...or... **CAREFULLY** pull the backing paper out of the slot. Tear evenly across the backing paper and repeat Steps 14 and 15.

If the printer feeds the backing paper, but it does not exit:

- ✓ Make sure the backing paper isn't wadded. Refer to Chapter 5, "Care and Maintenance."

If the label partially exits, press the trigger a few more times. The printer will automatically adjust. If the supply doesn't adjust, reload the supply.

16. Press  to exit. You'll see

SUPPLY? TYPE B

Enter **1** for **TYPE? A** or enter **2** for **TYPE? B**¹. Press . You'll see the **FORMAT?** prompt.

¹ The supply type you enter can be found on the supply carton.

Removing Supplies

1. Open the dust cover until it locks (Figure 6).
2. Tear evenly across the supply strip and remove the roll of supplies.
3. Push the power switch on.



If you don't see **FORMAT?** prompt, press  until you see the prompt.

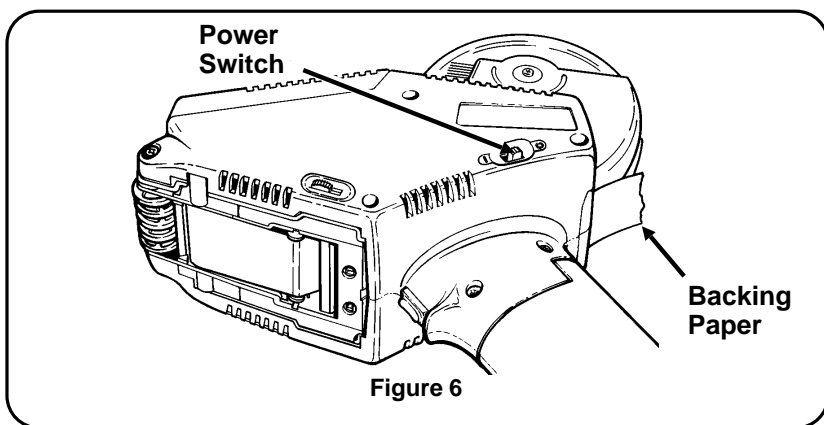





Figure 6

4. Press  . The display shows:

RELOADING

5. Press the trigger to feed the backing paper out through the rear of the printer.
6. Press  to exit. You'll see

SUPPLY? TYPE B

Enter 1 for **TYPE? A** or enter 2 for **TYPE? B**¹. Press . You'll see the **FORMAT?** prompt.

¹ The supply type you enter can be found on the supply carton.

The Display

Your printer has a 16-character one line display that shows prompts, a cursor, and data.

The Cursor

The shape of the cursor tells which mode you are in.

- A solid underline shows when you are in *regular mode*.



- A blinking rectangle (cursor) shows when you are in *shift mode*. You must be in shift mode to use the function keys. See "Using the Function Keys" for more information.



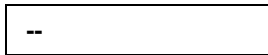

- Two dashes shows when you are in alphanumeric mode.



Using Alphanumeric Mode

Alphanumeric mode uses two digit codes. The alphanumeric code chart is on the cover of your printer. Alphanumeric mode is used in Format 82, "Date and Time." See Chapter 4, "Special Operating Features" for more information.

To use alphanumeric mode:

1. Press  to begin alphanumeric entry.
2. Enter the two digit code, for the two dashes, each letter you want.
3. Press  to exit alphanumeric mode.

Using the Keypad

The keypad consists of numbers and function keys. For online operations you will use the keys listed later in Table 1.

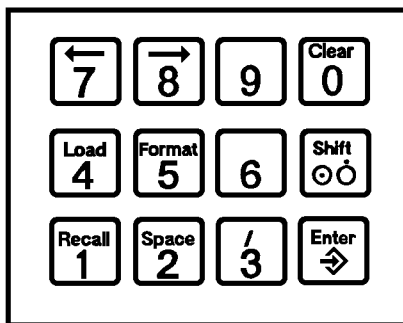

Figure 7. The Keypad

Using the Function Keys

Function keys are used to access special features such as loading supplies. For example,





- At the **FORMAT?** prompt, press  . You will see the message **RELOADING** and a blinking cursor indicating you are in shift mode.
- After you load supplies, press , then  to return to the **FORMAT?** prompt.

Table 1. on the next page tells what action each function key does.





When you press , the printer stays in shift mode, as indicated by the blinking cursor, until the operation is complete. When the operation is complete, the printer will return to regular mode.

Table 1. Function Keys for Online Usage

To use a function, press , then press the function key. For example, press , then press  for the **Clear** function.

Function Key	Description
	<i>Special Operating Features...</i> Erases data from the display as you answer prompts. <i>At supply loading...</i> Exits the loading function.
	Activates the supply loading function.
	Returns you to the FORMAT? prompt. Then you can enter a format number or select a special operating function.
	Places the printer in shift mode so you can use the function keys.



These keys are also used for models with offline printing capabilities. See the *Offline Features Manual* for more information.

3. Printing a Label

Before you can print a label, you must have formats in memory. To receive format and label data records, you must:

- attach a fully charged handle.
- set the communications parameters using Format 81. See "Special Operating Features" for instructions about Format 81.
- connect a cable interface to the host system. See Chapter 7, "Specifications and Accessories" for a list of cables.

The printer will automatically print a label once the data is sent to the printer. A programming specialist will provide the data records you need in the printer.

The remainder of this chapter tells how to receive records from the host system.

Receiving Records



To exit online anytime without destroying data, press  until **FORMAT?** appears at the display.

1. Turn the printer on.
2. You'll see a message indicating the printer is ready to receive records.

WAITING

If you don't see the **WAITING** prompt:¹

- Turn the printer off then on again to see the **WAITING** prompt.

...or...
- Refer to Chapter 4, "Special Operating Features" for instructions on using Format 90 and setting up your printer to receive records.

For instructions on receiving *label data* records, see "Receiving Label Data Records."

For instructions on receiving *format* records, see "Receiving Format Records."

¹ For models with offline printing capabilities, refer to the *Offline Features* manual about power up.

Receiving Label Data Records

You can receive only one label data record at a time. The printer will not store label data records.



You must have formats in your printer before printing a label.

1. At the **WAITING** prompt, send label data from the host system.
2. You'll see **NOT READY** and then **READY** display as the printer processes your data.
3. A label will automatically print. You'll see

PRINTED: 1

4. You can continue to download data when you see **PRINTED: 1**, or press  to exit and return to **FORMAT?**.

See "Error Messages" if your printer detects errors.

Receiving Formats Records

You can send format records as often as you need.

1. At the **WAITING** prompt, send data from the host system. The printer will briefly display a message similar to the one below as the host system downloads records.

RCVG FORMATS

2. You'll see

WAITING

3. You can continue to download data or press  to exit and return to **FORMAT?**.

See "Error Messages" if your printer detects errors.

Error Messages

The printer detects record or communication errors and displays a message. Refer to Chapter 6, "Messages and Troubleshooting," for a listing of messages.

Write down each message as you see it. Then **hold down** the  to clear the message. The **WAITING** prompt will appear. Report the errors to your programming specialist so that they may be corrected.



The printer does not check label data records for errors until you try to print. If the printer detects errors, it displays them when you try to print the label.

Duplicate Formats

If your printer was shipped with custom fixed formats, any downloaded formats with the same format number will temporarily override the custom fixed formats.

If you want to use the fixed formats, a clear command must be sent from the host system. Your programming specialist has instructions for clearing the buffer in the ***Programmer's Manual***.

Sequential Counting

Sequential counting increases or decreases the count on a specific position or group of numbers within a field. This feature may or may not be used in your formats.

When the end count is reached during printing, you will see

***COUNT EXPIRED*.**

Press  and you'll see

PRINTED: 2¹

Press  and you'll see

WAITING

¹ The number of labels printed depends on the value entered for **END COUNT?*** in the format.

Sequential Count Multiples

Sequential count multiples works with sequential count fields and prints multiple labels before incrementing or decrementing the count.

Before you begin receiving records, which uses this feature, Format 86 must be enabled. See Chapter 4, "Special Operating Features" for instructions on using Format 86.

The sample below gives you an idea of how this feature works:

- In the format, sequential count position = **5**
- In the label data record, END COUNT = **3**
- In Format 86, MULTIPLES = **2**

The peripheral printer will print two identical labels for each label data record as sequential count decreases to the number 3.

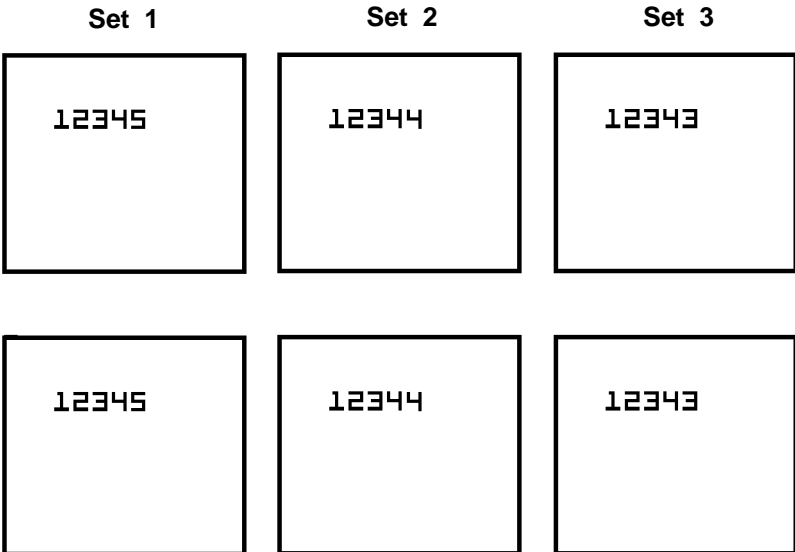

After the number in position 5 reaches 3, the printer stops printing and beeps, then displays

COUNT EXPIRED

Press  and you'll see **PRINTED: 6**

Press  and you'll see

WAITING



If a 0 (zero) is entered for **MULTIPLES?** in Format 86, you'll see

MULTIPLES? 0*

You must enter a multiple label count and press  before you can print.

Helpful Reminders

- Always start with a fully charged handle.
- Attach the safety strap of the printer to your wrist during operations.
- Don't pound the printer when applying labels to items.
- For optimal print quality, Monarch recommends switching to a fully charged handle before loading a new roll of supply.
- Push the power switch off when you are not using the printer.
- Operate and store the printer within the recommended temperature ranges. Refer to Chapter 7, "Specifications and Accessories."
- Charge the handles for the time recommended.

When you are finished using the printer, always:

- ✓ Push the power switch off.
- ✓ Store the printer with the **handle attached**.
- ✓ Fully charge all handles.

4. Special Operating Features

This chapter explains how to use the special features in your printer. The list below shows the feature name, format number, and password.

Feature Name	Format #	Password
Changing Date/Time Styles: Enable/Disable Feature	80	<input type="button" value="Space 2"/> <input type="button" value="Load 4"/> <input type="button" value="Load 4"/>
Set Communication Parameters	81	<input type="button" value="Load 4"/> <input type="button" value="Clear 0"/> <input type="button" value="Recall 1"/>
Setting Date/Time Display	82	<input type="button" value="Space 2"/> <input type="button" value="Space 2"/> <input type="button" value="Load 4"/>
Revision Level	85	None
Sequential Count Multiples	86	<input type="button" value="Space 2"/> <input type="button" value="Clear 0"/> <input type="button" value="Clear 0"/>
Online Interface	90	None
Currency Selection	91	None
Check Digit Routine	93	<input type="button" value="Format 5"/> <input type="button" value="Clear 0"/> <input type="button" value="Clear 0"/>

When you first receive the printer...

Feature Name	Defaults
Communication Parameter	See "Setting the Communication Parameters"
Date/Time display	ENABLED
Sequential Count Multiples	DISABLED
Currency	U.S. CURRENCY

Setting the Communication Parameters

Format 81 allows you to review the current settings for each online option. Then you can accept the current values or change them. Check with your programming specialist for the values required by your host system.

Prompt

What You Do

FORMAT?

Enter **81**, and press .

PASSWORD

Press ,  and .

BAUD RATE? 9600

Enter a number and press .

1 = 300	2 = 600
3 = 1200	4 = 2400
5 = 4800	6 = 9600*

PARITY? SPACE

Enter a number and press .

1 = ODD	2 = EVEN
3 = MARK	4 = SPACE*

XON/XOFF? DSABLE

Enter **1** or **2** and press .

1 = DISABLE*
2 = ENABLE

CNTRL CHR? NOPRN

Enter **1** or **2** and press .

1 = PRINTABLE
2 = NON PRINTABLE*

FORMAT?

The online options are now set. See Format 90 to begin receiving label data records.

* Default value

Date and Time Feature

The date and time feature allows you to set the internal clock and calendar in your printer. You can also change how the date or time displays and prints.

The first thing you must do is set the internal clock with the current date and time. See "Setting the Date and Time." This lets you use date or time for printing if your formats contain these fields.¹

If you need to change the styles for date or time see "Changing Date and Time Styles."

Setting the Date and Time

You must enter the date in month, day and year order (MM/DD/YY). Enter the time in military time (1345 for 1:45 PM). In both cases the punctuation is automatic.

Prompt

FORMAT?

What You Do

Enter **82** and press .

PASSWORD

Press   .

DATE: MM/DD/YY

Enter 2 digits each for the month, day and year. Press .

Example: **021491** and press .

¹ For models with offline printing capability, you can disable the display of this feature if you do not want to see DATE and TIME at power up. See "Disabling/Enabling Date and Time Display."

DAY OF WEEK *

Enter 1-7 for the day of the week.
Press .

- | | |
|---------------|--------------|
| 1 = Monday | 5 = Friday |
| 2 = Tuesday | 6 = Saturday |
| 3 = Wednesday | 7 = Sunday |
| 4 = Thursday | |

Example: Enter **4** for Thursday and
press .

TIME: HH:MM

Enter 2 digits each for hours and
minutes. Press . You'll return to
the **FORMAT?** prompt.

Example: Enter **0915** for 09:15 AM
and press .

Disabling/Enabling Date and Time Display











This session is for models with *offline* printing capability. This feature lets you enable or disable date and time prompt display at power up.



Disabling the date and time display will not affect the internal clock/calendar setting. Also, disabling the display will not interfere with printing the date/time fields on your label.

Prompt

What You Do

FORMAT?	Enter 80 and press  .
PASSWORD	Press  2  4  .
DATE: MM/DD/YY	Press  .
TIME: HH:MM	Press  .
24 HOUR? DISABLE	Press  .
AM/PM? ENABLE	Press  .
DISP ON PWRUP? E	Press  to display D (disable) or  to display E (enable) and press  . Date and Time will not display at power-up.

You'll return to the **FORMAT?** prompt.

Changing Date and Time Styles

When you first receive your printer, the default settings for displaying are:

- MM/DD/YY for date.
- HH:MM for time.
- 24 hour clock (military time) is disabled.
- AM/PM is enabled.
- Display date and time at power up is enabled.

You can change any of these settings as shown below.

Prompt

What You Do



FORMAT?

Enter **80** and press .

PASSWORD

Press  **2**  **4** .

DATE: MM/DD/YY

Press  **00**  **0** to clear the current style. Now use the following alphanumeric codes to enter the new numeric date style. Press . (Maximum of 16 characters.)

22 = M (month digits)

13 = D (day digits)

34 = Y (year digits)



40 = / (slash) -- optional

Reminder.... To begin and end alphanumeric mode, you must press  .

Example: Enter **DDMMYY** and press  to print 240191.

If you want an alphanumeric style, see "Date Format Samples" and use the codes provided on the supply cover.

TIME: HH:MM ****



Press   to clear the current style. Now use the following alphanumeric codes to enter the new style. Press .

- 17 = H (hours)
- 22 = M (minutes)
- 28 = S (seconds)
- 48 = : (colon) -- optional

Reminder.... To begin and end alphanumeric mode, you must press  .

Example: Enter **HHMMSS** and press  for 121436.



24 HOUR? DISABLE

Press  to enable military time style, or press  to skip to the next prompt.





When the 24 hour clock (military time) is enabled, the AM/PM feature is automatically disabled.

AM/PM? ENABLE

Press  to disable AM/PM
or press  to display the next
prompt.

DISP ON PWRUP? E

Press  to disable display of date
and time at power up and press ,
...or...
press  to keep unchanged.

You'll return to the **FORMAT?** prompt.

Date Format Samples

The date samples below use Thursday, January 24, 1991.

Date Style	Displays
MMDDYY or MM/DD/YY	012491 or 01/24/91
DDMMYY or DD/MM/YY	240191 or 24/01/91
YYDDMM or YY/DD/MM	912401 or 91/24/01

*Alphanumeric Dates*¹...

MAA _␣ DD _␣ YYYY	JAN. 24, 1991
WA _␣ MAA _␣ DD _␣ YYYY	TH JAN 24 1991

Time Format Samples

These time samples use 1:30 PM.

Time Style	Displays
HHMMSS or HH:MM:SS	133026 or 13:30:26 (When military time is enabled.)
	013026 or 01:30:26PM (When AM/PM is enabled.)
HHMMSS _␣ or HH:MM:SS _␣	013026 PM or 01:30:26 PM (When AM/PM is enabled.)

¹ The letters M, D, Y, H, S, W and A are reserved letters. To spell out month, use M followed by A for each letter you want to display. To display day of week use W followed by A for each letter you want to display.

␣ = blank space (use   to produce spaces)

Displaying the Revision Level

This feature lets you see the revision level of your software. The first screen shows the kernel revision level; the second screen shows the date and time the software was updated. If you call Monarch Service with a problem, give them the information from both screens.

Follow these steps to display the revision level.

Prompt

FORMAT?

What You Do

Enter **85** and press .

M6021 100712

This example shows that you have a 100712 kernel of 6021. Press  to see the next screen.

5/29/91 12:02:

This screen shows the date and time the software was updated. Press  to see the custom ROM number assigned to your format set.

CUST #10000000

Press  to exit this function. You'll return to the **FORMAT?** prompt.

Sequential Count Multiples

This feature is used for formats that include sequential count fields, and generates multiple labels before increasing/decreasing the count. For example, if you enable Format 86 to print multiples of 5, five labels will print before the sequential count increases or decreases.

To enable sequential count multiples...

Prompt

What You Do

FORMAT?

Enter **86** and press .

PASSWORD

Press  **2**  **0** .

MULT-DISABLE

To enable the sequential count multiples, enter **2**.

MULT-ENABLE

Press .

MULTIPLE?0 - 24

Enter a number from **0 - 24** for the number of multiples you want to print. Press . You'll return to the **FORMAT?** prompt.

To disable sequential count multiples...

Prompt

What You Do

FORMAT?

Enter **86** and press .

PASSWORD

Press  **2**  **0** .

MULT-ENABLE

Press **1** to disable sequential count multiples. Press . You'll return to the **FORMAT?** prompt.

Online Interface

This feature lets you set your printer in receiving mode if you decide to download more formats and label data records. The printer is ready to receive records when you see the **WAITING** prompt.

Reminder... Connect the printer to the host system with a cable interface. See Chapter 7, "Specification and Accessories" for more information.

Prompt

What You Do

FORMAT?

Enter **90** and press .

WAITING

Send records from the host system.

See "Receiving Records" for procedures about receiving format and label data record.

Currency Selection

This function lets you select a currency format for price fields or information fields.

Prompt

FORMAT?

CURRENCY?

What You Do

Enter **91** and press .

Enter **1-12**, then press . Return to the **FORMAT?** prompt. Currency options are:

- 1 = DOLLAR
- 2 = DEUTCHMARK
- 3 = POUND
- 4 = KRONA
- 5 = FRANC
- 6 = MARKA
- 7 = SCHILLING
- 8 = LIRA
- 9 = PESETA
- 10 = NO SYMBOL (3 digits after decimal)
- 11 = YEN
- 12 = NO SYMBOL (2 digits after decimal)

Creating a Check Digit Routine

The printer lets you design your own check digit routine. You must define the check digit routine *before* entering a format that requires a customer check digit.

Prompt

What You Do

FORMAT?

Enter **93** and press .

PASSWORD

Press  **5**  **0**  **0**.

RECORD #?

Enter **1-10** for the record number of the check digit routine. Press .

MODULUS 2-11?

Enter any value **2-11** for the modulus number, press .

Example: To select modulus **3**, enter **3** and press .

DIGITS 2-15?

Enter any value **2-15** for the number of data characters in the field, excluding the check digit. Press .

Example: For a 5-digit code, enter **5** and press .

METHOD?

Select **1** for sum of digits ...or... select **2** for sum of products.

METHOD? S. DIGIT

Press **1** and the .



Prompt

ENTER WEIGHTS**

What You Do

Enter values **0-9** for the multiplier.
Press .

Example: Enter **13131** and
press .

To exit, press   when you see the **RECORD #?** prompt.
This saves your check digit routine and displays the **FORMAT?**
prompt.

5. Care and Maintenance

This chapter contains:

- Clearing the Supply and Backing Paper Tracks
- Checking the Label Chute for Stuck Labels (when using label supplies only)
- Cleaning the Print Head and Platen Roller

Clearing the Supply and Backing Paper Tracks

1. Push the power switch off.
2. Squeeze the tabs (Figure 8) on the dust cover and rotate it open until it locks.
3. Remove the roll of supply.

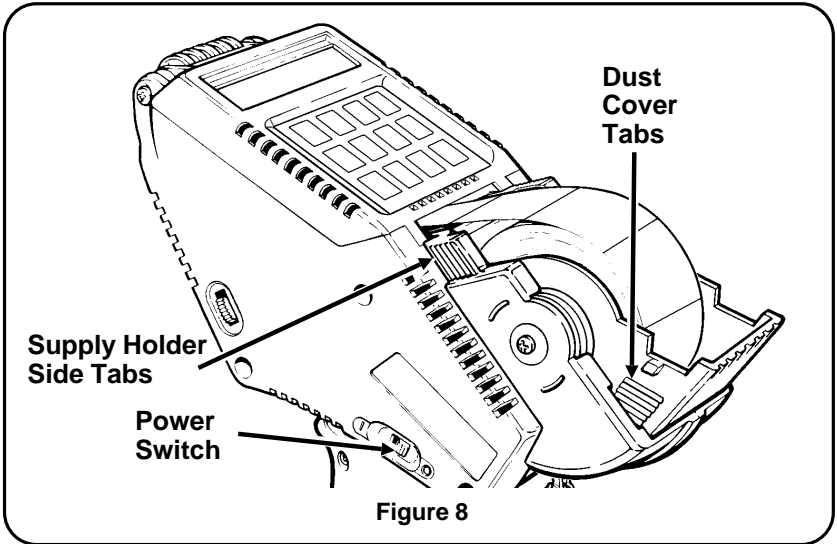

Figure 8

4. Squeeze the side tabs on the supply holder and rotate it open.

5. Check the supply and backing paper tracks (Figure 9).



The motor may be hot.

- If the backing paper is wadded, tear the backing paper. Carefully pull the wadded paper out through the front of the printer. Remove any labels stuck in the track. Reload the supplies.
- If the backing paper is free, lift it and remove any labels stuck in the track.

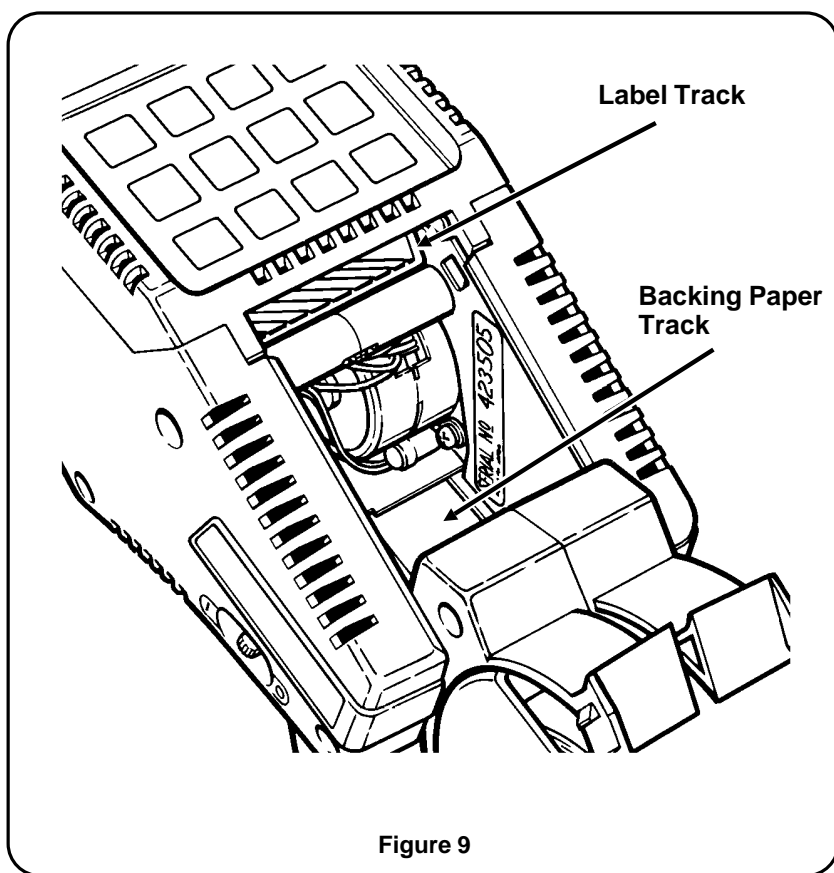

Figure 9

6. Close the supply holder and squeeze the side tabs to secure it.

Checking the Label Chute for Stuck Labels

Hold the printer in an upright position. Slide the latch buttons (Figure 10) on each side of the printer to the rear with one quick release action. The platen carrier will **partially** open.

1. Slide the buttons to the rear again, the platen carrier will open **completely**.
2. Remove any stuck labels.

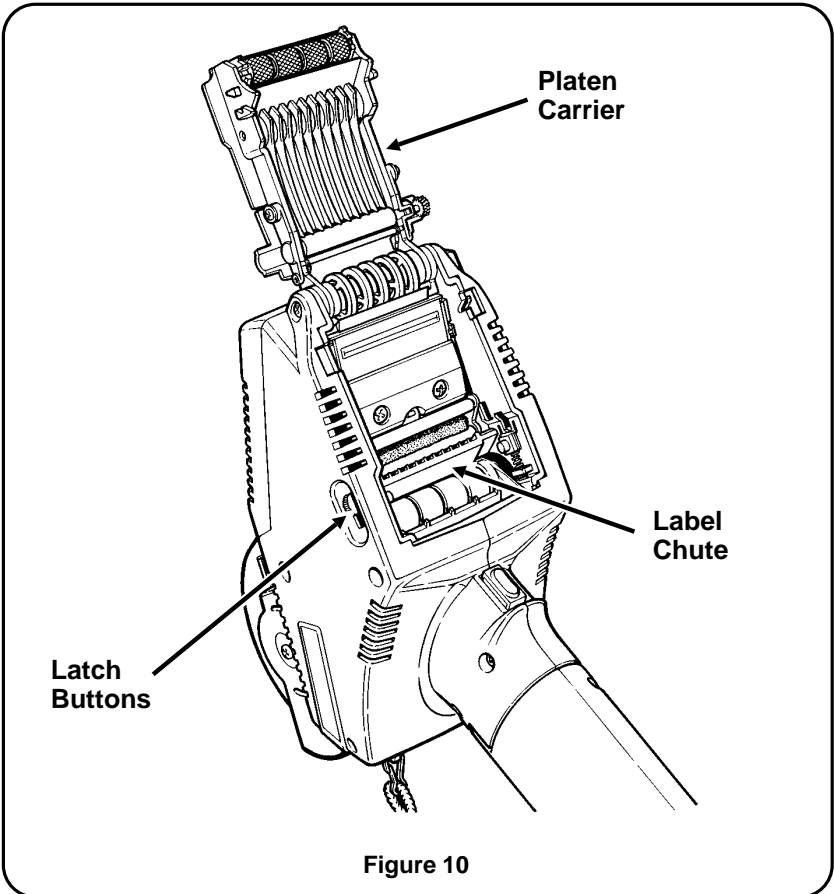

3. Press **both** sides of the platen carrier closed.

Cleaning the Print Head and Platen Roller

Clean the print head :

After 7-10 rolls of standard supplies.

- ✓ In high temperature or humid conditions.
- ✓ When you see voids in the print (Figure 11).

In excessively dirty environments or with heavy usage, clean the print head and supply holder more often.

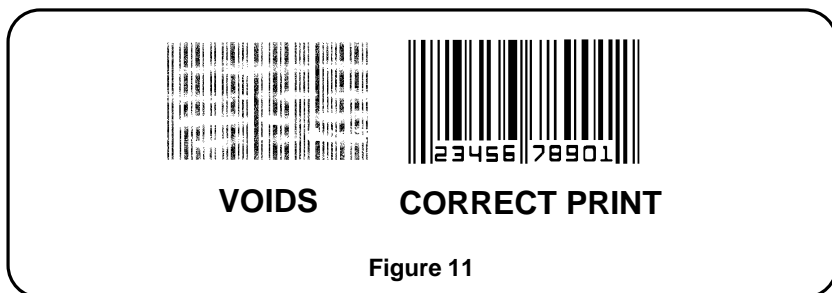

Monarch recommends using the Pathfinder 6076™ Cleaning Kit and reading the instructions **before** cleaning.

1. Remove the roll of supplies. Check the supply holder for adhesive buildup, and clean with isopropyl alcohol.
2. Slide both latch buttons (Figure 12) to the rear twice and release them to **completely** open the platen carrier.

CAUTION

DO NOT use sharp objects to remove adhesive or label particles from the green print head area. This may damage the print head and void your warranty.

3. Check the platen roller and carefully remove any stuck labels or adhesive buildup.

CAUTION

Use isopropyl alcohol only on the interior areas, never on the exterior parts of the printer. **DO NOT** use silicon to clean or lubricate.

4. Lightly moisten a soft cloth with alcohol.
5. Clean the print head area (Figure 12) of all adhesive and label particles.
6. Also clean the platen roller and other surfaces that are shown. Special instructions are included in the 6076 Cleaning Kit.

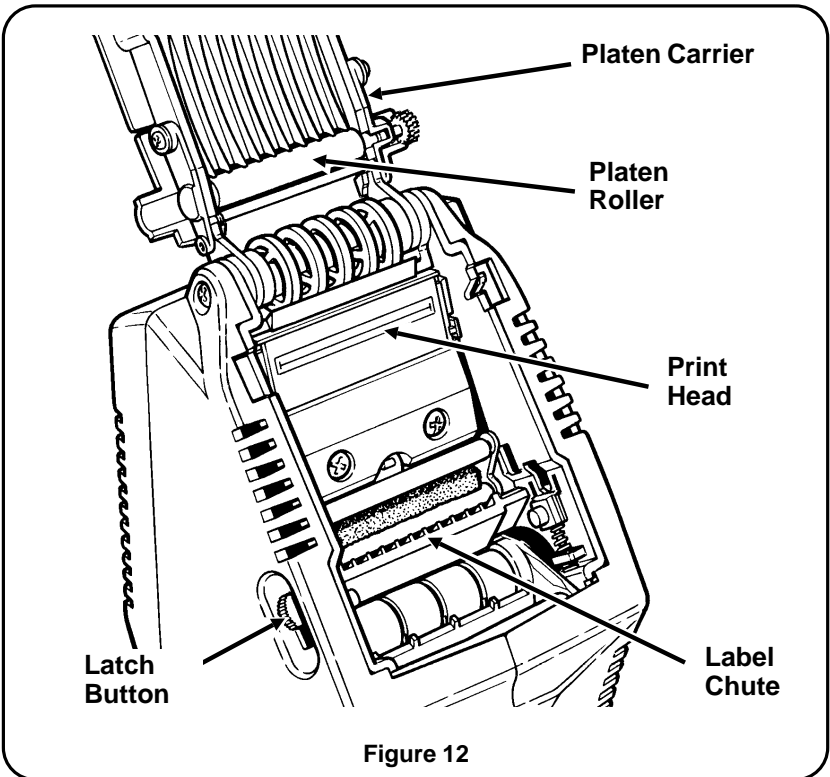



Figure 12



7. Press **both** sides of the platen carrier closed.

6. Messages and Troubleshooting



This section contains both informative and error type messages. If you cannot fix a problem, please contact Monarch Service.

Messages

To clear a message from the screen, press  .

Message	Corrective Action
COMM ERROR	Hold down the  key until you see WAITING or FORMAT? .
	The transmission of data was not successful. Check communication parameters set in the host system and the printer.
	Incorrect syntax in the format structure.
DATA ERROR	Transmission of label record not successful.
COUNT EXPIRED	The printer has reached the end count for sequential counting. Press   to continue printing. Refer to Chapter 3, "Printing a Label" for more information.
END COUNT?	This prompt asks for the ending number of count. For information about sequential counting see Chapter 3, "Printing a Label".
FORMAT UNDEFINED	The format number you selected is not in memory. Retry, making sure the label data contains the correct format number.

Messages (continued)

Message	Corrective Action
<p>OVERHEAT (when the power is first turned on)</p>	<p>Ensure that you are operating or storing the printer within the recommended temperature listed in the specifications.</p>
	<p>Contact Monarch Service.</p>
<p>OVERHEATED-WAIT (while printing labels)</p>	<p>Let the printer cool for a few seconds. You don't have to turn the printer off. When the printer is cool, the display shows PRINTED. You may begin printing.</p>
	<p>If the message still appears. Contact Monarch Service.</p>
<p>PAPER JAM</p>	<p>Press   to clear the message.</p>
	<p>Check the label and backing paper tracks per the maintenance instructions.</p>
	<p>Reload the supplies if necessary.</p>
	<p>The label size set in the format does not match the supply you have loaded. Load the correct supply.</p>
<p>RECHARGE</p>	<p>Turn the power off and replace the handle with a fully charged handle.</p>
	<p>Recharge the used handle.</p>
<p>SERVICE REQUIRED</p>	<p>Contact Monarch Service.</p>
<p>STRIP LENGTH?</p>	<p>For offline printing models. Refer to the Offline Features.</p>

Error Messages

1. When you see one of the messages listed below, make note of the message.

ERROR - FFD8	ERROR - FFDA	ERROR - FFDC
ERROR - FFE0	ERROR - FFE8	ERROR - FFE2
ERROR - FFEA	ERROR - FFEC	ERROR - FFEE
ERROR - FFF0	ERROR - FFF2	ERROR - FFF4
ERROR - FFF6	ERROR - FFF8	ERROR - FFFA
ERROR - FFFC		



2. Turn the power off, then on. If the problem has not cleared, call Monarch Service.

Troubleshooting

If you cannot fix a problem, please contact Monarch Service.

Problem	Corrective Action
No print on the supply.	Make sure both sides of the platen carrier are closed.
	Make sure the supplies are loaded correctly.
	There may be an error in the format. Check with the programming specialist.
Bad print or partial print on supply.	Make sure the supplies are loaded correctly.
	Check the supplies for damage or defects.
	Reload new supplies if necessary.
	Check platen roller for stuck labels per maintenance instructions.
	Clean the print head.
	Turn the power off and switch to a fully charged handle.
	Make sure both sides of the platen carrier are closed.
	There may be an error in the format. Check with the programming specialist.
Printer prints on part of the supply, and fails to respond to the keyboard or trigger. RECHARGE does not appear in the display.	Turn the power off and switch to a fully charged handle.
	Make sure the labels are loaded correctly.

Problem	Corrective Action
Printer fails to respond to the keyboard, during data entry. RECHARGE does not appear in the display.	Turn the power off and switch to a fully charged handle.
Handle does not hold a charge, or the handle doesn't fully charge when recharged.	<p>Generally, switch handles only when you see RECHARGE, or when there is no charge in the battery.</p> <p>Call Monarch Sales and Service.</p>
Printer will not feed.	Turn the power off and switch to a fully charged handle.
	Make sure the platen cover is completely closed.
	Check for correct supply stock that is black marked.
	Reload the supplies.
	Check the label and backing paper tracks per instructions.
Slow or sluggish supply feeding.	Make sure the supplies are loaded correctly.
	Check the label and backing paper tracks per instructions.
Handle won't charge.	Make sure the handle is connected correctly.
	Make sure the charger is plugged into a live outlet.
	Clean the printer per instructions.
No display.	Make sure the power switch is on.
	Turn the power off and switch to a fully charged handle.

Problem	Corrective Action
Printer will not print.	Turn the power off and switch to a fully charged handle.
	Make sure the supplies are loaded correctly.
Print has voids or is too light.	Make sure the supplies are loaded correctly.
	Make sure <i>both</i> sides of the platen carrier are closed.
	Turn the power off and switch to a fully charged handle.
	Clean the print head per maintenance instructions.
Lock up occurs when you enter FORMAT 100-109	Press   to clear the display. Re-enter the correct format number.

7. Specifications and Accessories

Specifications

Weight:	1.98 lbs. (.89 kg)
Storage and Operating Limits:	40°F to 104°F (4°C to 43°C)
Battery Power:	12 volt; charging takes approximately 8 hours, 1 power module (handle) with a wall charger. - 6090 Charger takes approx. 5 hours. - 6094 Charger takes approx. 1 1/2 hours.
Printing:	Thermal direct with thermally coated paper (no ink or ribbon required)
Display:	16-character (one line) alphanumeric liquid crystal display
Memory:	3.6 volt lithium battery maintains memory

Accessories

- 6010 Table Top Accessory
- 6090 Eight Station Charger
- 6094 Four Station Charger
- 6092-04 Wall Charger
- 6095-02 AC Adaptor
- 6096 Cable Interface
- PHOL-01 Holster
- TC6021FMKT Format Reference/Programmer's Manual

For more information about these products, call your Monarch Sales Representative.

Index

A

Accessories 53
Alphanumeric 13
Alphanumeric mode 13

B

Backing paper
 clearing 41
Battery
 NiCad 4
Battery charge
 factors affecting 5
Battery handle 4 - 5, 7
 charging 4, 6
 charging time 4
 loading 7
 low 5
 removing 7
Baud Rate
 communication parameters 26

C

Charging
 battery 4, 6
Check digits
 creating a routine 38
 Format 93 38
 password 38
Cleaning
 platen roller 44
 printhead 44
Clearing backing paper 41
Clearing supplies 41
Communication Parameters
 baud rate 26
 control characters 26
 parity 26
 setting 26
 XON/XOFF 26
Control characters
 communication parameters 26
Count expired 21
Currency selection
 Format 91 37
 password 37
Cursor 13

D

Date 27
 disable 29
 enable 29
 password 27
 sample 33
 setting 27
 style 30
Defaults
 special operating features 25
Display 13
Duplicate formats 20

E

Error messages 20, 49

F

Format 85
 revision level 34
Format 86
 sequential count
 multiples 22, 35
Format 90
 receiving records 36
Format 91
 currency selection 37
Format 93
 check digits 38
Format records
 receiving 19
Function Keys
 using 15

H

Handle
 loading 7
 removing 7
Helpful Reminders 24

K

Keypad 14

L

Label data records
 receiving 19
Labels
 loading 8
 removing 12
 stuck 43

M

Maintenance 39
Messages 47

O

Online Printing 18
Overview 1

P

Parity
 communication parameters 26
Password
 check digits 38
 currency selection 37
 date and time 27
 sequential count multiples 35
Passwords
 special operating features 25
Platen roller
 cleaning 44
Printhead
 cleaning 44
Printing 18

R

Receiving records 18
 Format 90 36
 formats 19
 label data 19
Revision Level
 display 34
 Format 85 34

S

Sample
 date and time 33
Sequential count multiples
 Format 86 22, 35
 password 35
Sequential counting 21
Special Operating Features 25
 defaults 25
 passwords 25
Specifications 53
Stuck labels 43
Style
 date and time 30
Supplies
 loading 8
 removing 12
Supply
 clearing 41

T

Time 27
 disable 29
 enable 29
 password 27
 sample 33
 setting 27
 style 30
Troubleshooting 47, 50

X

XON/XOFF
 communication parameters 26

For supplies, service, or assistance in Switzerland call:

Tel: 021 869 97 70

Fax: 021 869 96 02

e-mail: info@gomaro.ch

Web: www.gomaro.ch