

MICROSCAN[®]

MS-7100/7180 Industrial Scanner User's Manual

MS-7100



MS-7180



Information and specifications in this manual are subject to change without notice.

Copyright © 1998

by Microscan Systems, Inc.,
1201 S.W. 7th Street, Renton, Washington, U.S.A. 98055
(425) 226-5700 FAX: (425) 226-8682

All rights reserved. The information contained herein is proprietary and is provided solely for the purpose of allowing customers to operate and/or service Microscan manufactured equipment and is not to be released, reproduced, or used for any other purpose without written permission of Microscan.

Throughout this manual, trademarked names might be used. Rather than put a trademark (™) symbol in every occurrence of a trademarked name, we state herein that we are using the names only in an editorial fashion, and to the benefit of the trademark owner, with no intention of infringement.

Microscan Limited Warranty Statement and Exclusions

What is Covered?

Microscan Systems Inc. warrants to the original purchaser that products manufactured by it will be free from defects in material and workmanship under normal use and service for a period of one year from the date of shipment. This warranty is specifically limited to, at Microscan's sole option, repair or replacement with a functionally equivalent unit and return without charge for service or return freight.

What is Excluded?

Any products or parts that have been subject to misuse, neglect, accident, unauthorized repair, improper installation, or abnormal conditions or operations. Any products or parts that have been transferred by the original purchaser. Customer mis-adjustment of settings contrary to the procedure described in the Microscan owners manual. Upgrading software versions at customer request unless required to meet specifications in effect at the time of purchase. Units returned and found to have no failure will be excluded. Claims for damage in transit are to be directed to the freight carrier upon receipt.

THIS EXPRESS WARRANTY EXCLUDES ALL OTHER WARRANTIES, EXPRESS OR IMPLIED, INCLUDING BUT NOT LIMITED TO, IMPLIED WARRANTIES OF MERCHANTABILITY AND FITNESS FOR PURPOSE. MICROSCAN SYSTEMS INC. SHALL NOT BE LIABLE FOR ANY SPECIAL, INCIDENTAL, OR CONSEQUENTIAL DAMAGES, WHETHER IN CONTRACT, TORT, OR OTHERWISE.

Some states do not allow the exclusion or limitation of incidental or consequential damages or limitations on an implied warranty, so the above limitation or exclusion may not apply to you. This warranty gives you specific legal rights, and you may also have other rights which may vary from state to state.

The buyer acknowledges that he/she is not relying on the seller's skill or judgment to select or furnish goods suitable for any particular purpose and that there are no warranties that extend beyond the description on the face hereof.

Before Requesting Service...

Please check the owners manual for proper setup and cabling procedures and any customer settings for mis-adjustment for your particular application. Correcting these may save you a service call.

To receive Warranty Service...

Contact your nearest Microscan Service Center at the address shown below for a Return Material Authorization (RMA) number before returning product. Receipt of an RMA number is not an admission of warranty status. All product must be returned freight prepaid to the location issuing the RMA number before the expiration of the warranty period.

Table of Contents

| | |
|---|------|
| List of Illustrations | v |
| List of Tables..... | vi |
| About the MS-7100 Scanner..... | vii |
| About this Manual | vii |
| Keystroke Entries..... | vii |
| Approvals | viii |
| Warning and Caution Summary..... | viii |
| Safety Labels | ix |
| | |
| Chapter 1 Setup and Installation | |
| Step 1 - Plan Scanning System | 1-2 |
| Step 2 - Verify Read Range | 1-3 |
| Step 3 - Estimate Scan Width | 1-4 |
| Step 4 - Determine Raster Height and Arc (7180) | 1-5 |
| Step 5 - Calculate Number of Scans..... | 1-6 |
| Step 6 - Attach Cabling | 1-8 |
| Step 7 - Configure Scanner | 1-13 |
| Step 8 - Position Scanner and Label | 1-14 |
| Step 9 - Test and Autocalibrate | 1-15 |
| Step 10 - Adjust Other Scanning Parameters..... | 1-16 |
| Step 11 - Install Scanner..... | 1-18 |
| Operational Tips..... | 1-19 |
| | |
| Chapter 2 Menu Configuration | |
| Entering the Menu Configuration Program | 2-2 |
| Using the Menu Configuration Program | 2-2 |
| Saving Menu Changes | 2-4 |
| Loss of Communications | 2-4 |
| Defining Special Characters | 2-4 |
| Communications Menu | 2-5 |
| Operations Menu | 2-12 |
| Code Types Menu..... | 2-22 |
| User Outputs Menu..... | 2-31 |
| Raster Setup Menu | 2-37 |
| | |
| Chapter 3 Serial Configuration | |
| Summary of Serial Configuration Commands..... | 3-2 |
| Communications Commands..... | 3-5 |
| Operations Commands | 3-9 |
| Code Type Commands | 3-12 |
| User Outputs Commands | 3-15 |
| Raster Setup Commands..... | 3-17 |

| | | |
|------------|---|------|
| Chapter 4 | Calibration | |
| | About Calibration | 4-2 |
| | Autocalibration | 4-2 |
| | By Serial Command | 4-2 |
| | By Menu Command | 4-3 |
| | Other Menu Parameters | 4-5 |
| | Recalling Factory Settings | 4-6 |
| | Saving Current Settings | 4-6 |
| | Motor Speed | 4-6 |
| | Gain | 4-7 |
| | Tracking | 4-8 |
| | Bandwidth | 4-8 |
| | Clock Speed | 4-8 |
| | Bar Size Measurements | 4-9 |
| | Scan Rate | 4-9 |
| Chapter 5 | Operational Commands | |
| | Summary of Operational Commands | 5-2 |
| | Program Management Commands | 5-3 |
| | Device Control Commands | 5-3 |
| | Code Type Commands | 5-4 |
| | Counter Commands | 5-4 |
| | Test Commands | 5-5 |
| | Status Commands | 5-5 |
| | Master Label Commands | 5-5 |
| Appendices | | |
| | Appendix A — Scanner Specifications | A-2 |
| | Appendix B — ASCII Table | A-5 |
| | Appendix C — Orientation | A-6 |
| | Appendix D — Ground and Shield Considerations | A-9 |
| | Appendix E — Defaulting the Scanner | A-10 |
| | Appendix F — Troubleshooting | A-11 |
| | Appendix G — Bar Code Symbology | A-14 |
| | Appendix H — Interface Standards | A-15 |
| | Appendix I — Auxiliary Monitor | A-16 |
| | Appendix J — Multidrop Communications | A-21 |
| | Appendix K — Glossary of Terms | A-25 |

List of Illustrations

| | |
|---|------|
| Figure 1-1 System Diagram | 1-2 |
| Figure 1-2 MS-7100/7180 Ranges and Scan Widths | 1-4 |
| Figure 1-3 MS-7180 Raster Height | 1-5 |
| Figure 1-4 Rear Panel | 1-8 |
| Figure 1-5 Host Connector | 1-9 |
| Figure 1-6 DTE Host Connections | 1-10 |
| Figure 1-7 Trigger Connection | 1-11 |
| Figure 1-8 Trigger Input Diagrams (untriggered) | 1-11 |
| Figure 1-9 Power Connector | 1-12 |
| Figure 1-10 MS-7100 Orientation | 1-14 |
| Figure 1-11 MS-7180 Orientation | 1-14 |
| Figure 1-12 Bottom Mounting Holes of MS-7100 (not to scale) | 1-18 |
| Figure 1-13 Bottom Mounting Holes of MS-7180 (not to scale) | 1-19 |
| Figure 2-1 Configuration Program - Main Menu..... | 2-2 |
| Figure 2-2 Communications Menu Structure | 2-5 |
| Figure 2-3 Operations Menu Structure | 2-12 |
| Figure 2-4 External Level Trigger Signals | 2-14 |
| Figure 2-5 External Edge Trigger Signals | 2-14 |
| Figure 2-6 Code Types Menu Structure | 2-22 |
| Figure 2-7 User Outputs Menu Structure | 2-31 |
| Figure 2-8 Raster Setup Menu Structure | 2-37 |
| Figure 2-9 Raster Sweep Arc | 2-37 |
| Figure 4-1 Calibration Setup Menu | 4-5 |
| Figure A-1 Scanner Dimensions | A-2 |
| Figure A-2 Scan Range | A-4 |
| Figure A-3 Ladder Orientation | A-6 |
| Figure A-4 Picket Fence Orientation | A-6 |
| Figure A-5 Angled Picket Fence Orientation | A-7 |
| Figure A-6 Detector Side Orientation | A-7 |
| Figure A-7 Detector Right-Angle Orientation | A-8 |
| Figure A-8 Label Dimension | A-8 |
| Figure A-9 Raster Image | A-8 |
| Figure A-10 Grounding Diagram, Scanner-Host | A-9 |
| Figure A-11 Host Connector Default Pins | A-10 |
| Figure A-12 Typical Multidrop Network | A-21 |
| Figure A-13 Polling Sequence | A-22 |
| Figure A-14 Select Sequence | A-23 |

List of Tables

| | |
|--|------|
| Table 1-1 MS-7100/7180 Read Range and Scan Widths | 1-3 |
| Table 1-2 Cable Distances | 1-8 |
| Table 1-3 Host 28-pin Connector Pin Assignments | 1-9 |
| Table 1-4 Trigger Connector Pin Assignments | 1-11 |
| Table 1-5 Power Connector Pin Assignments | 1-12 |
| Table 2-1 Symbology Identifier Option Values..... | 2-23 |
| Table 2-2 Raster Settings | 2-37 |
| Table 3-1 Summary of Serial Configuration Commands | 3-2 |
| Table 3-2 Protocol Commands | 3-6 |
| Table 5-1 Operational Commands..... | 5-2 |
| Table A-1 ASCII Table with Control Characters | A-5 |
| Table A-2 Troubleshooting | A-11 |
| Table A-3 Multidrop Address Characters | A-24 |

About the MS-7100/7180 Scanner

The MS-7100 and the MS-7180 are fixed-mount industrial laser diode scanners enclosed in sealed cases. They employ brushless ball-bearing motors to spin 14-sided mirrors at 1000 scans per second to read and decode barcode labels at a wide variety of ranges. The MS-7180 includes a controllable stepper motor and raster mirror to create a scan pattern over a broad two-dimensional area.

About this Manual

This manual provides complete information on setting up, installing, and configuring the MS-7100 and the MS-7180 industrial scanners.

Chapter 1 provides overall step-by-step instructions for setting up and installing the scanner with specific “go to” references to other chapters and appendices.

Chapter 2 provides instructions for configuring the scanner by menu.

Chapter 3 provides instructions for configuring the scanner by serial command.

Chapter 4 provides instructions for using the Calibration Setup menu.

Chapter 5 describes the serial operational commands that can be sent from the host.

For specifications, see appendix A. The appendices also include reference tables as well as other useful information relating to bar coding and the scanner.

Note: *Bar code labels should meet minimum ANSI (American National Standards Institute) standards as specified in ANSI Bar Code Print Quality Guideline, X3.182-1990.*

Keystroke Entries

Keystrokes to be entered from your terminal are highlighted in bold, as in <D>, including a < left angle bracket symbol (unless redefined by Command Start Character command) and followed by a > right angle bracket symbol.

Approvals

- CDRH (Center for Devices and Radiological Health)
- TÜV (Technischer Überwachungs-Verein)
- CE
- cUL (Underwriters Laboratories, Inc.)
- FCC (Federal Communications Commission) Part 15, Class A
- This Class A digital apparatus meets all requirements of the Canadian Interference-Causing Equipment Regulations.

Cet Appareil numérique de la classe A respecte toutes les exigences du Règlement sur le matériel brouilleur du Canada.

Warning and Caution Summary

Caution: *This equipment has been tested and found to comply with CISPR 22 and with the limits for a Class A digital device, pursuant to part 15 of the FCC Rules. These limits are designed to provide reasonable protection against harmful interference when the equipment is operated in a commercial environment. This equipment generates, uses, and can radiate radio frequency energy, and, if not installed and used in accordance with the instruction manual, may cause harmful interference to radio communications. Operation of this equipment in a residential area is likely to cause interference in which case the user will be required to correct the interference at his or her own expense.*

For connection to a Listed direct plug-in power unit marked Class II and rated at 10 to 28 VDC unregulated power @10 watt maximum.

Safety Labels

Note: *The safety labels will carry a CDRH Class II designation when placed on an MS-7100 or MS-7180 with 670 nm visible light.*

**WARNING**

Use of controls, adjustments, or performance of procedures other than those specified herein may result in hazardous laser light radiation exposure. For connection to a listed direct plug-in power unit market Class 2 and rated 5 VDC/200mA.

**WARNING**

There are no user serviceable parts in the MS-7100/MS-7180 scanner. Opening the scan head voids the Microscan Systems warranty and could expose the user to laser diode power of up to 5 mW.

**WARNING**

The laser beam can be harmful to eyesight. Avoid eye contact with the laser beam. Never point the beam at other people, or in a direction where people may be passing.

The following label is found on the top of the MS-7100 and MS-7180:

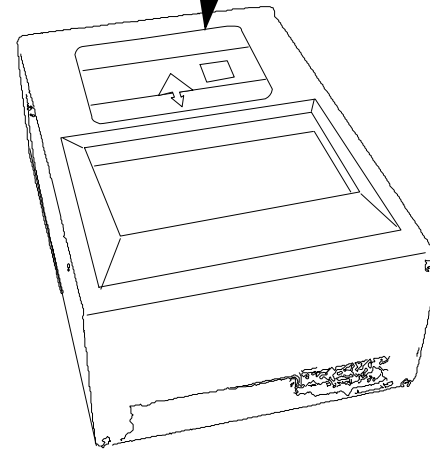
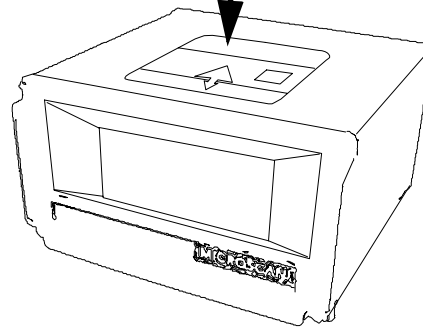
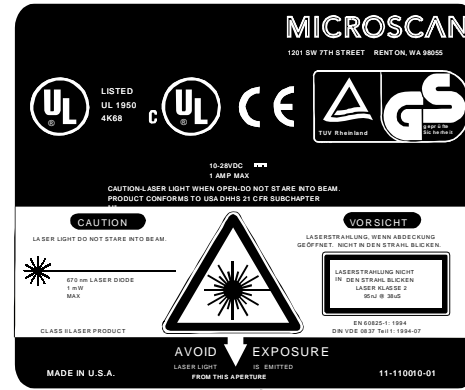
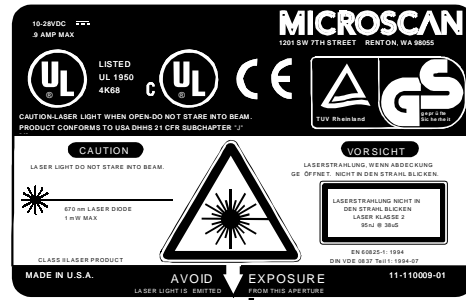

Chapter 1

Setup and Installation

Chapter Contents

| | |
|---|------|
| Step 1 - Plan Scanning System | 1-2 |
| Step 2 - Verify Read Range | 1-3 |
| Step 3 - Estimate Scan Width | 1-4 |
| Step 4 - Determine Raster Height and Arc (7180) | 1-5 |
| Step 5 - Calculate Number of Scans..... | 1-6 |
| Step 6 - Attach Cabling | 1-8 |
| Step 7 - Configure Scanner | 1-13 |
| Step 8 - Position Scanner and Label | 1-14 |
| Step 9 - Test and Autocalibrate | 1-15 |
| Step 10 - Adjust Other Scanning Parameters..... | 1-16 |
| Step 11 - Install Scanner..... | 1-18 |
| Operational Tips..... | 1-19 |

This chapter provides step-by-step instruction for setting up and installing the MS-7100 or MS-7180 scanner to obtain optimum read rates.

1 Plan Scanning System

Before installing the industrial scanner you should sketch out a diagram of your scanning system, showing equipment, connector and cable types, and cable lengths.

Figure 1-1 shows a possible scanning system setup. There are three cable connectors on the scanner: the 28-pin host connector (see [figure 1-5 on page 1-9](#)) the 9-pin trigger connector (see [figure 1-7 on page 1-11](#)) and the 9-pin power connector (see [figure 1-9 on page 1-12](#)).

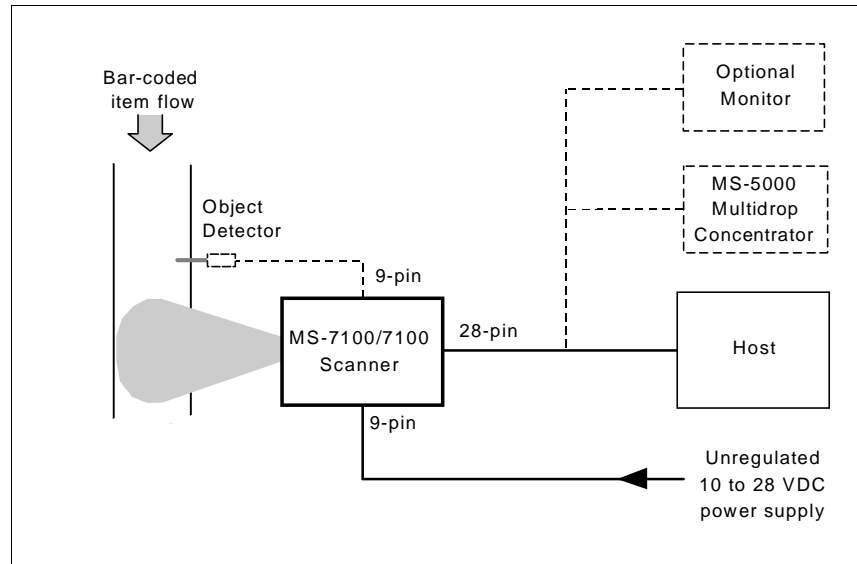

Figure 1-1 System Diagram

2 Verify Read Range

Table 1-1 shows readable ranges and maximum scan widths for specific bar code density (narrow-bar-width) types. Use this table as a reference to verify that the planned range for your label falls within one of the listed ranges.

Table 1-1 MS-7100/7180 Read Range and Scan Widths

| Narrow-Bar-Width | Read Range ^a | | Maximum Scan Width | |
|--------------------------|------------------------------|-------------------------------|--------------------|-----------------|
| | MS-7100 | MS-7180 | MS-7100 | MS-7180 |
| Low Density ^b | | | | |
| .020" | 6" to 23" (15.2 to 58.4 cm) | 4" to 20" (10.2 to 50.8 cm) | 13" (33.0 cm) | 12" (30.5 cm) |
| .030" | 4" to 34" (10.2 to 86.4 cm) | 2" to 32" (5.1 to 81.2 cm) | 18" (45.7 cm) | 16" (40.6 cm) |
| .040" | 10" to 44" (25.4 to 112 cm) | 8" to 42" (20.3 to 106.7 cm) | 25" (63.5 cm) | 22.5" (57.2 cm) |
| .050" | 10" to 55" (25.4 to 140 cm) | 8" to 50" (20.3 to 127 cm) | 34" (86.4 cm) | 31" (78.8 cm) |
| High Density | | | | |
| .010" | 6" to 11" (15.2 to 27.9 cm) | 4" to 8.5" (10.2 to 21.6 cm) | 7.5" (19.1 cm) | 7" (17.8 cm) |
| .015" | 5" to 16" (12.7 to 40.6 cm) | 3" to 13.5" (7.62 to 34.3 cm) | 10.5" (26.7 cm) | 9.5" (24.1 cm) |
| .020" | 3" to 16" (7.6 to 40.6 cm) | 1" to 14" (2.54 to 35.6 cm) | 10.5" (26.7 cm) | 9.5" (24.1 cm) |
| .030" | 4" to 20" (10.2 to 50.8 cm) | 2" to 18" (5.1 to 45.7 cm) | 13.5" (34.3 cm) | 13" (33 cm) |
| .040" | 4" to 20" (10.2 to 50.8 cm) | 4" to 18" (10.2 to 45.7 cm) | 13.5" (34.3 cm) | 13" (33 cm) |
| Ultra High Density | | | | |
| .005" | 2" to 4.25" (5.1 to 10.8 cm) | 1" to 3.5" (2.54 to 8.9 cm) | 3.25" (8.3 cm) | 2.25" (5.7 cm) |
| .0075" | 2" to 5" (5.1 to 12.7 cm) | 1" to 3.5" (2.54 to 8.9 cm) | 3.75" (9.5 cm) | 2.5" (6.4 cm) |

- a. Read range is the distance of the label from the scanner (measured from the front of the scanner bezel) in which the label can be reliably read. The distance between the minimum and maximum ranges is the depth of field.
- b. FIS (Final Instruction Sheet) option.

Note: Optimum read rates can be expected at the center of the depth of field (half-way between minimum and maximum read range) for a given bar code density.

For information on label orientation, see [Appendix C, "Orientation,"](#) on page A-6.

3 Estimate Scan Width

Scan width is that portion of the scan line in which a label can be read. For ladder oriented labels, scan width must only be wide enough to fully cover the label length, including quiet zones. With picket fence oriented labels, scan width is a factor in determining the time during which the label can be read. (See [Appendix C, "Orientation,"](#) on page A-6) The greater the scan width, the longer a picket fence label will be in the scan range, and the more scans it will receive.

Use [figure 1-2](#) to estimate the scan width that corresponds to the applicable read range. For example, a picket fence label moving across the scan line at 43 inches (109 cm) from the scanner will have a scan width of approximately 33 inches (83.8 cm).

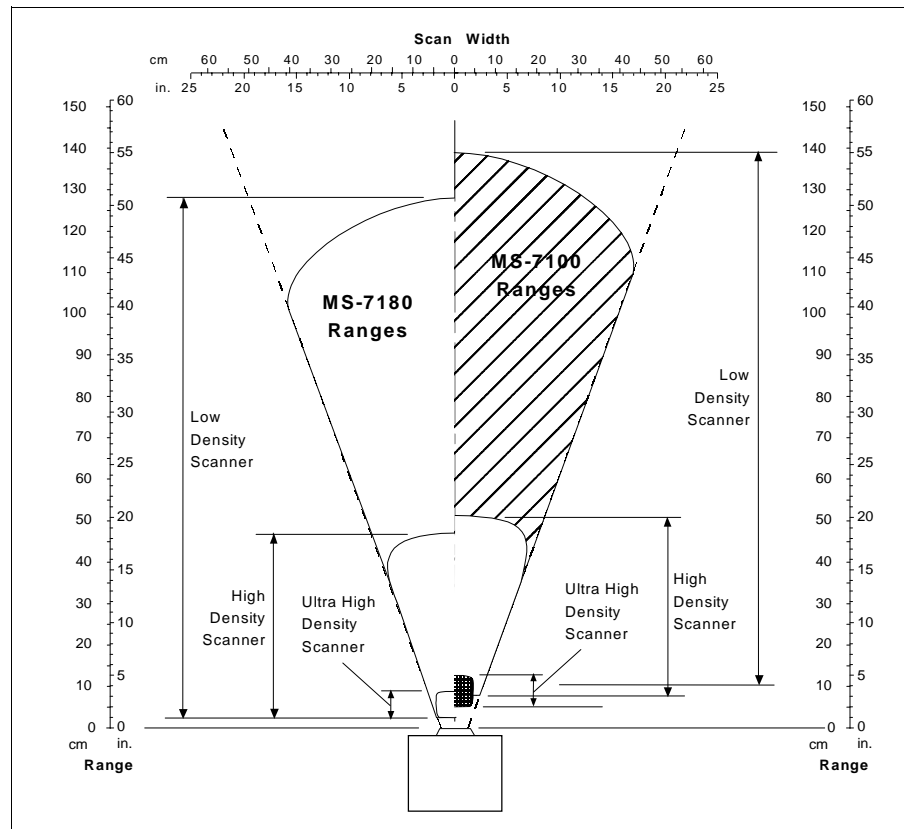

Figure 1-2 MS-7100/7180 Ranges and Scan Widths

4 Determine Raster Height and Arc

(MS-7180 only)

In setting up the MS-7180 raster scanner, raster height depends on the raster arc and label distance (range) from the scanner. In [figure 1-3](#) raster height and raster arc are shown at their maximum with raster arc set to 45°. Both the top offset and bottom offsets can be adjusted independently in one-degree increments and the resulting arc can vary from 0° to 45°. (See “[Raster Setup Menu](#)” on [page 2-37](#).)

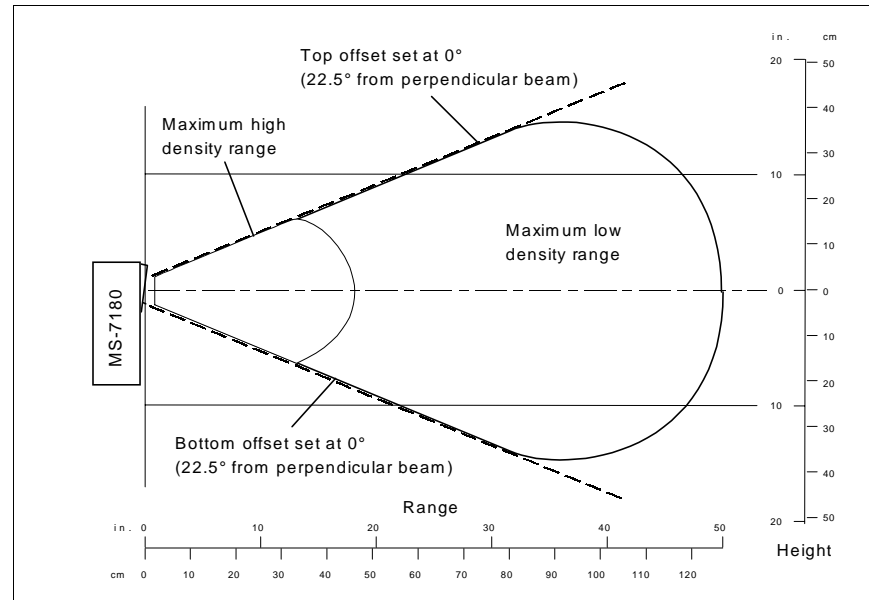

Figure 1-3 MS-7180 Raster Height

Raster Height. If raster arc and label range are known, raster height can be derived by the following formula where \emptyset is raster arc in degrees:¹

$$RH = (2 \times ScanRange) \tan\left(\frac{\emptyset}{2}\right)$$

Raster Arc. If raster height and label range are known, the raster arc can be derived by using the following formula where RH is raster height:

$$\emptyset = 2 \cdot \text{atan}\left(\frac{RH}{2 \times ScanRange}\right)$$

1. Raster Height and Raster Arc formulas assume a straight-on symmetrical arc.

5 Calculate Number of Scans

To ensure reliable scanning, we recommend that you apply a minimum of *five* scans to each label. Use the formulas below to calculate the number of scans that your label will receive.

If the number of scans you derive from one of these calculations is less than the minimum for your application, plug in the minimum number of scans and solve for another parameter that might be changed, such as label speed or scans per second (SPS).

See [Appendix C, "Orientation,"](#) on page A-6 for explanation of ladder, picket fence, and label characteristics.

MS-7100

Ladder Calculation

$$\left(\frac{LH}{LS} \times SR\right) - 3 = \text{number of complete scans} \quad 1$$

Where LH = Label Height, LS = Label Speed, and SR = Scan Rate.

Example: If $LH = 1$, $LS = 10$, and $SR = 1000$, then the number of scans will equal 97.

Picket Fence Calculation

$$\left(\frac{SW - LL}{LS} \times SR\right) - 3 = \text{number of complete scans} \quad 1$$

Where SW = Scan Width, LL = Label Length,

LS = Label Speed and SR = Scan Rate

Example: If $LL = 2$, $LS = 10$, $SW = 8$, and $SR = 1000$, then the number of scans will equal 597.

Angled Picket Fence Calculation

The number of complete scans for angled picket fence is calculated the same as that for picket fence, with the exception that the scan width is shortened in proportion to scan tilt.

1. The -3 component is added to allow for AGC acquisition and for incomplete first and last scans. This applies only if the calculation in the brackets is 3 or more. If it equals 2, then subtract only 1, giving 1 good scan.

MS-7180

Ladder Calculation

Ladder scanning is rarely done with raster scanners and when it is, it is generally done with a stop and go label. In such a situation the number of scans is equal to the scan rate times the number of seconds the label pauses under the raster image (adjusted by the ratio of raster height to label height).

Picket Fence Calculation

For picket fence raster scanning, number of scans (NS) is arrived at by first solving for sweeps per second (SPS).

Sweeps per Second (SPS) is the user-programmable number of raster sweeps that transpire in a second. A **sweep** is defined as a single pass, up or down, describing the raster image. Sweeps per second should generally be as few as possible in order to maximize the number of scans applied to a given label and to minimize wear on the raster parts and vibration to the scanner.

The formula for finding **Sweeps Per Second (SPS)** is as follows:¹

$$SPS = \frac{2 \times LS}{(SW - LL)}$$

Since SPS can only be entered into the software (see [“Raster Setup Menu” on page 2-37](#)) as whole numbers, round off fractions of SPS to the next higher number, for example enter 0.4 as 1 and 3.5 as 4.

Number of Scans (NS) be calculated by the following formula:²

$$NS = \frac{LH \times SR}{RH \times SPS} - 3$$

Example: If SW = 10, LL = 2, and LS = 2, then SPS will equal 0.5. Since 0.5 is less than one, we will assign a value of one in the Sweeps per Second option as described in [“Raster Setup Menu” on page 2-37](#) and in the NS formula which (with LH = 1, SR=400, RH = 10, and SPS = 1) calculates out to 37 complete scans.

1. The number 2 in the SPS formula is a constant that doubles the number of sweeps to ensure that each label receives two full raster sweeps.
2. The -3 component is added to allow for AGC acquisition and for incomplete first and last scans. This applies only if the calculation in the brackets is 3 or more. If it equals 2, then subtract only 1, giving 1 good scan.

6 Attach Cabling

The scanner (figure 1-4) has three I/O connectors on the rear panel which accept circular, twist-lock, sealed socket connectors. The center 9-pin trigger connector is covered with a removable dust cap.

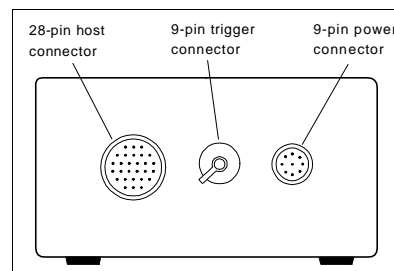

Figure 1-4 Rear Panel

A connector kit (P/N 98-200003-01) is included with your scanner. The kit contains a 9-pin socket connector kit (P/N 200002-01), a 28-pin cable connector kit (P/N 98-200001-01), and related pins, clamps, screws, and dust seals.

Use the 28-pin connector kit (P/N 98-200001-01) as part of your host cable assembly for connection with the 28-pin socket connector. (See table 1-3 on page 1-9.)

Use the 9-pin socket connector (P/N 98-200002-01) to mate with the 9-pin power connector (see “Power Connector” on page 1-12) or if desired, with the 9-pin trigger connector (see “Trigger Connector” on page 1-11).

Note: The 9-pin cable connector kit (P/N 98-200002-01) will mate with either the power connector or the trigger connector.

Under ideal conditions, maximum cable lengths can meet the distances shown in table 1-2. However, since cable lengths and sizes are dictated by local conditions such as wire size, shielding, grounding, extraneous signal noise, etc., maximum cable distances will vary.

Table 1-2 Cable Distances

| Cabling | Maximum Distance |
|------------------------|------------------|
| RS-232 Scanner to Host | 50' (15.2 m) |
| RS-422 Scanner to Host | 4000' (1219 m) |
| RS-485 Multidrop Trunk | 4000' (1219 m) |
| RS-485 Multidrop Drop | 10' (3 m) |

Several pins are repeated on different connectors. For example, you can apply power optionally through the host or trigger connector, as well as the power connector. You can also use pins 7 and 9 of either the trigger or power connectors to route current through internal relay contacts which open or close according to user-determined conditions (a noread, a match, or a mismatch). The same pulse that drives this internal relay sends a TTL pulse (high or low) to pin 6 on the host and pins 8 of both the trigger and power connectors. If no data is decoded, a noread pulse is output to pin 6 of the host connector. (See “Relay Settings” on page 2-32.)

Host Connector.

The host connector is a 28-pin circular twist-lock connector as shown in [figure 1-5](#) (Amp CPC series) that mates with a supplied 28-pin socket connector (P/N 98-200001-01). It allows the scanner to be connected to a host, a concentrator, or other communications device such as a PLC (programmable logic controller), a monitor, a PC, a relay, a diverter, an alarm, etc.

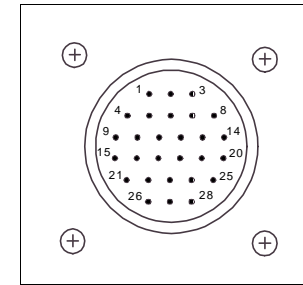

Figure 1-5 Host Connector

Pins 6, 8, and 25 (table 1-3) can be used to drive a small relay to operate an alarm, diverter, etc. A pulse will be sent to pin 8 at the occurrence of any noread. Outputs to pins 6 and 25 are programmable (see [“Relay Settings”](#) on page 2-32). You can also control voltage level ([“Output Polarity”](#) on page 2-33) and duration of pulses ([“Output Pulse Width”](#) on page 2-33) for all three pins (6, 8, and 25).

Table 1-3 Host 28-pin Connector Pin Assignments

| Pin | Function | Pin | Function |
|-----|--|-----|--|
| 1 | Chassis ground | 15 | TXD + (RS-422/RS-485) ^a |
| 2 | Transmit data (RS-232) | 16 | TXD – (RS-422/RS-485) |
| 3 | Receive data (RS-232) | 17 | Reserved |
| 4 | Request to send (RS-232) ^b | 18 | Aux transmit data (RS-232) |
| 5 | Clear to send (RS-232) | 19 | Aux receive data (RS-232) |
| 6 | Relay--output #1 ^c (see page 2-32) | 20 | Power ground |
| 7 | Signal ground (RS-232) | 21 | RXD + (RS-422/RS-485) |
| 8 | Noread Output (see page 2-17) ^c | 22 | RXD – (RS-422/RS-485) |
| 9 | +5 VDC out (100 mA max.) | 23 | Reserved ^b |
| 10 | Trigger input (0 VDC to +24 VDC) | 24 | Reserved ^b |
| 11 | +12 VDC out (50 mA max.) | 25 | TTL--output #2 ^c (see page 2-33) |
| 12 | –12 VDC out (20 mA max.) | 26 | Default config. (see page A-10) |
| 13 | Signal ground | 27 | New Master (see page 2-34) |
| 14 | Power input (10 to 28 VDC unreg.) | 28 | CPU master reset ^d |

a. See your multidrop manual for multidrop cabling and termination requirements.

b. The default communications mode does not support pin 4 (RTS). If RTS and CTS are not required by the host port, pins 4 and 5 should not be wired as the results will be unpredictable.

c. Source or sink 4 mA.

d. Bringing pin 28 to ground resets the CPU, clears all buffers, and restores all parameters that have been saved to nonvolatile memory.

Chapter 1 Setup and Installation

Figure 1-6 shows two minimum host connections for RS-232 communications using the supplied 28-pin socket connector shown on the left.

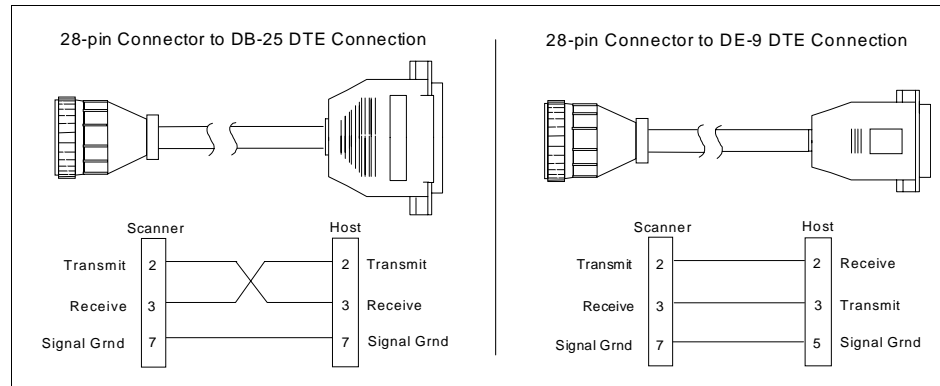

Figure 1-6 DTE Host Connections

Caution: Do not use a host cable with more wires connected than are required for the application. The host connector of the scanner has many outputs that could cause damage or interfere with normal operation if connected and improperly used.

Note: All Microscan products are configured as DTE at the host connector when in RS-232 operation.

Trigger Connector¹

The scanner's trigger connector (figure 1-7) is a 9-pin, circular, twist-lock type that mates with a Microscan socket connector (P/N 98-200002-01) (not supplied with the scanner). Trigger pin assignments are listed in table 1-4.

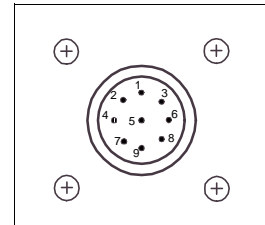

Figure 1-7 Trigger Connection

A programmable pulse to internal relay contacts will make or break connection between pins 7 and 9 for external use (up to 200 mA or 4 VA).

Table 1-4 Trigger Connector Pin Assignments

| Pin | Function |
|-----|---|
| 1 | Power ground |
| 2 | Supply +12 VDC (out) @ 50 mA |
| 3 | Optional power input to the scanner (10 to 28 VDC unreg.) |
| 4 | Trigger Input from the object detector (3 to 24 VDC) |
| 5 | Power ground |
| 6 | Optional power input to the scanner (10 to 28 VDC unreg.) |
| 7 | Relay contact 1, (200 mA or 4 VA) |
| 8 | Relay-output #1 (source or sink 4 mA) (see table 1-3) |
| 9 | Relay contact 2 (200 mA or 4 VA) |

Figure 1-8 shows examples of positive and negative external trigger inputs that could be applied to the trigger port. (Shown in the untriggered state.)

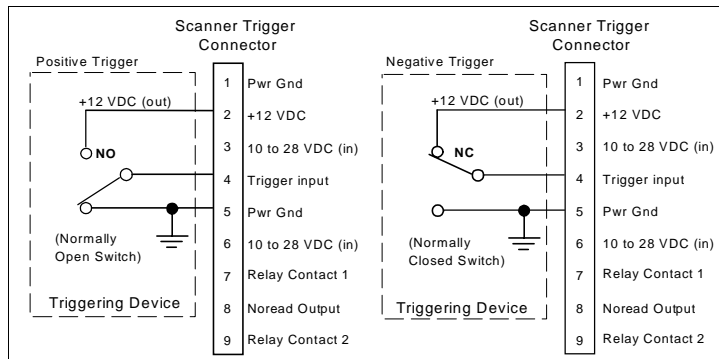

Figure 1-8 Trigger Input Diagrams (untriggered)

1. Microscan offers an object detector for this connector (P/N 99-440001-03). Other trigger sources can also be used. Mechanical switches, relays, etc.—which tend to be slow and bouncy and produce multiple trigger signals—are not recommended unless equipped with optical sensors or filtered transitions (optical, Hall effect, or DC solid state relays).

Power Connector

The power connector (figure 1-9) is a 9-pin, circular, twist-lock connector (Amp CPC series) that mates with a supplied 9-pin socket connector (P/N 98-200002-01). The pin assignments are listed in table 1-5.

Note: Trigger and host connectors can also supply power.

Pins 1, 3, 6, 7, 8, and 9 are identical to those of the trigger connector.

Pins 2 and 4 provide access to the scanner for the auxiliary RS-232 port and are similar to pins 18 and 19 of the host 28-pin connector.

Pin 5 is internally connected to pin 1 of the host connector and to the external case to provide a path for electrostatic discharge or AC faults to pass directly to ground. It is intended to be connected to a “safety ground” (also known as “green-wire” or “third wire” ground). It is particularly useful in installations where the case is not grounded through its mounting plate or when this connection must be guaranteed even when the unit is unmounted. This connection allows hazardous currents, such as electrostatic discharge or AC faults, to pass safely to ground instead of traveling through the unit’s circuits or signal cabling.¹

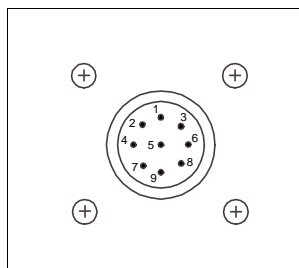

Figure 1-9 Power Connector

Table 1-5 Power Connector Pin Assignments

| Pin | Function |
|-----|---|
| 1 | Power ground |
| 2 | Aux. transmit (RS-232) |
| 3 | Power input 10 to 28 VDC unreg. @ 9W max. with less than 1 V p-p ripple |
| 4 | Aux. receive data (RS-232) |
| 5 | Chassis ground |
| 6 | Power input 10 to 28 VDC unreg. @ 9W max. with less than 1 V p-p ripple |
| 7 | Relay contact 1, (200 mA or 4 VA) |
| 8 | Relay--output #1 (source or sink 4 mA) |
| 9 | Relay contact 2 (200 mA or 4 VA) |

1. Note that the path established by pin 1 of the host connector, which goes through the host cable shield, is not effective for this purpose.

7 Configure Scanner

Settings for Communications, Operations, Code Types, and User Outputs are stored in nonvolatile memory and can be configured from a host or auxiliary terminal by menu (Chapter 2, “Menu Configuration”) or by serial command (Chapter 3, “Serial Configuration”).

For explanations of configuration settings, see Chapter 2, “Menu Configuration.”

To establish communication you will need to match the host’s or auxiliary terminal’s communication settings with your scanner’s settings (see “Communications Menu” on page 2-5). Also make certain that the code type enabled in the scanner matches that of the label being used (see “Code Types Menu” on page 2-22).

Hint: Enabling Autodiscrimination in the menus (or with the <P> command) will allow your scanner to read all of the listed code types.

Communicating with an ASCII Terminal

The scanner communicates in full duplex, terminal mode with no handshake. It also recognizes carriage returns and line feeds.

The host or ASCII terminal with must match the following default settings before any communication can take place: 9600 Baud Rate, Seven Data Bits, Even Parity, and One Stop Bit.

A PC or Macintosh computer can be used as an ASCII terminal if connected as shown under “Host Connector” and running a communications program set to the above defaults. See your computer manual for communication’s port pinouts.

8 Position Scanner and Label

Before testing and calibrating, you will need to position the scanner and label in a manner that matches as nearly as possible the actual conditions of your application.

- a. Position the scanner and label, taking care to avoid excessive tilt, skew, or pitch.¹
- b. Pitch label slightly as shown in figures 1-10 and 1-11 to avoid *specular reflection*, the return of direct, non-diffused light.²

Another way to avoid specular reflection is to skew the scanner slightly in relation to the label.

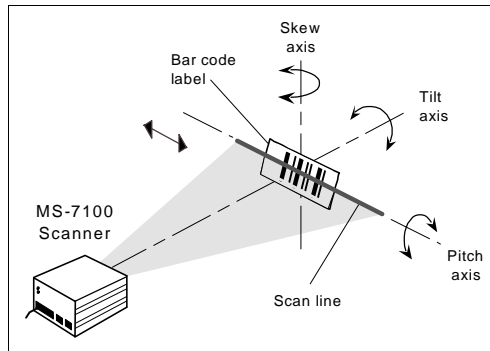

Figure 1-10 MS-7100 Orientation

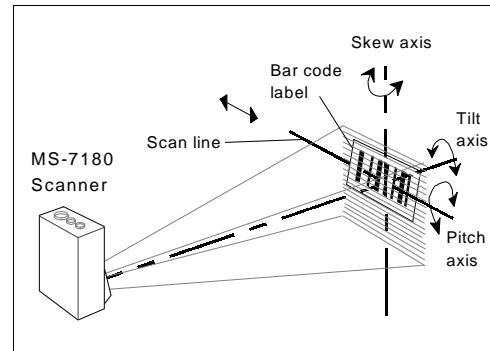

Figure 1-11 MS-7180 Orientation

For more information, See [Appendix C — “Orientation”](#) on page A-6.

1. Maximum tilt is determined by label characteristics and number of scans required. Maximum skew is $\pm 40^\circ$; maximum pitch is $\pm 50^\circ$.
2. The specular reflection zone is a narrow zone straight out from the scanner in which direct reflected light from a label can distort the scanner's ability to distinguish bars from spaces. For the MS-7100 scanner, specular reflection is avoided by pitching labels at least 1.5° at ranges from 0 to 20 inches (50.8 cm) from the scanner, and thereafter at diminishing angles, for example, 0.75° at 40 inches (101.6 cm), and 0.5° at 60 inches (152 cm). For the MS-7180 raster scanner, specular reflection is avoided by pitching labels at least 5° from a line perpendicular to the raster mirror.

9 Test and Autocalibrate

If your proposed scanning range is not within the range specified in [table 1-1 on page 1-3](#), go to step e.

If your proposed scanning range is within the range specified in [table 1-1 on page 1-3](#), test read rate by doing the following:

- a. Position the label in front of a functioning scanner and launch the read rate test with a <C> command from the host terminal. (See [“Status Commands” on page 5-5](#).)
- b. Observe read rate. (Read rate is the percentage of scans decoded.)
- c. Check depth-of-field (minimum/maximum range) by moving the label closer and further relative to the scanner and noting the points where the read rates fall below a level acceptable to your application.

Ideally, the label used in your application should pass through or near the center of the depth-of-field.
- d. Repeat steps a through c for other labels used in your application and end the read rate test with a <J> command.

If the read rate is acceptable, go to [Step 11, “Install Scanner,” on page 1-18](#).

If the read rate is not acceptable, continue with the following steps:

- e. Do Autocalibration (see [Chapter 4, “Calibration.”](#)) and check Read Rate within the Calibration program.

(Autocalibration optimizes the read rate by automatically cycling through the gain and tracking settings and selecting the combination that achieves the highest read rate.)
- f. If the results are not satisfactory after doing Autocalibration, go to [Step 10, “Adjust Other Scanning Parameters,” on page 1-16](#).

Important: *If, after Autocalibration or other adjustments you have changed the read range or other parameter used in the number of scans formula, you should recalculate the Number of scans ([Step 5, “Calculate Number of Scans,” on page 1-6](#)).*

Note: *Variations between labels are common. For this reason, the greater number of sample labels you test, the more likely you are to achieve optimum read rates.*

10 Adjust Other Scanning Parameters

Autocalibration (in [step 9](#)) is the preferred method of increasing read rate. However, you might need to adjust other scanning parameters as well. This section lists various adjustments (other than Autocalibration) that may improve read rates.

After changing any of the parameters described in this section,

- a. If applicable, recalculate the number of scans ([Step 5, “Calculate Number of Scans,”](#) on page 1-6).
- b. Repeat [Step 9, “Test and Autocalibrate,”](#) on page 1-15 (if adjusting Gain or Tracking, omit sub-steps e and f).¹
- c. Compare the new read rate results with those obtained before changes were made.

Scan Rate

Scan Rate is a function of motor speed and adjustable from within the Calibration Setup menu. The scanner is factory set at the upper rate of 1000 scans per second (sps), although it can be user adjusted to as low as 600. A slower scan rate may allow greater label range and/or higher read rates, but at the cost of fewer scans per label.

For example, if you have calculated that a label in your application will receive 98 scans with a scan rate of 1000 sps, then slowing the scan rate to 800 sps will diminish the number of scans the label will receive to 78, a number that should be well above your minimum.

To adjust scan rate (motor speed), send the <↳> command to the scanner and follow the screen cues. For more information, see [“Motor Speed”](#) on page 4-6.

Range

Adjusting the label's range, if possible, is one of the quickest and most effective ways to improve read rates. However, in some applications you may need to select a less than optimum range, or one that is beyond the fringes of the ranges listed in [table 1-1 on page 1-3](#).

1. Changes in Gain and Tracking will be superceded by Autocalibration.

Scan Width

Increasing scan width will increase the number of scans in a picket fence oriented application. Scan width is linked with scan range (as shown in [Step 3, "Estimate Scan Width," on page 1-4](#)) and changing one will usually require a change in the other.

Label Speed

Applies to both picket fence and ladder oriented labels. If your application allows it, label speed (the time in seconds in which a label is fully within the scan width of the scanner) is an effective way to alter the number of scans.

Label Dimensions, Label Density, and Label Ratio

Not usually an option in most applications, but changes to label parameters can affect number of scan calculations and possibly read rates.

If your application allows it, shortening the length of a picket fence label means the label will be in the scan range longer and hence receive a greater number of scans. Increasing the height of a ladder label means it will receive more scans. Changing label density and/or ratio is another way ranges, read rates, etc. can be altered.

Gain, Tracking, Bandwidth, and Clock Speed

These adjustments, typically made by technicians, are done from within the Calibration Setup menu. Of these, Gain and Tracking are already adjusted automatically by Autocalibration, and changes to Bandwidth and Clock Speed will generally have a limited effect on read rates. See [Chapter 4, "Calibration."](#)

11 Install Scanner

The scanner can be mounted directly to a mounting surface of your choice, or indirectly, via a mounting plate.

To permanently mount the scanner:

- Position the scanner in place devoid of sunlight, bright lights, or laser light from other sources.
- Before mounting, ensure that there is clearance at the rear of the scanner for the connectors and cables being used.
- Use the measurements provided in [figure 1-12](#) to locate centers of mounting holes and drill four 0.203 inch or four 6.7 mm holes.

Caution: Penetration depth of screws should not exceed 0.3 inch maximum.

Caution: To prevent twisting or distortion of the scanner housing, ensure that the surface or bracket to which the scanner will be mounted is flat. If necessary, use only three mounting screws instead of four.

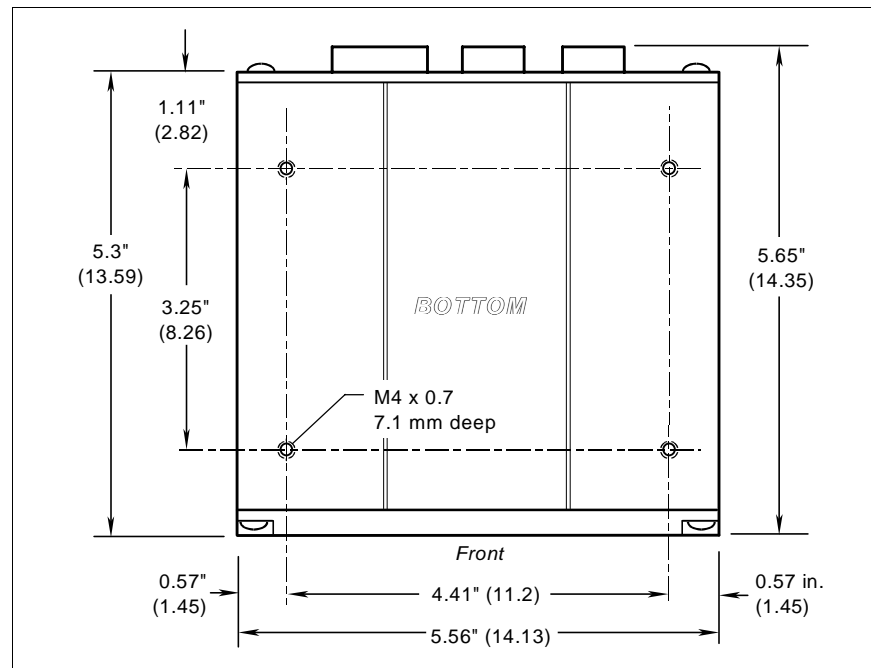

Figure 1-12 Bottom Mounting Holes of MS-7100 (not to scale)

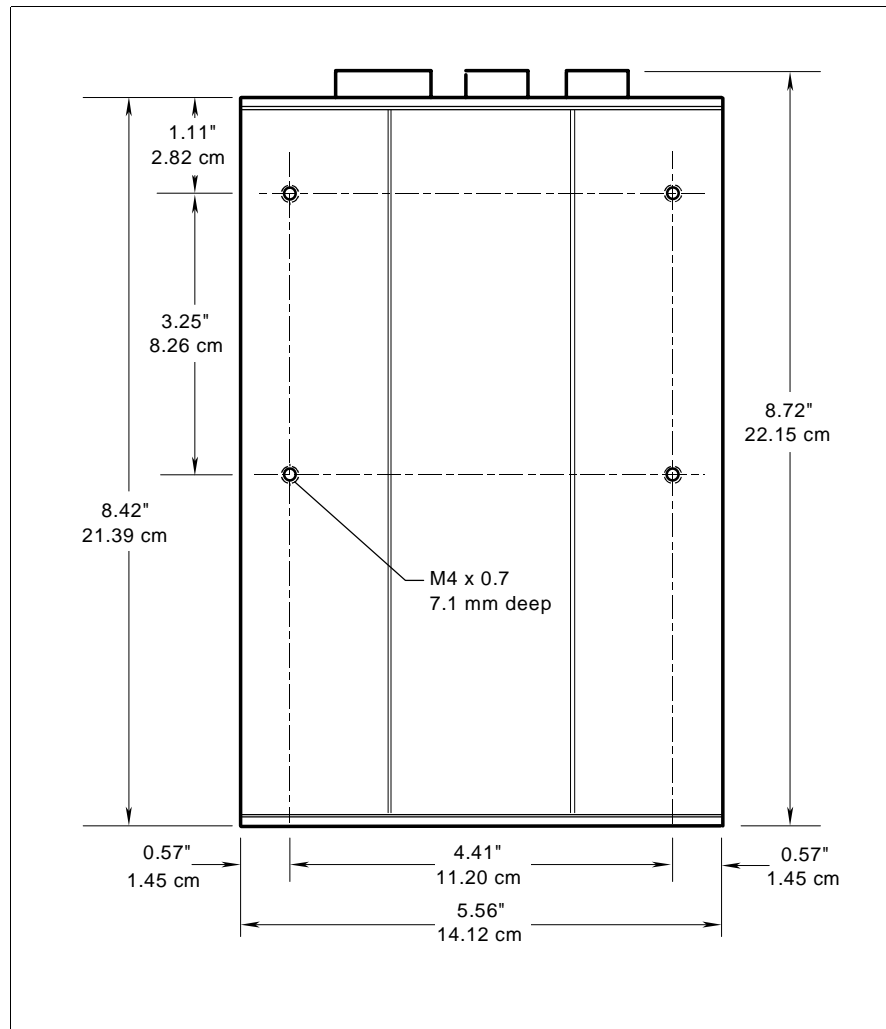

Figure 1-13 Bottom Mounting Holes of MS-7180 (not to scale)

Operational Tips

Do:

- Check inputs (label speed, length, height, etc.) to ensure the desired number of scans per label.
- Avoid excessive tilt, pitch, and skew of the bar code label.
- Check the label for readability by doing a read rate test. If there is any question about the label's readability, contact your Microscan representative.
- After changing any parameter that might affect read rate, repeat read rate test, and if necessary, Autocalibration.
- Clean the laser window with a clean, dry cotton swab on a regular basis.

Do Not:

- Aim the scanner into direct light or sunlight.
- Aim the scanner into a photo detector or other light-emitting device.
- Obstruct the laser window with mounting hardware or other objects.
- Connect chassis of scanners and host to different ground potentials (see [“Ground and Shield Considerations” on page A-9](#)).
- Operate the scanner in excessive temperature environments (see [“Appendix A — Scanner Specifications” on page A-2](#)).

Chapter 2

Menu Configuration

Chapter Contents

| | |
|---|------|
| Entering the Menu Configuration Program | 2-2 |
| Using the Menu Configuration Program | 2-2 |
| Saving Menu Changes | 2-4 |
| Loss of Communications | 2-4 |
| Defining Special Characters | 2-4 |
| Communications Menu | 2-5 |
| Operations Menu | 2-12 |
| Code Types Menu..... | 2-22 |
| User Outputs Menu..... | 2-31 |
| Raster Setup Menu | 2-37 |

This chapter describes how to configure the MS-7100/7180 scanner with on screen menu commands from a host or auxiliary terminal.

All keystrokes are in bold typeface.

Default parameters in the menu structures are also in bold typeface.

All of these parameters, with the exception of Full Screens, can also be changed by serial commands (see [Chapter 3, "Serial Configuration"](#)).

Communicating with an ASCII Terminal

The scanner communicates in full duplex, terminal mode with no hand-shake. It also recognizes carriage returns and line feeds.

The host or ASCII terminal must match the following default settings before any communication can take place: 9600 Baud Rate, Seven Data Bits, Even Parity, and One Stop Bit.

Entering the Menu Configuration Program

To see the Main menu (figure 2-1) from an ASCII terminal that is connected to the scanner, enter the operational command <D> (enter the < > brackets as well as the upper case D).¹

```

MICROSCAN SYSTEMS, INC.
CONFIGURATION PROGRAM
MAIN MENU
35-227012-10
-----
TOPICS                DESCRIPTIONS
1) COMMUNICATIONS    HOST PROTOCOL, HOST PORT, AND AUX PORT.
2) OPERATIONS        TRIGGERING, TIMEOUTS, ETC.
3) CODE TYPES        CODE SELECTIONS, CODE LENGTHS, ETC.
4) USER OUTPUTS     BEEPER, DATA LINE POLARITY, ETC.
5) RASTER SETUP      RASTER TOP ANGLE, BOTTOM ANGLE AND SPEED.
-----
ESC = MAIN MENU OR EXIT  N = NEXT ITEM
M  = PREVIOUS MENU      SP = NEXT ITEM
B  = PREVIOUS ITEM      CR = THIS ITEM
-----
MAIN--> COMMUNICATIONS

```

Figure 2-1 Configuration Program - Main Menu²

Using the Menu Configuration Program

The bottom line on the screen is called the command line. The command line identifies your place in the menu program, shows current status and allows you to review and change options. Use the designated keys³ to scroll to and select the parameter you wish to change; press SP (space bar key) to scroll ahead, B to scroll back, CR (carriage return key) to select, and M to return to the previous higher level menu. To return to the Main menu at any time, press ESC (escape key) and M.

1. Command start character by default is a left angle bracket, <. It may be redefined by menu or serial command. However, the end character, a right angle bracket > cannot be changed.
2. Item 5, Raster Setup, applies only to the MS-7180.
3. The menu navigational keys are displayed in each menu.

For example, to enable LRC (see [figure 2-2 on page 2-5](#) and “[Longitudinal Redundancy Check](#)” on page 2-9) use the following command line path:

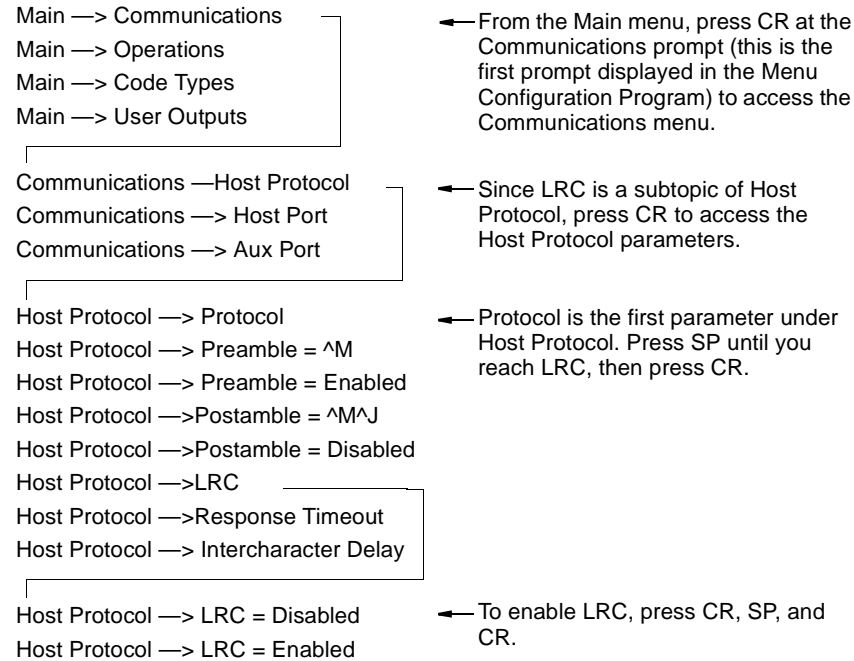

To view LRCs new status in the menu, press M to refresh the screen. To return to the Main menu, press M again. You can make additional changes within another menu before exiting the program. Simply follow the same method of scrolling to and selecting each main topic, then its subtopics, until you reach the parameter you want to change. Remember, to return to the Main menu at any time, press ESC (Escape key) and M.

Some parameters are user defined, in which case they prompt you with an arrow for data, such as:

```
OPERATIONS--> TIMEOUT in 10ms increments      = 100 -->
```

At the prompt, redefine the parameter within the allowable range, and press CR to enable.

Saving Menu Changes

Press ESC (Escape key) to see the following on the command line:

```
EXIT OR MAIN MENU (E,M)
```

Press M to return to the Main menu, or press E to exit the Menu Configuration program. If E is pressed, the following question will appear:

```
Do you want to save changes for power on ? (Y=yes N=no)
```

Press N to exit without saving changes, or press Y to retain the current settings for power up. If Y is selected, a second beep will indicate the save has been carried out.

Note: Choosing Y will save only current changes that were made in the Configuration menus and will not affect Calibration settings.

Loss of Communications

Defaulting might be necessary if communications between the scanner and another device are interrupted or if using incompatible equipment (for example, a terminal is set to communicate at 9600 baud, but the scanner is configured at 38.4K baud). Communication can also be lost if an address has been assigned to the scanner.

To reset parameters to default values, see [Appendix E, "Defaulting the Scanner,"](#) on page A-10.

Defining Special Characters

To define any control character from the ASCII table: Press SP once, then enter the control character by holding down the control key and simultaneously pressing the desired character. For example to define a line feed, press SP, then Control and J simultaneously. It is displayed as ^J on the command line and as <LF> in the menu when the screen is refreshed.

To define CR as a character: Press SP, then CR. It is displayed as ^M on the command line and as <CR> in the menu when the screen is refreshed.

To define a space as a character: Press SP twice. It is displayed as a blank space in the menu when the screen is refreshed. While it appears that nothing has been assigned, the hex value 20 will be sent during data transmission.

To select NUL as the character: Press SP, then a 0 (zero). It is displayed as <NUL> in the menu when the screen is refreshed.

Communications Menu

The Communications menu (see [figure 2-2](#)) allows you to set the communication protocols between the scanner and the host.

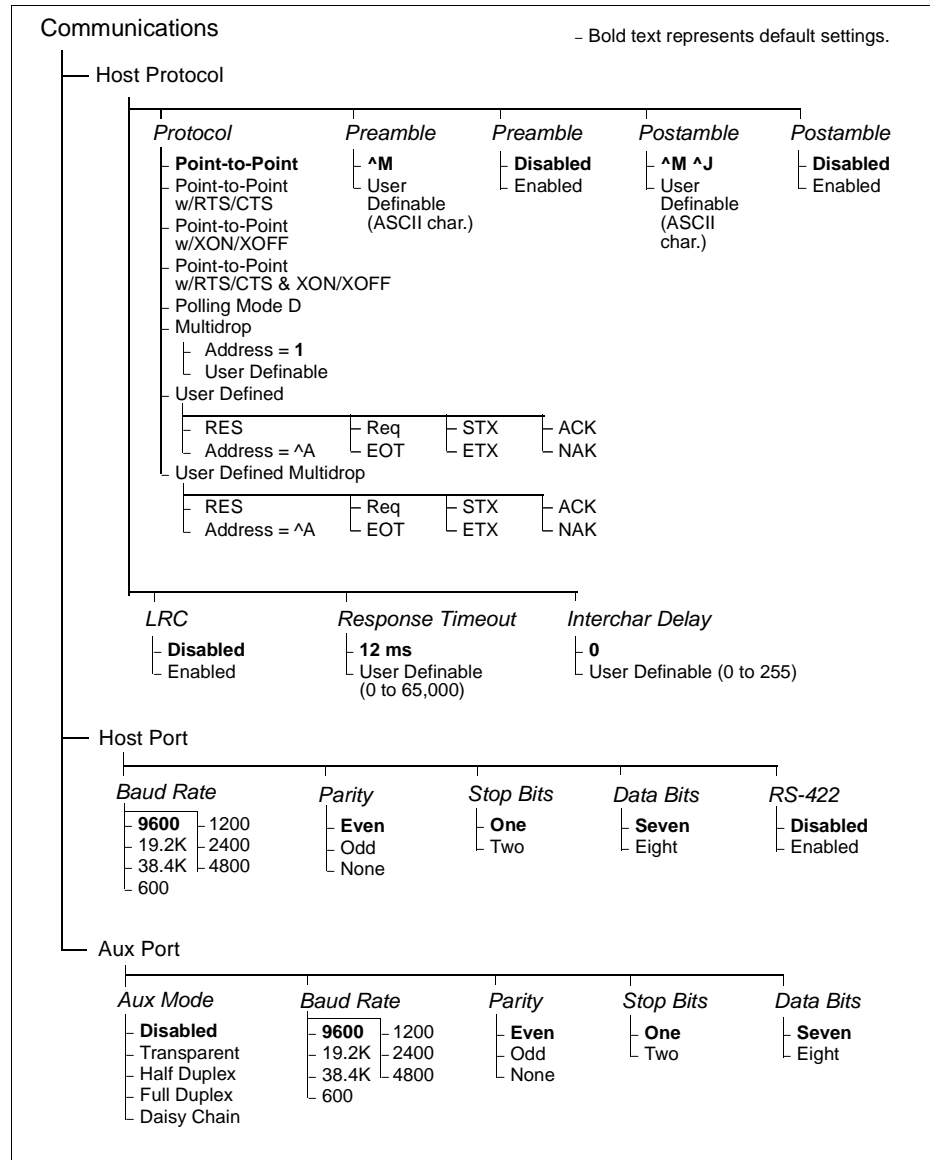

2-Menu Config.

Figure 2-2 Communications Menu Structure

This menu can be regarded as three menus in one: a Host Protocol menu, a Host Port communications menu, and an Aux Port communications menu. To help visualize the menu organizational structure, see [figure 2-2 on page 2-5](#). Note that the parameters (baud rate, parity, etc.) relate to the Host Port and Aux Port.

Note: Changes in Communications parameters or assigning an address to the scanner can cause loss of communications with the configuration terminal when you exit the menu program (whether or not changes are saved for power-on).

Host Protocol Parameters

Protocol

Default: Point-to-Point

Options: Point-to-Point, Point-to-Point with RTS/CTS, Point-to-Point with XON/XOFF, Point-to-Point with RTS/CTS and XON/XOFF, Polling Mode D, Multidrop, User Defined, and User Defined Multidrop.

Protocols define the sequence and format in which information is transferred between devices. Generally there are two basic protocol modes: unpolled and polled. In unpolled mode (all of the Point-to-Point protocols), a device sends information without any request from the host. In polled mode (Multidrop, Polling Mode D, and User Defined Multidrop), a device has an address and waits for a request from the host before sending data.

| <i>Selecting:</i> | <i>Has this effect:</i> |
|---|--|
| Point-to-Point | Has no address and sends data to the host (RS-232) whenever it is available and without any request or handshake from the host. |
| Point-to-Point with RTS/CTS (Request-to-Send/Clear-to-Send) | Used only with RS-232. This is a simple handshaking protocol that allows a device to initiate data transfers to the host with an RTS (request-to-send) transmission. The host, when ready, responds with a CTS (clear-to-send) and the data is transmitted. RTS/CTS signals are transmitted over two dedicated wires (pins 4 and 5) as defined in the RS-232 standard. |
| Point-to-Point with XON/XOFF (Transmitter On/Off) | Used with RS-232 or RS-422. The host can send a single byte transmission command of start (XON) or stop (XOFF). If an XOFF has been received from the host, data will not be sent to the host until the host sends an XON. During the XOFF phase, the host is free to carry on other chores and accept data from other devices. |

| <i>Selecting:</i> | <i>Has this effect:</i> |
|--|---|
| Point-to-Point with RTS/CTS and XON/XOFF | Used only with RS-232. It is a combination of Point-to-Point with RTS/CTS and Point-to-Point with XON/XOFF. |
| Polling Mode D | Like Point-to-Point, Polling Mode D requires a separate connection to the host; but unlike Point-to-Point, it requires an address and must wait for a poll from the host before sending data. When in Polling Mode D, an address of 1 is automatically displayed on the configuration screen. However, during transmission, a 1C hex poll address (FS) and a 1D hex select address (GS) are substituted for the 1. |
| Multidrop ^a <i>Note: Scanners intended to link up to a Microscan MS-5000 multidrop concentrator can only be configured in standard Multidrop protocol.</i> | Similar to Polling Mode D except that a unique poll address and select address are required for each multidrop device, and only one host port connection is needed for up to 50 devices. (For Multidrop poll and select characters, see Table A-3, "Multidrop Address Characters," on page A-24.) Requires a concentrator or controller using RS-485 communications. When Multidrop is selected, the protocol characters for RES, REQ, etc. are assigned automatically. (See Table A-3, "Multidrop Address Characters," on page A-24 for poll and select sequences.) |
| User Defined <i>Note: A specific ASCII character must not be assigned more than once.</i> | Used only with RS-232 or RS-422. ASCII characters can be assigned as an address and as protocol commands (RES, REQ, EOT, STX, ETX, ACK, and NAK). User Defined is necessary when a new protocol must be defined to match a specific host protocol. When User Defined is selected, the displayed protocol commands match those of the previously selected protocol. User Defined is considered to be in a polled mode only if an address has been assigned. The address can be any ASCII character from the ASCII in appendix B, except NUL. ^b |

| <i>Selecting:</i> | <i>Has this effect:</i> |
|---|--|
| User Defined Multidrop | Used when connecting to a concentrator or other device that does not match standard Multidrop protocol. |
| Note: <i>A specific ASCII character must not be assigned more than once.</i> | Any single character (01 hex to 7E hex) in the ASCII table can be assigned as the address character. The character chosen is used as the poll character and the subsequent ASCII character becomes the select character. For example, if a ^A (01 hex) is selected as the address, ^B (02 hex) becomes the select address that the host will use in sending host select commands. (See Table A-3, "Multidrop Address Characters," on page A-24.) |

- a. Once the scanner is configured for Multidrop, a terminal connected to the auxiliary RS-232 pins or a default procedure must be used to access the configuration menus again (although serial commands will continue to function).
- b. For example a simple ACK/NAK protocol can be developed by first selecting Point-to-Point, then User Defined, and then assigning characters to ACK and NAK commands. First scroll to the following command:
HOST PROTOCOL --> PROTOCOL --> USER DEFINED--> ACK = -->
Enter a ^F by holding down the Control key while pressing the F key, and then press CR to see the following:
HOST PROTOCOL --> PROTOCOL --> USER DEFINED --> ACK = ^F
The mnemonics ACK and NAK replace the default NULs in the menu.

Note: *Definitions of commands in User Defined and User Defined Multidrop must be duplicated in host applications to enable poll and select sequences to execute correctly during transmission.*

Typically, parameters in User Defined Multidrop are defined by first enabling Multidrop, then enabling User Defined Multidrop. This pre-loads Multidrop characters into the parameters. You then change individual characters to match the host or other requirements.

Preamble

Default: ^M (and a null). Corresponds to <CR><NUL> (carriage return/null) displayed in the menu.

Options: Any ASCII character, including control characters. Control characters entered in the command line are displayed in the menu as mnemonic characters. (See ["Defining Special Characters" on page 2-4](#) and [Table A-3, "Multidrop Address Characters," on page A-24.](#))

Allows you to define a one or two character data string that can be added to the front of the decoded data. For example, defining a carriage return and line feed would cause each decoded message to be displayed on its own line.

If User Defined, Polling Mode D, or Multidrop is enabled, the Preamble and Postamble characters are transmitted within the STX and ETX data block.

Preamble (enable/disable)

Default: Disabled

Options: Disabled, Enabled (within any protocol)

Allows you to enable or disable the preamble character(s).

Postamble

Default: ^M^J. Corresponds to <CR><LF> (carriage return/line feed) displayed in the menu.

Options: Any ASCII character, including control characters. Control characters entered in the command line are displayed in the menu as mnemonic characters. (See “[Defining Special Characters](#)” on page 2-4 and [Table A-3](#), “[Multidrop Address Characters](#),” on page A-24.)

Allows you to define a one or two character data string that can be added after the decoded message.

If User Defined, Polling Mode D, or Multidrop is enabled, the Preamble and Postamble characters are transmitted within the STX and ETX data block.

Postamble (enable/disable)

Default: Disabled

Options: Disabled, Enabled (within any protocol)

Allows you to enable or disable the Postamble character(s).

Longitudinal Redundancy Check

Default: Disabled in unpolled mode; Enabled in polled mode

Options: Disabled, Enabled

An error-checking routine that verifies the accuracy of transmissions. It is the exclusive OR of all characters following the SOM (start of message) up to and including the EOM (end of message).

Response Timeout

Default: 12 ms.

Options: 0 to 65,000 ms. A zero (0) setting causes an indefinite wait.

Allows you to set the time the scanner will wait before timing out if ACK, NAK, and ETX are enabled, and a host response is expected.

Intercharacter Delay

Default: 0 ms

Options: 0 to 255 ms. A zero (0) setting causes no delay between characters.

Allows you to set the time interval between individual characters transmitted from the scanner to the host. A high setting will significantly slow down communications. For example, a 200 setting will result in a 1/5 second delay between each character that is transmitted.

Host Port Parameters

Allows you to set parameters for host port communications.

Baud Rate

Default: 9600

Options: 600, 1200, 2400, 4800, 9600, 19.2K, 38.4K

Allows you to set the number of bits transmitted per second.

Note: *Due to timing considerations, polled modes require 2400 baud or faster.*

Parity

Default: Even

Options: Even, Odd, None

Allows you to select an error detection routine in which one data bit in each character is set to 1 or 0 so that the total number of 1 bits in the data field is even or odd.

Stop Bits

Default: One

Options: One, Two

Allows you to select the last one or two bits in each character to indicate the end of the character.

Data Bits

Default: Seven

Options: Seven, Eight

Allows you to establish the total number of bits in each character.

RS-422

Default: Disabled

Options: Disabled

Note: Used only in Point-to-Point protocol, and not with RTS/CTS.

Enabled

Whenever RS-422 is disabled, RS-232 is enabled in the background.

However, when Multidrop is enabled, the functioning protocol is RS-485 regardless of the displayed status of RS-422 in the menus. Before enabling RS-422, first double-check that Multidrop is not enabled. (See [“Protocol” on page 2-6](#).

(See [Appendix H, “Interface Standards,” on page A-15](#) for additional information on RS-422.)

Aux Port Parameters

Allows you to set mode and communications parameters between the scanner and an auxiliary monitor. An auxiliary monitor can be used to configure the menus, send data to the host, and display data transmissions originating from the host or scanner.

Note: Aux Port operates in RS-232 only. See [Appendix I, “Auxiliary Monitor,” on page A-16](#) for a full description of auxiliary port options.

Aux Mode

Default: Disabled

Options: Disabled, Transparent, Half Duplex, Full Duplex, Daisy Chain.

Aux Mode (auxiliary mode) allows you to select a communications mode for auxiliary operations (see [Appendix I, “Auxiliary Monitor,” on page A-16](#)).

Other Aux Port Parameters

The other Aux Port parameters—Baud Rate, Parity, Stop Bits, and Data Bits—are identical to the host port parameters and are changed in the same manner.

Note: The Aux Port baud rate should never exceed Host Port baud rate or auxiliary port data could be lost.

Operations Menu

The Operations menu allows you to set the operations parameters for the scanner.

To help visualize the menu's organization and to locate the page number where each topic is described, see [figure 2-3](#).

2-Menu Config.

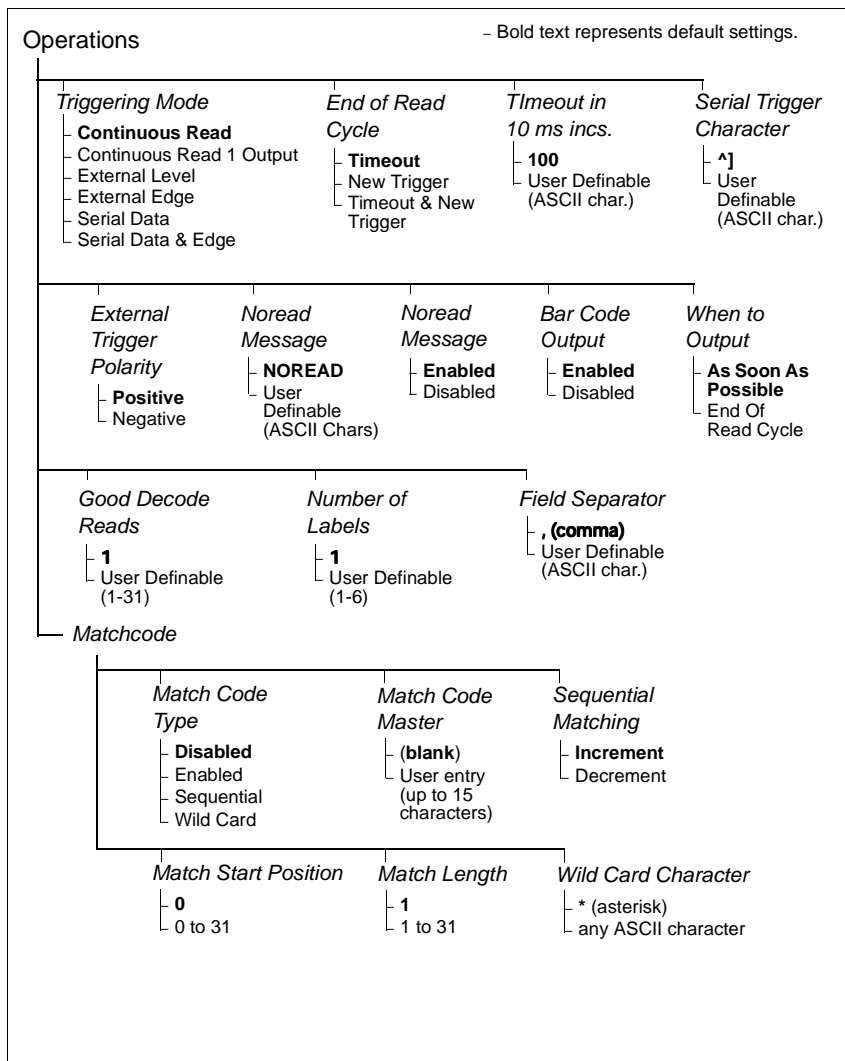

Figure 2-3 Operations Menu Structure

Triggering Mode

Default: Continuous Read

Options: Continuous Read, Continuous Read 1 Output, External Level, External Edge, Serial Data, Serial Data & External Edge

Allows you to establish the type of trigger event that initiates or ends the read cycle. (See [“End of Read Cycle” on page 2-14.](#))

| <i>Selecting:</i> | <i>Has this effect:</i> |
|--|---|
| Continuous Read Note: <i>If Continuous Read is enabled with Match Code, the scanner defaults to Continuous Read 1 Output mode.</i> | Trigger input options are disabled and the scanner is always in the read cycle. Bar code data is decoded, and label information is transmitted repeatedly, as long as the label is in the read range of the scanner. When To Output options have no affect on Continuous Read. Continuous Read is useful in testing label or scanner functions. |
| Continuous Read 1 Output ^a <i>NOTE: Enabling Continuous Read 1 Output when Number of Labels (page page 2-18,) is set to any number greater than one, will cause Number of Labels to default back to one.</i> | Label data is immediately transmitted with Timeout enabled for End Of Read Cycle. If the label doesn't change, the scanner will repeat the output at the end of each subsequent timeout period. For example, if Timeout were set to one second, the scanner would output the label data immediately, and then repeat the output at intervals of one second, for as long as the label continued to be scanned. With Timeout disabled (that is, End Of Read Cycle set to New Trigger), the scanner will output the current label data immediately, but output it only once. A new label appearing at any time in the scan range will produce a new read output as long as the new label is not identical to the previous label. |
| External Level | Allows a read cycle to be initiated by a trigger signal from an object detector when an object appears within the detector's range. The read cycle endures until the object moves out of the detector's range (figure 2-4 on page 2-14) unless a timeout occurs and Timeout is enabled for End of Read Cycle. ^b |
| External Edge | As with Level, Edge allows a read cycle to be initiated by a trigger signal from an object detector when it detects the appearance of an object (rising edge). But unlike Level mode, the removal of an object (falling edge) does not end the read cycle. With Edge enabled, the read cycle ends with a good read output, a timeout, or a new trigger (figure 2-5 on page 2-14). |

| <i>Selecting:</i> | <i>Has this effect:</i> |
|-----------------------------|--|
| Serial Data | The scanner accepts an ASCII character from the host or controlling device as a trigger to start a read cycle. |
| Serial Data & External Edge | The scanner accepts either an external trigger or a serial ASCII command to start a read cycle. |

- a. Continuous Read 1 Output will allow an output regardless of how Good Decode Reads is set.
- b. *Level* and *Edge* apply to the active logic state (positive or negative) that exists while the object is in a read cycle, between the rising edge (the appearance of an object) and falling edge (disappearance of the object).

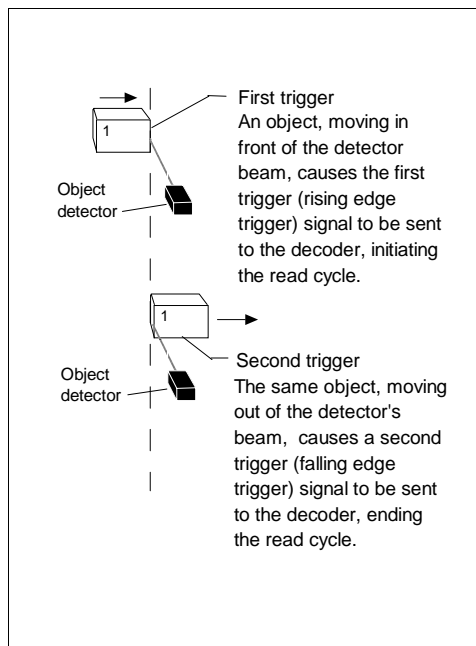

Figure 2-4 External Level Trigger Signals

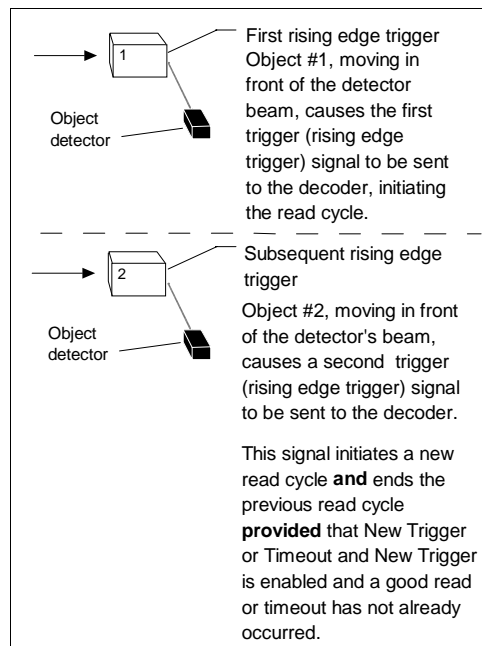

Figure 2-5 External Edge Trigger Signals

End of Read Cycle

Default: Timeout

Options: Timeout, New Trigger, Timeout & New Trigger

Allows you to choose the conditions that will end the read cycle. The read cycle is the time during which the scanner will receive and process label

data. When the Triggering Mode option is set in an External or Serial mode of operation, the trigger event initiates the read cycle.

Note: When operating in Continuous Read or Continuous Read 1 Output, the scanner is always in the read cycle.

| <i>Selecting:</i> | <i>Has this effect:</i> |
|-----------------------|--|
| Timeout | <p>Can end the read cycle after a specified period of time, and if no label has been read, causes a noread message, if enabled, to be transmitted.</p> <p>With either External Edge, Serial Data, or Serial Data & Edge enabled, a timeout ends the read cycle.</p> <p>With External Level enabled, the read cycle does not end until the falling edge trigger occurs, and the next read cycle does not begin until the next rising edge trigger.</p> <p>With Continuous Read 1 Output enabled, a timeout initiates a new read cycle and allows the same label to be read again.</p> |
| New Trigger | <p>Ends the read cycle at the occurrence of a new trigger event, and if no label has been read, causes a noread message, if enabled, to be transmitted at the occurrence of the new trigger event.</p> <p>With either External Edge, Serial Data, or Serial Data & Edge enabled, an edge or serial trigger ends a read cycle and initiates the next read cycle.</p> <p>With External Level enabled, a falling edge trigger ends a read cycle. However, the next read cycle does not begin until the occurrence of the next rising edge trigger.</p> |
| Timeout & New Trigger | <p>Ends the read cycle after a specified period of time or at the occurrence of new trigger event, and if no label has been read, causes a noread message, if enabled, to be transmitted.</p> <p>With either External Edge, Serial Data, or Serial Data & Edge enabled, a timeout, or an edge or serial trigger, whichever comes first, ends the read cycle. An edge or serial trigger also initiates a new read cycle.</p> <p>With External Level enabled, the read cycle does not end until the occurrence of a falling edge, and the next read cycle does not begin until the next rising edge trigger.</p> |

2-Menu Config.

Timeout (in 10 ms incs)

Default: 100 (one second). Corresponds to 1000 ms displayed in the menu.

Options: 0 to 65535. Divide the number entered on the command line by 100 for time in seconds.

Note: Timeout or Timeout & New Trigger under End of Read Cycle ([page 2-14](#),) must be enabled for Timeout (in 10 ms incs) to take effect.

Allows you to define the duration of the timeout period.

Serial Trigger Character

Default: ^]. Corresponds to <GS > displayed in the menu.

Options: A single ASCII character, including control characters, except a NUL (00H), an existing host command character,¹ or an on-line protocol character. Control characters entered on the command line are displayed in the menu as mnemonic characters. See “Defining Special Characters” on [page 2-4](#) and [Table A-1, “ASCII Table with Control Characters,”](#) on [page A-5](#).

Note: Serial Data ([page 2-14](#)) or Serial Data & Edge ([page 2-14](#)) must be enabled for Serial Trigger Character to take effect. “N/A” is displayed in the menu when all other triggering modes are enabled.

Allows you to define a single ASCII character as the host serial trigger character that initiates the read cycle. The serial trigger is considered an on-line host command and requires the same command format as all host commands (that is, to be entered within the < > brackets).

External Trigger Polarity

Default: Positive

Options: Positive, Negative

Note: External Level ([page 2-13](#)) External Edge ([page 2-13](#)) or Serial Data & Edge ([page 2-14](#)) must be enabled for External Trigger Polarity to take effect. “N/A” is displayed in the menu when all other triggering modes are enabled.

Allows you to determine whether a positive or negative transition will initiate the read cycle.

Note: If using the Microscan object detector (P/N 99-440001-03), use positive trigger polarity.

1. For example, assigning an upper case D would nullify the <D> (Enter Menu Configuration) command. For a list of operational commands used by the scanner, see [table 5-1 on page 5-2](#).

Noread Message

Default: NOREAD

Options: Up to seven ASCII characters

Allows you to define any combination of ASCII characters (except a NUL) up to seven characters as the noread message.

The noread message, if enabled and if no bar code label has been decoded, will be transmitted to the host at a timeout or the end of a read cycle.

Noread Message (enable/disable)

Default: Enabled

Options: Enabled, Disabled

Note: If Noread Output is enabled, the noread message will only output if Bar Code Output ([page 2-17](#)) is also enabled.

Allows you to enable or disable the noread message.

Bar Code Output

Default: Enabled

Options: Enabled, Disabled

Allows you to choose whether or not to output label data or a noread to the host. When disabled, a label is decoded and the read cycle transpires as usual, but neither label data nor the noread message is transmitted to the host. Scanner counters are updated, and the current number of good reads or noreads can be obtained via operational commands.

When to Output

Default: As Soon As Possible

Options: As Soon As Possible, End of Read Cycle

Allows you to choose when bar code data is sent to the host.

| <i>Selecting:</i> | <i>Has this effect:</i> |
|---------------------|---|
| As Soon As Possible | Causes bar code data (good reads) to be transmitted immediately upon a good decode. |
| End of Read Cycle | Causes bar code data output to be delayed until the end of the read cycle. |

Good Decode Reads

Default: 1

Options: 1 to 31

Allows you to select the number of good reads (from 1 to 31) required per label before a good decode output.

Note: Be sure that the value set is within the determined scan rate for the scanning setup so that the scanner is capable of scanning a label the required number of times.

Number of Labels

Default: 1

Options: 1 to 6

Note: If Number of Labels is set to any number greater than one while Match Code or Continuous Read 1 Output is enabled, Number of Labels will default back to one.

Allows you to choose the number of different labels that the scanner will read during a single trigger event. The labels can be a mix of any enabled bar code symbologies and more than one label can be decoded per scan line.

The following conditions apply:

1. Each label must be different to be read.
2. The maximum number of characters in any one label is 51, unless Fixed Code Length is enabled in which case the maximum length is 31.
3. The maximum number of characters in a single scan line is 102.
4. The maximum number of characters for all labels scanned is 255, including preamble, postamble, and all spaces and commas.
5. All noread messages are posted at the end of the data string.
6. If more than one label is within the scan beam at the same time, label data may not be displayed in the order of appearance.

Field Separator

Default: , (comma)

Options: Any available ASCII character, except NUL.

Allows you to choose the separator character to be inserted between labels.

Match Code

Default: Disabled

Options: Disabled, Match Code Type, Match Code Master, Sequential Matching, Match Start Position, Match Length, Wild Card Character

Note: A triggered mode (see [“Triggering Mode” on page 2-13](#)) must be enabled for Match Code to take effect.

Note: If Match Code is enabled with Continuous Read, the scanner defaults to Continuous Read 1 Output mode, and the label data must change before the scanner will output data again, unless a timeout, if enabled, occurs.

Note: Enabling Match Code when Number of Labels is set to any number greater than one, will cause Number of Labels to default back to one.

Allows you to enter a master label into the scanner's memory to be compared with subsequently scanned labels.

With Match Code enabled, a master label can be entered in three ways:

1. With New Master Pin enabled ([page 2-34](#)), toggling pin 27 to ground (pin 7) enables the next good read to be the master label.
2. Sending serial command <G> enables the next good read to be the master label.
3. Sending serial command <)XXXX)> downloads data as master label.

[“Master Label Entry” on page 2-21](#) shows the sequence of operation (and reference) for setting up and entering master labels. See also [“New Master Pin” on page 2-34](#).

Match Code Type

Default: Disabled

Options: Disabled, Enabled, Wild Card, and Sequential

When not disabled, allows you to enter a master label into the scanner's RAM to be compared with subsequently scanned labels. The results of this comparison determine the scanner's data and relay outputs, if enabled.

The following conditions apply:

1. A triggered mode must be enabled for Match Code Type to take effect.
2. Not disabling Match Code Type when Number of Labels is set to any number greater than one will cause Number of Labels to default back to one.
3. If you wish to send a pulse on a Good Read, Match Code Type must be disabled.

Disabled

Disabled has no effect on operations.

Enabled

Instructs the scanner to compare labels or portions of labels with the master label.

Sequential

Instructs the scanner to compare labels or portions of labels for sequential numbers in ascending or descending order.

There are four ways to load a master (see [“Master Label Entry” on page 2-21](#)). In every case sequencing occurs after each match. See [“Match Code” on page 3-10](#) for special noread and mismatch sequences.

Wild Card

Allows you to enter user defined wild card characters in the master label.

For example, with wild card defined as the default asterisk, entering URGENT** as your master label will result in matches for URGENT, URGENT1, and URGENT12 but not for URGENT123.

As in the above example, when wild cards are appended to the end of the master label, labels of variable lengths can result in matches. However, wild cards in the beginning or center of a label (e.g., UR**NT) do not allow for variable label lengths.

Match Code Master

Default: (blank)

Options: Displays current master and accepts user entry up to 31 characters.

Allows you to edit an existing master or type in a new master label from your keyboard.

Sequential Matching

Default: Increment

Options: Increment, Decrement

Defines the order (ascending or descending) in which labels will be compared when Match Code Type is set to Sequential.

Match Start Position

Default: 0

Options: 0 to 31

Match Start Position must be set to 1 or greater to enable this feature.

Defines the first character in the label (from left to right) that will be compared with those of the master label when Match Code Type is set to Enabled or Sequential. For example, if you set Match Start Position to 3, the first 2 characters read in the label will be ignored and only the 3rd and subsequent characters to the right will be compared, up to the number of characters specified by Match Length.

Match Length

Default: 1

Options: 1 to 31

Defines the length of the character string that will be compared with that of the master label when Match Code Type is set to Enabled or Sequential and Match Start position is set to 1 or greater. For example, If Match Length is set to 6 in a 10 character label, and Match Start Position is set for 2, only the 2nd through 7th characters (from left to right) will be compared.

Wild Card Character

Default: * (asterisk)

Options: Any ASCII character

Allows you to define the wild card character that can be used when defining a master label.

Master Label Entry

With Match Code Type set to Enabled, Sequential, or Wild Card, a master label can be entered in four ways:

1. By typing in from the keyboard at the command line of the Operations menu under Match Code Master.
2. With New Master Pin enabled (see [page 2-34](#)), toggling scanner pin 12 to ground (or by momentarily pressing the New Master button on the IB-105) will save the next label read as the master label.
3. Sending serial command <G> allows the next label read to be the master label.
4. Sending a serial command in the format <)XXXX)> downloads data as the master label.

Code Types Menu

The Code Types menu allows you to choose among five bar code types and define their parameters, as shown in [figure 2-6](#)¹.

2-Menu Config.

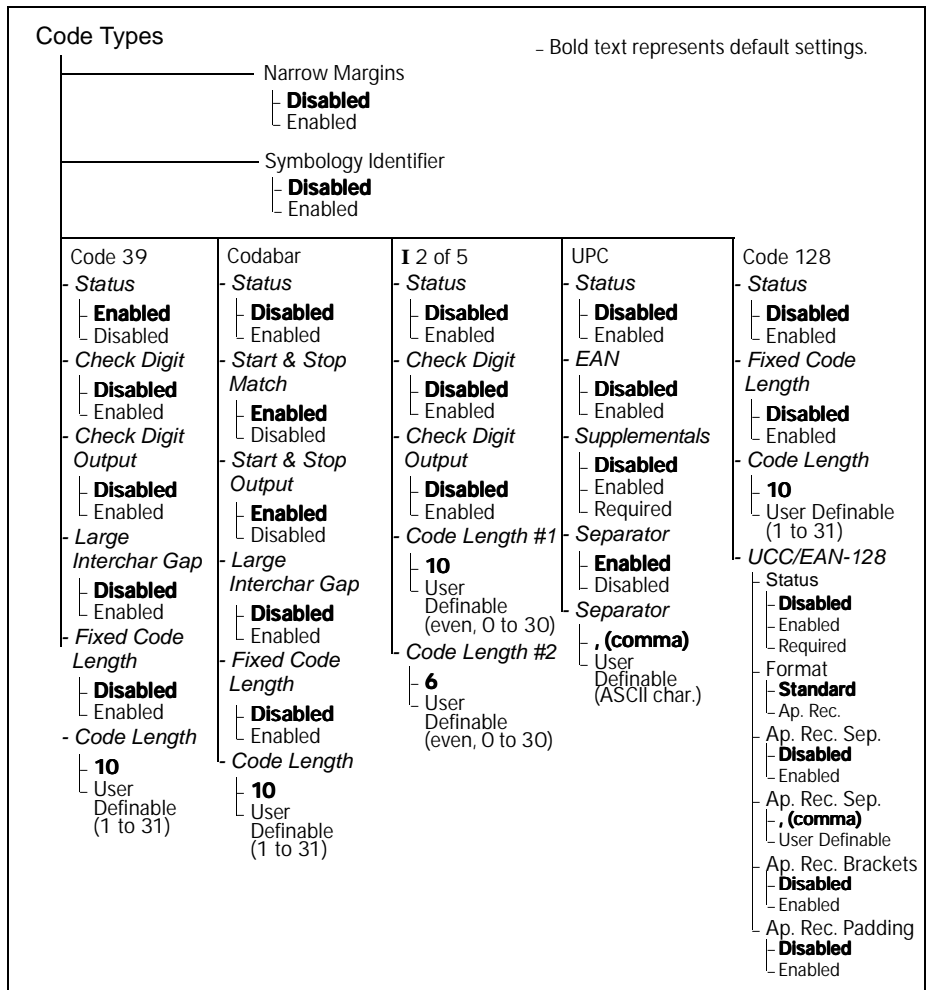

Figure 2-6 Code Types Menu Structure

Options can be defined for any bar code type whether or not the bar code itself is enabled at the time.

1. Options listed in the command line appear in a different order than those posted in the first column of the Code Types menu

Narrow Margins

Default: Disabled

Options: Disabled, Enabled

Allows the scanner to read bar codes with quiet zones less than 10 times the narrow-bar-width. Quiet zone is a term used to describe the minimum space at the leading and trailing ends of a label. Each quiet zone can be as small as five times the narrow bar element when Narrow Margins is enabled.

Symbology ID

Default: Disabled

Options: Disabled, Enabled

When enabled, the scanner reads and outputs a three character prefix:

1. **]** (close bracket character) indicating the presence of a symbology ID
2. **A, F, I, E, or C**
A = Code 39; F = Codabar; I = I 2 of 5; E = UPC/EAN; C = Code 128
3. A single number indicating the status of the check digit character (table 2-1):
If check digit is not enabled, the output is 0 (col. 1). If check digit and check digit output are enabled, the output is as shown in column 2. If check digit is enabled, but output is disabled (col. 3), the output is as shown in col. 4, which is the sum of col. 2 and col. 3.

Table 2-1 Symbology Identifier Option Values

| | Column 1 No check character | Column 2 Check digit and output enabled | Column 3 Check digit output disabled | Column 4 Sum of Col- umn 2 and 3 |
|----------|--------------------------------------|---|--|--|
| Code 39 | 0 | 1 | (2) | 3 |
| Codabar | 0 | 2 | (4) | 6 |
| I 2 of 5 | 0 | 1 | (2) | 3 |
| UPC/EAN | Always zero, do not follow AIM spec. | | | |
| Code 128 | | | | |

Example 1: For Code 39, if check digit and check digit output are both enabled, a 1 will be output; but if check digit output is disabled, a 3 (the sum of column 2 and column 3) will be output.

Example 2: For Codabar, if check digit and check digit output are both enabled, a 2 will be output; but if check digit output is disabled, a 6 (the sum of 2 and 4) will be output.

Code 39

Status

Default: Enabled

Options: Enabled, Disabled

Check Digit

Default: Disabled

Options: Disabled, Enabled

Code 39 is self-checking and does not normally require a check digit. However, for additional data integrity, a Modulus 43 check digit can be added to the bar code message. With Check Digit and an External or Serial trigger option enabled (see [“Triggering Mode” on page 2-13](#)) an invalid check digit calculation will cause a noread message to be transmitted at the end of the read cycle.

Check Digit Output

Default: Disabled

Options: Disabled, Enabled

When enabled, the check digit character is sent along with the label data. When disabled, label data is sent without the check digit.

Large Intercharacter Gap

Default: Disabled

Options: Disabled, Enabled

Allows the scanner to read labels with gaps between bar code characters exceeding three times the narrow element width.

Fixed Code Length

Default: Disabled

Options: Disabled, Enabled

Used to increase data integrity by ensuring that only label length will be accepted.

Code Length

Default: 10

Options: 1 to 31

Note: Fixed Code Length ([page 2-24](#)) must be enabled for Code Length to take effect.

Allows you to specify the exact number of characters that the scanner will recognize. Any code not having the prescribed length will be ignored by the scanner. Available only when Fixed Code Length is enabled.

Codabar

Status

Default: Disabled

Options: Disabled, Enabled

Start & Stop Match

Default: Enabled

Options: Enabled, Disabled

Requires the Codabar start and stop characters (a, b, c, or d) to match before a valid read can occur.

Start & Stop Output

Default: Enabled

Options: Enabled, Disabled

Allows the start and stop characters to be transmitted with bar code data.

Large Intercharacter Gap

Default: Disabled

Options: Disabled, Enabled

Allows the scanner to read labels with gaps between bar code characters exceeding three times the narrow element width.

Fixed Code Length

Default: Disabled

Options: Disabled, Enabled

Used to increase data integrity by ensuring that only label length will be accepted.

Code Length

Default: 10

Options: 1 to 31

Allows you to specify the exact number of characters that the scanner will recognize. Any code not having the prescribed length will be ignored by the scanner. Available only when Fixed Code Length is enabled.

Interleaved 2 of 5

Status

Default: Disabled

Options: Disabled, Enabled

Because I 2 of 5 is a continuous code, it is prone to substitution errors. Hence, a code length must be defined and a bar code label containing an even number of digits must be used. It is also recommended that a Modulus 10 check digit be used to ensure the best possible data integrity.

Check Digit

Default: Disabled

Options: Disabled, Enabled

I 2 of 5 uses a Modulus 10 check digit.

Check Digit Output

Default: Disabled

Options: Disabled, Enabled

When enabled, the check digit character is sent along with the label data. When disabled, label data is sent without the check digit.

Code Length #1

Default: 10

Options: 0 to 30, even (If you enter an odd number the scanner will use the next lower number.)

With I 2 of 5, two code lengths can be defined. When using only one label length in an application, we recommend setting Code Length #2 to 0 to ensure data integrity. If a check digit is used, it must be included in the code length count.

Code Length #2

Default: 6

Options: 0 to 30, even. (If you enter an odd number the scanner will use the next lower number.)

If using a second label, you may also specify a zero or any even code length from 2 to 30. If not using a second label, set Code Length #2 to 0 to ensure data integrity.

UPC

Status

Default: Disabled

Options: Disabled, Enabled

When enabled, the scanner will read UPC version A and UPC version E only.

EAN

Default: Disabled

Options: Disabled, Enabled

Note: *UPC must also be enabled for EAN to take effect.*

When EAN is enabled, the scanner will read UPC version A, UPC version E, EAN 13, and EAN 8. It will also append a leading zero to UPC version A label information and transmit 13 digits. If you do not want to transmit 13 digits when reading UPC version A labels, disable EAN.

Supplementals

Default: Disabled

Options: Disabled, Enabled, Required

Note: *Narrow Margins must be enabled if the gap between the standard code and the supplemental code is between 5:1 and 10:1 (in relation to narrow-bar-width).*

Allows the scanner to read supplemental bar code data that has been appended to the standard UPC or EAN codes. When in Required mode, supplemental and bar code label data are treated as a single label, and supplemental data must be found or a noread will result.

When set to Enabled, the scanner treats the supplemental data and the bar code label as separate labels.

Separator

Default: Enabled

Options: Enabled, Disabled

Allows you to insert a character between the standard UPC or EAN code and the supplemental code.

Separator (character)

Default: , (comma)

Options: Any ASCII character

Allows you to change the separator character from a comma to a new value.

Code 128

Status

Default: Disabled

Options: Disabled, Enabled

Fixed Code Length

Default: Disabled

Options: Disabled, Enabled

Allows you to increase data integrity by ensuring that only one label length will be accepted.

Code Length

Default: 10

Options: 1 to 31

Allows you to specify the exact number of characters that the scanner recognizes. The scanner ignores any label not having the specified length.

UCC/EAN-128

Status

Default: Disabled

Options: Disabled, Enabled, Required

A subset of Code 128, with extended features.

Note: Code 128 must be Enabled for UCC/EAN-128 to function.

With Enabled selected, both Code 128 and UCC/EAN-128 labels are decoded.

With Required selected, only UCC/EAN-128 labels are decoded.

Format

Default: Standard

Options: Standard, Ap. Rec. (Application Record)

Allows you to choose between Standard UCC/EAN-128 and Application Record formats.

With Standard enabled, UCC/EAN-128 labels are interpreted and output in standard UCC/EAN-128 format.

Application Record is a user-definable variation of UCC/EAN-128 that does the following:¹

- Separates Application Identifier fields.

- Pads variable length fields (unless disabled) with 0's until the maximum length is reached (except for the last field of the label).
- Passes each Application Identifier and its data field onto the application processing software.
- Allows you to add and define separators between data fields, enclose Application Identifier's in brackets, and disable padding.

Note: If an illegal Application Record format is detected, then the scanner will process it as a "noread" message, except that it will output it as a "Bad Format" in place of the noread.

Application Record Separator

Default: Disabled

Options: Disabled, Enabled

Note: Application Record must be enabled under Format before this parameter can take effect.

When enabled, a separator character is inserted between data fields.

Application Record Separator

Default: , (comma)

Options: User Defined

Note: Application Record must be enabled under Format before this parameter can take effect.

Allows you to define an ASCII character as a separator.

Application Record Brackets

Default: Disabled

Options: Disabled, Enabled

Note: Application Record must be enabled under Format before this parameter can take effect.

When enabled, brackets () are added to enclose application identifiers.

1. When Number of Labels ([page 2-18](#).) is set to greater than One, Application Record Padding must be disabled. If Application Record Padding is enabled, label data will be output in the Standard Format.

Application Record Padding

Default: Enabled

Options: Enabled, Disabled

Note: Application Record must be enabled under Format before this parameter can take effect.

Note: When Number of Labels ([page 2-18](#)), is set for more than One, Application Record Padding must be disabled. If Application Record Padding is enabled, output will automatically default to Standard Format.

Padding is the insertion of zeros to make up the maximum length of a variable application identifier field, except for the last field which does not require padding.

When enabled, padding is included.

When disabled, padding is omitted.

Note: Padding is never added to fixed length fields or to the last data field of a label. Enabling or disabling padding will have no effect on these.

User Outputs Menu

The User Outputs menu allows you to configure the scanner's output. To help visualize the menu's organization and to locate the page number where each topic is described, see [figure 2-7](#).

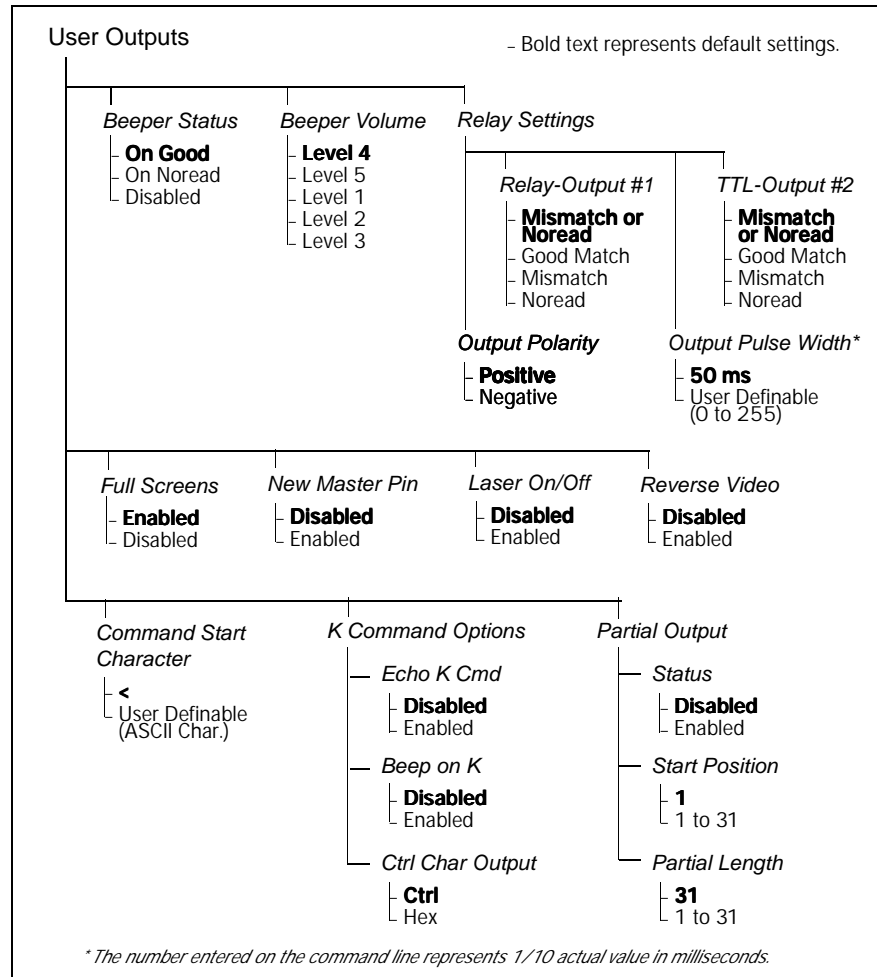

2-Menu Config.

Figure 2-7 User Outputs Menu Structure

Beeper Status

Default: On Good

Options: On Good, On Noread, Disabled

On Good is enabled by default. The options are On Good, On Noread, or Disabled.

Note: The beeper interrupts operations for approximately 100 ms. We recommend that you disable the beeper in high-speed Multidrop operations since the time delay can cause labels to be missed.

Beeper Volume

Default: Level 4

Options: Level 4, Level 5, Level 1, Level 2, Level 3

Relay Settings

Relay--Output #1

Default: Mismatch or Noread

Options: Mismatch or Noread, Good Match, Mismatch, Noread

Allows you to determine the conditions under which internal relay contacts (pins 7 and 9 of the trigger and power connector) will be opened or closed. The TTL level output that drives this internal relay is also available on pin 6 of the host connector and pin 8 of both the trigger and power connectors.¹

| <i>Selecting:</i> | <i>Has this effect:</i> |
|--------------------|--|
| Mismatch or Noread | Sends a pulse when the label's data does not match that of the master label, or the label is not decoded before the end of the read cycle. |
| Good Match | Sends a pulse when the decoded label matches the master label (or any good read if match code is disabled). |
| Mismatch | Sends a pulse when the label's data does not match that of the master label. |
| Noread | Sends a pulse when the label's data is not decoded before the end of the read cycle. |

Note: If Good Match is enabled but Match Code is not enabled (see [“Match Code” on page 2-19](#)) then any occurrence of a good read will cause a pulse to be output and mismatches will be ignored.

1. Pins 6 and 8 can source or sink 4 mA maximum. Pins 7 and 9 can conduct up to 200 mA or 4VA.

TTL--Output #2

Default: Mismatch or Noread

Options: Mismatch or Noread, Good Match, Mismatch, Noread

Allows you to determine the conditions under which a user-programmable TTL pulse will be output (high or low depending on polarity) to pin 25 of the host connector.

| <i>Selecting:</i> | <i>Has this effect:</i> |
|--------------------|--|
| Mismatch or Noread | Sends a pulse when the label's data does not match that of the master label, or the label is not decoded before the end of the read cycle. |
| Good Match | Sends a pulse when the decoded label matches the master label (or any good read if match code is disabled). |
| Mismatch | Sends a pulse when the label's data does not match that of the master label. |
| Noread | Sends a pulse when the label's data is not decoded before the end of the read cycle. |

Note: If Good Match is enabled but Match Code is not enabled (see [“Match Code” on page 2-19](#)) then any occurrence of a good read will cause a pulse to be output and mismatches will be ignored.

Output Polarity

Default: Positive

Options: Positive, Negative

Allows you to choose between positive and negative logic signals to pins 6, 8, and 25 on the host connector, to pin 8 on both the trigger and power connectors, and to the internal relay contacts that open or close a switch between pins 7 and 9 on both the trigger and power connectors.

When Output Polarity is set to Positive, the switch between pins 7 and 9 on the power and trigger connectors will be normally open (unless closed by an output pulse). Conversely, if Output Polarity is set to Negative, pins 7 and 9 of the power and trigger connectors will be normally closed.

Output Pulse Width

Default: 5 (.05 seconds). Corresponds to 50 ms displayed in the menu.

Options: 0 to 255 (0 to 2.55 seconds). Divide the number entered on the command line by 100 for time in seconds.

Allows you to set the duration of the output pulses to pins 6, 8, and 25 on the 28-pin connector, to pin 8 on both the trigger and power connectors,

and to internal relay contacts that open or close a switch between pins 7 and 9 on both the trigger and power connectors.

Caution: Too long of a pulse width can cause missed labels, especially if Output Pulse Width exceeds End of Read Cycle Timeout (see [page 2-14](#)).

Full Screens

Default: Enabled

Options: Enabled, Disabled

Allows you to display either the full menu screen or just the command line. When Full Screens is disabled, only the command line will be displayed.

New Master Pin

Default: Disabled

Options: Disabled, Enabled

Note: Match Code ([page 2-19](#)), and a triggered mode ([page 2-13](#)), must be enabled for New Master Pin to take effect.

Allows you to momentarily connect pin 27 to ground (pin 7) in order to clear any existing master label information from memory and to record the next good read as the new master label information.

Laser On/Off

Default: Disabled

Options: Disabled, Enabled

Note: A serial or external trigger (see [“Triggering Mode” on page 2-13](#)) must be enabled for Laser On/Off to take effect.

When enabled, the laser is ON only during the read cycle. When disabled, the laser operates continuously.

Note: Laser On/Off does not relate to the <H> (Enable Laser Scanning) and <I> (Disable Laser Scanning) operational commands discussed under [“Device Control Commands” on page 5-3](#).

Reverse Video

Default: Disabled

Options: Disabled, Enabled

When enabled, the scanner will read bar code labels with bars that are lighter in color than their corresponding backgrounds.

Command Start Character

Default: <

Options: Any ASCII character (except a NUL).

Allows you to define a new ASCII start character in a serial command.

K Command Options

Echo K Command

Default: Disabled

Options: Disabled, Enabled

When enabled, serial configuration commands (“K” commands) will be processed and the new string for that command will be echoed back to the host. If an invalid command is sent to the host, the scanner will echo back the current setting of that command. For example, if the current Noread Message is “NOREAD” and <Kk1,NONSENSE> is entered, the scanner will echo back: <Kk1,NOREAD>. In this example the attempted entry “NONSENSE” exceeds the maximum allowable seven characters. Therefore it is rejected and the current NOREAD message is echoed back and remains the Noread Message.

Note: It is important to note that if a command with multiple fields is processed, some of the fields may have been processed properly following an “invalid” command. These changes will be in the string echoed back so that the user will know what did or did not change.

Beep on K Command

Default: Disabled

Options: Disabled, Enabled

When enabled, the scanner beeps once whenever a K command is entered to indicate that the command was accepted and processed. If an invalid command is entered, the scanner beeps 5 times to indicate an invalid entry. However, this does not necessarily mean that all data fields have been entered incorrectly. Only one bad field needs to be found in order to activate the 5 beep response.

Control Character Output

Default: Ctrl

Options: Ctrl, Hex

Determines response to an Echo K or status request command. When set to CTRL, ASCII control character output includes a control character as shown in the “Ctrl” column of [Table A-B, “ASCII Table,” on page A-5](#). When set to Hex, the output is the actual character.

Partial Output

Status

Default: Disabled

Options: Disabled, Enabled

When enabled, allows you to pre-select portions of labels to be transmitted by the scanner.

In multilabel mode, partial output is performed on each separate label. For example, if Start Position is set to 3 and Partial Length is set to 5, the following labels are transmitted as follows:

| | | |
|------------|----|--------------------------------------|
| 1234567890 | as | "34567" |
| 1234 | as | "34" |
| 1234,abcde | as | "34,cde" (two labels with separator) |
| 12 | as | "" |

Start Position

Default: 1

Options: 1 to 63

Allows you to determine the first character from the beginning of a label to transmit.

Partial Length

Default: 63

Options: 1 to 63

Allows you to determine the number of characters to be transmitted.

Raster Setup Menu

The Raster Setup menu allows you to set the top and bottom of the raster arc in degrees, control the number of raster sweeps per second, and enable Raster On/Off. [Figure 2-8](#) shows the structure of this menu.

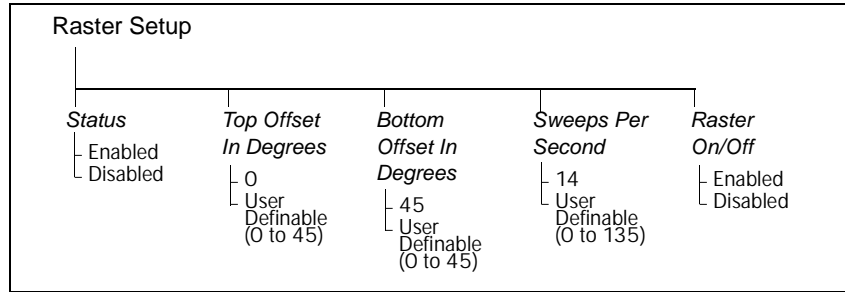

Figure 2-8 Raster Setup Menu Structure

For additional information on raster setup, see Step 4, “[Determine Raster Height and Arc,](#)” on page 1-5 and Step 5, “[Calculate Number of Scans,](#)” on page 1-6.

Status

Default: Enabled
Options: Enabled, Disabled

Top Offset in Degrees

Default: 0 (degrees)
Options: 0 to 45 (in one-degree increments)

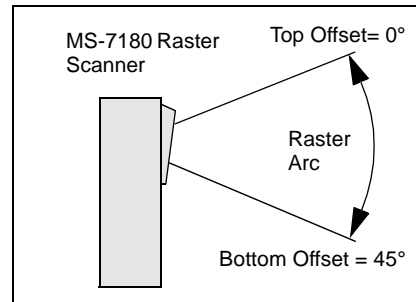

Figure 2-9 Raster Sweep Arc

Table 2-2 Raster Settings

| Raster Arc | Sweeps per Second | |
|------------|-------------------|---------|
| | Minimum | Maximum |
| 1° | 1 | 135 |
| 5° | 1 | 75 |
| 10° | 1 | 45 |
| 15° | 1 | 35 |
| 20° | 1 | 29 |
| 25° | 1 | 23 |
| 30° | 1 | 21 |
| 35° | 1 | 19 |
| 40° | 1 | 17 |
| 45° | 1 | 14 |

2-Menu Config.

Note: Top Offset must always be less than the bottom offset or the resulting arc will be 0°.

Bottom Offset in Degrees

Default: 0 (degrees)

Options: 0 to 45 (in one-degree increments)

Sweeps Per Second

Default: 14 (sweeps per second)

Options: 0 to 135

Allows you to control the raster motor speed. A “sweep” is defined as a single pass, up or down, creating the raster image.

[Table 2-2, “Raster Settings,” on page 2-37](#) shows minimum and maximum possible sweep speeds at selected raster arcs. The minimum speed at any arc is always one sweep per second (SPS). Note that the maximum sweep speed for the raster arc that you have chosen will not exceed the default, even if you enter a higher speed.

To maximize the number of scans a label will receive, it is recommended that as few as possible sweeps per second be selected. However, to ensure that the minimum required scan lines cross the bar code label, it is essential that at least **two full sweeps** occur during the time it takes for the label to pass through the readable scan width area.

For example, if the label is readable in the read range for only 1/10th of a second, then the number of sweeps per second should be at least 20. If readable for only 1 second, then sweeps per second should be at least 2. (To see a formula for calculating sweeps per second, see [Step 5, “Calculate Number of Scans,” on page 1-6.](#))

Raster On/Off

Default: Disabled

Options: Disabled, Enabled

Note: Laser On/Off must be enabled (KC1) for Raster On/Off to take effect.

When enabled, the raster will shut off (or turn on) approximately 1.9 ms after a change in the state of the laser. Since this time delay may interfere with certain applications—for example where a trigger has occurred and a read is expected—you can disable Raster On/Off and the raster motor will remain on at all times.

Chapter 3

Serial Configuration

Chapter Contents

| | |
|---|------|
| Summary of Serial Configuration Commands..... | 3-2 |
| Communications Commands..... | 3-5 |
| Operations Commands..... | 3-9 |
| Code Type Commands..... | 3-12 |
| User Outputs Commands..... | 3-15 |
| Raster Setup Commands..... | 3-17 |

This chapter describes how to configure the MS-7100/7180 scanner by serial commands from a host.¹

All of the configuration parameters that can be changed in the menus with the exception of Full Screens, as described in [Chapter 2, “Menu Configuration,”](#) can also be changed by serial configuration commands.

All of the serial configuration parameters, with the exception of Trigger Filter Timing Value, also appear in the menus.

1. The scanner communicates in full duplex, terminal mode with no handshake. It also recognizes carriage returns and line feeds. The host or ASCII terminal with must match the following default settings before any communication can take place: **9600** Baud Rate, **Seven** Data Bits, **Even** Parity, and **One** Stop Bit. If communicating from an auxiliary terminal via the auxiliary port (pins 18 and 19 of the 28 pin connector, the serial command <D> (Enter Menu Configuration Program) is the only command that the scanner will recognize.

Summary of Serial Configuration Commands

Table 3-1 Summary of Serial Configuration Commands

| Function | Cmd | Command Title | Format |
|---------------------|------|---------------------------------|---|
| (Not in menu) | KF | Trigger Filter Timing Value | <KF?> (returns current value in milliseconds) <KFtime in 10 ms increments> |
| Communi- cations | Kf | Host Protocol | <Kfprotocol,data,...> |
| | Kd | Preamble | <Kdstatus,ASCII characters> |
| | Ke | Postamble | <Kestatus,ASCII characters> |
| | Kc | LRC | <Kcstatus> |
| | KA | Host Response Timeout | <KANumber> |
| | KB | Intercharacter Delay | <KBnumber> |
| | Ka | Host Port | <Kabaud,parity,stop bits,data bits> |
| | Kb | RS-422 | <Kbstatus> |
| | Ky | Aux Port | <Kymode,baud,parity,stop bits,data bits> |
| | KG?1 | Comm. Status Request | <KG?1> |
| Operations | Kg | Triggering Mode | <Kgmode> |
| | Kh | End of Read Cycle | <Khmode,time> |
| | Ki | Serial Trigger Character | <Kicharacter> |
| | Kj | External Trigger Polarity | <Kjmode> |
| | Kk | Noread Message | <Kkstatus,message> |
| | Kl | Bar Code Output | <Klstatus,when to output> |
| | Km | Good Decode Reads | <Kmnumber> |
| | Kn | Match Code | <Kn type,sequential matching,match start position,match length,wild card character,sequence on noread,sequence on every mismatch> |
| | KL | Number of Labels | <KL number of labels,separator character> |
| | KG?2 | Operations Status Request | <KG?2> |
| Code Type | Ko | Narrow Margins/ Symbology ID | <Konarrow margins status,symbology ID status> |
| | Kp | Code 39 | <Kpstatus,check digit,check digit output,large interchar gap,fixed length,length> |
| | Kq | Codabar | <Kqstatus,S/S match,S/S output,large interchar gap,fixed length,length> |
| | Kr | Interleaved 2 of 5 | <Krstatus,check digit,check digit output, length 1,length 2> |
| | Ks | UPC/EAN | <Ksstatus,EAN status,supplementals status, separator status,separator char.> |
| | Kt | Code 128 | <Ktstatus,fixed length,length,UCC/EAN status,format,ap. rec. separator,ap. rec. separator,ap. rec. brackets,ap. rec. padding> |
| | KG?3 | Code Type Status Request | <KG?3> |

Summary of Serial Configuration Commands

Table 3-1 Summary of Serial Configuration Commands

| Function | Cmd | Command Title | Format |
|--------------|------|----------------------------|---|
| User Outputs | Ku | Beeper | <Kustatus,volume> |
| | Kv | Relay Settings | <Kvrelay--output #1 setting,TTL--output #2 setting> |
| | Kz | New Master Pin | <Kzstatus> |
| | KC | Laser On/Off | <KCstatus> |
| | KD | Reverse Video | <KDstatus> |
| | Kw | Output Polarity | <Kwmode> |
| | Kx | Output Pulse Width | <Kxnumber> |
| | KE | Command Start Character | <KEASCII character> |
| | KG | Serial Verification | <KSecho K command,beep on K command,control character output> |
| | KY | Partial Ouput | <KY status,start position,partial length> |
| | KG?4 | User Output Status Request | <KG?4> |
| Raster | KR | Raster Setup | <KRstatus,top offset,bottom offset,motor speed,raster on/off> |

Serial Configuration Command Format

Format: <Kparameterdata,data,...etc.><initializing command>

Where:

- Less than < and greater than > symbols are included as part of the commands.
- “parameter,” as used here, are those character(s) that precede the data.
- the “initializing command” <Z> is sent after configuration is complete to reset and save for power up. If you want to reset without saving for power up, send the command alone.¹

For example, the following command enables UPC: <Ks1>.

When using serial configuration commands, note also the following conventions:

- Parameters and data are “case sensitive.” That is, characters must be entered as upper or lower case, as specified.
- All data fields (except the last) must be followed by a comma (without a space).
- If there is no change in a given field, then commas can be entered alone, or with the existing data (for example, <Ka,,0> or <Ka4,1,0,0>).

1. Commands that effect Communications are unique. See “[Initializing serial configuration commands that effect communications](#)” on page 3-4 for definitions and examples.

- All fields preceding the modified field must be included. For example, in the RS-232 port, to change Data Bits to Eight without changing any other field, enter either: **<Ka,,,1>** or **<Ka4,1,0,1>**.
- All fields following the modified field can be left out. For example, in the RS-232 port, to change Baud Rate to 4800, enter **<Ka3>**.

(See examples on following pages.)

Initializing serial configuration commands that effect communications

For a serial configuration command that effects communications to be implemented, you need to follow it with one of the operational commands below:

- **<A>** To reset but not save changes for power-up
- **<Z>** To reset and save changes for power-up

For example, to change Baud Rate and reset without saving changes for power-up, enter **<Ka3><A>**.

To change Baud Rate and reset, saving the changes to non-volatile RAM, enter **<Ka3><Z>**.

Concatenating Serial Commands

Commands can also be concatenated (added together) to a maximum of 64 characters in a single string or data block. Additional data blocks of 64 or less characters can be sent provided there is at least a 10 ms pause between blocks.¹

For example, the following command, **<Kc1><KA24><Ko1><A>** enables LRC, sets the Host Protocol Response Timeout to 24 ms, enables Narrow Margins and resets the data buffers (without saving the changes for power-on).

Loss of Communications

Assigning a multidrop address to a scanner or making changes to communications parameters such as Baud Rate, Parity, Stop Bits, LRC, etc. without corresponding changes in linked device(s) can result in the loss of menu access. If this should occur, try gaining access to the scanner by entering a **<D>** command from an auxiliary terminal via the auxiliary RS-232 port. If neither of these methods is available, try defaulting the scanner. See [“Appendix E — Defaulting the Scanner” on page A-10](#).

1. Data in excess of 64 characters will reset the buffer, causing the first 64 characters of the string to be lost and indicator #1 to illuminate red 2 seconds after the end of each read cycle, until the scanner's memory is reset.

Communications Commands

Host Protocol

If selecting one of the options from 0 to 4 (Point-to-Point, Point-to-Point with RTS/CTS, Point-to-Point with XON/XOFF, Point-to-Point with XON/XOFF and RTS/CTS, or Polling Mode D), use this format:

Format: **<Kfprotocol>**

protocol:

| | |
|---|-------------------------------------|
| 0 = Point-to-Point | 4 = Polling Mode D |
| 1 = Point-to-Point with RTS/CTS | 5 = Multidrop (requires address) |
| 2 = Point-to-Point with XON/XOFF | 6 = User Defined |
| 3 = Point-to-Point with XON/XOFF and RTS/CTS | 7 = User Defined Multidrop |

Example: To change the Protocol to Polling Mode D, enter **<Kf4>**.

If selecting Multidrop (5), you must define an address and append it to the command string.

Format: **<Kf5protocol,address>**

protocol:

5 = Multidrop

address:

Any number from
1 to 50

Example: To change the Protocol to Multidrop with an address of 33, enter **<Kf5,33>**.

If selecting User Defined (6) or User Defined Multidrop (7), you complete the format by either choosing new parameters or concatenating unchanged data fields (separate by commas).

For User Defined, you first select Point-to-Point **<Kf0>** and then User Defined **<Kf6...>**. For user Defined Multidrop, you first select Multidrop **<Kf5>**, then User Defined Multidrop **<Kf7...>**.

Format: <Kfprotocol,RES,address,REQ,EOT,STX,ETX,ACK,NAK>

Protocol: RES
 6 = User Defined Address
 7 = User Defined Multidrop EOT
 STX
 ETX
 ACK
 NAK

Example: To select an unpolled ACK/NAK User Defined protocol with LRC disabled, enter <Kf0><Kf6,,,,,,,,,^F,^U><Kc0>. ¹ ACK and NAK will be displayed in the menu.²

Note: Address, can be assigned any ASCII character except a null. Control characters are used to define RES through NAK (except Address). [Table 3-2](#) lists the control characters used for these data fields. (Refer to [Table A-1](#), “ASCII Table with Control Characters,” on [page A-5](#) for more information.)

Table 3-2 Protocol Commands

| Protocol Command (Mnemonic displayed on Microscan menu) | Control Characters (Entered in menu or serial command) | Effect of Command |
|---|--|----------------------|
| RES | ^D | Reset |
| REQ | ^E | Request |
| EOT | ^D | Reset |
| STX | ^B | Start of Text |
| ETX | ^C | End of Text |
| ACK | ^F | Acknowledge |
| NAK | ^U | Negative Acknowledge |

1. <Kf0> nulls the address and <Kc0> disables LRC.
 2. A control character, although conventionally represented here and in the ASCII table on [page A-5](#) as two characters (^F or ^U, etc.), is actually a single ASCII character that is entered on the keyboard by holding down the control key while pressing the desired letter.

Preamble

Format: **<Kdstatus,preamble character(s)>**

status: *preamble character(s):*

0 = Disabled Enter one or two preamble characters from [table A-1](#)
1 = Enabled [on page A-5](#), except a null. (00H). Default is **^M**.

Example: To enable Preamble with one character, an FF (form feed), enter **<Kd1,^L>**.

Postamble

Format: **<Kestatus,postamble character(s)>**

status: *postamble character(s):*

0 = Disabled Enter one or two preamble characters from [table A-1](#)
1 = Enabled [on page A-5](#), except a null. (00H). Default is **^M**.

Example: To enable Postamble with an FF (form feed) and a CR (carriage return), enter **<Ke1,^L^M>**.

LRC

Format: **<Kcstatus>**

status:

0 = Disabled 1 = Enabled

Example: To enable LRC, enter **<Kc1>**.

Response Timeout

Format: **<KAtimeout setting>**

timeout setting:

Any number from 0 to 65,000 (a zero creates an indefinite wait). Default is **12**.

Example: To change Response Timeout to 30 ms, enter **<KA30>**.

Intercharacter Delay

Format: **<KBtime interval>**

time interval (in milliseconds between characters):

Any number from 0 to 255.

Default is **0**.

Example: To change Intercharacter Delay to 30 ms, enter **<KB30>**.

Host Port

Note: Changes made in the scanner's communications parameters such as baud rate, parity, stop bits, LRC, etc., must be matched in the other device(s) or communications will be lost. If this occurs, default the scanner as described in [Appendix E — "Defaulting the Scanner."](#)

Format: <Kymode,baud rate, parity,stop bits,data bits>

| baud rate: | parity: | stop bits: | data bits: |
|------------|-----------------|-----------------|----------------|
| 0 = 600 | 4 = 9600 | 0 = None | 0 = One |
| 1 = 1200 | 5 = 19.2K | 1 = Even | 1 = Two |
| 2 = 2400 | 6 = 38.4K | 2 = Odd | 1 = Eight |
| 3 = 4800 | | | |

Example: To change Data Bits to Eight without changing any other fields, enter either <Ka,,1> or <Ka4,1,0,1>.¹

Format: <KbRS-422 status>

RS-422 status:

0 = Disabled 1 = Enabled

Example: To enable RS-422, enter <Kb1>.

This command assumes the scanner is in RS-232 before RS-422 is enabled. If a multidrop address has been already assigned, the scanner will be in RS-485 communications, regardless of displayed RS-422 status.

Auxiliary Port

Format: <Kymode,baud rate, parity,stop bits,data bits>

| mode: | baud rate: | parity: | stop bits: | data bits: |
|---------------------|------------|-----------------|-----------------|----------------|
| 0 = Disabled | 0 = 600 | 4 = 9600 | 0 = None | 0 = One |
| 1 = Transparent | 1 = 1200 | 5 = 19.2K | 1 = Even | 1 = Two |
| 2 = Half Duplex | 2 = 2400 | 6 = 38.4K | 2 = Odd | 1 = Eight |
| 3 = Full Duplex | 3 = 4800 | | | |
| 4 = Daisy Chain | | | | |

Example: To enable Half Duplex and change the baud rate to 2400, enter <Ky2,2>.

Communications Status Request

Format: <KG?1>

Returns status of each command in the group.

1. See "Serial Configuration Command Format," on page 3-3.

Operations Commands

Triggering Mode

Format: <Kgmode>

mode:

| | |
|------------------------------|------------------------|
| 0 = Continuous Read | 3 = External Edge |
| 1 = Continuous Read 1 Output | 4 = Serial Data |
| 2 = External Level | 5 = Serial Data & Edge |

Example: To select External Edge, enter <Kg3>.

End of Read Cycle

Format: <Khend of read cycle, timeout>

end of read cycle: timeout:

| | |
|---------------------------|--|
| 0 = Timeout | When enabled, the default is one second. To change, enter a number between 0 and 65535. |
| 1 = New Trigger | (This number is in 10 ms increments and is derived by multiplying the desired number of seconds by 100.) |
| 2 = Timeout & New Trigger | |

Example: To select Timeout and change the timeout value to 6 seconds, enter <Kh0,600>.

Serial Trigger Character¹

Format: <Kitrigger character>

serial trigger character:

Enter any available ASCII character (see [table A-1 on page A-5](#)). Default is ^].

Example: To define the Serial Trigger Character as a lowercase c, enter <Kic>.

External Trigger Polarity

Format: <Kjpolarity>

polarity:

| | |
|--------------|---------------------|
| 0 = Negative | 1 = Positive |
|--------------|---------------------|

Example: To change External Trigger Polarity to Negative, enter <Kj0>.

1. Selecting a serial trigger character that is also an operational command will make that operational command unavailable, although the trigger will work. For example, an uppercase C cannot be used as a serial trigger character because it is the operational command for Enter Read Rate Test. However, a lowercase c could be used without interfering with the read rate test.

Noread Message

Format: <Kkstatus,message>

| | |
|--------------------|----------------------------------|
| <i>status:</i> | <i>message:</i> |
| 0 = Disabled | Any ASCII string up to 7 digits. |
| 1 = Enabled | Default is NOREAD . |

Example: To enable Noread Message and enter the message "FAIL," enter <Kk1,FAIL>.

Bar Code Output

Format: <Klstatus,when to output>

| | |
|--------------------|--------------------------------|
| <i>status:</i> | <i>when to output:</i> |
| 0 = Disabled | 0 = As Soon As Possible |
| 1 = Enabled | 1 = End of Read Cycle |

Example: To set Bar Code Output to End of Read Cycle, enter <Kl1,1>.

Good Decode Reads

Format: <Kmnumber>

number of reads:
Any number from 1 to 31

Example: To change Number of Reads to 3, enter <Km3>.

Match Code

Format: <Kn^{type},^{sequential matching},^{match start position},^{match length},^{wild card character},^{sequence on noread},^{sequence on every mismatch}>

| | | |
|-----------------------|----------------------------|-----------------------------|
| <i>type:</i> | <i>sequential matching</i> | <i>match start position</i> |
| 0 = Disabled | 0 = Increment | Default is 0 |
| 1 = Enabled | 1 = Decrement | 0 to 31 |
| 2 = Wild Card | | |
| 3 = Sequential | | |
| <i>match length</i> | <i>wild card character</i> | |
| Default is 1 . | Default is * . | |
| 1 to 31 | Any ASCII character. | |

sequence on noread:

0 = disabled **1 = enabled**

When disabled, the scanner does not sequence (increment or decrement) on a noread. If 001, 002, noread, then search for 003.

When enabled, the scanner sequences on every noread. If 001, 002, noread, then search for 004.

sequence on every mismatch:^a

0 = disabled 1 = enabled

When disabled, if a mismatch is out of sequence by no more than 1, then the sequence resumes and searches indefinitely. If 001, 002, 004 (mismatch), then search for 005.

When enabled, the scanner sequences on every mismatch. If 001, 002, mismatch, then search for 004. If mismatch occurs again, then search for 005, etc.

Example: To enable Match Code Type for Sequential, set Sequential Matching for Decrement, and enable Sequence on Every Mismatch, enter **<Kn2,1,,,,,1>**.

Number of Labels

Format: **<KLnumber of labels,field separator>**

number of labels:

field separator:

| | | |
|----------------------|-----------------|------------------------------------|
| 0 = One label | 3 = Four labels | Any ASCII character, except a NUL. |
| 1 = Two labels | 4 = Five labels | Default is a comma (,). |
| 2 = Three labels | 5 = Six labels | |

Example: To set Number of Labels to four labels with a dash (-) for a Field Separator, enter **<KL3,->**.

Trigger Filter Timing Value

Format: **<KF?>**

Returns the current trigger filter timing value in milliseconds.

Format: **<KFone tenth trigger filter timing value>**

Allows you to set trigger filter timing. Divide the desired number of milliseconds by 10 and enter the quotient.

Operations Status Request

Format: **<KG?2>**

Returns status of each command in the group.

3-Serial Config.

Code Type Commands

Narrow Margins/Symbology ID

Format: **<Konarrow margins status,symbology ID status>**

narrow margins status: *symbology ID status:*

0 = Disabled **0 = Disabled**

1 = Enabled 1 = Enabled

Example: To enable Narrow Margins and Symbology ID, enter **<K01,1>**.

Code 39

Format: **<Kpstatus,c/d status,c/d output,interchar gap,fixed length status,code length>**

status: *check digit status:* *check digit output status:*

0 = Disabled **0 = Disabled** **0 = Disabled**

1 = Enabled 1 = Enabled 1 = Enabled

large interchar. gap status: *fixed code length status:* *code length:*

0 = Disabled **0 = Disabled** Any number from 1 to

1 = Enabled 1 = Enabled 31. Default is **10**.

Example: To enable Code 39 and set Fixed Code Length to 30, enter **<Kp1,,,,,1,30>** or **<Kp1,0,0,0,1,30>**.

Codabar

Format: **<Kqstatus,s/s status,s/s output,interchar gap,fixed length,code length>**

status: *start & stop match status:* *start & stop output status:*

0 = Disabled 0 = Disabled 0 = Disabled

1 = Enabled **1 = Enabled** **1 = Enabled**

large interchar. gap status: **0 = Disabled** *fixed code length status:* **0 = Disabled** *code length:*

1 = Enabled 1 = Enabled Any number from 1 to

31. Default is **10**.

Example: To enable Codabar and set Fixed Code Length to 9, enter **<Kq1,,,,,1,9>** or **<Kq1,1,1,0,1,9>**.

I 2 of 5

Format: **<Krstatus,c/d status,c/d output,code length#1,code length#2>**

| | | |
|---------------------|---------------------------|---------------------------------|
| <i>status:</i> | <i>check digit output</i> | <i>code length#1:</i> |
| 0 = Disabled | <i>status:</i> | Zero or any even number from |
| 1 = Enabled | 0 = Disabled | 2 to 30. Default is 10 . |
| | 1 = Enabled | |

| | |
|----------------------------|--------------------------------|
| <i>check digit status:</i> | <i>code length #2:</i> |
| 0 = Disabled | Zero or any even number from |
| 1 = Enabled | 2 to 30. Default is 6 . |

Example: To enable I 2 of 5 and to set Fixed Code Length # 1 to 8 and Fixed Code Length # 2 to 4, enter **<Kr1,,,8,4>** or **<Kr1,0,0,8,4>**.

UPC/EAN

Format: **Ksstatus,EAN,supplementals,separator,separator char>**

| | | |
|---------------------|--|------------------------------|
| <i>status:</i> | <i>EAN status:</i> | <i>supplementals status:</i> |
| 0 = Disabled | 0 = Disabled | 0 = Disabled |
| 1 = Enabled | 1 = Enabled (UPC must also be enabled) | 1 = Enabled |
| | | 2 = Required |

| | |
|--------------------------|--|
| <i>separator status:</i> | <i>separator character:</i> |
| 0 = Disabled | Any ASCII character except NUL. Default is a comma |
| 1 = Enabled | (,). |

Example: To enable UPC and EAN, change Supplementals to required, and change Separator Character to a dash (-), enter **<Ks1,1,2,1,->** or **<Ks1,1,2,,->**.

Code 128

Format: <Ktstatus, fixed length, code length, status, format, ap. rec. separator, ap. rec. separator, ap. rec. brackets, ap. rec. padding>

| | | |
|--------------------------------------|----------------------------------|---|
| <i>status:</i> | <i>fixed code length status:</i> | <i>code length:</i> |
| 0 = Disabled | 0 = Disabled | Any number from 1 to 31. Default is 10 . |
| 1 = Enabled | 1 = Enabled | |
| <i>status (UCC/EAN-128): format:</i> | | |
| 0 = Disabled | 0 = Standard | |
| 1 = Enabled | 1 = Application Record | |

Example: To enable Code 128, enable Fixed Code Length, and set Code Length to 9, enter <Kt1,1,9>.

| | | |
|-------------------------------------|--|---------------------------|
| <i>ap. rec. separator (status):</i> | <i>ap. rec. separator (define):</i> | <i>ap. rec. brackets:</i> |
| 0 = Disabled | Any ASCII char. except a null. Default is a comma (,). | 0 = Disabled |
| 1 = Enabled | | 1 = Enabled |

ap. rec. padding:
 0 = Disabled
1 = Enabled

Example: To enable UCC/EAN, enable Application Record, and define / as a separator, enter <Kt1,,,1,1,1,/>.

Code Types Status Request

Format: <KG?3>

Returns status of each command in the group.

User Outputs Commands

Beeper

Format: <Kuoutput,volume>

| | | |
|-----------------------|-----------------------|--------------------|
| <i>beeper status:</i> | <i>beeper volume:</i> | |
| 0 = Disabled | 0 = Level 1 | 3 = Level 4 |
| 1 = On Good | 1 = Level 2 | 4 = Level 5 |
| 2 = On Noread | 2 = Level 3 | |

Example: To set the beeper for On Noread and set the beeper volume to Level 5, enter <Ku2,4>.

Relay Settings

Format: <Kvrelay--output #1 setting,TTL--output #2 setting>

| | |
|----------------------------------|--------------------------------|
| <i>relay--output #1 setting:</i> | <i>TTL--output #2 setting:</i> |
| 0 = Good Match | 0 = Good Match |
| 1 = Mismatch | 1 = Mismatch |
| 2 = Noread | 2 = Noread |
| 3 = Mismatch or Noread | 3 = Mismatch or Noread |

Example: To change Relay--Output #1 to Noread, enter <Kv2>.

See ["Relay Settings," on page 2-32.](#)

New Master Pin

Format: <Kzstatus>

status:
0 = Disabled 1 = Enabled

Example: To enable New Master Pin, enter <Kz1>.

Laser On/Off

Format: <KCstatus>

status:
0 = Disabled 1 = Enabled

Example: To enable Laser On/Off, enter <KC1>.

Reverse Video

Format: <KDstatus>

status:

0 = Disabled 1 = Enabled

Example: To enable Reverse Video, enter <KD1>.

Output Polarity

Format: <Kwpolarity>

polarity:

0 = Negative

1 = Positive

Example: To change Output Polarity to Negative, enter <Kw0>.

Output Pulse Width

Format: <Kxpulse width>

duration of relay pulse:

Any number from 0 to 255.

Default is **5** (50 ms).

Example: To set Output Pulse Width to 600 ms, enter <Kx60>.

Command Start Character

Format: <KEcharacter>

command start character:

Any ASCII character. Default is <.

Example: To change Command Start Character to a colon (:), enter <KE:;>.

Note: Subsequent commands must start with a colon (:). For example, enter :D> to access the menu, or :KE<> to change back to the default character.

Partial Output

Format: <KYstatus,partial start position,partial length>

partial output status: partial start position: partial length:

0 = Disabled **Default is 1** **Default is 31**

1 = Enabled 1 to 31 1 to 31

Example: To enable Partial Output, set start position to 5, and set length to 6 characters, send <KY1,5,6>.

See ["Partial Output" on page 2-36](#).

Serial Verification

<**KS**echo K command,beep on K command,control character output>

echo K command: beep on K command: control character output:

0 = Disabled **0 = Disabled** **0 = Control**
1 = Enabled 1 = Enabled 1 = Hex

Example: To enable Echo K Command, Beep on K command, and Control Character Output, enter <**KS1,1,1**>.

User Outputs Status Request

Format: <**KG?4**>

Returns status of each command in the group.

Raster Setup Commands

Format: <**KR**status,top offset,bottom offset,motor speed,raster on/off>

| | |
|---|--|
| status: | top offset in degrees: |
| 0 = Disabled | Any number from 0 to 45. |
| 1 = Enabled | Default is 0 . |
| bottom offset in degrees: | motor speed in sweeps per second: |
| Any number from 0 to 45. Default is 45 . | Any number from 0 to 135. Default is 14 . |
| raster on/off: | |
| 0 = Disabled 1 = Enabled | |

Example: To set Raster Arc to 35°, Sweeps per Second to 10, and not change Raster On/Off, enter <**KR1,5,40,10**>.

See [“Raster Setup Menu” on page 2-37](#).

Calibration

Chapter Contents

| | |
|----------------------------------|-----|
| About Calibration | 4-2 |
| Autocalibration | 4-2 |
| By Serial Command | 4-2 |
| By Menu Command | 4-3 |
| Other Menu Parameters..... | 4-5 |
| Recalling Factory Settings | 4-6 |
| Saving Current Settings..... | 4-6 |
| Motor Speed | 4-6 |
| Gain..... | 4-7 |
| Tracking..... | 4-8 |
| Bandwidth..... | 4-8 |
| Clock Speed | 4-8 |
| Bar Size Measurements..... | 4-9 |
| Scan Rate | 4-9 |

Caution: Defaulting the scanner will recall factory calibration settings that may require you to repeat Autocalibration and /or reenter individual calibration settings.

This chapter describes the steps for doing Autocalibration, Motor Speed, and other adjustments that are performed in the Calibration Setup menu

About Calibration

Changes to motor speed, gain, tracking, bandwidth, clock speed, and bar size measurement to the MS-7100/7180 can be made manually (by individual menu commands) or automatically to gain and tracking by “Autocalibration.” Of these, Autocalibration and Motor Speed are the most useful for improving read rates. You can make changes to any of these parameters by accessing the Calibration Setup menu, and in the case of Autocalibration, by serial command or menu command.

Autocalibration

Note: Ensure that the scanner’s laser is on and that the label being scanned is of a code type enabled in the scanner’s software. (See “Code Types Menu” on page 2-22.)

For most applications, Autocalibration is the only necessary adjustment. This procedure maximizes read rate by automatically cycling through the scanner’s gain and tracking potentiometer settings until the optimum settings are obtained for the highest read rates.

Read rate represents the ratio of good decodes per scans. Ideally, 100% is the optimum read rate. However, in most applications, variations in label quality, label placement, etc. will result in some falling off of the read rate. The object of Autocalibration is to significantly improve read rates, if not to 100%, then to a rate approaching it.

You can do autocalibration by serial command alone or by menu.

By Serial Command

1. Place your sample label at a fixed position at the maximum range from a scanner as required for your application.
2. Unless you have made changes to parameters that need to be preserved, recall factory settings by sending a <KTD>.
3. To initiate autocalibration by serial command only, send a <KT> Command.

Allow some time for the scanner to cycle through the gain and tracking settings. Do not move or disturb scanner or label while Autocalibration is in progress. When completed, the settings that provided the highest read rate will be selected.

4. To save the settings changed in Autocalibration for power-up, send a <KTZ> command.

By Menu Command

1. Place your sample label at a fixed position at the maximum range from a scanner as required for your application.
2. Send a <t> command to enter the calibration menu.

```
-----
Gain |Motor|Track| Big |Small| Scan |
      |    |     | Bar | Bar | Rate |
51   | 80 | 11 | 147 | 75 | 00960|66% 1234567890
```

You will see a read rate percentage from 0 to 100 (66% in the above example) displayed on the bottom line to the right of Scan Rate, followed by the sample label's data.

3. Unless you've made changes to parameters that need to be preserved, recall factory settings by typing an upper case **D** if in the menu program.

If in the menus, the following message will be displayed to the right of Scan Rate:

```
-----
Gain |Motor|Track| Big |Small| Scan |
      |    |     | Bar | Bar | Rate | Factory settings restored.
118  | 80 | 128 | 158 | 75 | 00960|74% 1234567890
```

4. If your application requires a change in scan rate, do motor speed adjustment now. (See "Motor Speed" on page 4-6.)
5. Start Autocalibration by typing an upper case **A** from your terminal while in the calibration menu. An "Autocalibration in progress" message will be displayed as shown below:

```
-----
Gain |Motor|Track| Big |Small| Scan |
      |    |     | Bar | Bar | Rate | Autocalibration in progress
118  | 80 3 | 128 | 158 | 75 | 00960|72% 1234567890
```

Note: Keystrokes will have no affect until Autocalibration is completed.

Allow some time for the scanner to cycle through the gain and tracking settings. Do not move or disturb scanner or label while Autocalibration is in progress. When completed, the settings that provided the highest read rate will be selected and "Autocalibration complete" will be displayed as follows:

```
-----
Gain |Motor|Track| Big |Small| Scan |
      |    |     | Bar | Bar | Rate | Autocalibration complete
118  | 80 | 128 | 159 | 75 | 00960|82% 1234567890
62   | 80 | 1 | 158 | 83 | 00960|100% 1234567890
```

Note that the new values are displayed on the bottom line with the older values (those current at the time Autocalibration was invoked) posted immediately above them for comparison. These in turn will be replaced by the current bottom line values if and when Autocalibration is repeated.

If the results of Autocalibration are not satisfactory, you might improve performance by changing Motor Speed Pot (scan rate), changing the label position relative to the scanner, or other parameters listed in this chapter and in Step 10, "Adjust Other Scanning Parameters," on page 1-16.

If label placement or other changes have been made, recalculate the number-of-scans and repeat Autocalibration.

If the scanner was unable to decode the label, "Autocalibration failed" will be displayed, as follows:

```

-----
Gain | Motor | Track | Big | Small | Scan |
      |      |      | Bar | Bar  | Rate | Autocalibration failed
62   | 80   | 1    |     |     | 00960 | 0%
62   | 80   | 1    |     |     | 00960 | 0%
    
```

- Record label, range, gain, motor, tracking, and read rate values for future reference.

Depending on your application, you might want to check for depth-of-field (minimum/maximum range) by moving the label in and out relative to the scanner and noting the points at which the read rates on the calibration screen fall below your acceptable level.

- Autocalibration:by menu commandTo exit the Calibration menu, press the ESC key. You will see the following prompt on the: bottom line

```
| Do you want to save calibration settings for power on? (Y=yes N=no)
```

Caution: Restoring factory settings will change Gain and Tracking settings and hence nullify the changes made by the autocalibration procedure.

Other Menu Parameters

The Calibration Setup menu allows you to monitor read rate and other parameters and to adjust internal scanner functions by software commands to improve read rate performance. It is particularly useful for adjusting to poorer quality labels or labels placed on the fringes or beyond the recommended read ranges. The Calibration Setup menu is launched from the terminal keyboard with a <t> command (see Chapter 5, “Operational Commands”) to the scanner.

```

MICROSCAN SYSTEMS INC. 1993 (C)
35-227001-XX
Calibration Setup Menu
=====
To make changes, press appropriate key from list below:
START AUTO-CALIBRATION.....A
RECALL FACTORY SETTINGS.....D
< Motor Speed Pot >.....M = INCREMENT.....N = DECREMENT
< Gain Pot >.....G = INCREMENT.....F = DECREMENT
< Tracking Pot >.....T = INCREMENT.....R = DECREMENT
< Bandwidth >.....B = HIGH/ LOW
< Clock Speed >.....C = FAST/SLOW
EXIT Calibration Setup menu.....ESC
=====
A_Bdwth=HIGH Clk=FAST Laser=ON Motor=ON
=====
|      |      | Big | Small | Scan |
Gain | Motor | Track | Bar | Bar | Rate |
115 | 80 | 2 | 255 | 126 | 00980 | 0%

```

Figure 4-1 Calibration Setup Menu

Bandwidth and Clock status, along with Laser and Motor are shown on a single line in the bottom half of the menu as A_Bdwth, Clk, Laser, and Motor.

Motor Speed Pot, Gain Pot, and Tracking Pot adjustments control potentiometers (variable resistor circuits) that are incremented or decremented by pressing the indicated key one stroke at a time to change slowly, or by holding down the key to change quickly. The status of these three parameters is displayed on the bottom line of the menu under Gain, Motor, and Track. Bandwidth and Clock Speed use single commands (B and C respectively) to toggle between states.

Big Bar and Small Bar measure bar widths and are not adjustable. Scan Rate is the number of scans per second and will change in response to changes in Motor Speed. To the immediate right of Scan Rate is the read rate, that is shown below as 66%. To the right of this is the current label data, in this example, 1234567890.

```

-----
Gain | Motor | Track | Big | Small | Scan |
Bar | Bar | Rate |
51 | 80 | 11 | 147 | 75 | 00960 | 66% 1234567890

```

Values displayed on the bottom line of the Calibration Setup menu, from Gain through Small Bar, are updated during operation, without refreshing the screen.

Recalling Factory Settings

The original factory settings for the five parameters (Motor Speed Pot through Clock Speed) of the Calibration Setup menu can be restored by typing an upper case D,¹ or by defaulting the scanner, recalling settings for both the calibration and the configuration menus.

Saving Current Settings

Current Calibration settings can be saved to non-volatile RAM for power-up by typing Y upon exiting the Calibration Setup menu.

To save changes when exiting the Calibration Setup menu,

1. Press the ESC key. You will see the following prompt on the bottom line:

```
|Do you want to save changes for power on ? (Y=yes N=no)
```

2. Press Y to save current settings for power on or N to exit without saving.

Note: Choosing Y will only save current settings that have been made in the Calibration menu and not affect the Configuration menu settings.

Motor Speed

Motor Speed directly effects scan rate (scans per second). The scanner is factory-set at the upper rate of 1000 scans per second, although it can be set to rates as low as 600. A slower scan speed may improve small bar acquisition (see “Small Bar” on page 4-9), and allow greater label range. However, before changing the motor speed, first determine if the number of scans for your application will be sufficient at the new speed. (See Step 5, “Calculate Number of Scans,” on page 1-6.)

1. Commands issued from inside the Calibration Setup menu do not require any brackets.

To adjust Motor Speed:

1. Place the label to be used in your application at the desired range from a scanner in a fixed position.
2. From your terminal enter <t>.
3. From your terminal, enter a series of upper case Ns to decrease scan speed or upper case Ms to increase scan speed.

This will change both Motor and Scan Rate values on the bottom line of the Calibration Setup menu.¹ Motor values range from 1 to 80 (or higher) corresponding to 600 to 1000 scans per second (displayed under Scan Rate).

4. Recalculate the number of scans.
5. When the desired number of scans is reached, do “Autocalibration” starting with 5 on page 4-3.

Gain

Adjusts the gain potentiometer for an optimum signal when testing a specific label and range.

Gain is set during Autocalibration but can be user-adjusted if circumstances warrant.

To manually optimize Gain,

1. Position label in read range and enter the Calibration Setup menu by typing <t>.
2. Observe the read rate on the right side of the bottom line of your screen.
3. Press G to increment or F to decrement Gain while observing the read rate and relative values displayed under Gain on the bottom line of the Calibration menu.

Displayed values for Gain range from 0 to 255.

Note: If electronic AGC is enabled (default), Gain may have little or no effect on read rate.

1. Scan Rate setting requires some time to stabilize after Motor adjustments are made.

Tracking

Adjusts tracking potentiometer of analog-to-digital converter that affects the accuracy of the digitized signal.

As with Gain, Tracking is set in Autocalibration but can be user-adjusted if circumstances warrant.

To manually optimize Tracking,

1. Follow the same steps described for Gain except press T to increment and R to decrement. Values for Tracking can range from 1 to 255.
2. Observe the read rate and relative values displayed under "Track" on the bottom line of the Calibration menu.

Bandwidth

Controls the range of frequencies (energy transitions) that are allowed to pass through bandpass filters during signal processing. Generally, Bandwidth should remain in the factory-set HIGH position for maximum resolution. However, with low density labels at close range or poorly printed labels, changing Bandwidth to LOW may improve readability by accepting a narrower range of frequencies.

To change Bandwidth,

1. Place the label to be used in your application at the desired range from the scanner in a fixed position.
2. From your terminal send a <t> (Enter Calibration Setup command) to the scanner.
3. Press B to toggle between LOW and HIGH.

The resulting change will be displayed on the status line of the Calibration Setup menu.

4. Do "Autocalibration" starting with 5 on page 4-3.

Clock Speed

Relates to internal decoder timing relative to individual bars and spaces.

Note: *Clock speed has no relationship to scan speed.*

Clock Speed is either FAST (factory set) or SLOW and displayed on the status line about one quarter distance from the bottom of the Calibration Setup menu. The default FAST Clock Speed allows better acquisition on narrower bar-width labels, or labels at greater distances from the scanner; a

SLOW Clock Speed may in some instances improve acquisition on wider bar-width labels or labels at closer distances.

To change Clock Speed,

1. Place the label to be used in your application at the desired range from the scanner in a fixed position.
2. From your terminal send a <t> (Enter Calibration Setup command) to the scanner.
3. Press C to toggle between SLOW and FAST.

The resulting change will be displayed on the status line of the Calibration Setup menu.

4. Do “Autocalibration” starting with 5 on page 4-3.

Bar Size Measurements

Measures relative bar sizes in terms of scan duration (clock cycles).

Big Bar and Small Bar cannot be directly adjusted but will change in response to changes in narrow-bar-width type, range, and motor speed.

They are updated continuously in response to sensor input.

Big Bar

Measures large bar widths in logarithmic values corresponding to clock cycles. Maximum Big Bar value will never exceed 255 (1024 clock cycles).

Small Bar

Measures small bar widths in logarithmic values corresponding to clock cycles. Minimum Small Bar value will not fall below 75 (approximately 8 clock cycles).

If a consistent minimum read of 75 is displayed, try decreasing motor speed (see “Motor Speed” on page 4-6) or label range until the small bar display rises slightly above 75.

Scan Rate

Scan Rate is the scans per second of the laser beam that the scanner produces in operation, with laser scanning enabled.

The standard range for Scan Rate is 600 to 1000 scans per second.

Changes to Scan Rate take place in response to changes in Motor Speed. (See “Motor Speed” on page 4-6 for information on changing Scan Rate.

Chapter 5

Operational Commands

Chapter Contents

| | |
|--------------------------------------|-----|
| Summary of Operational Commands..... | 5-2 |
| Program Management Commands..... | 5-3 |
| Device Control Commands..... | 5-3 |
| Code Type Commands..... | 5-4 |
| Counter Commands..... | 5-4 |
| Test Commands..... | 5-5 |
| Status Commands..... | 5-5 |
| Master Label Commands..... | 5-5 |

This chapter describes the scanner's serial operational commands and their functions.

On-line serial operational commands are sent from the host to the scanner to carry out routine operations "on the fly" as distinguished from serial configuration commands that are generally used in initial setup.¹

Operational commands are always preceded by a < left angle bracket symbol (unless redefined by Command Start Character command) and followed by a > right angle bracket symbol.²

1. The scanner will only recognize a <D> serial command (Enter Menu Configuration Program) from an auxiliary terminal.
2. Command start character by default is a left angle bracket, <. It may be redefined by menu or serial command. However, the end character, a right angle bracket, >, cannot be changed.

Summary of Operational Commands

Table 5-1 Operational Commands

| Command Type | Command | Result |
|--------------------|----------|---|
| Program Management | <A> | Software Reset (does not save for power-on) |
| | <D> | Enter Configuration Mode |
| | <Z> | Save Configuration for Power-on |
| | <t> | Enter Calibration Setup menu |
| | <KT> | Autocalibration initiation |
| | <KTD> | Autocalibration factory default |
| | <KTZ> | Save autocalibration |
| Device Control | <Bdata> | Echo Data to Aux Monitor |
| | <H> | Enable Laser Scanning |
| | <I> | Disable Laser Scanning |
| | <L> | Host Relay Driver |
| Code Type | <P> | Autodiscriminate All Codes |
| | <Q> | Enable Code 39 Only* |
| | <R> | Enable Codabar Only* |
| | <S> | Enable I 2 Of 5 Only* |
| Counter | <N> | Noread Counter |
| | <O> | Noread Counter Reset |
| | <T> | Trigger Counter |
| | <U> | Trigger Counter Reset |
| | <V> | Match Code (or Good Read) Counter |
| | <W> | Match Code Counter Reset |
| | <X> | Mismatch Counter |
| | <Y> | Mismatch Counter Reset |
| Test | <C> | Enter Read Rate Test |
| | <m> | Enter Scan Rate Test |
| | <J> | Exit Read Rate or Scan Rate Test |
| Status | <#> | Display Software Part Number |
| | <!> | Display Checksum of EPROM |
| Master Label | <E> | Enable Match Code Option* |
| | <F> | Disable Match Code Option* |
| | <G> | Store Next Label Scanned as Master Label |
| | <)XXXX)> | Download Master Label Information |
| | <)> | Request Master Label Information |
| | <)> | Delete Master Label Information |

* Can also be accomplished in configuration menu and serial configuration command.

Program Management Commands

<A> Software Reset. Initializes all serial configuration commands in RAM and resets all counters and operating parameters. Changes for Baud Rate, Stop Bits, Code Length, etc. do not take effect until this command is sent.

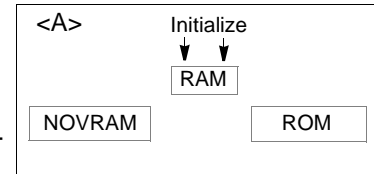

Note: *Software Reset will cause the numeric counters in use to lose their count; record all data that you wish to save prior to sending this command.*

<D> Enter Configuration Menu. Enters the menu configuration program. (Can be entered from the auxiliary port.)

<Z> Save Configuration for Power-on.

Saves the current configuration to nonvolatile memory for availability on power-on. The values of numeric counters are not saved by this command.

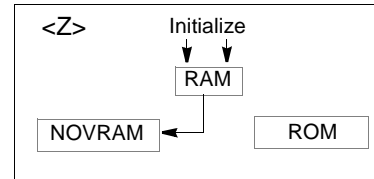

Note: *The <Z> Save Configuration command can be executed 10,000 times. In normal usage this will exceed the life of the decoder. If frequent changes to the operating parameters are required, the <Z> command should be used only when the current configuration has been changed and the changes are to be permanent.*

<t> Calibration (Setup Menu). Allows you to monitor the scanner's optical parameters, optimize performance, and make custom adjustments for special applications. (Can be entered from the auxiliary port.)¹

<KT> Autocalibration Initiate. Initiates autocalibration changes and internal scanner settings. (See

<KTD> Autocalibration Default. Resets autocalibration and motor speed settings to factory defaults.

<KTZ> Autocalibration Save. Saves the settings changed in autocalibration for power up.

Device Control Commands

<Bdata> Echo Data to Aux Monitor. Echoes data from host to auxiliary monitor (see [Appendix I, "Auxiliary Monitor,"](#) on page A-16 for more detail).

<H> Enable Laser Scanning. Normal Operation.

1. The <D> and <t> commands are the only commands that the MS-7100/7180 scanner will recognize from an auxiliary terminal.

<I> Disable Laser Scanning. This feature is useful during extended periods of time when no bar code labels are being scanned. Disabling laser scanning will not affect any downloaded commands to the scanner.

<L> Host Relay Driver. Allows you to send a pulse (at any time regardless of Match Code or Relay Settings status) to internal relay contacts to make or break a connection between pins 7 and 9 of both the power and trigger connectors.

Code Type Commands

<P> Autodiscriminate All Codes. Enables the scanner to decode all available bar code types without changing scanner configuration settings

Note: For maximum scanning speed, enable only those bar code symbologies used in the application.

<Q> Enable Code 39 Only. Allows only Code 39 labels to be read.

<R> Enable Codabar Only. Allows only Codabar labels to be read.

<S> Enable I 2 of 5 Only. Allows only Interleaved 2 of 5 labels to be read.

Counter Commands

The Xs in all counter commands denote a numeric value from 00000 to 65,535. After reaching the maximum numeric limit of 65,535, you will receive an error message and the counter will automatically rollover and start counting again at 00000. To obtain the cumulative total of counts after the rollover has occurred, add 65,536 per each rollover (the decoder does not keep track of the number of rollovers) to the current count.

Note: You will lose all counter values if power to the scanner is cycled, an <A> command is sent, or upon entering and exiting Configuration or Calibration Setup menus.

Note: If you activate the counter command during a read cycle, the scanner will not output the count until the read cycle ends.

<N> Noread Counter. The message N/XXXXX displays the total number of noreads that have occurred since power-on or the last Noread Counter Reset command.

<O> Noread Counter Reset. Sets Noread Counter to 00000.

<T> Trigger Counter. The message T/XXXXX displays the total number of triggers since power-on or the last Trigger Counter Reset command.

<U> Trigger Counter Reset. Sets the trigger counter to 00000.

<V> Match Counter (or Good Read Counter). The message V/XXXXX displays the total number of good reads matching the master label since power-on

or the last Match Counter Reset command. This counter is always enabled, but will only work as a match count when Match Code option is enabled. If the Match Code option is not enabled, this counter records the number of good reads, or decodes. This count can be requested at any time.¹

<W> Match Counter Reset. Sets the Match Counter to 00000.

<X> Mismatch Counter. The message X/XXXXX displays the number of labels successfully read that do not match the master label since power-on or the last Mismatch Counter command.

<Y> Mismatch Counter Reset. Sets the Mismatch Counter to zero.

Test Commands

<C> Enter Read Rate Test. Instructs the decoder to output the percentage of scans decoded. The read rate can vary dramatically due to the angle and location of the label in relation to the scan beam. This test is very useful in aligning and positioning the scanner during installation.

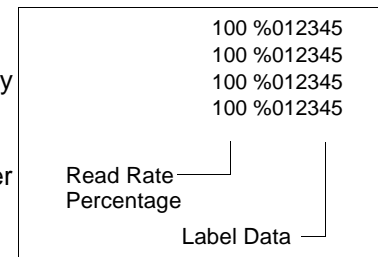

<m> Enter Scan Rate Test. Displays the current number of scans per second produced by the spinning mirror.

<J> Exit Read Rate or Scan Rate Test. Ends the read rate test or scan rate test and returns to read or ready mode.

Note: Read rate and scan rate are also displayed in the Calibration Setup menu. See [“About Calibration,” on page 4-2.](#)

Status Commands

<#> Display Software Part Number. Displays software part number.

<!> Display Checksum of EPROM. Displays a four-digit hex number (corresponding to a given firmware version) used to verify a scanner's EPROM.

Master Label Commands

<E> Enable Operational Commands:master labelMatch Code Option.

Identical to Match Code command in [Chapter 2, “Menu Configuration,”](#)

Instructs the scanner to compare bar code labels being scanned with a master label that has been entered in nonvolatile or volatile RAM, and may under certain conditions open or close an internal relay connected to external pins and send TTL pulses to pins on the host, power, and trigger connectors. (See

1. Can also be used as a good read counter when Match Code is not enabled.

“Relay Settings,” on page 2-32.) If no master label has been entered, every decoded label will be a “mismatch” and will increment the mismatch counter by one.

Enable Match Code Option is intended for use when the scanner is in a triggered mode. If the Match Code option is enabled in the Continuous Read mode, the scanner defaults to Continuous Read One Output mode, and the label data must change before the scanner will output data again, unless a timeout, if enabled, occurs.

See “Match Code,” on page 2-19 and “Relay Settings,” on page 2-32.

<F> Disable Match Code Option. Disables Match Code.

<G> Store Next Label Scanned as Master Label. Causes the scanner to use the next bar code label read as the master label if Match Code option has been enabled. All subsequently decoded labels are compared against the master label information stored in RAM. (See “Match Code,” on page 2-19.)

<)XXXX> Download Master Label Information. Downloads master label information from the host or a terminal. The master label information can be downloaded at any time, and can be saved in nonvolatile memory with a <Z> command. A stored master label will not affect standard operation unless Match Code option is enabled.

The Xs denote alphanumeric data, from 1 to 31 characters.

<I> Request Master Label Information. Immediately sends the master label information to the host. To prevent conflicts with outputting label data, first send the <I> command (Disable Laser Scanning (Laser Off)).

<J> Delete Master Label Information. Deletes master label information that has previously been loaded by either <)XXXX> Download Master Label Information Command or <G> Store Next Label as Master Label command.

Note: If the master label information has previously been stored in nonvolatile RAM (by a <Z> command), sending an <A> Reset or cycling the power will restore that information.

Appendices

Contents

| | |
|--|------|
| Appendix A — Scanner Specifications | A-2 |
| Appendix B — ASCII Table..... | A-5 |
| Appendix C — Orientation | A-6 |
| Appendix D — Ground and Shield Considerations..... | A-9 |
| Appendix E — Defaulting the Scanner | A-10 |
| Appendix F — Troubleshooting | A-11 |
| Appendix G — Bar Code Symbology..... | A-14 |
| Appendix H — Interface Standards | A-15 |
| Appendix I — Auxiliary Monitor..... | A-16 |
| Appendix J — Multidrop Communications | A-21 |
| Appendix K — Glossary of Terms..... | A-25 |

Appendix A — Scanner Specifications

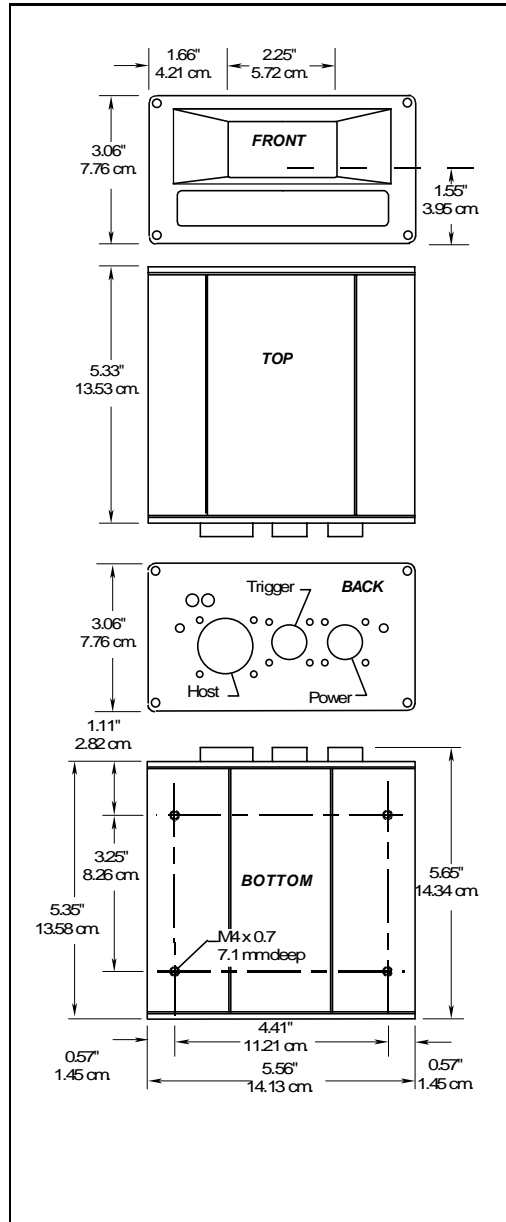

Figure A-1 MS-7100 Scanner Dimensions

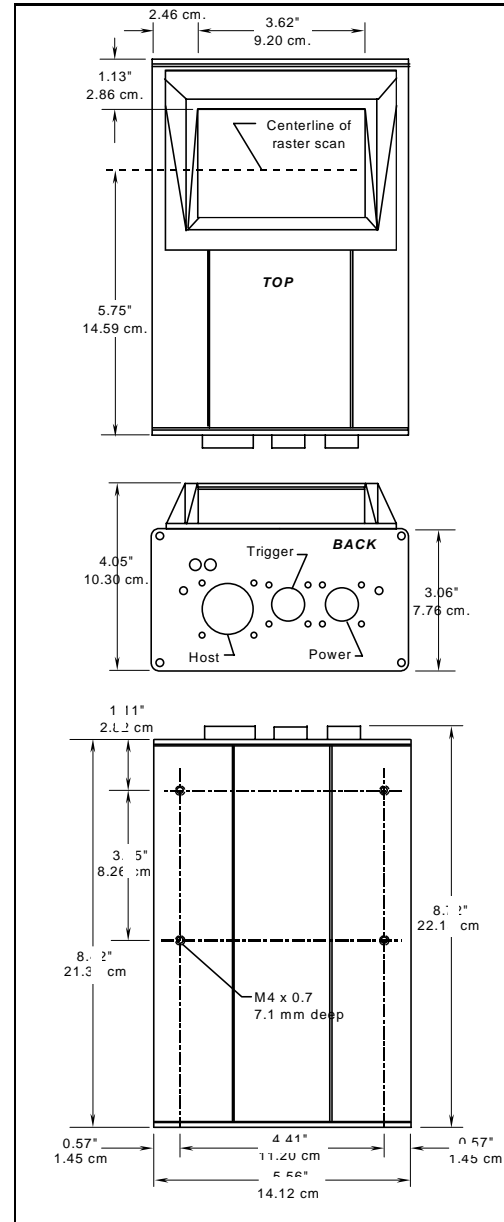

Figure A-2 MS-710 Raster Scanner Dimensions

Mechanical**MS-7100:**

Length: 5.33 in./13.54 cm Width: 5.56 in./14.12 cm
 Height: 3.06 in./7.77 cm Weight: approx. 3 lbs./1.36 kg

MS-7180:

Length: 8.72 in./22.15 cm Width: 5.56 in./14.12 cm
 Height: 4.05 in./10.3 cm Weight: approx. 4 lbs./1.8 kg

Light Source

Type: laser diode

Output: visible, 670 nm nominal

Operating life: 10,000 hrs. min @ 122° F (50° C)

Scanning Parameters

Type: rotating polygon mirror

Rate: 600 to 1000 scans/second (standard)

Scan width angle: 40°; Pitch: ±50°; Skew: ±40°

Communications

RS-232, 422, and 485; ASCII 7 or 8 data bits, 1 or 2 stop bits,
 600 to 38.4K baud, selectable parity

Code Types

Code 39, Codabar, Interleaved 2 of 5, UPC/EAN, Code 128,
 Code 49 optional

User Outputs

Beeper, 3 relay pulse outputs, match code, two status LEDs

Protocols

Point-to-point, XON/XOFF, RTS/CTS, RTS/CTS with
 XON/XOFF, polling mode D, user defined, multidrop, and
 user defined multidrop

Environmental

Housing: Dust tight case, NEMA12

Operating temp.: 32° to 122° F (0° to 50° C)

Storage temp.: -51° to 158° F (-46° to 70° C)

Humidity: up to 90% (non-condensing)

Ambient light immunity: 450 foot candles (indoor: fluorescent,
 incandescent, mercury and sodium vapor); 2000 foot candles
 (outdoors: soft)

Electrical

Power supply requirement.: Input 10 to 28 VDC unregulated @
 9W max. with less than 1V p-p ripple

Status Lights

| LED | Light | Status |
|------------|----------------------------|--------------------------|
| Power LED | Green | On power-on |
| Status LED | None (off) | Read cycle (no decode) |
| | Green | Read cycle (good decode) |
| | Amber | Ready (good decode) |
| | Red | Ready (no read) |
| | Error pattern ^a | Error |

^a Error pattern consists of alternating RED-Normal -GREEN-Normal- NONE-Normal (where "normal" is the background read/ready condition: none, amber, red, or green)

Options

Low density, high density, and ultra high density host connections

I/O Connectors

Trigger connections:

| | |
|---|---|
| 1 | Power ground |
| 2 | Supply +12 VDC (out) @ 50 mA |
| 3 | Optional power input to the scanner (10 to 28 VDC unreg.) |
| 4 | Trigger input from the object detector |
| 5 | Power ground |
| 6 | Optional power input to the scanner (10 to 28 VDC unreg.) |
| 7 | Relay contact 1, (200 mA or 4 VA) |
| 8 | Relay-output #1 (source or sink 4 mA) |
| 9 | Relay contact 2 (200 mA or 4 VA) |

Power connections:

| | |
|---|--|
| 1 | Power ground |
| 2 | Aux. transmit (RS-232) |
| 3 | Power input 10 to 28 VDC unreg. @ 9W max. with less than 1V p-p ripple |
| 4 | Aux. receive data (RS-232) |
| 5 | Chassis ground |
| 6 | Power input 10 to 28 VDC unreg. @ 9W max. with less than 1V p-p ripple |
| 7 | Relay contact 1, (200 mA or 4 VA) |
| 8 | Relay-output #1 (source or sink 4 mA) |
| 9 | Relay contact 2 (200 mA or 4 VA) |

Appendices

Host Connections

| | | | |
|----|---------------------------------------|----|--------------------------------------|
| 1 | Chassis ground | 15 | TXD+ (RS-422/RS-485) |
| 2 | Transmit data (RS-232) | 16 | TXD- (RS-422/RS-485) |
| 3 | Receive data (RS-232) | 17 | Reserved |
| 4 | Request to send (RS-232) | 18 | Aux transmit data (RS-232) |
| 5 | Clear to send (RS-232) | 19 | Aux receive data (RS-232) |
| 6 | Relay-output #1 (source or sink 4 mA) | 20 | Power ground |
| 7 | Signal ground (RS-232) | 21 | RXD + (RS-422/RS-485) |
| 8 | Noread | 22 | RXD - (RS-422/RS-485) |
| 9 | +5 VDC out (100 mA max.) | 23 | Reserved |
| 10 | Trigger in. (0 VDC to +24 VDC) | 24 | Reserved |
| 11 | +12 VDC out (50 mA max.) @ 50 mA | 25 | TTL--output #2 (source or sink 4 mA) |
| 12 | -12 VDC out (20 mA max.) @ 50 mA | 26 | Default config. |
| 13 | Signal ground | 27 | New master |
| 14 | Pwr In. (10 to 28 VDC unreg.) | 28 | CPU master reset |

Optical Characteristics

Operating range: 2 to 55 inches (5.1 to 140 cm) depending on density option, label type and size

Label contrast: 25% min. absorption dark to light differential at 670 nm

| Narrow-Bar-Width | Read Range | Maximum Scan Width |
|--------------------|------------------------------|--------------------|
| Low Density | | |
| .020" | 6" to 23" (15.2 to 58.4 cm) | 13" (33.0 cm) |
| .030" | 4" to 34" (10.2 to 86.4 cm) | 18" (45.7 cm) |
| .040" | 10" to 44" (25.4 to 112 cm) | 25" (63.5 cm) |
| .050" | 10" to 55" (25.4 to 140 cm) | 34" (86.4 cm) |
| High Density | | |
| .010" | 6" to 11" (15.2 to 27.9 cm) | 7.5" (19.1 cm) |
| .015" | 5" to 16" (12.7 to 40.6 cm) | 10.5" (26.7 cm) |
| .020" | 3" to 16" (7.6 to 40.6 cm) | 10.5" (26.7 cm) |
| .030" | 4" to 20" (10.2 to 50.8 cm) | 13.5" (34.3 cm) |
| .040" | 4" to 20" (10.2 to 50.8 cm) | 13.5" (34.3 cm) |
| Ultra High Density | | |
| .005" | 2" to 4.25" (5.1 to 10.8 cm) | 3.25" (8.3 cm) |
| .0075" | 2" to 5" (5.1 to 12.7 cm) | 3.75" (9.5 cm) |

Note: See [Figure 1-1, "MS-7100/7180 Ranges and Scan Widths,"](#) on page 1-4.

Appendix B — ASCII Table

Table A-1 ASCII Table with Control Characters

| Dec | Hex | Mne | Ctrl | Dec | Hex | Ch | <i>Dec</i> | Hex | Ch | Dec | Hex | Ch |
|-----|-----|-----|------|-----|-----|----|------------|-----|----|-----|-----|----|
| 00 | 00 | NUL | ^ | 32 | 20 | SP | 64 | 40 | @ | 96 | 60 | ` |
| 01 | 01 | SOH | ^A | 33 | 21 | ! | 65 | 41 | A | 97 | 61 | a |
| 02 | 02 | STX | ^B | 34 | 22 | " | 66 | 42 | B | 98 | 62 | b |
| 03 | 03 | ETX | ^C | 35 | 23 | # | 67 | 43 | C | 99 | 63 | c |
| 04 | 04 | EOT | ^D | 36 | 24 | \$ | 68 | 44 | D | 100 | 64 | d |
| 05 | 05 | ENQ | ^E | 37 | 25 | % | 69 | 45 | E | 101 | 65 | e |
| 06 | 06 | ACK | ^F | 38 | 26 | & | 70 | 46 | F | 102 | 66 | f |
| 07 | 07 | BEL | ^G | 39 | 27 | ' | 71 | 47 | G | 103 | 67 | g |
| 08 | 08 | BS | ^H | 40 | 28 | (| 72 | 48 | H | 104 | 68 | h |
| 09 | 09 | HT | ^I | 41 | 29 |) | 73 | 49 | I | 105 | 69 | i |
| 10 | 0A | LF | ^J | 42 | 2A | * | 74 | 4A | J | 106 | 6A | j |
| 11 | 0B | VT | ^K | 43 | 2B | + | 75 | 4B | K | 107 | 6B | k |
| 12 | 0C | FF | ^L | 44 | 2C | , | 76 | 4C | L | 108 | 6C | l |
| 13 | 0D | CR | ^M | 45 | 2D | - | 77 | 4D | M | 109 | 6D | m |
| 14 | 0E | SO | ^N | 46 | 2E | . | 78 | 4E | N | 110 | 6E | n |
| 15 | 0F | SI | ^O | 47 | 2F | / | 79 | 4F | O | 111 | 6F | o |
| 16 | 10 | DLE | ^P | 48 | 30 | 0 | 80 | 50 | P | 112 | 70 | p |
| 17 | 11 | DC1 | ^Q | 49 | 31 | 1 | 81 | 51 | Q | 113 | 71 | q |
| 18 | 12 | DC2 | ^R | 50 | 32 | 2 | 82 | 52 | R | 114 | 72 | r |
| 19 | 13 | DC3 | ^S | 51 | 33 | 3 | 83 | 53 | S | 115 | 73 | s |
| 20 | 14 | DC4 | ^T | 52 | 34 | 4 | 84 | 54 | T | 116 | 74 | t |
| 21 | 15 | NAK | ^U | 53 | 35 | 5 | 85 | 55 | U | 117 | 75 | u |
| 22 | 16 | SYN | ^V | 54 | 36 | 6 | 86 | 56 | V | 118 | 76 | v |
| 23 | 17 | ETB | ^W | 55 | 37 | 7 | 87 | 57 | W | 119 | 77 | w |
| 24 | 18 | CAN | ^X | 56 | 38 | 8 | 88 | 58 | X | 120 | 78 | x |
| 25 | 19 | EM | ^Y | 57 | 39 | 9 | 89 | 59 | Y | 121 | 79 | y |
| 26 | 1A | SUB | ^Z | 58 | 3A | : | 90 | 5A | Z | 122 | 7A | z |
| 27 | 1B | ESC | ^[| 59 | 3B | ; | 91 | 5B | [| 123 | 7B | { |
| 28 | 1C | FS | ^\ | 60 | 3C | < | 92 | 5C | \ | 124 | 7C | |
| 29 | 1D | GS | ^] | 61 | 3D | = | 93 | 5D |] | 125 | 7D | } |
| 30 | 1E | RS | ^^ | 62 | 3E | > | 94 | 5E | ^ | 126 | 7E | ~ |
| 31 | 1F | US | ^_ | 63 | 3F | ? | 95 | 5F | _ | 127 | 7F | Δ |

Appendices

Appendix C — Orientation

Label Orientation

If the bar code label bars are parallel to the direction of travel, as shown in figure A-3, the label is said to be in a *ladder* orientation; if the bars are perpendicular with the direction of travel, the label is said to be in a *picket fence* orientation (figure A-4).

Ladder Orientation

In general, depending on label size and speed, ladder orientation is preferable because different portions of the label are scanned as the label goes by. In addition, label placement is not as critical. As shown in figure A-3, a label can be successfully read if fully placed (including quiet zones) anywhere within the readable portion of the scan line.

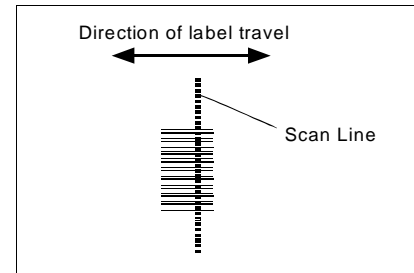

Figure A-3 Ladder Orientation

Picket Fence Orientation

Unlike ladder, picket fence allows only a small portion of the entire label to be scanned. As a result, labels must be of good quality since even slight label imperfections such as extraneous ink, voids, etc., can cause misreads or non-reads.

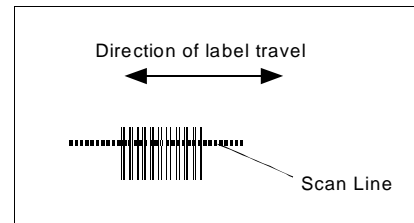

Figure A-4 Picket Fence Orientation

One advantage of the picket fence over the ladder orientation is in the area of label speed. In ladder mode, the label travel distance is the height of the bar code; in picket fence mode, the label can be read while it travels the full distance of the scan width.

Note: *Either ladder or picket fence can be rotated without losing its orientation, provided that the label's direction of travel does not change in relation to the scan line.*

Angled Picket Fence Orientation

The problems associated with picket fence can be minimized by slightly tilting the scan line (figure A-5). This allows a larger portion of the label to be scanned and increases the label placement area by “simulating” the ladder orientation. This of course is impractical with a short bar code height.

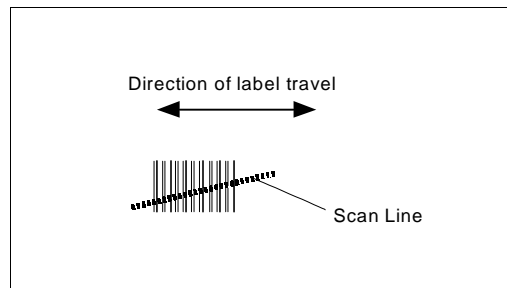

Figure A-5 Angled Picket Fence Orientation

Angled picket fence is recommended only where the bar code is reasonably tall and the label speed is not too fast in relation to the scan field width, since angling the label will reduce the number of scans on the label

Object Detector Orientation

In a typical operation, a scanner will “look” for bar code data only during a triggered read cycle. A read cycle is initiated by a “trigger” which can be in the form of a serial command from the host (internal trigger) or a signal from an object detector (external trigger).

When an object detector is used, it is set up so that its beam will bounce off the approaching object and the resulting pulse will be sent to the scanner to begin the read cycle. Typically, a detector is positioned so that it will detect the presence of an object before the object’s label can be scanned by the scanner.

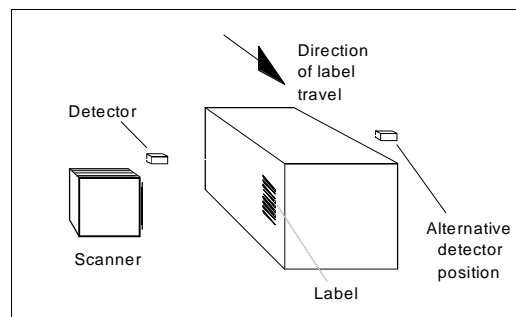

Figure A-6 Detector Side Orientation

An object detector is mounted in almost any position relative to the object as long as (1) the object passes within range of the detector and (2) direct or reflected light from the detector does not interfere with the scanner reception.

Appendices

As the item continues to move down the line, its label moves into the scanner beam and is read by the scanner.

Figure A-7 shows a picket fence label being scanned with the detector and scanner at right angles to each other.

Figure A-6 shows a label in the ladder direction with the object detector on the same side as the scanner, but positioned so as not to cause interference.

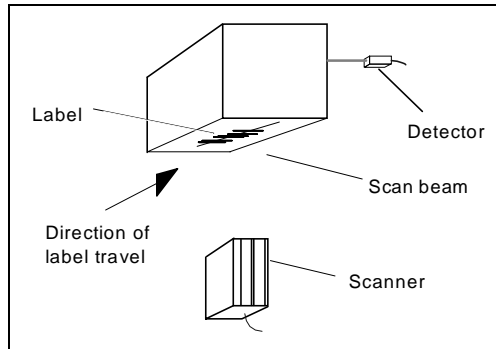

Figure A-7 Detector Right-Angle Orientation

- **Scan Rate (SR)** is the number of scans per second (sps) that a given scanner is capable of emitting.
- **Scan Width (SW)** (picket fence formula only) is the width across the scan beam, at a given distance from the scanner, in which a label can be read.
- **Label Speed (LS)** is the distance per second that a label moves as it travels through the scan lines.
- **Label Length (LL)** (picket fence formula only) is the length of the longest printed label to be read plus the length of the quiet zones (figure A-8).
- **Label Height (LH)** (ladder formula only) is a measurement of the height of individual bars (figure A-8).
- **Raster Height (RH)** is the distance between the extremities of the scan lines as shown in the raster image in figure A-9. Raster height is generally dictated by the application (range and label placement). Other factors being equal, the greater the raster height, the fewer scan lines available for given label.

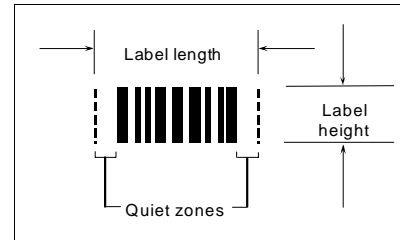

Figure A-8 Label Dimension

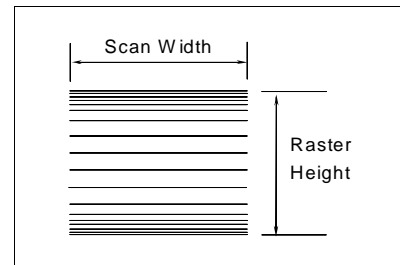

Figure A-9 Raster Image

Appendix D — Ground and Shield Considerations

Proper grounding is necessary for operator safety, noise reduction, and the protection of equipment from voltage transients. Buildings—including any steelwork, all circuits, and all junction boxes—must be grounded directly to an earth ground in compliance with local and national electrical codes.

RS-232 signals have a common signal ground (pin 7 of the 28-pin connector). Pin 7 is normally connected to pin 1 (chassis ground) in the scanner; however, under certain conditions (e.g., when potential differences exist between power outlet grounds) signal and chassis grounds can be isolated from each other inside the scanner by Microscan technicians.

Any data line, as necessary, can be shielded. If used, shielding should be isolated from the scanner and grounded only to the host earth ground.

Noise Interference

Noise interference can be minimized if cabling subject to noise interference is twisted and/or shielded or encased in grounded conduit, and the conduit or shielding (“drain” line) is grounded only to earth ground at the host, as shown in figure A-10. You might need to examine and if necessary cut the shielding connection at or near the scanner cable connector.

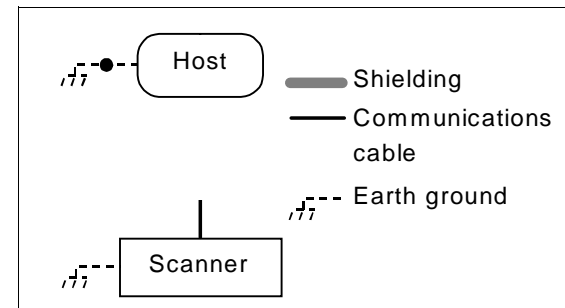

Figure A-10 Grounding Diagram, Scanner-Host

Ground Loops

Ground loops, signal degradation due to different ground potentials in communicating devices, can be eliminated or minimized by ensuring that the host, scanner, and their power supplies are connected to a common earth ground.

Appendix E — Defaulting the Scanner

Defaulting the scanner resets the scanner configuration parameters to their original default values and recalls factory calibration settings.

Defaulting is necessary if:

- You wish to quickly restore default settings to the configuration program after making some temporary changes.¹
- You wish to restore factory calibration settings.²
- Communications between the scanner and another device are interrupted because of incompatible settings (for example, a terminal is set to communicate at 9600 baud, but the scanner is configured at 38.4K baud).
- The scanner has been assigned a polling address and you wish to access the scanner's menu.

Note: Access to the configuration menus of a scanner that is in a polled mode can be forced by sending a <D> command from an auxiliary terminal via the auxiliary RS-232 port.

You can default the scanner by shorting pins 7 and 26 together. This can be done with a mating connector that is made up with a jumper between pins 7 and 26, or by using a wire to short those same pins.

Caution: Be certain that the correct pins are shorted. Shorting the wrong pins can cause serious damage to the unit.

If no mating connector is available:

1. Turn power to the scanner ON.
2. Locate pins 7 and 26 on the host connector (figure A-11) and mark with a pen.
3. Using a small length of 18 to 26 gauge wire, momentarily short pins 7 and 26 by inserting mating connector or wire. Listen for a series of short beeps.
4. Within 3 seconds, short pins 7 and 26 again. A longer beep should be heard. If not, repeat the process.

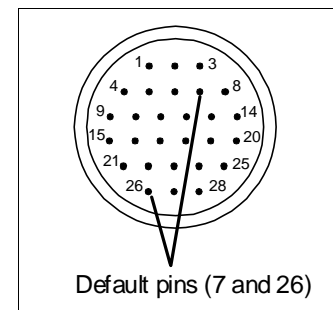

Figure A-11 Host Connector
Default Pins

1. There are no menu options or host commands for resetting the configuration program.
2. Factory calibration settings can also be recalled from within the Calibration Setup menu (see [Chapter 4, "Calibration"](#)).

Appendix F — Troubleshooting

The MS-7100/7180 scanner when used correctly should produce good reads. If not, table A-2 lists some of the more common problems associated with setting up and using the scanner. If you are unable to locate or correct the problem, call your Microscan representative.

WARNING
*Do not look directly into laser aperture.
 Laser light can be hazardous to your eyes.*

Table A-2 Troubleshooting

| Problem | Possible Cause | Solution |
|--|---|---|
| Menus do not display when configuration command is sent | Host cable defective or not wired properly | Check cable connections and wiring. (See page 1-8.) |
| | Wrong configuration command (or lower case d) entered | Verify that a <D> serial command (with an upper case D) is being entered. |
| | Scanner configuration settings do not match host's | Reset scanner to default and/or match host settings with scanner's. |
| Getting only "hieroglyphics" or unintelligible code | Host and scanner baud rates or parity not matched | Check baud rates and parity and change to match host's settings. |
| Menus display but getting 0% read rate when in read rate test (<C>) or Calibration Setup (<t>) | Wrong label type (different label type being scanned than that enabled in firmware) | Check label configuration settings to be certain that they match the label type being scanned. If label type is in doubt, enable Auto-discriminate All Codes (<P> command). Ensure that fixed length and check sums, if enabled, are set correctly. |
| | Incorrect label range or label too long to be totally covered by scan beam. | See range data in Step 2, "Verify Read Range," on page 1-3. Reposition label and check the read rate (<t> or <C> commands). |
| | Poor label quality | Try a label that is known to be readable. |
| | Excessive ambient light, sunlight, or strobes | Shield the bar code and/or scan head to verify that excessive light is not the problem. |
| | Object detector or another scanner interfering with reads | Remedy by remounting, eliminating interference, or shielding. Many object detectors emit pulsed infrared signals that can seriously degrade the read rate if they shine into the scanner or onto the bar code label when it is being read. |

Appendices

| Problem | Possible Cause | Solution |
|--|---|---|
| Getting low percentage read rates during read rate test (<C>) or Calibration Setup (<t>) | Poor label, range, placement, etc. | See "Menus display..." problem on page A-11 . Do Step 9, "Test and Autocalibrate," on page 1-15 and/or Step 10, "Adjust Other Scanning Parameters," on page 1-16 . |
| Read rate okay but getting only noread messages in triggered mode | Scanner not triggered when in external mode. | Ensure trigger device is operating properly. Do Read Rate Test <C>. If it reads successfully, the problem is triggering. |
| | Scanner not triggered when in serial mode. | Ensure that correct serial trigger character is entered with start/stop characters (a left angle bracket < (unless redefined) and a right angle bracket >). |
| | Label misaligned or reflecting direct laser light | Ensure the label is not excessively skewed, tilted, or otherwise disoriented. Ensure the bar code is in the scan line when it is supposed to be. Ensure that the bar code is pitched or skewed slightly so as to avoid specular reflection. |
| | Triggering/timeout out of sync | Review triggering and timing. (See "Operations Menu," on page 2-12 .) |
| | Object detector or another scanner interfering with reads | Remedy by remounting, eliminating interference, or shielding. Many object detectors emit pulsed infrared signals that can seriously degrade the read rate if they shine into the scanner or onto the bar code label when it is being read. |
| | Window dirty or obstructed | Clean or remove obstruction. |
| Previous label read, but subsequent label will not read | Scanner configured in Continuous Read 1 mode | Scan a label that contains different data than that of one being read. |
| | Scanner in polled mode | Check communications protocol. |
| Scanner not communicating in polled mode. | LRC disabled | Enable LRC. |
| | Improper configuration | Check communications parameters (through Aux port or by defaulting unit and resetting). |
| | Faulty or improper cabling or ground | See Step 6, "Attach Cabling," on page 1-8 and in particular, "Ground and Shield Considerations," on page A-9 for cabling information, or if applicable, refer to multidrop manual. |

| Problem | Possible Cause | Solution |
|--|--|---|
| Scanner not entering read cycle (trigger not working) | Proper trigger levels not enabled | Ensure that the trigger pulse and the trigger polarity settings are correct. |
| | Trigger circuit not correctly wired | Ensure that the trigger circuit wiring meets the scanner requirements. (See Step 6, "Attach Cabling," on page 1-8.) |
| | Object detector inoperative | Check detector range and sensitivity. Try a detector that is known to be good. |
| Scanner not reading during the read cycle | Object detector not positioned properly | Ensure read cycle is active during the time the label is in the scan line. |
| | End of Read Cycle not properly defined for the application | Ensure that the proper End of Read Cycle is defined in scanner configuration. |
| "Bad Format" message | Illegal format for a UCC/EAN-128 label has been detected in Ap. Rec. format. | Correct label. |

Appendix G — Bar Code Symbology

Before choosing a bar code symbol, consider:¹

- the type of information to be scanned (numeric only, alphanumeric)
- the length of the messages to be encoded
- how and where labels are to be applied
- label printer capabilities
- scan speed
- beam width
- the space available on the object to be identified
- host software limitations
- range of the scanner
- the speed of the conveyor

Microscan standard scanner firmware supports the following five bar code symbologies. (Firmware can also be custom ordered to support other symbologies.)

Code 39. An alphanumeric code with unique start/stop code patterns, composed of 9 black and white elements per character, 3 of which are always wide. Considered the de facto standard for non-retail symbology.

Codabar. A 16-character set (0 through 9, and the characters \$, :, /, ., +, and -) with start/stop codes and 18 different bar widths. It is commonly used in libraries, photo finishing, and air parcel express applications.

I 2 of 5. Interleaved 2 of 5 is a high-density, continuous numeric symbology used mainly in the distribution industry. I 2 of 5 encodes two digits: one in the bars, and one in the spaces. (A check digit is highly recommended.)

UPC and EAN. UPC (Universal Product Code) is a fixed length numeric, continuous symbology used in the supermarket and retail industry. The European Article Numbering system (EAN) is a well-known variation of UPC. Both UPC and EAN can have 2 or 5 digit supplemental bar code data following the normal code.

Code 128. A very high density alphanumeric symbology. Will encode all 128 ASCII characters, it is continuous, has variable length, and uses multiple element widths measured edge to edge. It is widely used in the non-food distribution industry and shipping containers.

UCC/EAN-128. A subset of Code 128. Breaks code into data fields separated by application identifiers that define data type and length.

1. For further information about symbology, see *The Bar Code Book*, by Roger C. Palmer, Helmers Publishing, Inc., 1989.

Appendix H — Interface Standards

Interface Standards, established by the Electronic Industries Association (EIA), specify such things as the signaling voltage levels, maximum cable lengths, and number of drivers. With Microscan devices, selection of interface is made by pin assignment (see Appendix A, “[Scanner Specifications](#),” on page A-2) and, in the case of the host communications, by software switching between RS-232 and RS-422. Microscan devices use RS-232, RS-422, and RS-485 multidrop.

RS-232

RS-232 defines an interface between two devices such as, for example, the scanner and host. It differs from the other interfaces by dedicating individual pins to specific functions and by requiring both devices to share a common ground line (pin 4). Since both device chassis are connected to a common ground, a ground loop potential and the possibility of noise interference exists. Therefore cable lengths are limited to a maximum of 50 feet (19.7 m). Despite being the most limited, this interface is used frequently because of the large installed base of RS-232 equipment.

RS-422

RS-422, unlike RS-232, measures signals differentially that is, the receiver looks at the potentials between the two receive (or transmit) wires rather than the potential between signal and ground. As a result, cables, if shielded, can be up to 4000 feet (1575 m) in length. Like RS-232, RS-422 communication is designed for only two devices on a single line. It can be used wherever RS-232 is used.

RS-485

RS-485, like RS-422, can transmit up to 4000 feet (1575 m) using differential voltages but unlike RS-422, its transmitters are turned off until a request for data is received from the host. RS-485 is used exclusively in Multidrop protocol.

Note: See “[Protocol](#),” on page 2-6 for additional information on standards.

Appendix I — Auxiliary Monitor

An auxiliary monitor, connected to the scanner can:

1. Echo data from the scanner or host.
2. Send data to the host.
3. Access and make changes to the scanner's configuration menus.

The monitor can be configured to operate in one of three modes:

- Transparent
- Non-Buffered Full Duplex
- Non-Buffered Half Duplex

Note: *Transparent can be used with all protocols. Full Duplex and Half Duplex operations can be used with any protocol except polled protocols (Polling Mode D, Multidrop, User Defined, and User Defined Multidrop).*

Transparent Mode

Used to batch data from the monitor to the host. The scanner buffers data from the monitor and displays the keyed data on the monitor. The scanner transmits monitor data to the host when a label is scanned or a carriage return is entered from the monitor.

Data Initiated from the Monitor

- Monitor data is passed through to the host whenever a return key is pressed at the monitor or whenever bar code data is sent. If sent with bar code data, it is processed on a first-in/first-out basis.
- Monitor data to the host is always sent with a preamble and a postamble.
- If the MS-7100/7180 is in a polled mode to the host, monitor data will still pass through.
- The <D> and <t> commands are the only commands accepted by the scanner from the monitor. All other commands will pass through to the host.

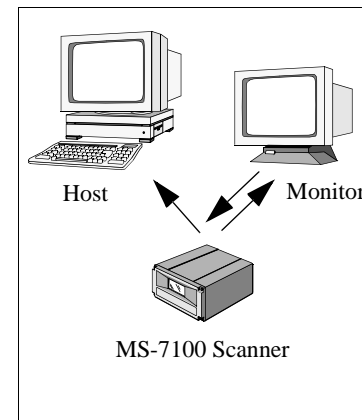

Data initiated from the Scanner

- Transmission to the monitor occurs immediately upon a good read.
- Scan data to the monitor does not include a preamble or a postamble.
- Communications with the monitor is always in Point-to-Point protocol, even if the host is in a polled protocol mode.

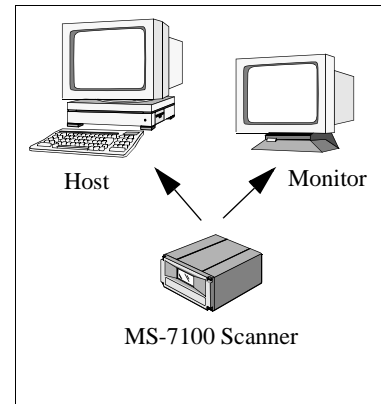

Data initiated from the Host

- In polled mode, data echoed from the host to the monitor must be in the format <B ____> (e.g., to send the word “LUNCH” to the monitor, it must be sent in the format <BLUNCH>). In unpolled mode, all host data is echoed to the monitor.

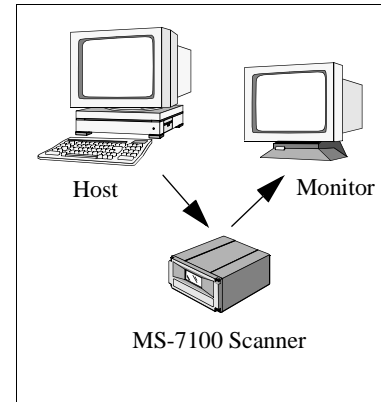

Half Duplex Mode

In half duplex mode all monitor data and bar code data is sent directly to the host. Bar code data is displayed on the monitor screen at the same time the data is sent to the host.

Data initiated from the Monitor

- Monitor data to the host is ignored if the scanner is in a polled mode.
- Monitor data or scanned data is sent to the host whenever it is received.
- Monitor data is not echoed.
- Monitor data to the host is always sent without a preamble or a postamble.
- <D> and <t> commands are the only commands that is accepted by the scanner from the monitor. All other commands are passed through to the host.

Data initiated from the Scanner

- Scan data is transmitted to the monitor at the same time it is transmitted to the host.
- Data transmission conforms with all parameters specified in the configuration menu (e.g., Preamble, Postamble, End of Read Cycle).

Data is initiated from the Host

- In polled mode, data echoed from the host to the monitor must be in the format <B____> (i.e.: to send the word "LUNCH" to the terminal, it must be sent in the format <BLUNCH>).
- In unpolled mode, all host data is echoed to the monitor.

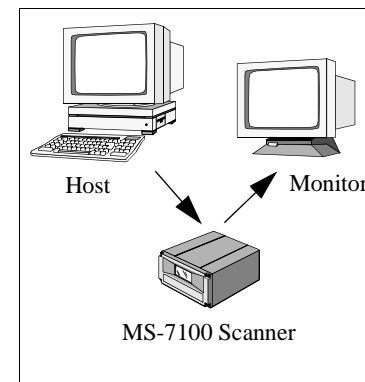
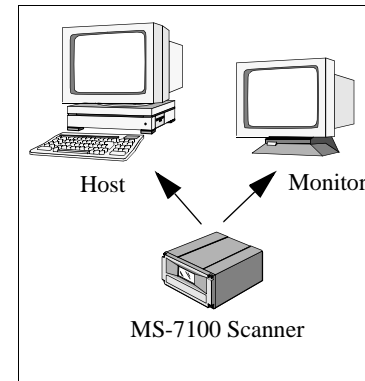
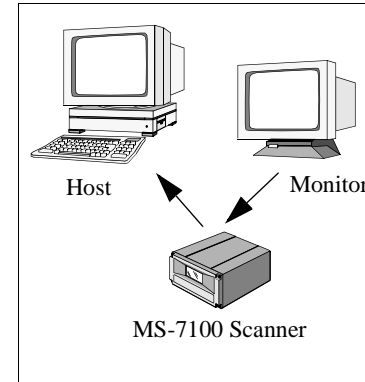

Full Duplex Mode

In full duplex mode, all monitor data and bar code data is sent directly to the host. Bar code data is not displayed on the monitor screen.

Data initiated from the Monitor

- Monitor data is passed directly through to the host whenever it is received by the scanner, unless the scanner is in a polled mode, in which case the data will be ignored.
- Monitor data is not echoed.
- Monitor data to the host will not have a preamble or a postamble.
- A <D> and <t> commands are the only commands accepted by the scanner from the monitor. All other commands will pass through to the host.

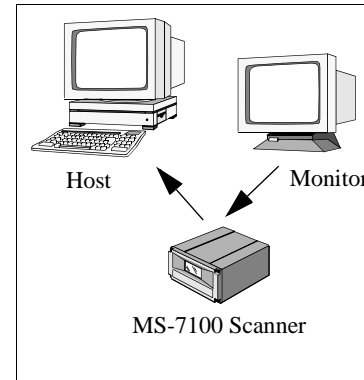

Data initiated from the Scanner

- Scan data is not sent to the monitor.

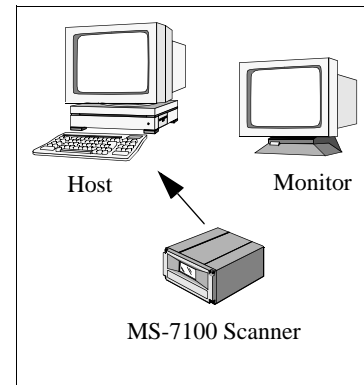

Data initiated from the Host

- In polled mode, data echoed from the host to the monitor must be in the format <B____> (i.e., to send the word "LUNCH" to the terminal, it must be sent in the format <BLUNCH>).
- In unpolled mode, all host data is echoed to the monitor.

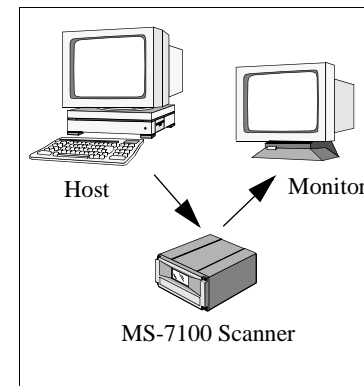

Daisy Chain Mode

In a daisy chain application, a primary scanner is linked directly to the host and succeeding scanners are linked in tandem. Data from succeeding scanners is transmitted directly to the host as if it were coming from the primary scanner.

The conditions for a daisy chain application are as follows:

1. The primary scanner's trigger can be serial or external; the succeeding scanners' triggers must be set to serial.
2. Each succeeding scanner in the daisy chain must be connected to the aux. port of its preceding scanner.
3. Each succeeding scanner in the daisy chain should be set to send its data less than 20 ms before its preceding scanner. For example, if the primary scanner is set to timeout in 100 ms, the first succeeding scanner can be set to 90 ms, the next to 80 ms, etc.
4. Postamble must be set to CR (^M) and enabled.
5. Succeeding scanners must have noread messages disabled.
6. Multilabel separator characters and the number of labels must match in all scanners in the daisy chain.

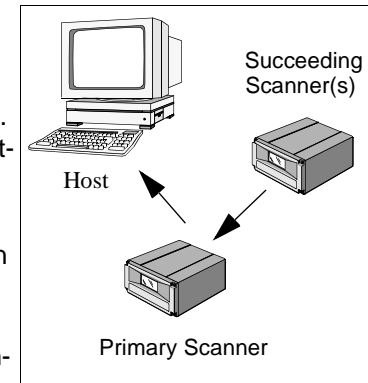

Daisy Chain Description

Just before sending a noread message, the primary scanner checks its auxiliary port for data. It waits a maximum of 20 ms. If no character is received in 20 ms, it sends a noread message to the host. After each character received, it waits up to 20 ms for the next character or a CR. If a complete message is received, it is sent to the host instead of the noread message.

Daisy-chained scanners can send a series of labels by enabling Multilabel and a common multilabel separator. If a scanner does not receive the expected number of labels, noread messages are appended to the data string to make up the difference between the number of labels enabled in Multilabel (Number of Labels) and the number of labels read.

For example, a primary and two succeeding scanners have Number of Labels set to 3 and Multilabel Separator defined as %. If the primary and the first succeeding scanner do not find labels, but the next scanner registers a good read, the transmitted results would be: *label data % noread % noread*.

Appendix J — Multidrop Communications

This appendix describes the rules for setting up a concentrator or controller to communicate with a scanner in standard Multidrop protocol, as presented in [“Protocol,” on page 2-6](#).

Figure A-12 shows a typical Multidrop network in which 1 to 50 scanners can communicate with a host via an intermediary device, a concentrator or a controller.

Multidrop Addresses

- No two scanners in the Multidrop Network can have the same address.
- Each scanner in the network must have an address (from 01 to 50) assigned in its configuration program.

Each address has its own separate poll and select address (from 1C to 7F hex as shown in [table A-3 on page A-24](#)).

For example, during a polling sequence, scanner 03 expects a 20 hex (“SP” ASCII poll character) from the concentrator. And during a select command, it looks for a select value 21 hex (“!” ASCII select character).

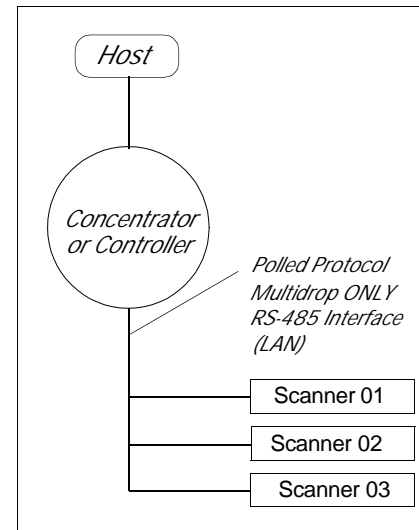

Figure A-12 Typical Multidrop Network

Polling Sequence

Data that is transmitted to the host (bar code data, noread messages, counters, etc.) via concentrators is solicited by poll requests from the host.

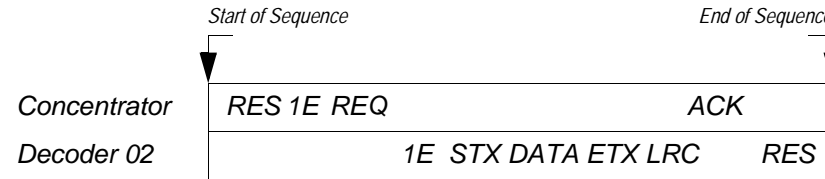

Figure A-13 Polling Sequence

The polling sequence example in figure A-13 begins with a RES (reset) from the concentrator followed by poll address 1E (ASCII hex value for scanner 02) and a REQ (request). The scanner responds by first transmitting its own address, 1E, followed by a STX (start of text) character, and then the data. Next it transmits an ETX (end of text) character and an LRC (longitudinal redundancy check) character.

If the concentrator (or controller) receives the data from the scanner and is able to validate it with an LRC calculation, it responds with an ACK (acknowledgment). If the scanner in turn receives the ACK, the scanner ends this successful exchange with a RES (reset).

Polling Reset

- If the scanner has no information, it responds to a poll request by transmitting a RES (reset).
- If the scanner receives a NAK instead of the ACK after transmitting its data string, it will re-attempt to transmit the data string up to three times. If the scanner still does not receive an ACK, it will transmit a RES (reset) and discard the data in its buffers.
- If the scanner transmits data to the concentrator and the concentrator responds with an ACK or NAK, but the scanner doesn't receive the concentrator's response, the scanner will timeout and transmit a REQ to the concentrator and request another response. If after three retries (the number of times it transmits a REQ to the concentrator) the scanner receives no response, it ends the transmission with a RES (reset).

Select Sequence

Unlike poll requests, select commands always originate from the host and consist of serial configuration or operation commands to devices that are configured in Multidrop. The scanner complies with the command when it is polled during the cycle.

Figure A-14 is an example of a select sequence

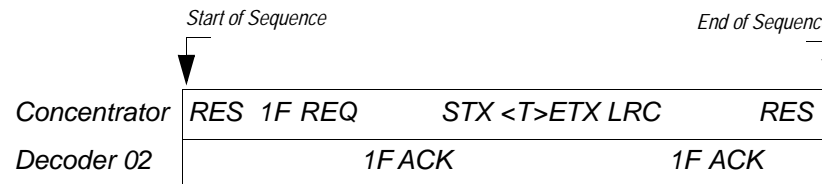

Figure A-14 Select Sequence

A RES (reset) is the first command in the select sequence. The 1F hex is the select address associated with scanner's 02 address (see [table A-3 on page A-24](#)). It is followed by a REQ (request). The scanner responds with its own select address, 1F hex, and an ACK (acknowledge). The concentrator then transmits an STX (start of text), the data (in this case a <T>), an ETX (end of text), and an LRC character.

The scanner replies by transmitting its own address, followed by an ACK, acknowledging receipt of the command. Upon receipt of an ACK, the concentrator concludes the successful exchange with a RES.

In the example above, the scanner only acknowledges a trigger counter request from the concentrator. It does not respond to the trigger counter request until a subsequent poll. For example, if the scanner's trigger count was 12 at the time the trigger counter request was received, on a subsequent poll it would transmit 02T/00012. (The 02 at the beginning of the string is the scanner's address.)

Select Reset

- If the scanner receives bad data from the concentrator, it transmits a SEL (its select address) and a NAK to the concentrator. The concentrator retransmits the data up to three times. The concentrator will end the sequence with a RES (reset) if no ACK is received.¹

1. For additional information on Multidrop, see the MS-5000 Multidrop Concentrator User's Manual.

Appendices

Table A-3 Multidrop Address Characters

| Multidrop Address | Poll Character | | Select Character | | Multidrop Address | Poll Character | | Select Character | |
|-------------------|----------------|-----|------------------|-----|-------------------|----------------|-----|------------------|-----|
| | ASCII | HEX | ASCII | HEX | | ASCII | HEX | ASCII | HEX |
| 01 | ^\ | 1C | ^] | 1D | 26 | N | 4E | O | 4F |
| 02 | ^^ | 1E | ^- | 1F | 27 | P | 50 | Q | 51 |
| 03 | SP | 20 | ! | 21 | 28 | R | 52 | S | 53 |
| 04 | " | 22 | # | 23 | 29 | T | 54 | U | 55 |
| 05 | \$ | 24 | % | 25 | 30 | V | 56 | W | 57 |
| 06 | & | 26 | ' | 27 | 31 | X | 58 | Y | 59 |
| 07 | (| 28 |) | 29 | 32 | Z | 5A | [| 5B |
| 08 | * | 2A | + | 2B | 33 | \ | 5C |] | 5D |
| 09 | , | 2C | - | 2D | 34 | ^ | 5E | _ | 5F |
| 10 | . | 2E | / | 2F | 35 | ` | 60 | a | 61 |
| 11 | 0 | 30 | 1 | 31 | 36 | b | 62 | c | 63 |
| 12 | 2 | 32 | 3 | 33 | 37 | d | 64 | e | 65 |
| 13 | 4 | 34 | 5 | 35 | 38 | f | 66 | g | 67 |
| 14 | 6 | 36 | 7 | 37 | 39 | h | 68 | i | 69 |
| 15 | 8 | 38 | 9 | 39 | 40 | j | 6A | k | 6B |
| 16 | : | 3A | ; | 3B | 41 | l | 6C | m | 6D |
| 17 | < | 3C | = | 3D | 42 | n | 6E | o | 6F |
| 18 | > | 3E | ? | 3F | 43 | p | 70 | q | 71 |
| 19 | @ | 40 | A | 41 | 44 | r | 72 | s | 73 |
| 20 | B | 42 | C | 43 | 45 | t | 74 | u | 75 |
| 21 | D | 44 | E | 45 | 46 | v | 76 | w | 77 |
| 22 | F | 46 | G | 47 | 47 | x | 78 | y | 79 |
| 23 | H | 48 | I | 49 | 48 | z | 7A | { | 7B |
| 24 | J | 4A | K | 4B | 49 | | 7C | } | 7D |
| 25 | L | 4C | M | 4D | 50 | ~ | 7E | Δ | 7F |

Appendix K — Glossary of Terms

Application Identifier. Prefix of two to four digits that defines the type and length of data fields in UCC/EAN-128 code.

Autocalibration. Automatic calibration of gain and tracking settings to obtain optimum read rate.

Autodiscriminate. The ability to decode several different bar code symbolologies without changing configuration.

AWG. Abbreviation for American Wire Gauge. This is a standard measuring system for wire sizes, listed from 0 (biggest) to 40 (smallest). A 26 AWG is equivalent to 0.0159 in. (0.405 mm) in diameter.

Bandwidth. Range of frequencies (energy transitions) that are allowed to pass through bandpass filters during signal processing.

Bar Code. Data that has been encoded into an array of parallel bars and spaces of varying widths.

Bar Code Density. Number of characters per inch or other unit of measure.

Baud Rate. The term used to describe the number of discrete signal events per second. In RS-232 and RS-422/485 systems, baud rate is the same as bits per second (BPS).

Clock Speed. Internal device timing relative to individual bars and spaces

Code 39. An alphanumeric bar code with a character set containing a start/stop character, 10 numbers, 26 letters, 6 symbols, and a space. This code is discrete, variable length, and self-checking.

Concentrator. Intermediary multidrop device which communicates with up to 50 other devices, and relays data from those devices to the host as well as commands from the host to the devices.

Configuration. The method used to change factory default settings for operational features to match a specific application. Configuration can be done through menu selection or with serial commands.

Connector. Physical device (plug or socket) on unit or cable to provide in/out connectivity for various circuits and pins.

Counter. Memory space provided to keep track of read cycle events.

Depth of Field. The distance between the minimum and maximum range in which a scanner can read bar code labels.

EPROM. Erasable, programmable, read only memory. The EPROM stores the coded information that contains decoding algorithms and options that can be changed by the user.

End of Read Cycle. The time at which the scanner stops expecting label information to decode. This can be caused by a timeout, a trigger event, or a good read.

Focal Length. The distance measured from the scanner to the center of the depth of field, or *focal* point.

Gain. Signal parameter in testing a specific label and range. One of two components in autocalibration.

Good Match. The event occurring when a scanned label matches the master label information that is stored in the memory of the scanner.

Good Read. The event which occurs when a label's data is accurately scanned and decoded.

Intercharacter Gap. The extra space between the last element of one character and the first element of the adjacent character of a specific bar code symbol.

Label Height. Regardless of orientation, the measurement taken along the length of a label's individual bars.

Label Length. Regardless of orientation, the measurement taken across the label's bars from one end to the other, including the quiet zone.

Label Speed. The rate in inches or centimeters per second at which a label moves through the scan beam.

Ladder Label Orientation. A bar code label in which the bars are parallel to the label's direction of travel.

Match Code. The ability to compare bar code labels being scanned against a master label that is stored in the memory of the scanner.

Menu Configuration. The process of changing factory default settings via a sequence of menus displayed on a terminal monitor.

Mil. One thousandths of an inch or 0.0254 mm. In bar-coding, a measurement that identifies a bar code label by the width of its narrowest element.

Mismatch. An event that occurs when the scanned bar code label does not match the master label that is stored in the memory of the scanner.

Multidrop. A communications protocol for networking two or more scanners or other devices with a concentrator (or controller) and characterized by the use of individual device addresses and the RS-485 standard.

Narrow Bar Width. The width of the narrowest bar of a given label, expressed in thousands of an inch (or mils).

Non-volatile RAM (NOVRAM). Random Access memory that is available on power-on; that is, after power to the unit has been recycled.

Noread. A non-read. A condition that occurs when the scanner is set up to decode labels, and no labels are scanned during the read cycle.

Number of Scans Calculation. The number of times a bar code label is scanned by the scanner during one pass through the laser beam.

Object Detector. A photo electric device used to sense to presence or absence of an object.

Operational Commands. Serial commands from the host to the scanner to control current operating parameters, counters, master label operations, testing, and program management.

Oval Spot. An elongated laser beam involving custom optics that is designed to project lengthwise with the label's bars and spaces.

Padding. The insertion of zeros to make up the maximum length of a variable application identifier field.

Picket Fence Label Orientation. A bar code label in which the bars are perpendicular to the label's direction of travel.

Pitch. Label (or scanner) rotation around the center a line perpendicular to the label's bars.

Point-to-Point. A protocol consisting of a single communications event, typically used to connect a bar code reader to a terminal or host computer.

Polled Protocol. A protocol in which each scanner or other device has an assigned address which is used by the host when requesting data.

Port. Logical circuit for data entry and exit. (One or more ports may be included within a single connector.)

Protocol. The rules for communication between devices, providing a means to control the orderly flow of information between linked devices.

Quiet Zones. Specified "clear" (nonprinted) areas immediately before and after the bar code symbol. The area is usually white (for black and white bar code) and at least 10 times the width of the narrowest bar, as measured in thousands of an inch. The zones can be other than white as long as their densities remains consistent and they have the required contrast relative to the bars.

Read Cycle. A programmed period of time or condition during which the scanner will accept bar code label input.

Read Rate. The percentage of reads decoded by the scanner.

Read Range. The distances in which a label can be reliably read, as measured from the front of the scanner. See “Depth of Field.”

Relay Driver. A TTL signal sent by the scanner. The output is determined by the relay driver selection during configuration.

Scanner. A scanning device which is comprised of a scan head and a device integrated in one package.

Scan Rate. Number of scans per second that the scanner projects.

Scan Width. That portion of the scan line in which a label can be read,.

Serial Commands. On line data strings (including configuration and operations) from a host or other device to the scanner, which are always preceded by a < left angle bracket symbol (unless redefined by Command Start Character command) and followed by a > right angle bracket symbol.

Serial Configuration. Serial command specifically for changing configuration.

Skew. Label (or scanner) rotation around the center of the skew axis.

Specular Reflection. The direct, mirror-like reflection of laser light back to the scanner, causing over-light saturation.

Symbology. A set of bar code symbols, such as Code 39 or Code 128, which have special rules to define the widths and positions of bars and spaces to represent specific numeric or alphanumeric information.

Tilt. Label (or scanner) rotation around the centerline of the scan beam.

Timeout. A user-selected period of time that ends a scanner's read cycle.

Tracking. Parameter of analog-to-digital converter which affects the accuracy to the digitized signal.

Index

A

- ACK-NAK Protocol 2-8
- Angled Picket Fence
 - orientation* A-7
- Angled Picket Fence calculation 1-6
- Application Identifier
 - See also Symbology Identifier*
- Application Record Brackets
 - by menu selection* 2-29
 - by serial command* 3-14
- Application Record Padding
 - by menu selection* 2-30
 - by serial command* 3-14
- Application Record Separator
 - by menu selection* 2-29
 - by serial command* 3-14
- Approvals vii
- As Soon As Possible
 - by menu selection* 2-17
 - by serial command* 3-10
- ASCII
 - terminal communications* 1-13, 2-1
- Autocalibration 1-15, 4-2–4-4
 - by menu selection* 4-3–4-4
 - by serial command* 4-2
- Autodiscriminate All Codes 5-4
- Aux Monitor A-16–A-19
 - full duplex mode* A-19
 - half duplex mode* 2-11, A-18
 - transparent mode* 2-11, A-16
- Aux Port Parameters
 - by menu selection* 2-11
 - by serial command* 3-8

B

- Bandwidth 1-17, 4-8
- Bar Code Output
 - by menu selection* 2-12, 2-17
 - by serial command* 3-10
- Bar Code Symbology A-14
- Bar Size Measurements 4-9
- Baud Rate

- by menu selection* 2-10
 - by serial command* 3-8
- Baud Rate (host port)
 - by serial command* 3-8
- Beep on K Command
 - by menu selection* 2-35
 - by serial command* 3-17
- Beeper Status 3-15
 - by menu selection* 2-32
 - by serial command* 3-15
- Beeper Volume
 - by menu selection* 2-32
 - by serial command* 3-15
- Big Bar 4-9
- Bottom Offset in Degrees
 - by menu selection* 2-37, 2-38
 - by serial command* 3-17

C

- Cabling
 - ground loops* A-9
 - maximum distances* 1-8
 - noise interference* A-9
 - shield considerations* A-9
- Calibration 5-3
 - bandwidth* 4-8
 - bar size measurements* 4-9
 - big bar* 4-9
 - clock speed* 4-8
 - defaulting to factory settings* 4-6
 - gain* 4-7
 - motor speed* 4-6
 - saving current settings* 4-6
 - scan rate* 4-6, 4-9
 - small bar* 4-9
 - tracking* 4-8
- Calibration Setup menu 4-5
- Check Digit
 - of code 39 (menu)* 2-22, 2-24
 - of code 39 (serial)* 3-12
 - of interleaved 2 of 5 (menu)* 2-22, 2-26
- Check Digit Output
 - of code 39 (menu)* 2-22, 2-24

Index

- of interleaved 2 of 5 (menu)* 2-26
 - Checksum of EPROM (display) 5-5
 - Clock Speed 1-17, 4-8
 - Codabar
 - by menu selection* 2-25
 - by serial command* 3-12
 - definition A-14
 - operational command* 5-4
 - Code 128
 - by menu selection* 2-28
 - by serial command* 3-14
 - definition A-14
 - Code 39
 - by menu selection* 2-24
 - by serial command* 3-12
 - definition A-14
 - operational command* 5-4
 - Code Length
 - of codabar (menu)* 2-22, 2-25
 - of codabar (serial)* 3-12
 - of code 128 (menu)* 2-22, 2-28
 - of code 128 (serial)* 3-14
 - of code 39 (menu)* 2-22, 2-24
 - of code 39 (serial)* 3-12
 - Code Length #1 (1 2 of 5)
 - by menu selection* 2-22, 2-26
 - by serial command* 3-13
 - Code Length #2 (1 2 of 5)
 - by menu selection* 2-22, 2-26
 - by serial command* 3-13
 - Code Types
 - by menu selection* 2-22–2-30
 - by serial command* 3-12–3-14
 - Code Types Status Request 3-14
 - Command Start Character
 - by menu selection* 2-31, 2-35
 - by serial command* 3-16
 - Communications
 - by menu selection* 2-5–2-11
 - by serial command* 3-5, ??–3-8
 - loss of 2-4, 3-4
 - options A-3
 - Communications Terminal 2-1
 - Concentrator A-21
 - Configuration
 - general information* 1-13
 - saving menu changes for power-on* 2-4
 - saving serial changes for power-on* 5-3
 - Connectors
 - host connector* 1-9–1-10
 - power connector* 1-12
 - trigger connector* 1-11
 - Continuous Read
 - by menu selection* 2-13
 - by serial command* 3-9
 - Continuous Read 1 Output
 - by menu selection* 2-13
 - by serial command* 3-9
 - Control Character Output (Echo K)
 - by menu selection* 2-35
 - by serial command* 3-17
 - Controller A-21
- ## D
- Daisy Chain
 - by menu selection* 2-11
 - Daisy Chain Mode A-20
 - Data Bits
 - by menu selection* 2-10
 - Data Bits (aux port)
 - by menu selection* 2-11
 - by serial command* 3-8
 - Defaulting
 - procedures* A-10
 - Defaulting (calibration) 4-6
 - Delete Master Label Information 5-6
 - Depth of Field 1-3
 - Disable Laser Scanning 5-4
 - Disable Match Code 5-6
 - Display Checksum <!> 5-5
 - Display Software 5-5
 - Download Master Label Information 5-6

E

EAN

definition A-14

See also UPC/EAN

Echo Data 5-3

Echo K Command

by menu selection 2-35

by serial command 3-17

Electrical A-3

End of Read Cycle

by menu selection 2-12, 2-14, 2-17

by serial command 3-9

when to output option (menu) 2-12

when to output option (serial) 3-10

Enter Configuration Menu 5-3

Environmental A-3

External Edge

by menu selection 2-13, 2-14

by serial command 3-9

External Level

by menu selection 2-13

by serial command 3-9

External Trigger Polarity

by menu selection 2-12, 2-16

by serial command 3-9

F

Factory Settings (calibration) 4-6

Field Separator

by menu selection 2-12, 2-18

by serial command 3-11

Fixed Code Length

of codabar (menu) 2-22, 2-25

of codabar (serial) 3-12

of code 128 3-14

of code 128 (menu) 2-22, 2-28

of code 39 (menu) 2-22, 2-24

of code 39 (serial) 3-12

Full Duplex

by menu selection 2-5, 2-11

description A-19

Full Screens

by menu command 2-34

by menu selection 2-31

G

Gain 1-17, 4-7

Good Decode Reads

by menu selection 2-12, 2-18

by serial command 3-10

Good Match

by menu selection 2-31

by serial command 3-15

Relay--Output #1 2-32

TTL--Output #2 2-33

Good Read Counter 5-4

H

Half Duplex

by menu selection 2-5, 2-11

description A-18

Host Connector 1-9, A-4

Host Port Parameters

by menu selection 2-10

by serial command 3-8

Host Protocol Parameters

by menu selection 2-6

by serial command 3-5

Host Relay Driver Command 5-4

I

I 2 of 5

See Interleaved 2 of 5

I/O Connectors A-3

Installation 1-18–1-19

Intercharacter Delay

by menu selection 2-5, 2-10

by serial command 3-7

Interface Standards A-15

Interleaved 2 of 5

by menu selection 2-26

definition A-14

operational command 5-4

Index**K**

K Command Options
by menu selection 2-35

L

Label
angled picket fence orientation A-7
density 1-17
dimensions 1-17
height A-8
ladder orientation A-6
length A-8
picket fence orientation A-6
positioning 1-14
ratio 1-17
speed 1-17, A-8

Ladder
orientation A-6

Ladder calculation
7100 1-6
7180 1-7

Large Intercharacter Gap
of codabar (menu) 2-22, 2-25
of codabar (serial) 3-12
of code 39 (menu) 2-22, 2-24
of code 39 (serial) 3-12

Laser On/Off
by menu selection 2-31, 2-34
by serial command 3-15

Laser Scanning (enable/disable) 5-3

Light Source A-3

Longitudinal Redundancy Check
by menu selection 2-5, 2-9
by serial command 3-7

LRC. *See* Longitudinal Redundancy Check

M

Master Label
by operational command 5-5–5-6

Match Code
by menu selection 2-12, 2-19
by serial command 3-10

Match Code Master
by menu selection 2-20

Match Code Type
by menu selection 2-19

Match Counter Commands 5-4

Match Length
by menu selection 2-21

Match Start Position
by menu selection 2-21

Mechanical A-3

Menu Configuration Program 2-2
exiting 2-4
regaining access 3-4
resetting to default values 2-4
saving menu changes 2-4

Mismatch 5-5

TTL--Output #2 2-33
by menu selection 2-31
by serial command 3-15
Relay--Output #1 2-32

Mismatch Counter Commands 5-5

Mismatch or Noread
by menu selection 2-31
by serial command 3-15
Relay--Output #1 2-32
TTL--Output #2 2-33

Modulus 43 2-24

Motor Speed 1-16, 4-6

Mounting Holes
7100 1-18
7180 1-19

Multidrop
by menu selection 2-7
by serial command 3-5

Multidrop Address Characters A-24

Multidrop Communications A-21–A-23
multidrop addresses A-21
polling sequences A-22
select sequences A-23

N

Narrow Margins

by menu selection 2-23
by serial command 3-12

New Master Pin
by menu command 2-34
by menu selection 2-31, 2-34
by serial command 3-15

New Trigger
by menu selection 2-15
by serial command 3-9

Noise Interference A-9, A-15

Noread
by serial command 3-15
Relay--Output #1 2-32
TTL--Output #2 2-33

Noread (Relay Driver Option)
by menu selection 2-31

Noread Counter 5-4

Noread Message
by menu selection 2-12, 2-17
by serial command 3-10

Number of Labels
by menu selection 2-12, 2-18
by serial command 3-11

Number of Scans
7100 1-6
7180 1-7

O

Object Detector Orientation A-7–A-8

Operational Commands
code type 5-4
counter 5-4
program management 5-3
summary 5-2
test 5-5

Operational Tips 1-20

Operations
by menu selection 2-12–2-21
by serial command 3-9–3-11

Operations Status Request 3-11

Optical Characteristics A-4

Options (models) A-3

Output Polarity
by menu selection 2-31, 2-33
by serial command 3-16

Output Pulse Width
by menu selection 2-31, 2-33
by serial command 3-16

P

Parity
by menu selection 2-10

Parity (aux port)
by menu selection 2-11
by serial command 3-8

Partial Length
by menu selection 2-36

partial length
by serial command 3-16

Partial Output
by menu selection 2-36
by serial command 3-16

partial output status
by serial command 3-16

partial start position
by serial command 3-16

Picket Fence
orientation A-6

Picket Fence calculation
7100 1-6
7180 1-7

Point-to-Point
by menu selection 2-6
by serial command 3-5

Point-to-Point with RTS/CTS
by menu selection 2-6
by serial command 3-5

Point-to-Point with RTS/CTS & XON/XOFF
by menu selection 2-7
by serial command 3-5

Point-to-Point with XON/XOFF
by menu selection 2-6
by serial command 3-5

Poll Character A-24

Index

- Polling Mode D
 - by menu selection* 2-7
 - by serial command* 3-5
- Postamble
 - by menu selection* 2-9
 - by serial command* 3-7
- Power Connector 1-12, A-3
- Preamble
 - by menu selection* 2-8
 - by serial command* 3-7
- Protocol
 - by menu selection* 2-6
- Q**
- Quiet Zones 2-23
- R**
- Range 1-16
 - high density* 1-3
 - low density* 1-3
 - ultra high density* 1-3
- Raster
 - height* A-8
- Raster Arc 1-5
- Raster Height 1-5
- Raster On/Off
 - by menu selection* 2-37, 2-38
 - by serial command* 3-17
- Raster Setup
 - by menu selection* 2-37–2-38
 - by serial commands* 3-17
- Read Cycle
 - how to initiate or end* 2-13, 2-14
 - polarity* 2-16
 - triggered by object detector* A-7
 - triggered by serial trigger character* 2-16
- Read Rate Test
 - operational commands* 5-5
 - procedure* 1-15
 - troubleshooting* A-12
- Relay Driver
 - by menu selection* 2-31
- Relay Settings
 - by menu selection* 2-32
 - by serial command* 3-15
- Relay--Output #1
 - by menu selection* 2-32
- relay--output #1
 - by serial command* 3-15
- Request Master Label Information 5-6
- Response Timeout
 - by menu selection* 2-5, 2-9
 - by serial command* 3-7
- Reverse Video
 - by menu selection* 2-31, 2-34
 - by serial command* 3-16
- RS-232
 - definition* A-15
- RS-422
 - by menu selection* 2-11
 - definition* A-15
- RS-485
 - definition* A-15
 - See also Multidrop*
- S**
- Safety Labels ix
- Save Configuration 5-3
- Saving Configuration Changes. *See Configuration*
- Scan Rate 1-16, 4-6, 4-9, A-8
- Scan Width 1-4, 1-17
 - definition* A-8
- Scanner Setup
 - by serial command* 3-17
- Scanning Parameters A-3
- Scanning System 1-2
- Scans per Second 5-5
- Select Character A-24
- Separator Character
 - by menu selection* 2-22, 2-27
 - by serial command* 3-13
- Sequential (Matchcode)
 - by menu selection* 2-20

Sequential Matching
by menu selection 2-20

Serial Configuration Commands
concatenating 3-4
format 3-3
initializing changes 3-4
saving changes 3-4
summary 3-2

Serial Data
by menu selection 2-14
by serial command 3-9

Serial Data & Edge
by menu selection 2-14
by serial command 3-9

Serial Trigger Character
by menu selection 2-12, 2-16
by serial command 3-9

Shielding A-9

Small Bar 4-9

Software Part Number (display) 5-5

Software Reset > 5-3

Special Characters 2-4

Specifications A-2–A-4

Specular Reflection 1-14

Start & Stop Match
by menu selection 2-22, 2-25
by serial command 3-12

Start & Stop Output
by menu selection 2-25

Start Position (Partial Output)
by menu selection 2-36

Status Lights A-3

Stop Bits
by menu selection 2-10

Stop Bits (aux port)
by menu selection 2-11
by serial command 3-8

Store Next Label Scanned as Master Label 5-6

Supplementals
by menu selection 2-22, 2-27
by serial command 3-13

Sweeps per Second
by menu selection 2-37, 2-38
by serial command 3-17
formula 1-7

Symbology ID
by menu selection 2-23
by serial command 3-12

Symbology Identifier
by serial command 3-14

System Setup 1-2

T

Test and Autocalibrate 1-15

Timeout & New Trigger
by menu selection 2-15
by serial command 3-9

Timeout (end of read cycle option)
by menu selection 2-15
by serial command 3-9

Timeout in 10 ms incs
by menu selection 2-12, 2-16
by serial command 3-9

Top Offset in Degrees
by menu selection 2-37
by serial command 3-17

Tracking 1-17, 4-8

Transparent
by menu selection 2-5, 2-11
description A-16–A-17

Trigger Connector 1-11, A-3

Trigger Counter Commands 5-4

Trigger Filter Timing Value 3-11

Triggering Mode
by menu selection 2-13
by serial command 3-9

Troubleshooting A-11–A-13
operational tips 1-20

TTL--Output #2
by menu selection 2-33

TTL--output #2
by serial command 3-15

Index

U

UCC/EAN-128

by menu selection 2-22, 2-28

definition A-14

of code 128 (serial) 3-14

UPC/EAN

by serial command 3-13

definition A-14

EAN (menu) 2-22, 2-27

UPC (menu) 2-22, 2-27

User Defined

by menu selection 2-7

by serial command 3-5

User Defined Multidrop

by menu selection 2-8

by serial command 3-5

User Outputs

by menu selection 2-31–2-36

by serial command 3-15–3-17

User Outputs Status Request 3-17

W

Warning and Caution Summary viii

Warranty Statement ii

When to Output

by menu selection 2-12, 2-17

by serial command 3-10

Wild Card (Matchcode)

by menu selection 2-20

Wild Card Character (Match Code) 2-21