

EZ Match - CONFIGURATION

MICROSCAN.



USB (5V)

This is the basic setup for a single USB EZ Match Imager. The EZ Match is connected directly to a host computer.

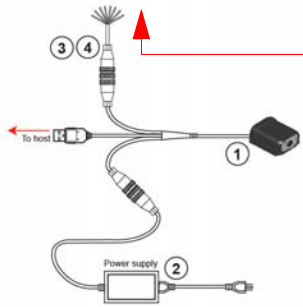

To 5V trigger or stripped cable (eight flying leads).
 Default
 Output 1
 Output 2
 Output 3
 Trigger
 +5VDC
 Ground
 New Master

System Matrix

Product	Part Number	Description
(1) EZ Match	FIS-0004-100XG	1-Megapixel B&W or 3-Megapixel Color option available
(2) Power Supply	97-000002-02	90-264 VAC, +5VDC
(3) Object Detector (optional)	99-000019-01	Photo Sensor, Visible, NPN, Light On
(4) Breakout Cable	61-000151-01	Cable, USB, Breakout, Flying Leads, 3 ft.

Stand-Alone (10-28V)

This is the basic 10-28-volt setup for a single EZ Match Imager.

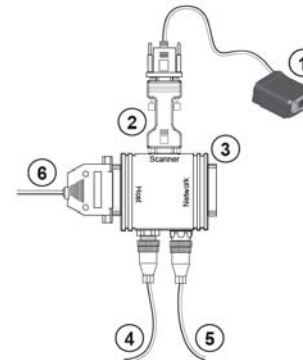

System Matrix

Product	Part Number	Description
(1) EZ Match	FIS-0004-100XG	1-Megapixel B&W or 3-Megapixel Color option available
(2) IC-332	FIS-0001-0035G	Voltage converter (to 10-28V)
(3) IB-131	99-000018-01	Interface Box
(4) Power Supply	97-100004-15	90-264 VAC, 24VDC, USA/Euro plug
(5) Object Detector	99-000017-01	Photo Sensor, Visible, NPN, Dark On
(6) Communication Cable	61-300026-03	25-pin plug to 9-pin socket

Daisy Chain (10-28V)

A primary imager is linked directly to the host. Secondary imagers are linked in tandem. Data is sent from each secondary imager to the primary imager, and from the primary imager to the host.

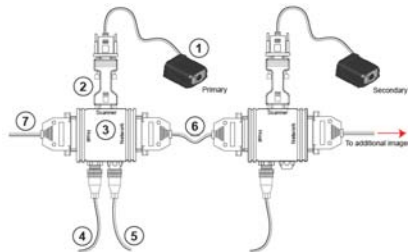

System Matrix

Product	Part Number	Description
(1) EZ Match	FIS-0004-100XG	1-Megapixel B&W or 3-Megapixel Color option available
(2) IC-332	FIS-0001-0035G	Voltage converter (to 10-28V)
(3) IB-131	99-000018-01	Interface Box
(4) Power Supply	97-100004-15	90-264 VAC, 24VDC, USA/Euro plug
(5) Object Detector	99-000017-01	Photo Sensor, Visible, NPN, Dark On
(6) Daisy Chain Cable	61-100029-03	IB-131 to IB-131, 1 ft.
(7) Communication Cable	61-300026-03	25-pin plug to 9-pin socket

Stand-Alone with MS-Connect 210 (10-28V)

This is the basic setup for a single EZ Match Imager and an MS-Connect 210 Connectivity Box.

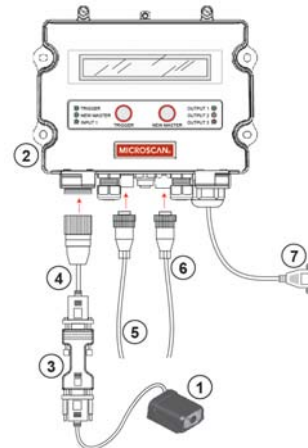

System Matrix

Product	Part Number	Description
(1) EZ Match	FIS-0004-100XG	1-Megapixel B&W or 3-Megapixel Color option available
(2) MS-Connect 210	FIS-0210-000XG	Connectivity Box
(3) IC-332	FIS-0001-0035G	Voltage converter (to 10-28V)
(4) Reader Cable	61-000127-01	EZ Match to MS-Connect 210 cable, 6 ft.
(5) Power Supply	97-100004-15	90-264 VAC, 24VDC, USA/Euro plug
(6) Object Detector	99-000017-02	Photo Sensor, Visible, NPN, Light On
(7) Host Cable	61-000105-01	MS-Connect 210 to host, user-stripped to 9-pin (included)