



METROLOGIC INSTRUMENTS, INC.

MS1690 Focus™

Area Imaging Bar Code Scanner
Installation and User's Guide



Copyright

© 2005 by Metrologic Instruments, Inc. All rights reserved. No part of this work may be reproduced, transmitted, or stored in any form or by any means without prior written consent, except by reviewer, who may quote brief passages in a review, or provided for in the Copyright Act of 1976.

Products and brand names mentioned in this document are trademarks of their respective companies.

TABLE OF CONTENTS

Introduction	1
Scanner and Accessories	2
Scanner Components	4
The PowerLink Cable	5
Labels	6
Maintenance	6
Installing the Scanner to the Host System	
RS232 MS1690-14	7
Keyboard Wedge MS1690-47	8
Stand Alone Keyboard MS1690-47	9
IBM MS1690-11	10
Full Speed USB MS1690-40 (Integrated)	11
Low Speed USB MS1690-38 (Integrated)	11
Stand Kits	
Stand Components, MLPN 46-00147	12
Hard Mounting the Stand	13
Assembling the Stand	14
Scanner Operation	
Two Default Modes of Operation	15
Audible Indicators	16
Visual Indicators	17
Failure Modes	18
Depth of Field by Minimum Bar Code Element Width	19
IR Activation Range	20
Troubleshooting Guide	21
Design Specifications	25
Applications and Protocols	27
Default Settings – Communication Parameters	28
Configuration Modes	32
Upgrading the Flash ROM Firmware	33

TABLE OF CONTENTS

Scanner and Cable Terminations	
Scanner Pinout Connections	34
Cable Connector Configurations	36
Limited Warranty	38
Product Safety	
Notices	39
Cautions	40
Patents	41
Index	42
Contact Information and Office Locations.....	45

INTRODUCTION

The MS1690 Focus is a high performance hand-held area imaging bar code scanner that utilizes high-resolution CMOS imaging sensors for superior image quality. Focus utilized Omniplanar, Inc.'s Swiftdecoder™ software, for reliable decoding of both 1D and 2D bar code symbologies. Sharp images can be captured and transmitted in a variety of outputs including: .jpg, .bmp, and .tiff.

Omnidirectional scanning capabilities and an extended depth of field width provides aggressive scanning of all standard 1D, RSS, PDF417, microPDF, Composite, Matrix and Postal Codes symbology types. Firmware updates are easily loaded via Flash ROM.

Focus provides an extended depth of field width and a built in object detection sensor (IR) that instantly turns on the scanner when an object is presented within the scanner's field of view. Automatic in-stand detection switches the scanner to a "presentation" mode for convenient in-stand scanning. Focus incorporates Metrologic's patented CodeGate® technology for accurate menu style scanning and on command data transmission.

Focus™	Interface
MS1690 – 11	IBM 468X/469X, RS232-TXD, RXD, RTS, CTS
MS1690 – 14	RS232 (TX, RX, RTS, CTS, DTR)
MS1690 – 38	Low Speed USB
MS1690 – 40	Full Speed USB
MS1690 – 47	Keyboard Wedge, Stand-Alone Keyboard and RS232 Transmit/Receive

INTRODUCTION

Scanner and Accessories

BASIC KIT	
Part #	Description
MS1690	Focus Area Imaging Bar Code Scanner
00-02544	MetroSelect® Single-Line Configuration Guide*
00-02065	Supplemental Configuration Guide*
00-02098	MS1690 Focus Area Imaging Bar Code Scanner Installation and User's Guide*

* Available on the Metrologic website - www.metrologic.com

OPTIONAL ACCESSORIES	
Part #	Description
AC to DC Power Transformer - Regulated 5.2VDC @ 650 mA output.	
45-45593	120V United States
45-45591	220V-240V Continental European
45-45592	220V-240V United Kingdom
46-46803	220V-240V Australia
46-46983	220V-240V China
53-53000-3	RS232 PowerLink Cable with Built in Power Jack 2.7 m (9 ft.) coiled cord, long strain relief, black
53-53002-3	Keyboard Wedge PowerLink Cable with Adapter Cable 2.7 m (9 ft.) coiled cord, long strain relief, black
53-53020-3	Stand Alone Keyboard PowerLink Cable 2.7 m (9 ft.) coiled cord, long strain relief, black

Other items may be ordered for the specific protocol being used. To order additional items, contact the dealer, distributor or call Metrologic's Customer Service Department at 1-800-ID-METRO or 1-800-436-3876.

Scanner and Accessories

OPTIONAL ACCESSORIES	
Part #	Description
53-53213x-N-3	USB Power/Communication Cable, 2.7 m (9 ft.) coiled cord, long strain relief, black
53-53214x-N-3	USB Power/Communication Cable, 4.5 m (15 ft.) coiled cord, long strain relief, black  This cable is for use with full speed USB (-40) interface only.
53-53235x-N-3	Low Speed USB Non-Locking Communication Cable 2.7 m (9 ft.) coiled cord, long strain relief, black
MVC-2MPC-IB9	Metrologic Voltage Converter (MVC) Cable* ±12VDC to +5.2VDC
<i>* Contact a Metrologic customer service representative for additional information on the MVC cable series and the host connections available.</i>	
00-02001	MS1690 Focus Stand (46-00147) Installation Guide
46-00147	Modular Presentation Stand

Other items may be ordered for the specific protocol being used. To order additional items, contact the dealer, distributor or call Metrologic's Customer Service Department at 1-800-ID-METRO or 1-800-436-3876.

Scanner Components

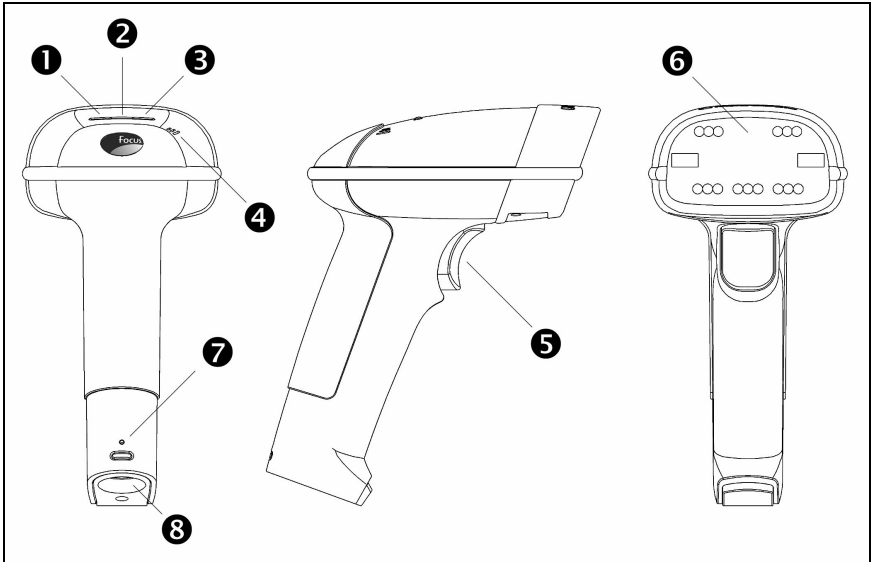

Figure 1. Scanner Components

Item Description		
1	Yellow LED	See <i>Visual Indicators</i> (on page 17)
2	White LED	See <i>Visual Indicators</i> (on page 17)
3	Blue LED	See <i>Visual Indicators</i> (on page 17)
4	Speaker	See <i>Audible Indicators</i> (on page 16)
5	Trigger	
6	Red Window	LED Aperture
7	Cable Release	See <i>The PowerLink Cable</i> (on page 5)
8	Cable Connection	10-pin RJ45, Female Socket, See <i>Scanner Pinout Connections</i> (on page 34)

THE POWERLINK CABLE

CONNECTING



Important: If the PowerLink cable is not fully 'latched' the unit can power intermittently.

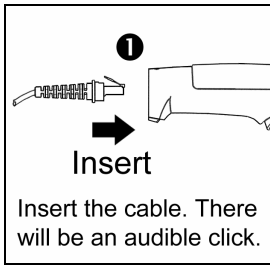

Figure 2.

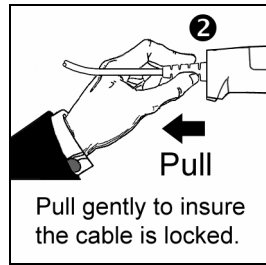

Figure 3.

DISCONNECTING

Before removing the cable from the scanner, Metrologic recommends that the power on the host system is off and the power supply has been disconnected from the PowerLink cable.

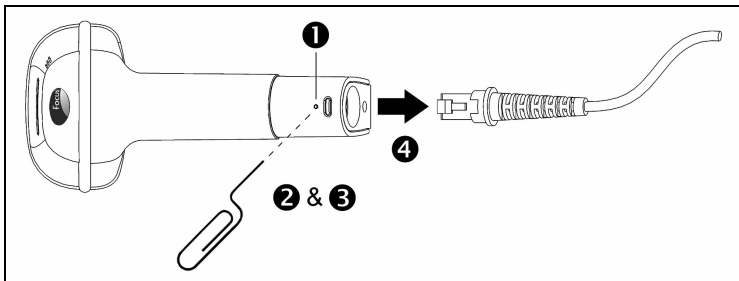

Figure 4. Releasing the PowerLink Cable

1. Locate the small 'pin-hole' on the handle of the unit near the cable.
2. Bend an ordinary paperclip into the shape shown above.
3. Insert the paperclip (or other small metallic pin) into the small 'pin-hole'.
4. You will here a faint 'click'. Pull gently on the strain-relief of the PowerLink cable to remove the cable from the unit.

INTRODUCTION

Labels

Each scanner has a label located on the underside of the head. This label provides the unit's model number, date of manufacture, serial number, CE and caution information. The following figure gives an example of the label and its location.

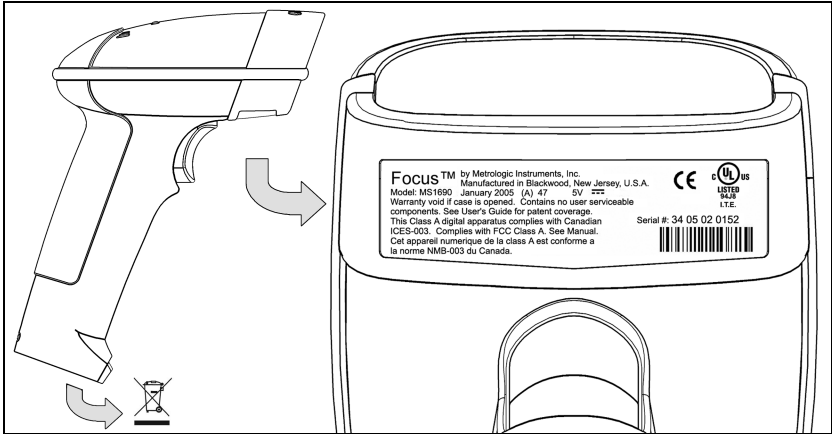

Figure 5. Label Samples and Location

Maintenance

Smudges and dirt can interfere with the proper scanning of a bar code. Therefore, the output window will need occasional cleaning.

1. Spray glass cleaner onto lint free, non-abrasive cleaning cloth.
2. Gently wipe the scanner window.

INSTALLING THE SCANNER TO THE HOST SYSTEM

RS232 MS1690-14

1. Turn off the host device.
2. Plug the male 10-pin RJ45 end of the PowerLink cable into the 10-pin socket on the Focus. You will hear a 'click' when the connection is made.
3. Connect the 9-pin D-type connector of the communication cable to the proper COM port of the host device.
4. Plug the power supply into the power jack on the PowerLink cable.



Check the AC input requirements of the power supply to make sure the voltage matches the AC outlet. The outlet must be located near the equipment and be easily accessible.

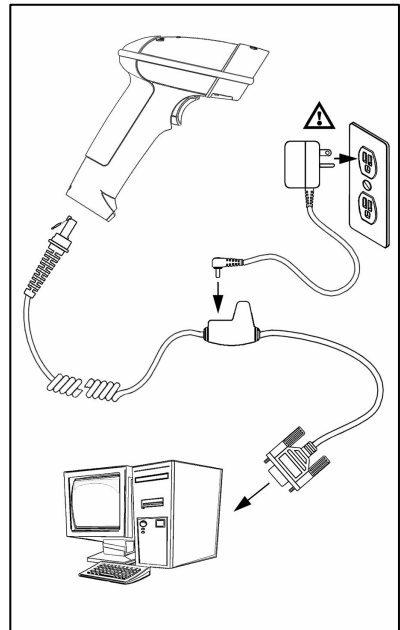

Figure 6.

5. Connect AC power to the transformer.
6. Focus will start to initialize. All LEDs (yellow, white, and blue) will light for approximately 2 seconds then start to alternately flash. When the scanner has finished initializing the LEDs will stop flashing and the unit will beep 3 times indicating that the scanner is ready for use.
7. Turn on the host device.



Plugging the scanner into a port on the host system does not guarantee that scanned information will be communicated properly to the host system. The scanner is shipped from the factory configured with default settings. Please refer to the MetroSelect Single-Line Configuration Guide (MLPN 00-02544) or MetroSet2's help files for instructions on changing the scanner's configuration. In addition, please check that the scanner and host system are using the same communication protocol.

Caution:

To maintain compliance with applicable standards, all circuits connected to the scanner must meet the requirements for SELV (Safety Extra Low Voltage) according to EN/IEC 60950.



To maintain compliance with standard CSA-C22.2 No. 60950-00/UL 60950 and norm EN/IEC 60950, the power source should meet applicable performance requirements for a limited power source.

INSTALLING THE SCANNER TO THE HOST SYSTEM

Keyboard Wedge MS1690-47

1. Turn off the host device.
2. Plug the 10-pin RJ45 male end of the PowerLink cable into 10-pin socket on the Focus. You will hear a 'click' when the connection is made.
3. Disconnect the keyboard from the host device.
4. Connect the "Y" ends of the communication cable to the keyboard and keyboard port on the host device. If necessary use the male/female adapter cable supplied with the scanner for proper connections.
5. Plug the external power supply (*required*) into the power jack on the PowerLink cable.



Check the AC input requirements of the power supply to make sure the voltage matches the AC outlet. The outlet must be located near the equipment and be easily accessible.

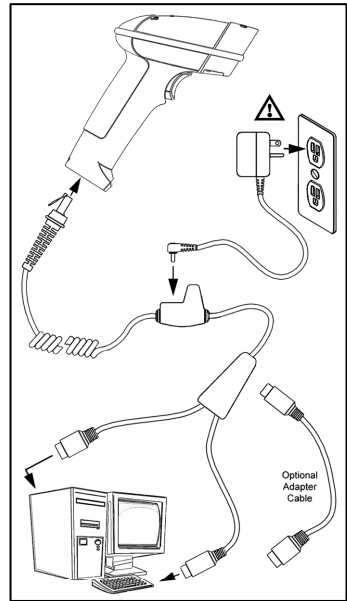

Figure 7.

6. Connect AC power to the transformer.
7. Focus will start to initialize. All LEDs (yellow, white, and blue) will light for approximately 2 seconds then start to alternately flash. When the scanner has finished initializing the LEDs will stop flashing and the unit will beep 3 times indicating that the scanner is ready for use.
8. Turn on the host device.



Plugging the scanner into a port on the host system does not guarantee that scanned information will be communicated properly to the host system. The scanner is shipped from the factory configured with default settings. Please refer to the MetroSelect Single-Line Configuration Guide (MLPN 00-02544) or MetroSet2's help files for instructions on changing the scanner's configuration. In addition, please check that the scanner and host system are using the same communication protocol.



Caution:

To maintain compliance with applicable standards, all circuits connected to the scanner must meet the requirements for SELV (Safety Extra Low Voltage) according to EN/IEC 60950.

To maintain compliance with standard CSA-C22.2 No. 60950-00/UL 60950 and norm EN/IEC 60950, the power source should meet applicable performance requirements for a limited power source.

INSTALLING THE SCANNER TO THE HOST SYSTEM

Stand Alone Keyboard MS1690-47

1. Turn off the host device.
2. Plug the male 10-pin RJ45 end of the PowerLink cable into the 10-pin socket on the Focus. You will hear a 'click' when the connection is made.
3. Plug the other end of the communication cable into the host's keyboard port.
4. Plug the external power supply into the power jack on the PowerLink cable.



Check the AC input requirements of the power supply to make sure the voltage matches the AC outlet. The outlet must be located near the equipment and be easily accessible.

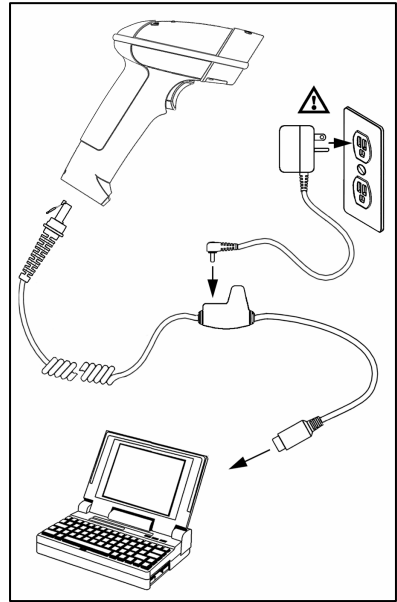

Figure 8.

5. Connect AC power to the transformer.
6. Focus will start to initialize. All LEDs (yellow, white, and blue) will light for approximately 2 seconds then start to alternately flash. When the scanner has finished initializing the LEDs will stop flashing and the unit will beep 3 times indicating that the scanner is ready for use.
7. Turn on the host device.



Plugging the scanner into a port on the host device does not guarantee that scanned information will be communicated properly to the host device. The scanner is shipped from the factory configured with default settings. Please refer to the MetroSelect Single-Line Configuration Guide (MLPN 00-02544) or MetroSet2's help files for instructions on changing the scanner's configuration. In addition, please check that the scanner and host system are using the same communication protocol.



Caution:

To maintain compliance with applicable standards, all circuits connected to the scanner must meet the requirements for SELV (Safety Extra Low Voltage) according to EN/IEC 60950.

To maintain compliance with standard CSA-C22.2 No. 60950-00/UL 60950 and norm EN/IEC 60950, the power source should meet applicable performance requirements for a limited power source.

INSTALLING THE SCANNER TO THE HOST SYSTEM

IBM MS1690-11

1. Turn off the host device.
2. Plug the male 10-pin RJ45 end of the MVC cable into the 10-pin socket on the Focus. You will hear a 'click' when the connection is made.
3. Connect the other end of the MVC cable to the host device.
4. Turn on the host device.
5. Focus will start to initialize. All LEDs (yellow, white, and blue) will light for approximately 2 seconds then start to alternately flash. When the scanner has finished initializing the LEDs will stop flashing and the unit will beep 3 times indicating that the scanner is ready for use.

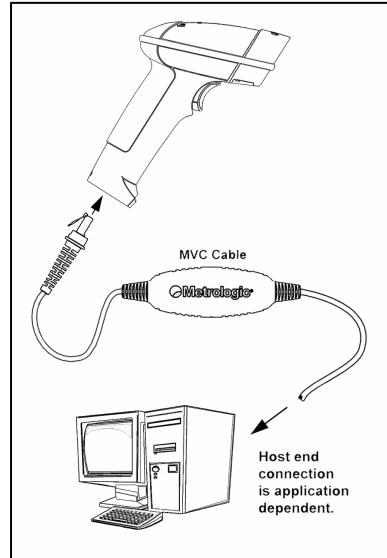

Figure 9.



Plugging the scanner into a port on the host system does not guarantee that scanned information will be communicated properly to the host system. The scanner is shipped from the factory configured with default settings. Please refer to the MetroSelect Single-Line Configuration Guide (MLPN 00-02544) or MetroSet2's help files for instructions on changing the scanner's configuration. In addition, please check that the scanner and host system are using the same communication protocol.



Caution:

To maintain compliance with applicable standards, all circuits connected to the scanner must meet the requirements for SELV (Safety Extra Low Voltage) according to EN/IEC 60950.

To maintain compliance with standard CSA-C22.2 No. 60950-00/UL 60950 and norm EN/IEC 60950, the power source should meet applicable performance requirements for a limited power source.

INSTALLING THE SCANNER TO THE HOST SYSTEM

Integrated USB:

Full Speed MS1690-40

Low Speed MS1690-38

1. Turn off the host device.
2. Plug the male 10-pin RJ45 end of the USB cable into the 10-pin socket on the Focus. You will hear a 'click' when the connection is made.
3. Plug the USB type A end of the USB cable into the host's USB port.
4. Turn on the host device.
5. Focus will start to initialize. All LEDs (yellow, white, and blue) will light for approximately 2 seconds then start to alternately flash. When the scanner has finished initializing the LEDs will stop flashing and the unit will beep 3 times indicating that the scanner is ready for use.

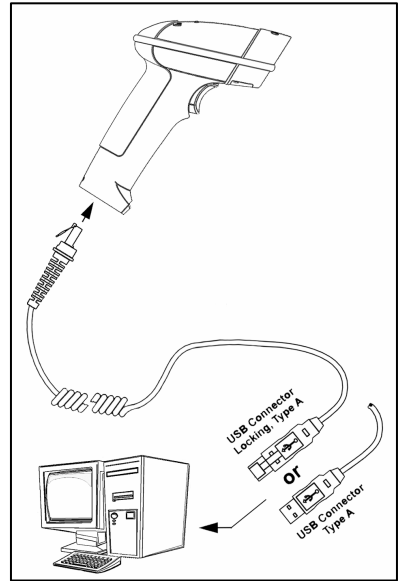

Figure 10.



As a default, the MS1690-38 leaves the factory with USB Keyboard Emulation Mode enabled.

For information on configuring the MS1690-38 for USB Serial Emulation Mode, please refer to the USB section of the MetroSelect Single-Line Configuration Guide (MLPN 00-02544).



Plugging the scanner into a port on the host device does not guarantee that scanned information will be communicated properly to the host device. The scanner is shipped from the factory configured with default settings. Please refer to the MetroSelect Single-Line Configuration Guide (MLPN 00-02544) or MetroSet2's help files for instructions on changing the scanner's configuration. In addition, please check that the scanner and host system are using the same communication protocol.

Caution:



To maintain compliance with applicable standards, all circuits connected to the scanner must meet the requirements for SELV (Safety Extra Low Voltage) according to EN/IEC 60950.

To maintain compliance with standard CSA-C22.2 No. 60950-00/UL 60950 and norm EN/IEC 60950, the power source should meet applicable performance requirements for a limited power source.

STAND KITS

STAND COMPONENTS, MLPN 46-00147

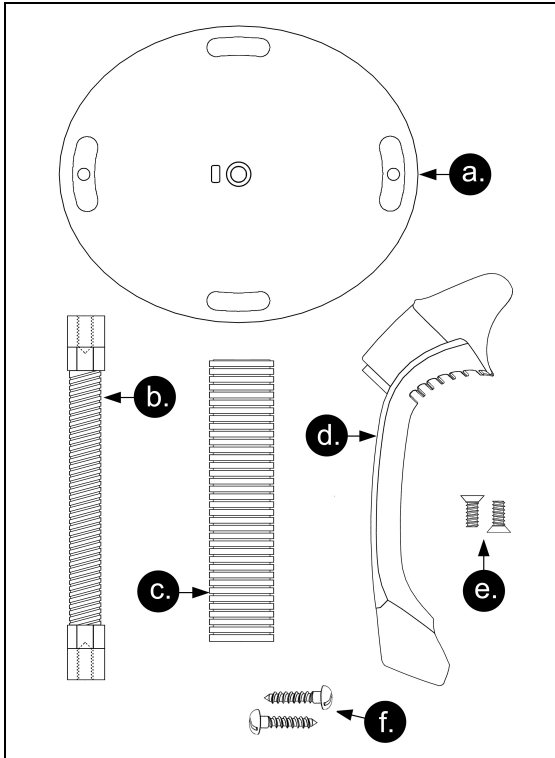

Figure 11. Stand Components

Item	Description	Qty.
a.	Stand Base	Qty. 1
b.	Flexible Shaft	Qty. 1
c.	Flexible Shaft Cover	Qty. 1
d.	Scanner Cradle	Qty. 1
e.	1/4" – 20 x 3/8" Flat Head Phillips, 82° Undercut	Qty. 2
f.	#8 Round Head Wood Screw	Qty. 2

HARD MOUNTING THE STAND (OPTIONAL)

Metrologic provides two #8 wood screws for securing the stand base to the counter top. The following figure provides the pilot hole dimensions for securing the stand base.

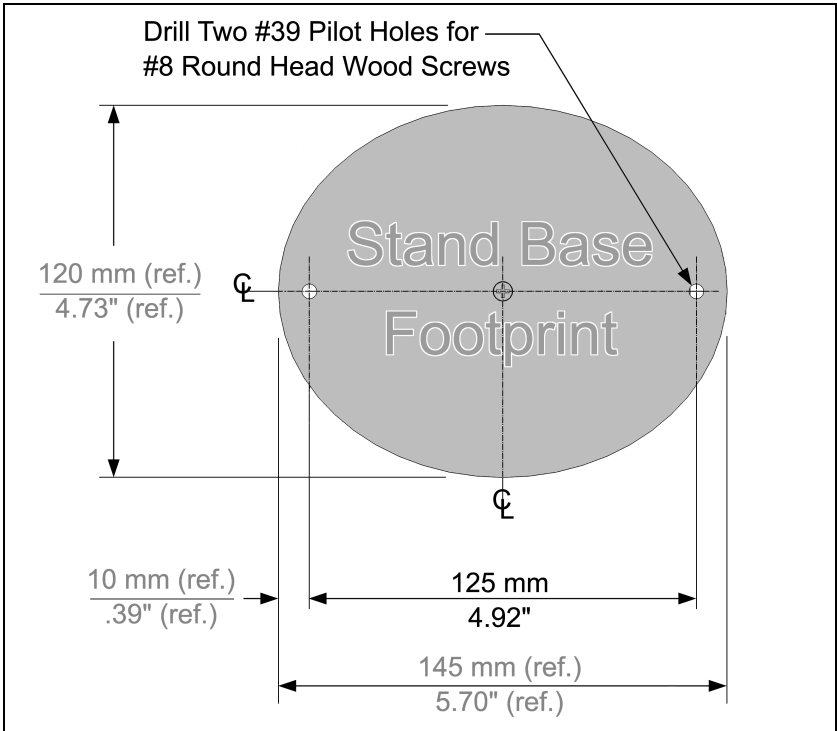

Figure 12. Stand Base Hole Pattern (Not to Scale)

ASSEMBLING THE STAND

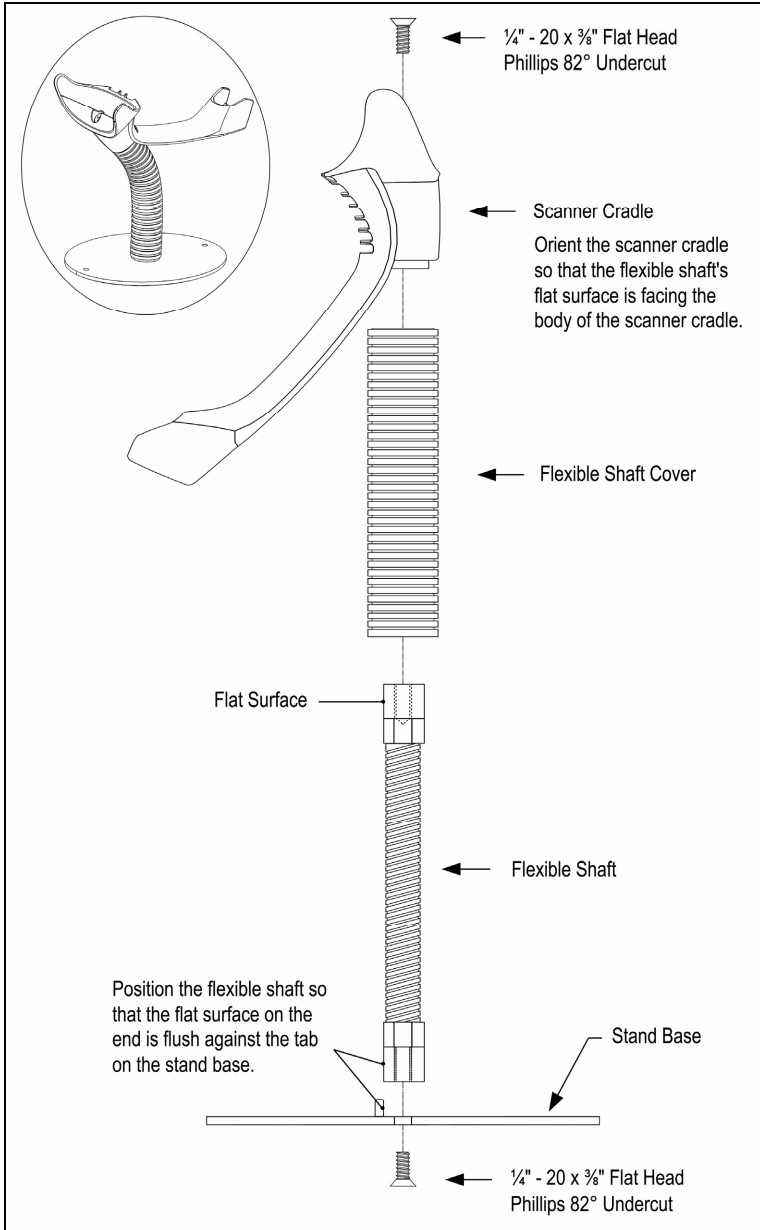



Figure 13. Assembling the Stand

SCANNER OPERATION

TWO DEFAULT MODES OF OPERATION*

CodeGate, Out of Stand

1. The IR detects an object in the IR activation range and automatically turns on linear illumination.
2. Aim the scanner's line of light over the bar code.
3. Pull the trigger to initiate scanning. The scanner's light output will start to flash as it attempts to scan the bar code.

 If the trigger is released the scanner will stop trying to scan.

4. When scanner successfully reads the bar code it will beep once, the white LED will flash and the decoded data will be transmitted to the host.

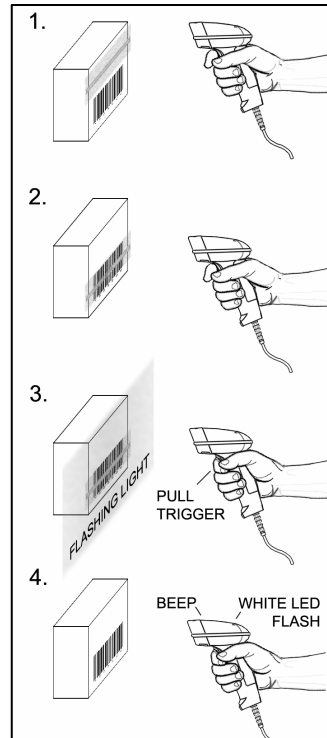

Figure 14. CodeGate, Out-of-Stand

Presentation, In-Stand

1. The IR detects an object in the IR activation range and the scanner's light output automatically starts to flash as it attempts to scan the bar code.
2. The scanner continuously attempts to scan the bar code until either it succeeds or the bar code is removed from the scanner's field of view.
3. When scanner successfully reads the bar code it will beep once, the white LED will flash and the decoded data will be transmitted to the host.

* For additional configurable modes of operation, please refer to the MS1690 Focus Supplemental Configuration Guide (MLPN 00-02065).

Audible Indicators

When the Focus is in operation, it provides audible feedback. These sounds indicate the status of the scanner. Eight settings are available for the tone of the beep (normal, 6 alternate tones and no tone). To change the tone, refer to the MetroSelect Single-Line Configuration Guide, MLPN 00-02544 or MetroSet2's help files.

One Beep

When the scanner *successfully* reads a bar code it will beep once and the white LED will turn on indicating data is being transmitted.

If the scanner does not beep once and the white light does not turn on, then the bar code has *not* been successfully read.

Short Razzberry Tone

This tone is a failure indicator (see Failure Modes on page 18).

Long Razzberry Tone

This tone is a failure indicator (see Failure Modes on page 18).

Three Beeps - At Power Up

When Focus first receives power it will start an initialization sequence. All LEDs (yellow, white, and blue) will light for approximately 2 seconds then start to alternately flash. When the scanner has finished initializing the LEDs will stop flashing and the unit will beep 3 times indicating that the scanner is ready for use.

Three Beeps - Configuration Mode

When entering configuration mode, the white LED will flash while the scanner simultaneously beeps three times. The white and blue LEDs will continue to flash while in this mode. Upon exiting configuration mode, the scanner will beep three times, and the LEDs will stop flashing.

When configured, 3 beeps can also indicate a communications timeout during normal scanning mode.

When using single-code-configuring, the scanner will beep three times: a normal tone followed by a short pause, a high tone and then a low tone. This indicates that the single configuration bar code has successfully configured the scanner.

Visual Indicators

The MS1690 has three LED indicators (yellow, white and blue) located on the top of the scanner. When the scanner is on, the flashing or stationary activity of the LEDs indicates the status of the current scan and the scanner.

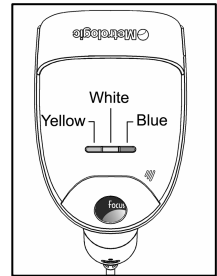

Figure 15.

No LEDs are Illuminated

The LEDs will not be illuminated if the scanner is not receiving power from the host or transformer.

The scanner is in stand-by mode. Present a bar code to the scanner and the blue LED will turn on when the IR detects the object.

Steady Yellow

The yellow LED is illuminated when the scanner is in the stand.

Steady Blue

The blue LED is illuminated when the scanner is active and linear illumination is on or when the scanner is attempting to decode a barcode.

Steady Blue and Single White Flash

When the scanner successfully reads a bar code it will beep once and the white LED will turn on indicating data is being transmitted.

If the scanner does not beep once and the white light does not turn on, then the bar code has not been successfully read.

Steady White

When the scanner successfully reads a bar code it will beep once and the white LED will turn on indicating data is being transmitted.



After a successful scan, the scanner transmits the data to the host device. Some communication modes require that the host inform the scanner when data is ready to be received. If the host is not ready to accept the information, the scanner's white LED will remain on until the data can be transmitted.

Alternating Flashing of Blue and White

This indicates the scanner is in configuration mode. A short razzberry tone indicates that an invalid bar code has been scanned while in this mode.

Flashing Blue

The blue LED will flash if the trigger is pressed while the scanner is in the in-stand presentation mode. The blue LED will stop flashing after a brief period of time.

Failure Modes

Long Razzberry Tone – During Power Up

Failed to initialize or configure the scanner. If the scanner does not respond after reprogramming, return the scanner for repair.

Short Razzberry Tone – During Scanning

An Invalid bar code has been scanned when in configuration mode or the trigger has been pulled too fast.

Depth of Field by Minimum Bar Code Element Width

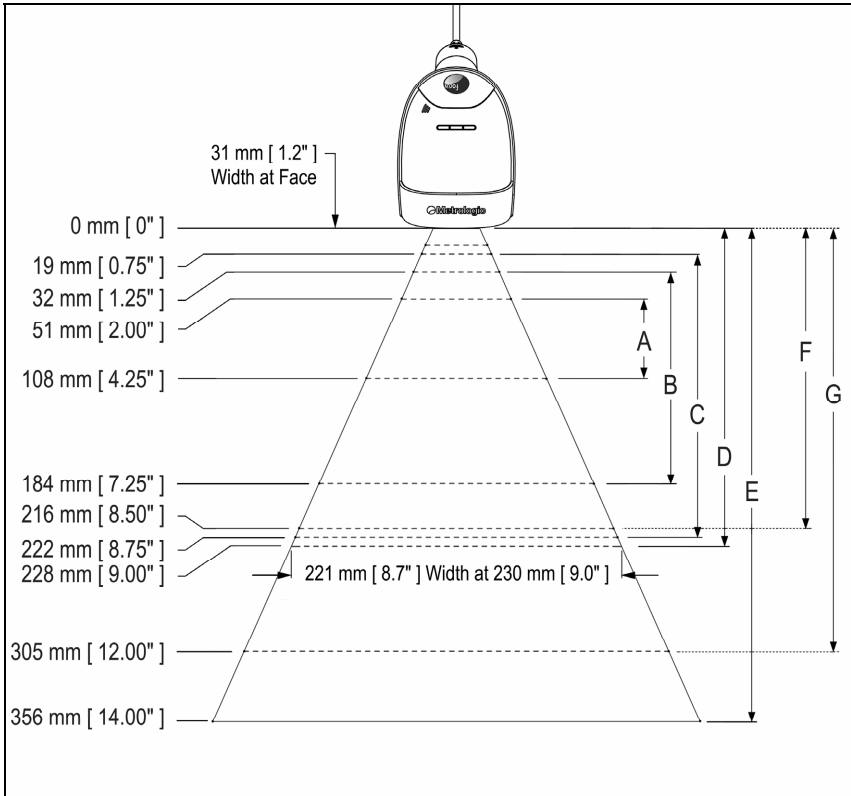

Figure 16. Depth of Field by Minimum Bar Code Element Width

MINIMUM BAR CODE ELEMENT WIDTH							
1D						PDF	
	A	B	C	D	E	F	G
mm	.132	.19	.254	.33	.533	.254	.381
mils	5.2	7.5	10.4	13	21	10	15.9

Specifications are subject to change without notice.

IR Activation Range

The MS1690 has a built in object detection sensor that instantly turns on the scanner when an object is presented within the scanner's IR activation Area.

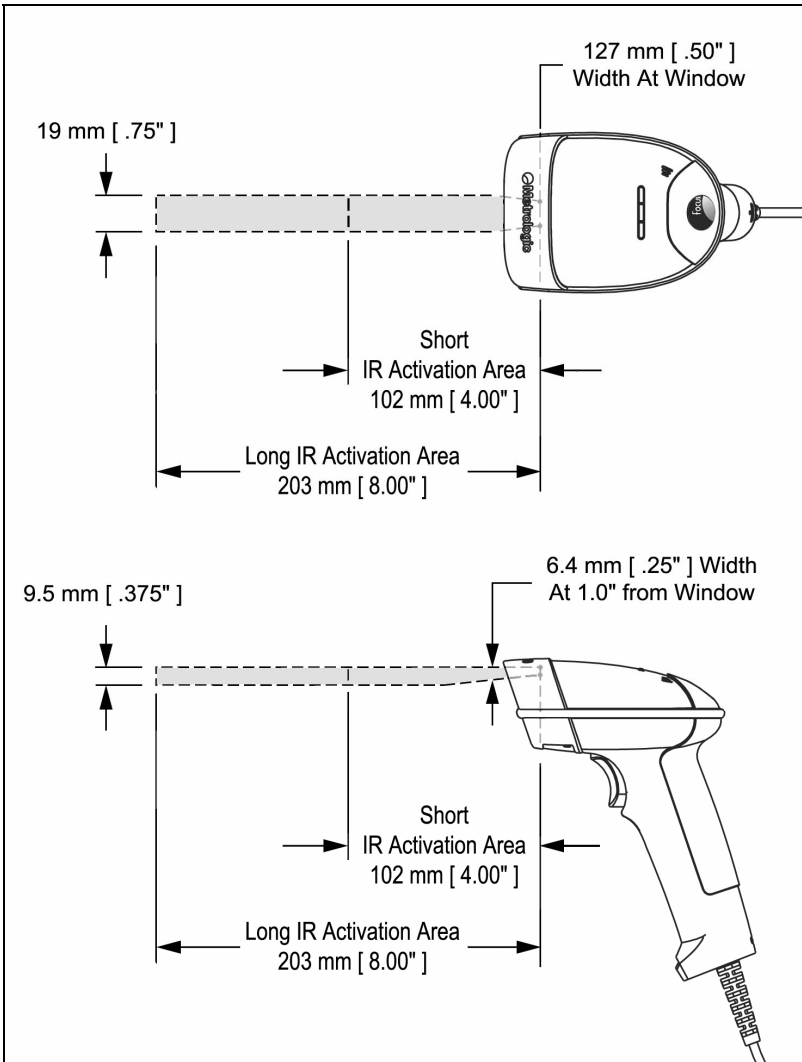

Figure 17. IR Activation Area

Specifications are subject to change without notice.

TROUBLESHOOTING GUIDE

The following guide is for reference purposes only. Contact a Metrologic representative at 1-800-ID-Metro or 1-800-436-3876 to preserve the limited warranty terms.

All Interfaces

MS1690 Series Troubleshooting Guide		
Symptoms	Possible Causes	Solution
No LEDs, beep or illumination	No power is being supplied to the scanner.	Check transformer, outlet and power strip. Make sure the cable is plugged into the scanner.
	No power is being supplied to the scanner from the host.	Some host systems cannot supply enough current to power Focus. A power supply may be required.
Long Razz tone on power up	The wrong communication cable has been used.	Check that the communication cable matches the unit type and scanner configuration.
	There has been a scanner configuration failure.	Contact a Metrologic service representative, if the unit will not hold the saved configuration.
	There has been a RAM or ROM failure.	Contact a Metrologic service representative, if the unit will not function.
Long Razz tone when exiting configuration mode	There was a failure to save the new configuration.	Re-try to configure the scanner. Contact a Metrologic Service Representative if the unit will not hold the saved configuration.
Long Razz tone	There is a scanning mechanism failure.	Contact a Metrologic service representative.
Short Razz tone in configuration mode	An invalid bar code has been scanned.	Scan a valid bar code or quit configuration mode.

TROUBLESHOOTING GUIDE

Symptoms	Possible Causes	Solution
The unit powers up, but does not beep when bar code is scanned.	The beeper is disabled and no tone is selected.	Enable the beeper and select a tone.
The unit powers up, but does not scan and/or beep.	The bar code symbology trying to be scanned is not enabled.	UPC/EAN, Code 39, interleaved 2 of 5, Code 93, Code 128, Codabar and PDF are enabled by default. Verify that the type of bar code being read has been selected.
The unit powers up, but does not scan and/or beep.	The scanner is trying to scan a barcode that does not match the configured criteria.	Verify that the bar code being scanned falls into the configured criteria (i.e. character length lock or minimum bar code length settings).
The unit scans a bar code, but locks up after the first scan and the white LED stays on.	The scanner is configured to support some form of host handshaking but is not receiving the signal.	If the scanner is setup to support ACK/NAK, RTS/CTS, or XON/XOFF, verify that the host cable and host are supporting the handshaking properly.
The unit scans, but the data transmitted to the host is incorrect.	The scanner's data format does not match the host system requirements.	Verify that the scanner's data format matches that required by the host. Make sure that the scanner is connected to the proper host port.

TROUBLESHOOTING GUIDE

Symptoms	Possible Causes	Solution
The unit beeps at some bar codes and NOT for others of the same bar code symbology.	The print quality of the bar code is suspect.	Check print mode. The type of printer could be the problem. Change print settings (i.e. change to econo mode or high speed).
	The aspect ratio of the bar code is out of tolerance.	Check print mode. The type of printer could be the problem. Change print settings (i.e. change to econo mode or high speed).
	The bar code may have been printed incorrectly.	Check if it is a check digit/character/or border problem.
	The scanner is not configured correctly for this type of bar code.	Check if check digits are set properly.
	The minimum symbol length setting does not work with the bar code.	Check if the correct minimum symbol length is set.
The unit scans the bar code but there is no data.	The configuration is not set correctly.	Make sure the scanner is configured for the appropriate mode.
The unit scans but the data is not correct.	The configuration is not set correctly.	Make sure that the proper PC type AT, or PS2 is selected. Verify correct country code and data formatting are selected. Adjust inter-character delay symptom.
	The scanner and host may not be configured for the same interface parameters.	Check that the scanner and the host are configured for the same interface parameters.

TROUBLESHOOTING GUIDE

Symptoms	Possible Causes	Solution
The unit is transmitting each character twice.	The configuration is not set correctly.	Increase interscan code delay setting. Adjust whether the F0 break is transmitted. It may be necessary to try this in both settings.
Alpha characters show as lower case.	The computer is in Caps Lock mode.	Enable Caps Lock detect setting of the scanner to detect if the PC is operating in Caps Lock.
Everything works except for a couple of characters.	These characters may not be supported by that country's key look up table.	Try operating the scanner in Alt mode.
The unit powers up OK and scans OK but does not communicate properly with the host.	The com port at the host is not working or not configured properly.	Check to make sure that the baud rate and parity of the scanner and the communication port match and the program is looking for "RS232" data.
	The cable is not connected to the correct com port.	Check to make sure that the cable is connected to the correct com port.
Characters are being dropped.	Inter-character delay needs to be added to the transmitted output.	Add some inter-character delay to the transmitted output by using the Configuration Guides (MLPN 00-02544 and 00-02065).

DESIGN SPECIFICATIONS

MS1690 DESIGN SPECIFICATIONS		
OPERATIONAL		
Light Source:	LED 645 nm	
Pulse Duration:	1 ms to 8 ms	
Maximum Output of an Osram LED:	Maximum 85 mA emits 3,120 mlm	
Depth of Scan Field:	0 mm – 230 mm (0" – 9") for 0.330 mm (13 mil) Bar Code at Default Setting	
Field of View:	49 mm W x 19 mm H (1.9" W x 0.8" H) at 20 mm (0.8") 264 mm x 106 mm (10.4" W x 4.2" H) at 280 mm (11.0")	
Minimum Bar Width:	0.127 mm (5.0 mil)	
Infrared Activation:	Long Range: 0 mm – 203 mm (0" – 8") from Window Short Range: 0 mm – 101 mm (0" – 4") from Window	
Decode Capability:	Autodiscriminates All Standard 1-D, RSS, PDF417, microPDF, MaxiCode, Data Matrix, QR Code, UCC, EAN Composites, Postals, Aztec <i>(Image Transfer)</i> – BMP, TIFF, or JPEG output	
System Interfaces:	PC Keyboard Wedge, RS232, IBM 468X/469X, Stand Alone Keyboard, USB (Low Speed and Full Speed)	
Print Contrast:	20% Minimum Reflectance Difference	
Number Characters Read:	Up to 80 Data Characters on 1D; 1850 Text Characters for PDF417	
Beeper Operation:	7 tones or no beep	
Indicators (LED) <i>Default Settings:</i>	Blue	Unit Powered, Ready to Scan
	White	Good Read
	Yellow	In Stand
MECHANICAL		
Height:	183 mm (7.2")	
Width:	Handle	- 30 mm (1.2")
	Head	- 79 mm (3.1")
Depth:	111 mm (4.9")	
Weight:	225 g (8.0 oz)	
Termination:	10 pin modular RJ45	
Cable:	Standard 2.7 m (9') Coiled; Optional 2.1 m (7') Straight	

Specifications are subject to change without notice.

DESIGN SPECIFICATIONS

MS1690 DESIGN SPECIFICATIONS	
ELECTRICAL	
Input Voltage:	5.0VDC \pm 0.25V
Power:	Peak = 2 W (Typical)
	Operating = 1.65 W (Typical)
	Idle / Standby = 800 mW (Typical)
Current:	Peak = 400 mA (Typical)
	Operation = 330 mA (Typical)
	Idle / Standby = 160 mA (Typical)
DC Transformer:	Class 2; 5.2VDC @ 650 mA
EMC:	FCC, ICES-003 & EN55022 Class A
Class 1 LED Product:	IEC 60825-1:1993+A1:1997+A2:2001
ENVIRONMENTAL	
Temperature:	Operating = 0°C to 40° (32° to 104°F)
	Storage = -40°C to 60°C (-40°F to 140°F)
Humidity:	5% to 95% Relative Humidity, Non-Condensing
Light Levels:	Up to 4842 Lux (450 Footcandles)
Shock:	Designed to withstand 1.8 m (6') drops
Contaminants:	Sealed to resist airborne particulate contaminants
Ventilation:	None required

Specifications are subject to change without notice..

APPLICATIONS AND PROTOCOLS

The model number on each scanner includes the scanner number and factory default communications protocol.

SCANNER	VERSION IDENTIFIER	COMMUNICATION PROTOCOL(S)
MS1690 -	11	IBM 468X/469X, RS232-TXD, RXD, RTS, CTS
	14	RS232 (TX, RX, RTS, CTS, DTR)
	38	Low Speed USB
	40	Full-speed USB
	47	Keyboard Wedge, Stand-Alone Keyboard and RS232 Transmit/Receive

The MS1690-47 with a built-in PC Keyboard Wedge Interface is designed for Keyboard emulation use only. Many RS232 configurable functions available in other Metrologic scanners are also available as keyboard wedge functions.

The following are the most important selectable options specific to the keyboard wedge.

Keyboard Type

- **AT (includes IBM® PS2 models 50, 55, 60, 80)
- IBM PS2 (includes models 30, 70, 8556)

Keyboard Country Type

- **USA
- Belgium
- French
- German
- Italian
- Japanese
- Spanish
- Swiss
- United Kingdom

** For additional information on the MS 1690's default settings refer to pages 28-31. For information on how to change the default settings, refer to help files in MetroSet2 or the MetroSelect Single-Line Configuration Guide (MLPN 00-02544).

DEFAULT SETTINGS – COMMUNICATION PARAMETERS

Many functions of the scanner can be “configured” – that is, enabled or disabled. The scanner is shipped from the factory programmed to a set of default conditions. The default parameter of the scanner has an asterisk (*) in the charts on the following pages. If an asterisk is not in the default column then the default setting is OFF or DISABLED. Every interface does not support every parameter. If the interface supports a parameter listed in the charts on the following pages, a check mark (✓) will appear.

PARAMETER	DEFAULT	RS232	IBM 46XX	KBW	USB
Multi-Try Trigger Out-of-Stand	*	✓	✓	✓	✓
Presentation Mode In-Stand	*	✓	✓	✓	✓
Continuous Trigger		✓	✓	✓	✓
Single Trigger		✓	✓	✓	✓
Aiming in Trigger and Continuous Modes	*	✓	✓	✓	✓
Aiming in Presentation Mode		✓	✓	✓	✓
Long-Range In-Stand	*	✓	✓	✓	✓
Short-Range In-Stand		✓	✓	✓	✓
Long-Range Out-of-Stand	*	✓	✓	✓	✓
Short-Range Out-of-Stand		✓	✓	✓	✓
UPC/EAN	*	✓	✓	✓	✓
Code 128	*	✓	✓	✓	✓
Code 93	*	✓	✓	✓	✓
Codabar	*	✓	✓	✓	✓
Interleaved 2 of 5 (ITF)	*	✓	✓	✓	✓
MOD 10 check on ITF		✓	✓	✓	✓
Code 11		✓	✓	✓	✓
Code 39	*	✓	✓	✓	✓
Full ASCII Code 39		✓	✓	✓	✓
PDF	*	✓	✓	✓	✓
Data Matrix		✓	✓	✓	✓
QR Code		✓	✓	✓	✓

DEFAULT SETTINGS – COMMUNICATION PARAMETERS

PARAMETER	DEFAULT	RS232	IBM 46XX	KBW	USB
Maxicode		✓	✓	✓	✓
Aztec		✓	✓	✓	✓
Postals		✓	✓	✓	✓
Mod 43 Check on Code 39		✓	✓	✓	✓
MSI-Plessey 10/10 Check Digit		✓	✓	✓	✓
MSI-Plessey Mod 10 Check Digit	*	✓	✓	✓	✓
Paraf Support ITF		✓	✓	✓	✓
ITF Symbol Lengths	Variable	✓	✓	✓	✓
Symbol Length Lock	None	✓	✓	✓	✓
Beeper tone	Normal	✓	✓	✓	✓
Beep/transmit sequence	Before transmit	✓	✓	✓	✓
Communication timeout	None	✓	✓	✓	✓
Razzberry tone on timeout		✓	✓	✓	✓
Three beeps on timeout		✓	✓	✓	✓
Same symbol rescan timeout: 1000 msec	*	✓	✓	✓	✓
Same symbol rescan timeout configurable in 50 msec steps (maximum of 6.35 sec.)		✓	✓	✓	✓
No Same symbol timeout		✓	✓	✓	✓
Infinite Same symbol timeout		✓	✓	✓	✓
Inter-character delay configurable in 1 msec steps (maximum of 255 msec)	1 msec 10 msec in KBW	✓	✓	✓	✓
Number of scan buffers (<i>maximum</i>)	8	✓	✓	✓	✓
Transmit UPC-A check digit	*	✓	✓	✓	✓
Transmit UPC-E check digit		✓	✓	✓	✓
Expand UPC-E		✓	✓	✓	✓
Convert UPC-A to EAN-13		✓	✓	✓	✓

DEFAULT SETTINGS – COMMUNICATION PARAMETERS

PARAMETER	DEFAULT	RS232	IBM 46XX	KBW	USB
Transmit lead zero on UPC-E		✓	✓	✓	✓
Transmit UPC-A number system	*	✓	✓	✓	✓
Transmit UPC-A Manufacturer ID#	*	✓	✓	✓	✓
Transmit UPC-A Item ID#	*	✓	✓	✓	✓
Transmit Codabar Start/Stop Characters		✓	✓	✓	✓
CLSI Editing (Enable)		✓	✓	✓	✓
Transmit Mod 43 Check digit on Code 39		✓	✓	✓	✓
Transmit Mod 10/ITF		✓	✓	✓	✓
Transmit MSI-Plessey		✓	✓	✓	✓
Parity	No	✓	✓		✓
Baud Rate	9600	✓			
8 Data Bits	*	✓			
7 Data Bits		✓			
Stop Bits	1	✓			
Transmit Sanyo ID Characters		✓		✓	
Nixdorf ID		✓		✓	
LRC Enabled		✓		✓	
UPC Prefix		✓		✓	
UPC Suffix		✓		✓	
Carriage Return	*	✓		✓	
Line Feed-Disabled by default in KBW	*	✓		✓	
Tab Prefix		✓		✓	
Tab Suffix		✓		✓	
"DE" Disable Command		✓			
Enable Command		✓			
DTR Handshaking support		✓			
RTS/CTS Handshaking		✓			
Character RTS/CTS	*	✓			
Message RTS/CTS		✓			

DEFAULT SETTINGS – COMMUNICATION PARAMETERS

PARAMETER	DEFAULT	RS232	IBM 46XX	KBW	USB
XON/XOFF Handshaking		✓			
ACK/NAK		✓			
Two Digit Supplements		✓	✓	✓	✓
Five Digit Supplements		✓	✓	✓	✓
Bookland		✓	✓	✓	✓
977 (2 digit) Supplemental Requirement		✓	✓	✓	✓
Supplements are not Required	*	✓	✓	✓	✓
Two Digit Redundancy	*	✓	✓	✓	✓
Five digit Redundancy		✓	✓	✓	✓
Coupon Code 128		✓	✓	✓	✓
† Configurable Code Lengths	7 avail	✓	✓	✓	✓
† Code Selects with configurable Code Length Locks	3 avail	✓	✓	✓	✓
Configurable Prefix characters	10 avail	✓		✓	
Suffix characters	10 avail	✓		✓	
Prefixes for Individual Code types		✓		✓	
Editing		✓	✓	✓	✓
Function/Control Key Support	*	✓	✓	✓	✓
Omnidirectional Scanning	*	✓	✓	✓	✓
Linear Only Scanning		✓	✓	✓	✓
Linear 1D / Omni 2D		✓	✓	✓	✓

† These options are mutually exclusive. One can not be used in conjunction with the other.

CONFIGURATION MODES

The MS1690 Focus Series has three modes of configuration.

- **Bar Codes**

The MS1690 can be configured by scanning the bar codes included in the Metrologic Single-Line Configuration Guide (MLPN 00-02544). This manual can be downloaded for FREE from Metrologic's website (www.metrologic.com).

- **MetroSet2**

This user-friendly Windows-based configuration program allows you to simply 'point-and-click' at the desired scanner options. This program can be downloaded for FREE from Metrologic' website (www.metrologic.com) or set-up disks can be ordered by calling 1-800-ID-METRO.

- **Serial Programming**

This mode of configuration is ideal for OEM applications. This mode gives the end-user the ability to send a series of commands using the serial port of the host system. The commands are equivalent to the numerical values of the bar codes located in the MetroSelect Single-Line Configuration Guide (MLPN 00-02544).

UPGRADING THE FLASH ROM FIRMWARE

The MetroSet2 program is a functional component of Metrologic's new line of Flash-based scanners. This program allows the user of a Metrologic scanner to quickly upgrade to a new or custom version of firmware. It requires the use of a personal computer running Windows 95 or greater and the use of a serial port. The user merely connects the scanner to a serial port on the PC, launches the MetroSet2 program, and blasts off to new software upgrades.

Each MS1690, regardless of the version number or communication protocol, can be upgraded. In other words, all RS232 (-14), keyboard wedge (-47), IBM 468X/469X (-11), low speed USB (-38), and full speed USB (-40) units can be upgraded. To upgrade all units, a power supply and PowerLink cable (MLPN 54-54014) are required.



RS232 units can be upgraded using the standard PowerLink cable (MLPN 53-53xxx-3).

The program guides the user with its simplistic one click approach. The user must first select the file. Once the file is selected and verified, the scanner is ready to be upgraded. Press the "Flash Scanner" button to upgrade the scanner. The unit will go into a "flash mode" – the blue and white LEDs will be flashing alternately. The user can follow the progress of the upgrade by watching the screen for details. When the upgrade is complete, the scanner will reset itself. If a razz/beep occurs, the scanner did not upgrade properly. Contact a Metrologic service representative for additional assistance.

SCANNER AND CABLE TERMINATIONS

Scanner Pinout Connections

The MS1690 scanner interfaces terminate to a 10-pin, RJ45 Female Socket. The serial # label indicates the interface enabled when the scanner is shipped from the factory.

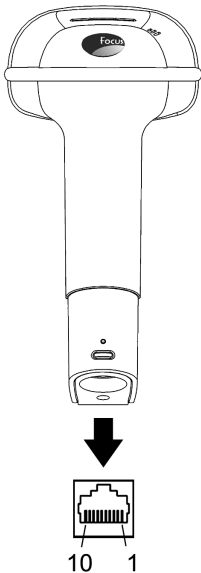

Figure 18.

MS1690-14, RS232	
Pin	Function
1	Ground
2	RS232 Transmit Output
3	RS232 Receive Input
4	RTS Output
5	CTS Input
6	DTR Input
7	Reserved
8	Reserved
9	+5VDC
10	Shield Ground

MS1690-47, Keyboard Wedge & Stand-Alone Keyboard	
Pin	Function
1	Ground
2	RS232 Transmit Output
3	RS232 Receive Input
4	PC Data
5	PC Clock
6	KB Clock
7	PC +5V
8	KB Data
9	+5VDC
10	Shield Ground

MS1690-11, IBM 468X/469X	
Pin	Function
1	Ground
2	RS232 Transmit Output
3	RS232 Receive Input
4	RTS Output
5	CTS Input
6	Reserved
7	IBM B-Transmit
8	IBM A+ Receive
9	+5VDC
10	Shield Ground

Scanner Pinout Connections

MS1690-38, Low Speed USB	
Pin	Function
1	Ground
2	RS232 Transmit Output
3	RS232 Receive Input
4	RTS Output
5	CTS Input
6	USB D+
7	V USB
8	USB D-
9	+5VDC
10	Shield Ground

MS1690-40, Full Speed USB	
Pin	Function
1	Ground
2	RS232 Transmit Output
3	RS232 Receive Input
4	RTS Output
5	CTS Input
6	USB D+
7	V USB
8	USB D-
9	+5VDC
10	Shield Ground

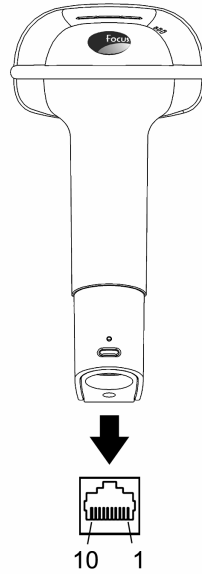
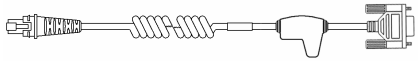
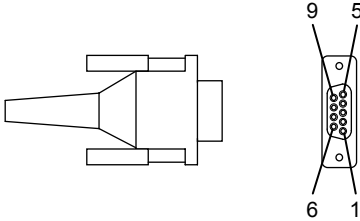
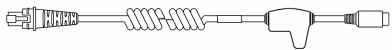
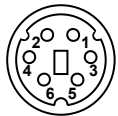

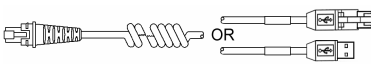

Figure 19.

SCANNER AND CABLE TERMINATIONS

Cable Connector Configurations (Host End)



"Standard" PowerLink Cable 53-53000-3 Coiled		
Pin	Function	 <p style="text-align: center;">9-Pin D-Type Connector</p>
1	Shield Ground	
2	RS232 Transmit Output	
3	RS232 Receive Input	
4	DTR Input/Light Pen Source	
5	Power/Signal Ground	
6	Reserved	
7	CTS Input	
8	RTS Output	
9	+5VDC	

Stand Alone Keyboard PowerLink Cable 53-53020-3		
Pin	Function	 <p style="text-align: center;">6-Pin Male Mini-DIN Connector</p>
1	PC Data	
2	NC	
3	Power Ground	
4	+5VDC PC Power to KB	
5	PC Clock	
6	NC	

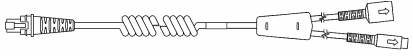

USB Power/Communication Cable 53-53213-N-3, 53-53214-N-3 or 53-53235-N-3			
Pin	Function	 <p style="text-align: center;">USB Type A Locking with Power</p>	 <p style="text-align: center;">USB Non-Locking</p>
1	PC +5V/V_USB		
2	D-		
3	D+		
4	Ground		
Shield	Shield		

SCANNER AND CABLE TERMINATIONS

Cable Connector Configuration (Host End)

Keyboard Wedge PowerLink Cable <i>53-53002-3 Coiled</i>		
Pin	Function	 <p>5-Pin DIN, Female</p>
1	Keyboard Clock	
2	Keyboard Data	
3	No Connect	
4	Power Ground	
5	+5 VDC	 <p>6-Pin DIN, Male</p>
Pin	Function	
1	PC Data	
2	No Connect	
3	Power Ground	
4	+5 VDC	
5	PC Clock	
6	No Connect	

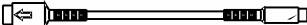
Metrologic will supply an adapter cable with a 5-pin DIN male connector on one end and a 6-pin mini DIN female connector on the other. According to the termination required, connect the appropriate end of the adapter cable to the PowerLink cable, leaving the necessary termination exposed for connecting to the keyboard and the keyboard port on the PC.

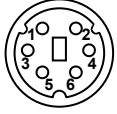
Keyboard Wedge Adapter Cable		
Pin	Function	 <p>5-Pin DIN, Male</p>
1	PC Clock	
2	PC Data	
3	No Connect	
4	Power Ground	
5	+5 VDC	 <p>6-pin Mini DIN, Female</p>
Pin	Function	
1	Keyboard Data	
2	No Connect	
3	Power Ground	
4	+5 VDC	
5	Keyboard Clock	
6	No Connect	

LIMITED WARRANTY

The MS1690 Focus™ scanners are manufactured by Metrologic at its Blackwood, New Jersey, U.S.A. facility. The MS1690 Focus scanners have a five (5) year limited warranty from the date of manufacture. Metrologic warrants and represents that all MS1690 Focus scanners are free of all defects in material, workmanship and design, and have been produced and labeled in compliance with all applicable U.S. Federal, state and local laws, regulations and ordinances pertaining to their production and labeling.

This warranty is limited to repair, replacement of product or refund of product price at the sole discretion of Metrologic. Faulty equipment must be returned to one of the following Metrologic repair facilities: Blackwood, New Jersey, USA; Madrid, Spain; or Suzhou, China. To do this, contact the appropriate Metrologic Customer Service/Repair Department to obtain a Returned Material Authorization (RMA) number.

In the event that it is determined the equipment failure is covered under this warranty, Metrologic shall, at its sole option, repair the Product or replace the Product with a functionally equivalent unit and return such repaired or replaced Product without charge for service or return freight, whether distributor, dealer/reseller, or retail consumer, or refund an amount equal to the original purchase price.

This limited warranty does not extend to any Product which, in the sole judgment of Metrologic, has been subjected to abuse, misuse, neglect, improper installation, or accident, nor any damage due to use or misuse produced from integration of the Product into any mechanical, electrical or computer system. The warranty is void if the case of Product is opened by anyone other than Metrologic's repair department or authorized repair centers.

THIS LIMITED WARRANTY, EXCEPT AS TO TITLE, IS IN LIEU OF ALL OTHER WARRANTIES OR GUARANTEES, EITHER EXPRESS OR IMPLIED, AND SPECIFICALLY EXCLUDES, WITHOUT LIMITATION, WARRANTIES OF MERCHANTABILITY AND FITNESS FOR A PARTICULAR PURPOSE UNDER THE UNIFORM COMMERCIAL CODE, OR ARISING OUT OF CUSTOM OR CONDUCT. THE RIGHTS AND REMEDIES PROVIDED HEREIN ARE EXCLUSIVE AND IN LIEU OF ANY OTHER RIGHTS OR REMEDIES. IN NO EVENT SHALL METROLOGIC BE LIABLE FOR ANY INDIRECT OR CONSEQUENTIAL DAMAGES, INCIDENTAL DAMAGES, DAMAGES TO PERSON OR PROPERTY, OR EFFECT ON BUSINESS OR PROPERTY, OR OTHER DAMAGES OR EXPENSES DUE DIRECTLY OR INDIRECTLY TO THE PRODUCT, EXCEPT AS STATED IN THIS WARRANTY. IN NO EVENT SHALL ANY LIABILITY OF METROLOGIC EXCEED THE ACTUAL AMOUNT PAID TO METROLOGIC FOR THE PRODUCT. METROLOGIC RESERVES THE RIGHT TO MAKE ANY CHANGES TO THE PRODUCT DESCRIBED HEREIN.

CORPORATE HEADQUARTERS, NORTH AMERICA

Metrologic Instruments, Inc.

90 Coles Rd.
Blackwood, NJ 08012-4683
Customer Service Department
Tel: 1-800-ID-METRO
Fax: 856-228-6673
Email: info@metrologic.com

METROLOGIC EUROPEAN REPAIR CENTER (MERC)

Metrologic Eria Ibérica, SL

C/Alfonso Gomez, 38-40, 1D
28037 Madrid
Tel: +34 913 751 249
Fax: +34 913 270 437

MTLG AUTO ID INSTRUMENTS (SHANGHAI) CO., LTD

Suzhou Sales Office

BLK A, Room# 03/03-04
No.5 Xinghan Street, Xinsu Industrial Square
China-Singapore Suahou Industrial Park, Suzhou, PRC
Tel: 86-512-67622550
Fax: 86-512-67622560
Email: info@cn.metrologic.com

Notices

This equipment has been tested and found to comply with limits for a Class A digital device, pursuant to part 15 of the FCC Rules. These limits are designed to provide reasonable protection against harmful interference when the equipment is operated in a commercial environment. This equipment generates uses, and can radiate radio frequency energy and, if not installed and used in accordance with the instruction manual, may cause harmful interference to radio communications. Operation of this equipment in a residential area is likely to cause harmful interference, in which case the user will be required to correct the interference at his own expense. Any unauthorized changes or modifications to this equipment could void the users' authority to operate this device.

This device complies with part 15 of the FCC Rules. Operation is subject to the following two conditions: (1) This device may not cause harmful interference, and (2) this device must accept any interference received, including interference that may cause undesired operation.

Notice

This Class A digital apparatus complies with Canadian ICES-003.

Remarque

Cet appareil numérique de la classe A, conformément à la norme NMB-003 du Canada.



⚠ Caution

Use of controls or adjustments or performance of procedures other than those specified herein may result in hazardous radiation exposure. Under no circumstances should the customer attempt to service the LED scanner. Never attempt to look at the LED beam, even if the scanner appears to be nonfunctional. Never open the scanner in an attempt to look into the device. Doing so could result in hazardous radiation exposure. The use of optical instruments with the LED equipment will increase eye hazard.

⚠ Atención

La modificación de los procedimientos, o la utilización de controles o ajustes distintos de los especificados aquí, pueden provocar una exposición de luz brillante peligrosa. Bajo ninguna circunstancia el usuario deberá realizar el mantenimiento del LED (Diodo Emisor de Luz) del lector. Ni intentar mirar al haz del LED incluso cuando este no esté operativo. Tampoco deberá abrir el lector para examinar el aparato. El hacerlo puede conllevar una exposición peligrosa a la luz del LED. El uso de instrumentos ópticos con el equipo LED puede incrementar el riesgo para la vista.

⚠ Attention

L'emploi de commandes, réglages ou procédés autres que ceux décrits ici peut entraîner de graves irradiations. Le client ne doit en aucun cas essayer d'entretenir lui-même le scanner ou la LED. Ne regardez jamais directement le rayon LED, même si vous croyez que le scanner est inactif. N'ouvrez jamais le scanner pour regarder dans l'appareil. Ce faisant, vous vous exposez à un risque d'irradiation. L'emploi d'appareils optiques avec cet équipement à LED augmente le risque d'endommagement de la vision.

⚠ Achtung

Die Verwendung anderer als der hier beschriebenen Steuerungen, Einstellungen oder Verfahren kann eine gefährliche Licht emittierender Dioden strahlung hervorrufen. Der Kunde sollte unter keinen Umständen versuchen, den Licht emittierender Dioden-Scanner selbst zu warten. Sehen Sie niemals in den Licht emittierender Diodenstrahl, selbst wenn Sie glauben, daß der Scanner nicht aktiv ist. Öffnen Sie niemals den Scanner, um in das Gerät hineinzusehen. Wenn Sie dies tun, können Sie sich einer gefährlichen Licht emittierender Diodenstrahlung aussetzen. Der Einsatz optischer Geräte mit dieser Laserausrüstung erhöht das Risiko einer Sehschädigung.

⚠ Attenzione

L'utilizzo di sistemi di controllo, di regolazioni o di procedimenti diversi da quelli descritti nel presente Manuale può provocare delle rischiose esposizioni radiattive. Il cliente non deve assolutamente tentare di riparare egli stesso lo scanner LED (o diodo emettitore di luce). Non guardate mai il raggio LED (d. emettitore di luce), anche se credete che lo scanner non sia attivo. Non aprite mai lo scanner per guardare dentro l'apparecchio. Facendolo potete esporvi ad una radiazione rischiosa. L'uso di apparecchi ottici, equipaggiati con raggi LED (d. emettitori di luce), aumenta il rischio di danni alla vista.

PATENTS

Worldwide Patents Pending

INDEX

A

AC2, 7–11, 26
Accessories2
Adapter2, 37
Aperture4
Audible Indicator17–18, 33

B

Bar Code 21–24, 25, 32
Bar Code Element19
Beep 17–18, 21–24, 25, 33
Blue LED 4, 7–11, 17–18, 33

C

Cable3
 IBM10
 Keyboard Wedge8, 36–37
 MVC3
 PowerLink 2, 5, 7–11, 21–24,
 33, 36–37
 RS2327, 36–37
 Stand Alone Keyboard ...9, 36–37
 USB11, 36–37
Caution 7–11, 39–40
CE6, 7–11, 40
Class39
CodeGate1, 4, 15
Communication Parameters ..28–31
Compliance 7–11, 38, 39–40
Configuration... 2, 21–24, 27, 32, 33
Connector Pinouts34–35
Converter11
Current26
Customer Service2, 3, 38

D

DC 2, 26, 34–35, 36–37
Decode25
Default Parameters27, 28–31
 IBM28–31
 Keyboard Wedge28–31
 RS23228–31
 Stand Alone Keyboard28–31
 USB28–31

Depth of Field 19

E

EMC26

F

Firmware33
Flash ROM33

H

Host5, 7–11

I

Indicator
 Audible4, 17–18, 25, 33
 Failure4, 17–18
 Visual4, 17–18, 25, 33
Interface21–24, 25
 Cable7–11, 36–37
 IBM1, 3, 10, 27, 28–31, 34–35
 Keyboard Wedge 1, 2, 8, 27,
 28–31, 34–35
 RS232 1, 2, 7, 27, 28–31,
 34–35
 Stand Alone Keyboard1, 2, 9,
 27, 28–31, 34–35
 USB1, 3, 11, 27, 28–31,
 34–35
IR 1, 15, 20

K

Keyboard Country Type27
Keyboard Type27
Keyboard Wedge2

L

Labels6
LED7–11, 21–24, 25, 39–40
 Blue7–11, 17–18
 White7–11, 17–18
 Yellow7–11, 17–18
Light Levels26
Light Source25

INDEX

M

Maintenance	6
Meteor	33
MetroSelect	16, 27, 32
MetroSet2	33
Mode of Operation	15

N

Notices	39
---------------	----

P

Patent	41
PDF	19
Pinouts	34–35, 36–37
Power	7–11, 26, 33
Power Supply	5, 7–11
PowerLink	4
Presentation	15
Product Safety	39–40
Protocols	27

R

Razz	17–18, 21–24
Repair	38
RMA	38
RS232	2

S

SELV	7–11
Service	38
Specifications	
Electrical	26
Environmental	26
Mechanical	25
Operational	25

Stand	3, 12–14, 15
Stand Alone Keyboard	2
Swiftdecoder™	1

T

Tone	17–18
Alternate	16
Transformer	2, 7–11, 26
Trigger	4
Troubleshooting	21–24

U

UL	6, 7–11
Upgrade	33
USB	
Full Speed	1, 3, 11, 27, 28–31, 34–35
Low Speed	1, 3, 11, 27, 28–31, 34–35

V

Ventilation	26
Visual Indicator	17–18, 33
Voltage	26

W

Warranty	38
White LED	4, 7–11, 17–18, 33
Window	4, 6

Y

Yellow LED	4, 7–11, 17–18
------------------	----------------

CONTACT INFORMATION AND OFFICE LOCATIONS

Worldwide Headquarters

Metrologic Instruments, Inc.

90 Coles Road • Blackwood, NJ 08012-4683 • Email: info@metrologic.com
Tel: 856-228-8100 • Fax: 856-228-6673 (Sales) • Fax: 856-228-1879 (Marketing) • Fax: 856-228-0653 (Legal/Finance)

Asia (AS)

HQ – Singapore

Metrologic Asia (Pte) Ltd
50 Kallang Avenue #01-02
Noel Corporate Building
Singapore 339505
Tel: (65) 6842-7155
Fax: (65) 6842-7166
Email: info@sg.metrologic.com

China

MTLGO Auto ID Instruments (Shanghai) Co., Ltd
Room 1419, No. 1 Ji long Rd
Waigaoqiao Bonded Zone
Shanghai 200000
Tel: 86-21-58692780
Fax: 86-21-58692782
Email: info@cn.metrologic.com

China

Suzhou Sales Office
BLK A, Room# 03/03-04
No.5 Xinghan Street,
Xinsu Industrial Square
China-Singapore
Suzhou Industrial Park,
Suzhou, PRC
Tel: 86-512-67622550
Fax: 86-512-67622560
Email: info@cn.metrologic.com

China

Guangzhou Sales Office
Room 2307
Foreign Economic and Trade Bldg
#351 Tianhe Road
Guangzhou City,
Guangdong Province, PRC
Tel: 86-20-38823476
Fax: 86-20-38823477
Email: info@cn.metrologic.com

China

Chengdu Sales Office
C-3 16th Floor Chuanxin Mansion
Section 2 of South People's Road
Chengdu City Sichuan Province
PRC 610016
Tel/Fax: 86 28 862004109
Email: info@cn.metrologic.com

India

India Sales Office
703, 6th floor, Oxford Towers 139
Airport Road Bangalore
India 560008
Tel: +91 80 51256718
Fax: +91 80 51256719
Email: info@in.metrologic.com

Indonesia

Metrologic Indonesia
J.L. Puter II Blok ED 2 No. 6
Bintaro Jaya Sektor 5
Jakarta Selatan, Indonesia
Tel: 62 21 7360682
Fax: 62 21 7360682
Email: a.herdian@id.metrologic.com

Europe, Middle East & Africa (EMEA)

HQ – Puchheim, Germany

Metrologic Instruments GmbH
Dornierstrasse 2
82178 Puchheim
Munich, Germany
Tel: 49-89-89019-0
Fax: 49-89-89019-200
Email: info@europa.metrologic.com

France

Metrologic Eria France SA
69 Rue de la Belle Etoile
21 Paris Nord II, BP 50057
95947- ROISSY CDG CEDEX
Tel: +33 (0) 1 48.63.78.78
Fax: +33 (0) 1 48.63.24.94
Email: info@fr.metrologic.com

Italy

Metrologic Instruments Italia
Via Emilia 70
40064 Ozzano dell'Emilia (BO)
Tel: +39 0 57 6511978
Fax: +39 0 51 6521337
Email: info@it.metrologic.com

Poland

Metrologic Instruments Poland
Poleczki 21
02-822 Warsaw, Poland
Tel: +48 (22) 545 04 30
Fax: +48 (22) 545 04 31
Email: info@pl.metrologic.com

Russia

Metrologic Russia
Bolshaya Novodmitrovskaya 14
RU-125015
Moscow Russia
Tel: +7 095 730 7424
Fax: +7 095 730 7425
Email: info@ru.metrologic.com

Spain

Metrologic eria Iberica, SL
Julian Camarillo 29, D-1
28037 Madrid
Tel: +34 913 272 400
Fax: +34 913 273 829
Email: info@es.metrologic.com

United Kingdom

Metrologic Instruments UK Limited
58 Tempus Business Centre
Kingsclere Road, Basingstoke
Hampshire RG21 6XG
Tel: +44 (0) 1256 365900
Fax: +44 (0) 1256 365955
Email: info@uk.metrologic.com

Taiwan

Taiwan Sales Office
8F, No 17, Lane 160,
Section 1 Xingsheng South Road
Taipai Taiwan
Tel: 886-2-23510125
Email: john.cheng@tw.metrologic.com

The Americas (TA)

HQ – New Jersey, USA

Metrologic The Americas
1571 Imperial Way Suite B
West Deptford, NJ 08066
Tel: 1.856.537.6400
Fax: 1.856.537.6474
Email: info@us.metrologic.com

Canada

Metrologic Canada
65 International Blvd, Suite #207
Etobicoke, Ontario M9W 6L9
Tel: 416.752.7190
Fax: 416.752.8060
Email: info@ca.metrologic.com

Mexico

Metrologic Mexico, S.A. DE C.V.
Planta Sta. Rosa # 17
Col. Electra
Tlanepantla, Mexico 54060
Tel: 55.5365.6247
Fax: 55.5362.2544
Email: info@mx.metrologic.com

South America

Metrologic do Brasil Ltda.
Rua da Faz 2059
CEP 04713-002
Chacara Santo Antonio
Sao Paulo, SP, Brasil
Tel: 55.11.5182.7273
Fax: 55.11.5182.7198
Email: info@sa.metrologic.com

South America

Metrologic South America
90 South Seas Court
Marco Island, FL 34145
Tel: 239.642.1958
Fax: 239.642.1959
Cell: 239.248.4541
Email: info@sa.metrologic.com

Japan

Metrologic Japan Co., Ltd.

Matsumoya Building, 6 Floor
3-14-8 Higashiueno
Taitou-ku, Tokyo 110-0015
Japan
Tel: 81-3-3839-8511
Fax: 81-3-3839-8519
Email: info@jp.metrologic.com

Korea

Korea Sales Office
Suite 304, Sinsa Bldg.
3F, 3-1, Nonhyeon-Dong
Kangnam-Gu Seoul,
South Korea 135811
Tel: 82-2-3444-7363/82-1193635379
Fax: 82-2-3444-3980
Email: Scott.lee@kr.metrologic.com

Metrologic Companies

Adaptive Optics Associates (AOA)

Ten Wilson Road
Cambridge, MA 02138-1128
Tel: 617-806-1400
Fax: 617-806-1899
Email: info@aoainc.com

Omniplanar

1571 Imperial Way, Suite A
West Deptford, NJ
Tel: 856.537.6100
Fax: 856.537.6116
Email: info@omniplanar.com

Metrologic European Repair Center (MERC)

Metrologic Eria Iberica, SL
C/ Alfonso Gomez
38-40, 1D28037 Madrid
Tel: +34 913 751 249
Fax: +34 913 270 437
Email: merc@europe.metrologic.com

September 2005

Printed in the USA



00 - 02098C