

Chapter 5

Installation

This chapter describes the procedure and cautions for the installation of the BL-600 Series and special power supply unit.

5.1	Installation of the BL-600 Series	72
5.1.1	Situations to check for before installing the BL-600 Series ...	72
5.1.2	Mounting angle and distance	74
5.1.3	Mounting the BL-600/601/600HA/601HA	75
5.1.4	Mounting the BL-650HA/651HA	77
5.1.5	Mounting the BL-600 Series without the mounting bracket ...	79
5.2	Installation of the Special Power Supply Unit	81
5.2.1	In-panel installation	81
5.2.2	Installing the BL-U1	81
5.2.3	Installing the BL-U2 and N-42	83

5.1 Installation of the BL-600 Series

This section describes situations to check for before installing the BL-600 Series, and the installation procedure.

5.1.1 Situations to check for before installing the BL-600 Series

Check the following points before installing the BL-600 Series.

Avoid extraneous light from entering the transmitter/receiver of the BL-600 Series. Otherwise, the reading may fail or be unreliable.

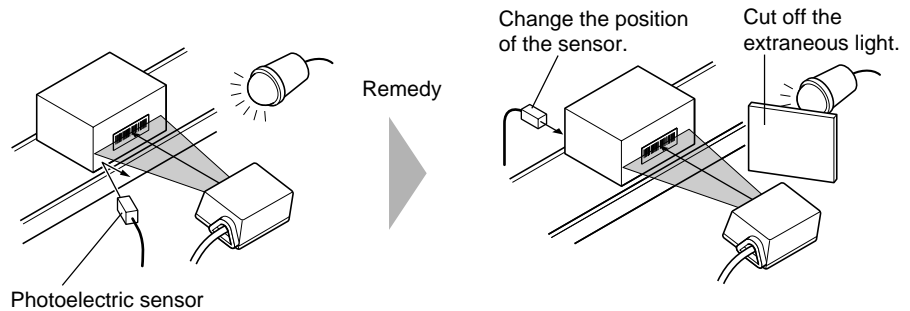

If something interrupts the emitted or reflected laser beam, the reading may be unreliable.

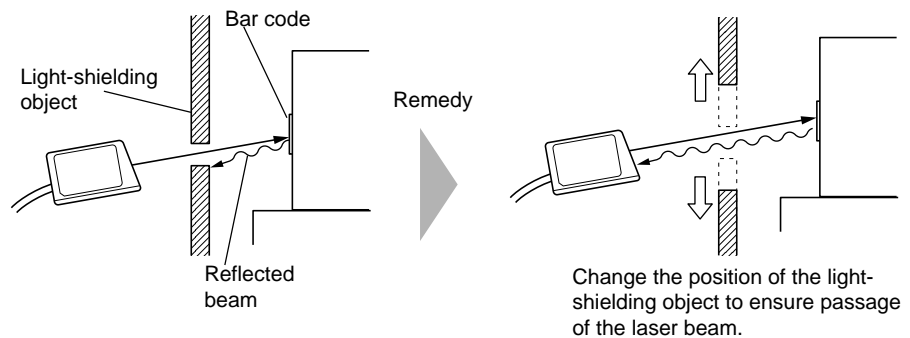

If the laser beam reflects the bar code at a right angle (specular reflection), the reading may fail or be unreliable.

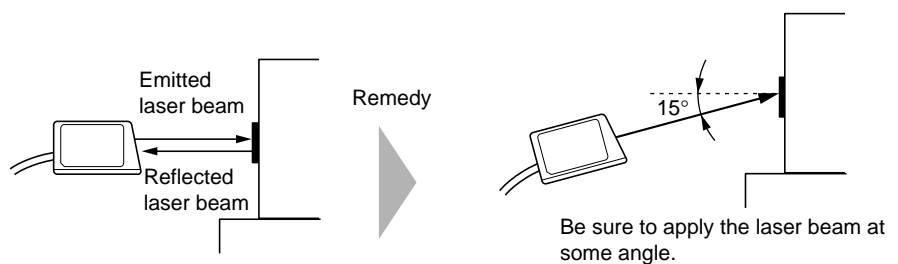

* Since the BL-650HA/651HA emits a laser beam at an angle of 17°, tilting the unit is unnecessary.

If a strong reflected light enters the receiver of the BL-600 Series, the reading may fail or be unreliable.

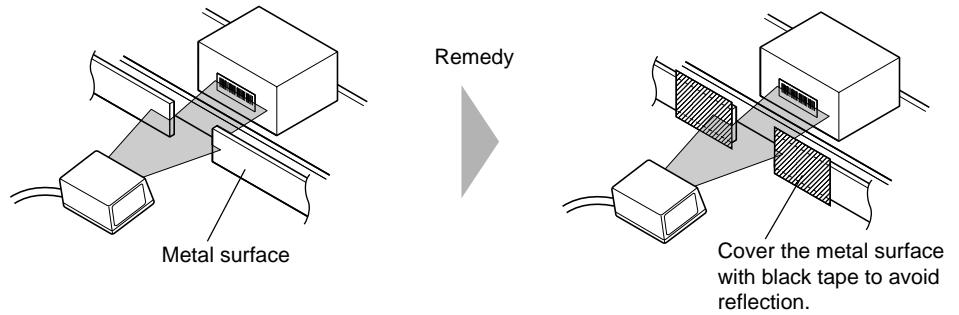

If reflected light enters the receiver of another unit, the reading may be unreliable, because of mutual interference.

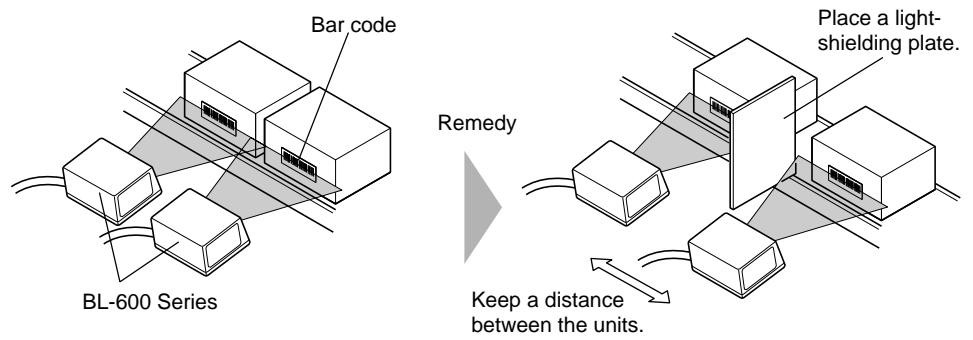

If two or more bar code labels enter the laser beam at the same time, the BL-600 cannot be set to read a specific bar code.

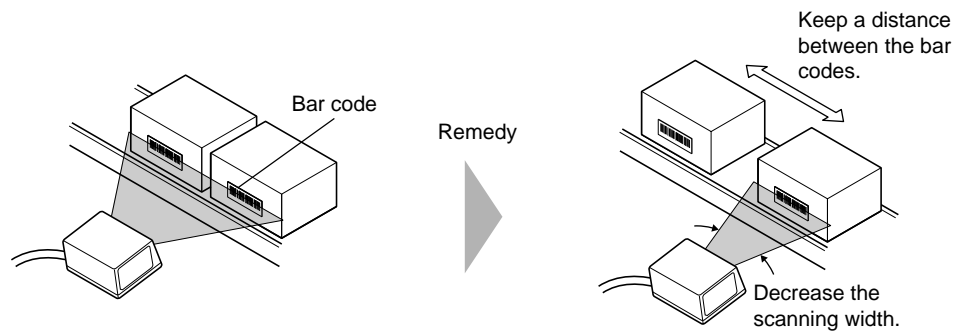

◇ See page 67 to change the scanning width.

* When "Multi-label read mode 3" is specified, the BL-600 Series can simultaneously read up to 4 bar codes in the field of the laser beam.

5.1.2 Mounting angle and distance

The BL-600 Series must be installed so that the laser beam is applied at an angle of approximately 15° with reference to a line perpendicular to the target. This means that the BL-600/601/600HA/601HA must be tilted at an angle of 15° . Since the BL-650HA/651HA emits a laser beam at an angle of 17° , tilting the unit is unnecessary.

Refer to the read range and angle characteristics on pages 148 to 150 for the appropriate mounting angle and distance for the BL-600 Series.

Normally, the BL-600 Series provides the best reading stability when mounted at the following angle and distance.

BL-600/601/600HA/601HA

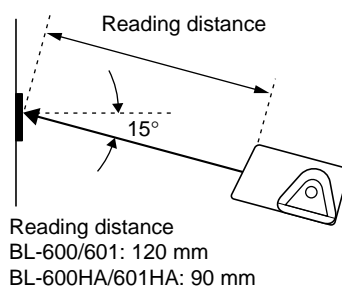

BL-650HA/651HA

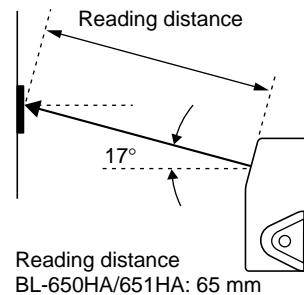

- * The supplied mounting bracket facilitates the angle setting. (⇒ See pages 75 to 78.)
- * The reading rate check mode (⇒ See pages 94 to 96.) ensures an optimal reading position.
- * The laser beam application angle for the BL-650HA/651HA is $17^\circ \pm 3^\circ$ with reference to a line perpendicular to the rear surface of the unit.

Note 1: Do not mount the BL-600 Series so that the laser beam is applied to bar codes at a right angle ($\pm 10^\circ$). Otherwise, the specular reflections may cause unstable reading or reading errors. (⇒ See page 151.)

BL-600/601/600HA/601HA

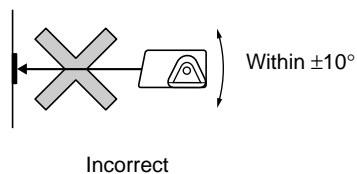

BL-650HA/651HA

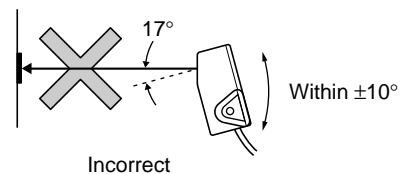

Note 2: The reading distance and angle may vary depending on the narrow bar width, size, and printing quality of bar codes. Be sure to test the BL-600 Series' ability to read the actual bar codes using "Reading rate check mode" on pages 94 to 96.

5.1.3 Mounting the BL-600/601/600HA/601HA

The following is the procedure for mounting the BL-600/601/600HA/601HA with the supplied mounting bracket. To mount the BL-600 Series without the mounting bracket, refer to "Mounting the BL-600 Series without the mounting bracket" on pages 79 and 80.

1. Check the surroundings of the mounting position.

Check the surroundings according to "Situations to check for before installing the BL-600 Series" on pages 72 and 73.

2. Attach the BL-600 Series to the mounting bracket.

⇒ Refer to page 155 for the dimensions of the mounting bracket.

When bracket A is used

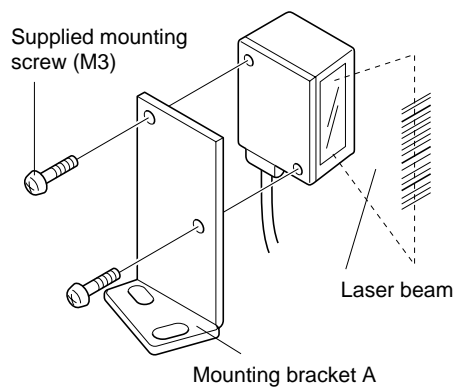

When bracket B is used

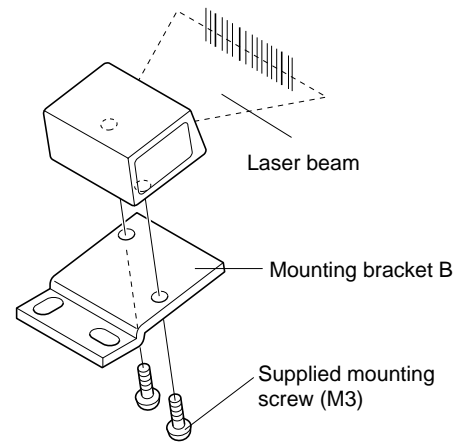

3. Temporarily fix the mounting bracket.

The angle of the laser beam application is 15° when the BL-600 Series is secured to the mounting bracket as shown below.

⇒ See "5.1.2 Mounting angle and distance" on page 74 for the mounting distance.

When mounting bracket A is used:

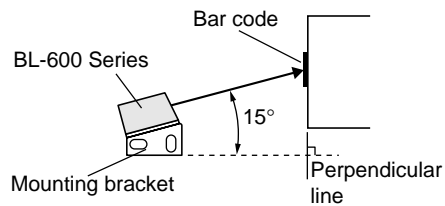

When mounting bracket B is used:

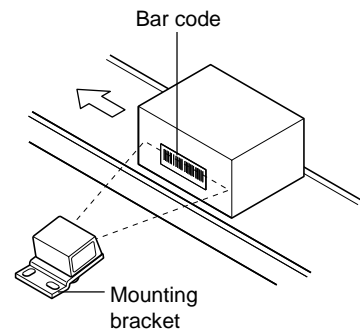
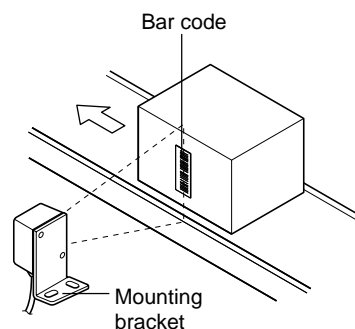
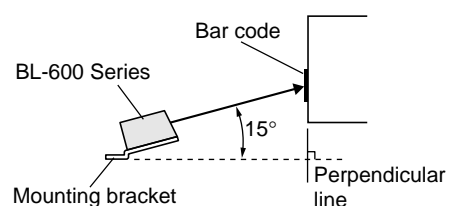

4. Check the reliability of the bar code reading using the Test mode.
Check the reliability of the bar code reading using "Reading rate check mode".
☞ See pages 94 to 96.
5. Check the surroundings and adjust the mounting distance and angle.
If the bar code reading is unreliable, check/adjust the position again by referring to "5.1.1 Situations to check for before installing the BL-600 Series" on pages 72 and 73 and "5.1.2 Mounting angle and distance" on page 74.
6. Fasten the mounting bracket.
 - * Mounting screws (M4) are not included.
 - * To suppress the noise conveyed through the mounting bracket, be sure to use insulating spacers.

When bracket A is used

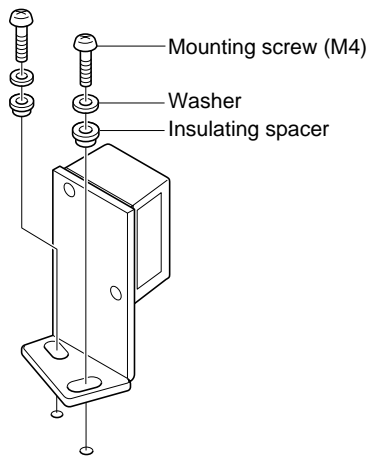

When bracket B is used

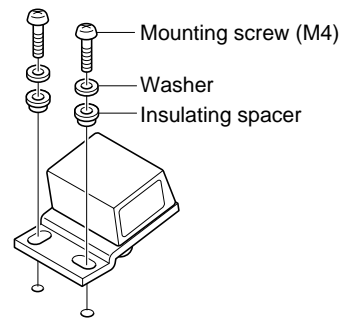

5.1.4 Mounting the BL-650HA/651HA

The following is the procedure for mounting the BL-650HA/651HA with the supplied mounting bracket. To mount the BL-600 Series without the mounting bracket, refer to “Mounting the BL-600 Series without the mounting bracket” on page 79.

1. Check the surroundings of the mounting position.

Check the surroundings according to “5.1.1 Situations to check for before installing the BL-600 Series” on pages 72 and 73.

2. Attach the BL-600 Series to the mounting bracket.

* The mounting bracket for the BL-650HA/651HA allows two mounting orientations. Choose the appropriate orientation according to the application.

◇ Refer to page 155 for the dimensions of the mounting bracket.

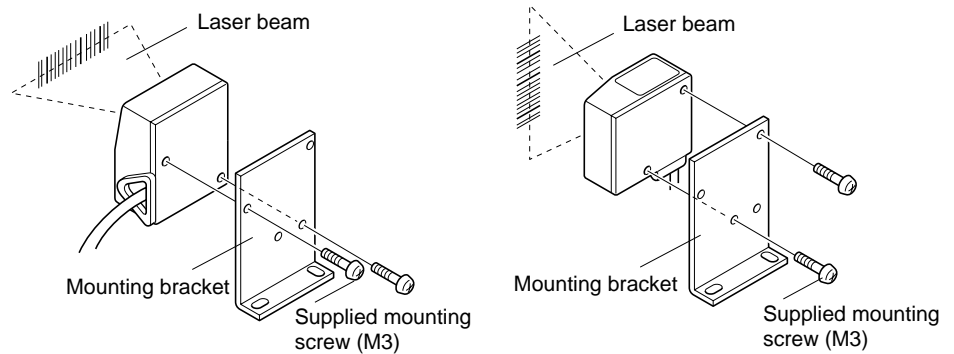

3. Temporarily fix the mounting bracket.

Since the BL-650HA/651HA emits a laser beam at an angle of 17° , install the unit parallel to the surface of the bar code as shown below.

◇ See “5.1.2 Mounting angle and distance” on page 74 for the mounting distance.

* The laser beam application angle for the BL-650HA/651HA is $17^\circ \pm 3^\circ$ with reference to a line perpendicular to the rear surface of the unit.

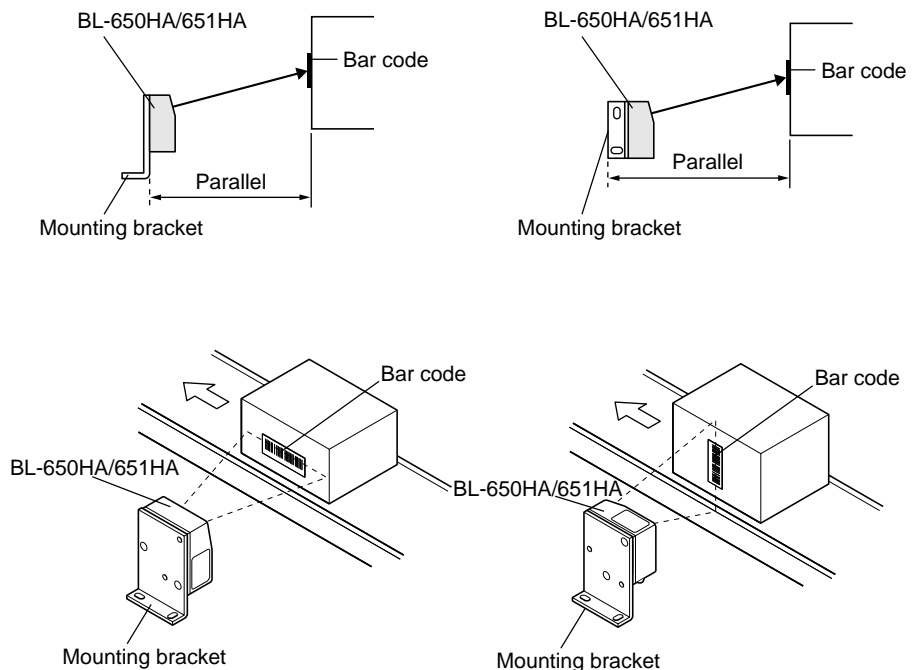

4. Check the reliability of the bar code reading using the Test mode.

Check the reliability of the bar code reading using “6.4.1 Reading rate check mode”. ↪ See pages 94 to 96.

5. Check the surroundings and adjust the mounting distance and angle.

If the bar code reading is unreliable, check/adjust the position again by referring to “5.1.1 Situations to check for before installing the BL-600 Series” on pages 72 and 73 and “5.1.2 Mounting angle and distance” on page 74.

6. Fasten the mounting bracket.

- * Mounting screws (M4) are not included.
- * To suppress the noise conveyed through the mounting bracket, be sure to use insulating spacers.

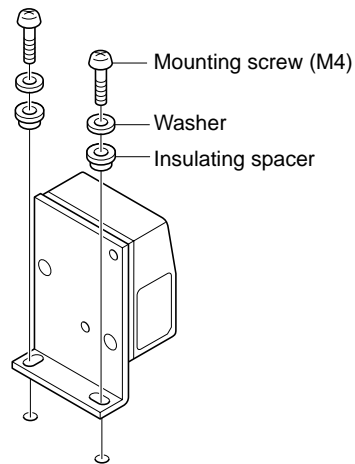

5.1.5 Mounting the BL-600 Series without the mounting bracket

1. Check the surroundings of the mounting position.

Check the surroundings according to “5.1.1 Situations to check for before installing the BL-600 Series” on pages 72 and 73.

2. Temporarily mount the BL-600 Series in position.

The BL-600 Series must be installed so that laser beam is applied at an angle of approximately 15° with reference to a line perpendicular to the target. This means that the BL-600/601/600HA/601HA must be titled at an angle of 15° . Since the BL-650HA/651HA emits a laser beam at an angle of 17° , tilting the unit is unnecessary.

Mount the BL-600 Series in the following orientation according to the laser beam orientation to be used.

BL-600/601/600HA/601HA

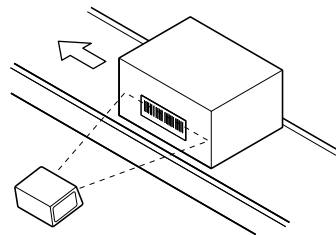
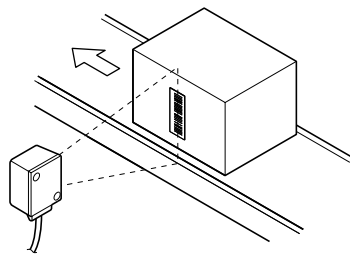

BL-650HA/651HA

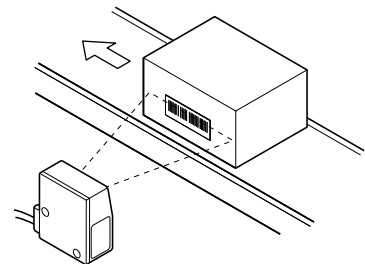
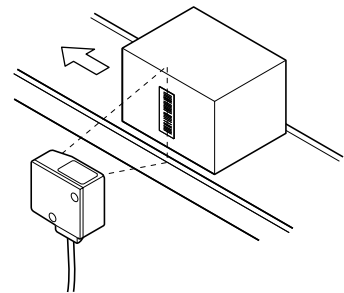

⇨ See “5.1.2 Mounting angle and distance” on page 74 for the mounting distance.

* The laser beam application angle for the BL-650HA/651HA is $17^\circ \pm 3^\circ$ with reference to a line perpendicular to the rear surface of the unit.

3. Check the reliability of the bar code reading using the Test mode.

Check the reliability of the bar code reading using “Reading rate check mode”.

⇨ See pages 94 to 96.

4. Check the surroundings and adjust the mounting distance and angle.

If the bar code reading is unreliable, check/adjust the position again by referring to “5.1.1 Situations to check for before installing the BL-600 Series” on pages 72 and 73 and “5.1.2 Mounting angle and distance” on page 74.

5. Fasten the BL-600 Series.

Fasten the BL-600 Series in the mounting position with M3 screws.

* The M3 screws are not included. Select the M3 screws after checking the panel thickness and other factors of the mounting position. (The mounting hole for the BL-600 Series is 4 mm deep.)

BL-600/601/600HA/601HA

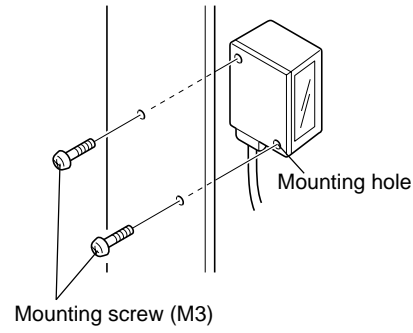

BL-650HA/651HA

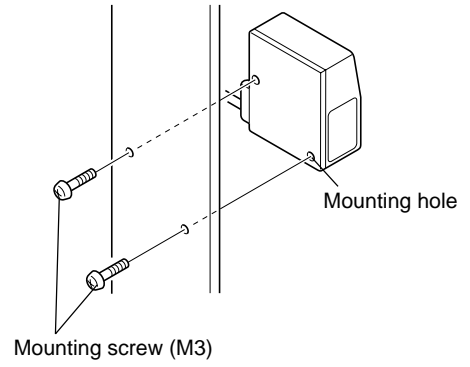

5.2 Installation of the Special Power Supply Unit

This section describes how to install the special power supply units BL-U1, BL-U2, and N-42.

5.2.1 In-panel installation

To mount the power supply unit BL-U1, BL-U2 or N-42, carefully observe the following instructions.

- Provide enough ventilation space.
- If the ambient temperature may fall below 0°C or exceed 50°C, provide a fan or air conditioner.
- Do not mount this unit in a panel where a high voltage device is installed.
- Place this unit as far away from power lines as possible.

5.2.2 Installing the BL-U1

There are 2 methods for installing the BL-U1.

■ Screw mounting

1. Pull out the 4 screw slot tabs from the rear panel of the BL-U1.

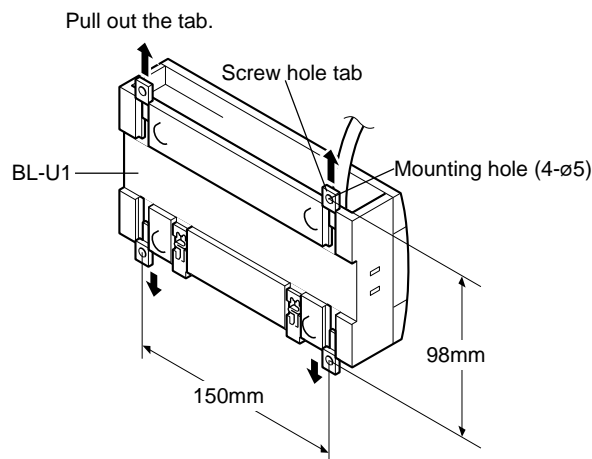

2. Secure the BL-U1 with screws.

* The mounting screws are not included.

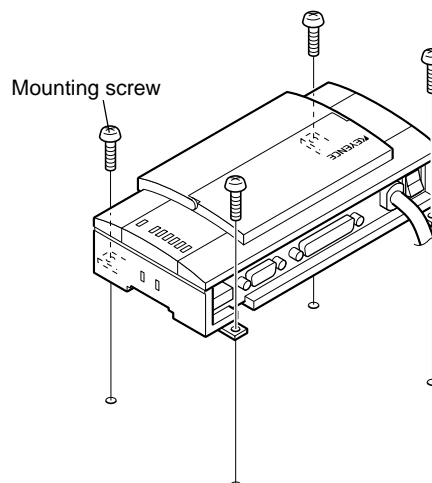

■ **DIN-rail mounting**

1. Check that the DIN-rail mounting claw is in the condition shown in the figure.

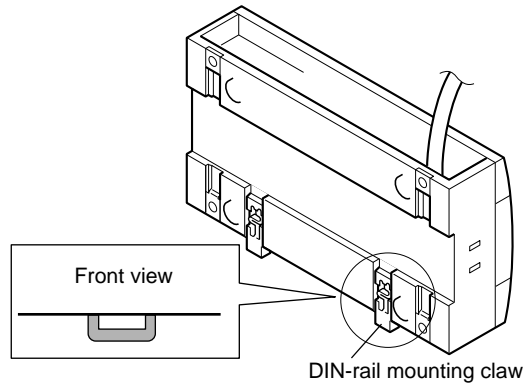

2. Attach the BL-U1 to the DIN rail as shown in the figure.

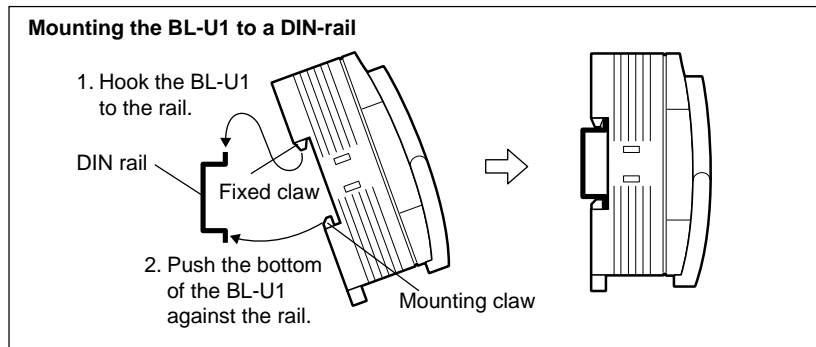
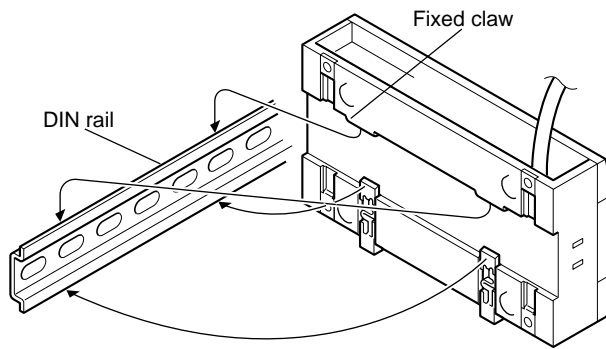

■ **Removal from a DIN rail**

1. Pull the mounting claw down until it is in position B. Disengage the BL-U1 from the DIN rail.
2. After removal, push the mounting claw back to position A.

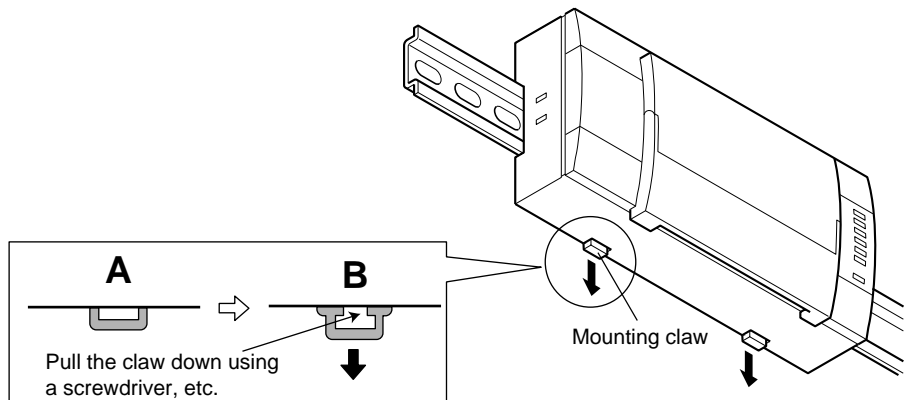

5.2.3 Installing the BL-U2 and N-42

Install the BL-U2 and N-42 using screws through the mounting holes.

* The mounting screws are not included.

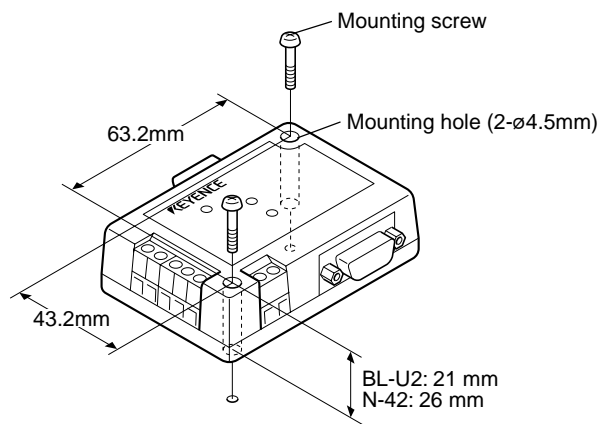

Chapter 6

Functions for Reading Operation

This chapter describes the reading operation and other functions, such as test mode, of the BL-600 Series.

6.1	Read Operation	86
6.1.1	Scanning method	86
6.2	Read Modes	88
6.2.1	Single label read mode	88
6.2.2	Multi-label read mode 1 (Multi 1)	89
6.2.3	Multi-label read mode 2 (Multi 2)	90
6.2.4	Multi-label read mode 3 (Multi 3)	91
6.3	Label Orientation Mode	93
6.4	Test Mode	94
6.4.1	Reading rate check mode	94
6.4.2	Tact check mode	97
6.4.3	Online test mode	99
6.5	Preset Function (Compare with:)	101
6.5.1	Preset function	101
6.5.2	Using “?” and “!” in the preset data	101
6.6	Additional Information Function	102
6.6.1	Decode match count add function	102
6.6.2	Scan count add function (valid only if using the decoding count add function)	102
6.6.3	Code type add function	103
6.6.4	Label orientation add function	103
6.6.5	Symbology ID add function	104
6.6.6	PMI add function	104
6.6.7	Order of the additional information	106
6.7	Max. Code Length (Designated Digit) Output Function	107

6.1 Read Operation

This section describes the scanning methods of the BL-600 Series.

6.1.1 Scanning method

There are two methods to trigger the BL-600 Series to read bar codes: the “Level signal” method and the “One-shot signal” method. Select an appropriate method according to the application. Typically, the “Level signal” method is used. The following examples for these two methods use the “6.2.1 Single label read mode”. ↪ See page 88.

Level signal trigger

When the trigger input turns on, the BL-600 Series starts laser emission to read the bar codes. The laser turns off after the number of the bar code reading reaches the specified decoding match count. ↪ See page 43. The BL-600 Series then sends the read data.

Reference 1: The BL-600 Series can read up to 4 types of bar codes without changing settings. ↪ See page 49.

Reference 2: Pressing the TEST switch lightly (for less than 2 seconds) serves as a trigger input (The laser turns on once.). ↪ See page 8.

■ Timing diagram

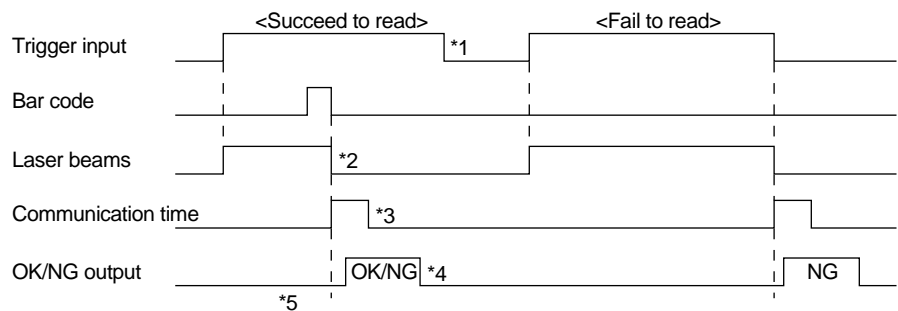

*1 Set trigger input so that it stays on long enough for the laser beam to cover the entire bar code.

*2 The BL-600 Series emits a laser after the trigger input exceeds the preset input time. ↪ See the following note.

Note: The BL-600 Series has a built-in AGC (auto gain control) circuit. It requires a maximum of 3 scans (6 ms) to adjust the gain. Therefore, the BL-600 Series requires a maximum of 6 ms after the laser beam turns on before it begins to read the data.

*3 The communication time can be obtained from the following expression:

$$\frac{\text{Data bits} + (1: \text{If parity is used}) + \text{Start/stop bit}}{\text{Baud rate}} \times (\text{Code length of data to be sent} + \text{Header/number of characters in delimiter})$$

*4 The length of time that the OK/NG output is on can be changed to any value between the range of 10 ms to 2.55 s. ↪ See page 53.

*5 The OK/NG output turns on 5 ms after the bar code is read. If the bar code cannot be read, the NG output is delayed by 5 ms plus the specified input time.

Note: 5 seconds after the power switch turns on or an UNLOCK command (⇨ See page 116.) is sent, the unit will not start reading a bar code by turning on the trigger input.

One-shot signal trigger

The BL-600 Series detects when the trigger input turns on and starts reading bar codes for the preset “One shot input time”. ⇨ See page 44. The laser turns off after the number of the bar code reading reaches the specified decoding match count. ⇨ See page 43. The BL-600 Series then sends the read data. The rest of the operation is the same as that for the “Level signal” method. Use the one-shot signal trigger when the one shot input time is extremely short or to fix the scanning time.

Reference 1: The BL-600 can read up to 4 types of bar codes without changing the bar code type setting. ⇨ See page 49.

Reference 2: Pressing the TEST switch lightly (for less than 2 seconds) serves as a trigger input (The laser turns on once.). ⇨ See page 8.

■ Timing diagram

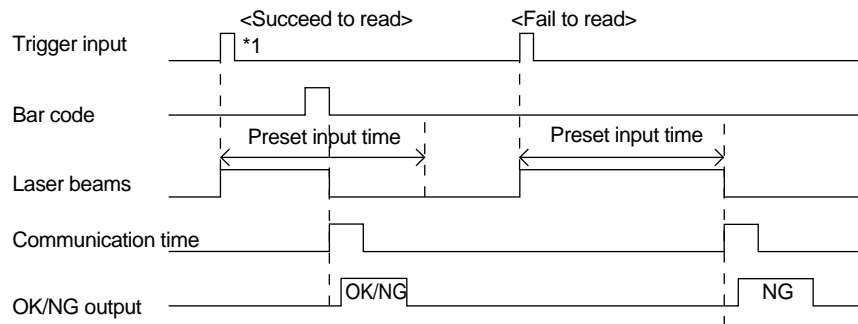

*1 After the trigger input exceeds the preset input times, the laser begins to emit.

Trigger input minimum ON time:

5 ms (when the trigger input value is 2 ms)

15 ms (when the trigger input value is 10 ms)

Note: The BL-600 has a built-in AGC (auto gain control) circuit. It requires a maximum of 3 scans (6 ms) to adjust gain. The BL-600 generates a maximum of 6 ms delay until starting to read the data after the laser beam turns ON.

6.2 Read Modes

The BL-600 provides 4 types of read modes.

6.2.1 Single label read mode

The single label read mode allows the BL-600 Series to read only one bar code during one trigger input signal.

■ Data output timing

The BL-600 Series offers the following two data output modes to send data and output OK/NG signals. Select an appropriate mode according to the application. Typically, “After Read” is selected.

- After Read ⇨ *See page 42.*
The BL-600 Series sends read data and outputs an OK/NG signal after a successful read.
This is the operation described in “6.1.1 Scanning methods” on page 86 and 87.
- At trigger input ⇨ *See page 42.*
The BL-600 Series sends read data and outputs an OK/NG signal at the following timings.
 - For a “Level signal” trigger ⇨ *See page 86.:*
When the trigger input turns off
 - For a “One-shot” trigger ⇨ *See page 87.:*
After the preset input time has passed

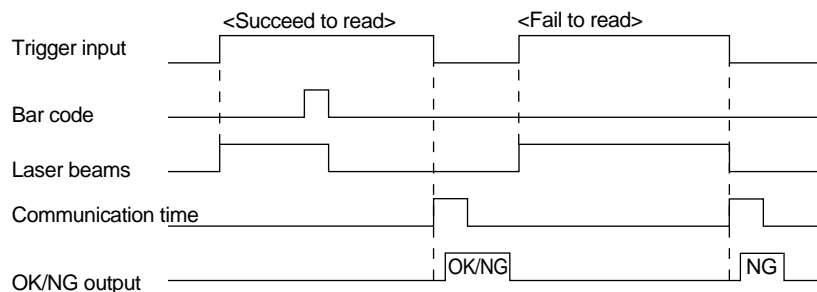

* The timing diagram above shows the case for a “Level signal” trigger.

6.2.2 Multi-label read mode 1 (Multi 1)

Multi-label read mode 1 allows the BL-600 Series to continuously read all of the several bar codes printed on one label during one trigger input signal. The BL-600 Series outputs the read data every time one bar code is read.

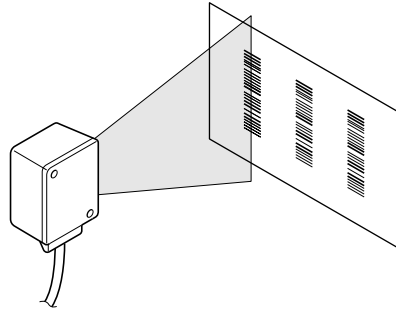

■ Timing diagram

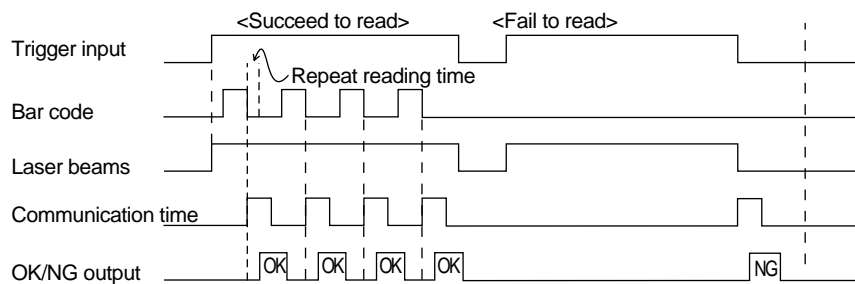

- * The BL-600 Series continuously reads bar codes in the following periods.
 - For a “Level signal” trigger ⇨ See page 86.:
During the trigger input signal
 - For a “One-shot” trigger ⇨ See page 87.:
During the preset input time
- * It is necessary to set the “Repeat-reading time” (⇨ See page 42.) to prevent the BL-600 Series from reading the same bar code twice. Set the “Repeat-reading time” longer than the time it takes for the read bar code to go out of the field of the laser beam (100 ms to 25.5 s).

Note: The same type of bar code cannot be read during the specified repeat-reading time. Different types of bar codes can be read continuously during the period.

- * The OK output turns on every time the BL-600 Series reads a bar code. (Comparison to the preset data is not performed.)
The NG output turns on after the trigger input turns off if the BL-600 Series fails to read any of the bar codes.

6.2.3 Multi-label read mode 2 (Multi 2)

Multi-label read mode 1 allows the BL-600 Series to continuously read all of the several bar codes printed on one label during one trigger input signal.

- * The number of readable bar codes varies depending on the capacity of the transmission buffer of the BL-600 Series. ⇨ See page 112.

In multi-label read mode 2, all the read data is sent at one time after the trigger input turns off.

■ Timing diagram

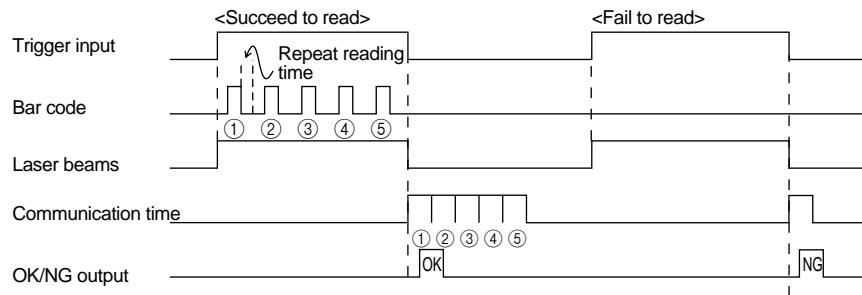

- * The BL-600 Series continuously reads bar codes in the following periods.
 - For a “Level signal” trigger ⇨ See page 86.:
During the trigger input signal
 - For a “One-shot” trigger ⇨ See page 87.:
During the preset input time has passed
- * It is necessary to set the “Repeat-reading time” (⇨ See page 42.) to prevent the BL-600 Series from reading the same bar code twice. Set the “Repeat-reading time” longer than the time it takes for the read bar code to go out of the field of the laser beam (100 ms to 25.5 s).

Note: The same type of bar code cannot be read during the specified repeat-reading time. Different types of bar codes can be read continuously during the period.

- * The OK signal turns on if the BL-600 Series reads at least one bar code. (Comparison to the preset data is not performed.)
The NG signal turns on if the BL-600 Series fails to read any of the bar codes.

■ Data format

The read data is sent to the personal computer in the following format.

Header	1st data	,	2nd data	,	3rd data	,	4th data	,	Delimiter
--------	----------	---	----------	---	----------	---	----------	---	-------	-----------

- * Each data packet is separated by a comma (, : 2CH) (intermediate delimiter).
 - * The unit sends as many data packets the number of bar codes read.
 - * The number of bar codes varies depending on the capacity of the transmission buffer of the BL-600 Series. ⇨ See page 112.
- ⇨ See page 113 for “header string” and “delimiter”.

6.2.4 Multi-label read mode 3 (Multi 3)

- Multi-label read mode 3 allows the BL-600 Series to continuously read one of each of the 4 bar code types, “Code 1” to “Code 4”, as specified in the [[Code setup]] screen of the setup software (⇒ See page 49.) during one trigger input signal.
- * If three types are specified in the [[Code setup]] screen, the BL-600 Series reads three bar codes. If two types are specified, it reads two bar codes.
- Even if several bar codes (4 max.) exist in the field of the laser beam, the BL-600 Series can simultaneously read all the bar codes, provided the data of all the bar codes is different.

The BL-600 Series sends all the read data at one time in the order of “Code 1” to “Code 4” after the trigger input turns off.

■ Timing diagram

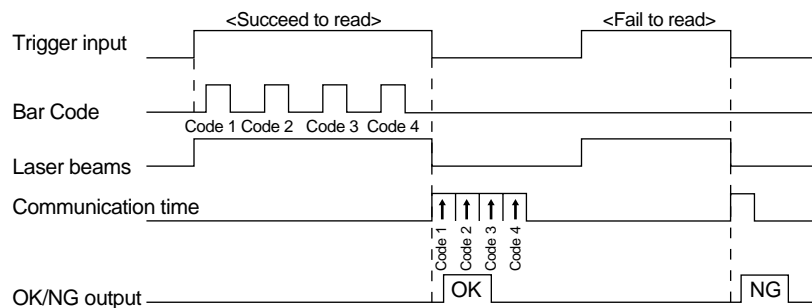

- * The BL-600 Series continuously reads bar codes in the following periods.
 - For a “Level signal” trigger ⇒ See page 86.:
During the trigger input signal
 - For a “One-shot” trigger ⇒ See page 87.:
During the preset input time
- * The OK signal turns on if the BL-600 Series reads all the bar codes specified for “Code 1” to “Code 4”. (Comparison to the preset data is not performed.)
The NG output turns on if the BL-600 Series fails to read at least one bar code.

■ Data format

The read data is sent to the personal computer in the following format.

Header	Data read from Code 1	,	Data read from Code 2	,	Data read from Code 3	,	Data read from Code 4	Delimiter
--------	-----------------------	---	-----------------------	---	-----------------------	---	-----------------------	-----------

- * Each data packet is separated by a comma (, : 2CH) (intermediate delimiter).
 - * If the reading fails for any one of the Codes 1 to 4, or the corresponding bar code does not exist, an “ERROR” (⇒ See page 112 for the reading error codes.) is sent instead of the read data.
- ⇒ See page 113 for “header string” and “delimiter”.

Example

Suppose that the following codes are specified:

“Code” setting	Type of bar code	No. of digits
Code 1	CODE39	10 digits
Code 2	EAN/UPC	13 digits
Code 3	–	–
Code 4	CODE39	8 digits

- When the unit successfully reads all 3 types of codes:

Header	ABCDE12345	,	4901234567894	,	KEYENCE1	Delimiter
--------	------------	---	---------------	---	----------	-----------

- When the unit fails to read Code 1 (CODE39, 10 digits)

Header	ERROR	,	4901234567894	,	KEYENCE1	Delimiter
--------	-------	---	---------------	---	----------	-----------

- When the unit fails to read Code 1 (CODE39, 10 digits) and Code 4 (CODE39, 8 digits)

Header	ERROR	,	4901234567894	,	ERROR	Delimiter
--------	-------	---	---------------	---	-------	-----------

- * When the same type of data having the same digits is specified to all Codes 1 to 4, the unit sends the data in the reading order.

Example

Suppose that the following codes are specified:

“Code” setting	Type of bar code	No. of digits
Code 1	CODE39	7 digits
Code 2	CODE39	7 digits
Code 3	CODE39	7 digits
Code 4	CODE39	7 digits

Header	ABCD123	,	XYZ3333	,	1234567	,	KEYENCE	,	Delimiter
--------	---------	---	---------	---	---------	---	---------	---	-----------

Note: The unit cannot read the bar code having the same content twice while trigger input turns on once.

6.3 Label Orientation Mode

You can specify the orientation of the bar code labels to be read.

The label orientation mode allows the BL-600 Series to only read the bar codes in the specified orientation if the bar code labels are moving in both the forward and reverse directions.

Normally, the unit can read bar codes regardless of the orientation. \Rightarrow See page 53.

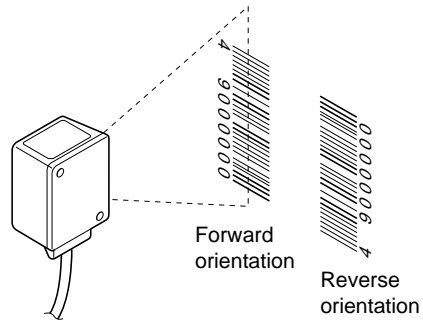

■ Timing diagram

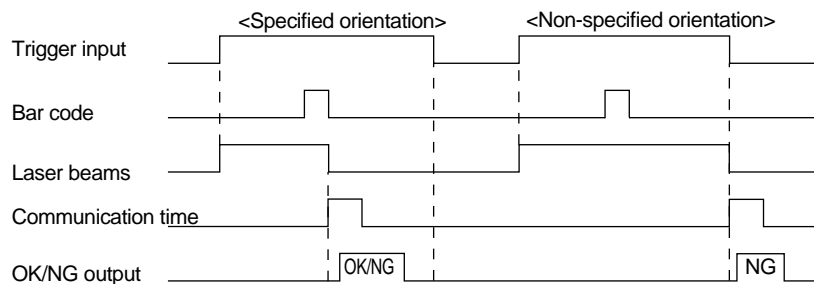

* The timing diagram above shows the case for the “single label read mode”.

- A reading error is issued if the BL-600 Series reads a bar code label moving in an orientation that is not specified.
- This mode can be used with the desired multi-label read mode. However, the BL-600 Series does not read bar codes moving in an orientation that is not specified.
- You can specify the orientation individually for Codes 1 to 4, such as specifying “forward orientation” for Code 1, and “reverse orientation” for Code 2.

6.4 Test Mode

Test mode can be used for the bar code reading test. The BL-600 Series offers three types of test mode.

Note: The BL-600 Series continues laser emission during test mode. This can shorten the service life of the laser. Only select test mode when you need to perform a reading test.

6.4.1 Reading rate check mode

The reading rate check mode is used to measure how many times the BL-600 Series can decode the scanned data while scanning a bar code 100 times. This mode is useful for the following cases:

- Adjusting the mounting distance and angle
Adjust the mounting distance and angle so that the highest reading rate is obtained.
- Verifying the reading reliability of the bar code to be used
A high reading rate shows that the printing quality of the bar code is high.

Note: The reading rate check should only be performed for a stationary bar code.

■ Starting method

There are four methods to start the reading rate check mode. Select one of the following for your convenience.

- Press the TEST switch of the BL-600 Series.
- Use the [[Monitor]] screen of the setup software. ⇨ See page 62.
- Use the bar code display interface BL-V35E. ⇨ See the BL-V35E User's Manual.

■ Operation

The following instruction uses the TEST switch to start/quit the reading rate check. All other operations are the same for the other starting methods.

1. Set the mounting distance and angle of the BL-600 Series. ⇨ See page 75.

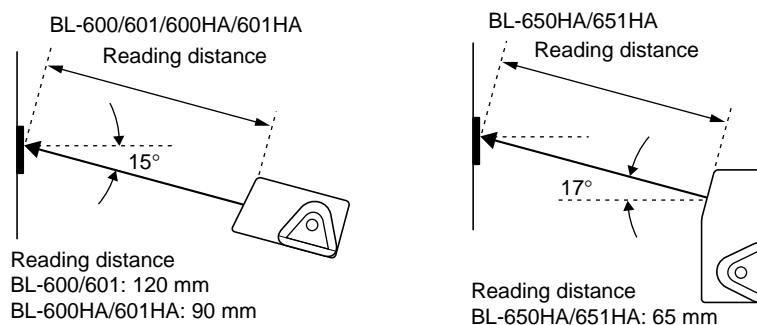

Note : Do not mount the BL-600 Series so that the laser beam is applied to bar codes at a right angle ($\pm 10^\circ$). Otherwise, the specular reflections may cause unstable reading or reading errors. ⇨ See page 151.

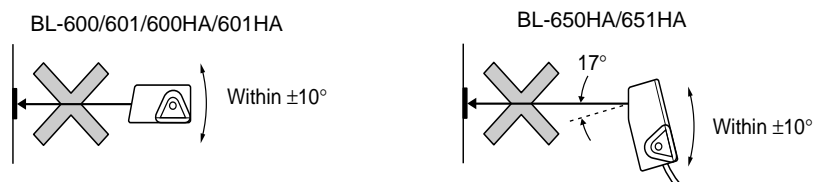

2. Start the test mode.
 - 1) Press the TEST switch for 3 seconds.
 - 2) When one STABILITY LED illuminates, release the TEST switch.
The BL-600 Series continues laser emission.

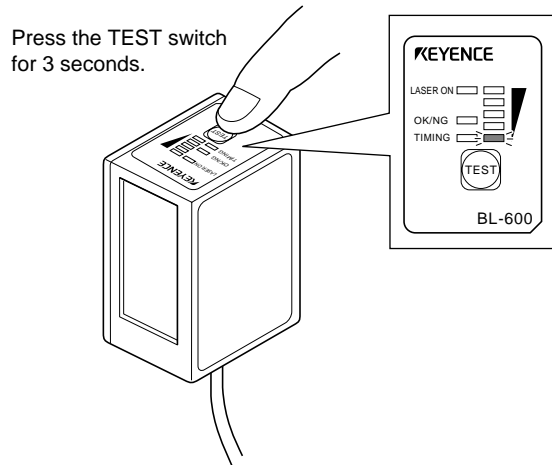
**WARNING**

Do not look directly at the laser beam. This may result in serious eye injury. The laser beam is not harmful to the skin; however, do not intentionally direct the laser beam at the human body.

3. Read the bar code.

The BL-600 Series displays the STABILITY LEDs as shown in the following table depending on the "Reading rate", which shows the number of times it can decode the scanned data while scanning a bar code 100 times. While checking the display, adjust the mounting distance and angle so that the reading rate reaches its highest level.

* ON/NG LED turns ON but OK/NG output does not turn ON.

Reading rate	STABILITY LED	OK/NG LED
81 to 100 %	5 LEDs ON	Green
61 to 80 %	4 LEDs ON	Green
41 to 60 %	3 LEDs ON	Green
21 to 40 %	2 LEDs ON	Green
1 to 20 %	1 LED ON	Green
0 %	—	Red

Note1: The higher the reading rate indicated, the more accurately and reliably the bar code is read. However, this does not mean that the reading is only possible with a reading rate of 100%. For example, if the reading rate is displayed as 20%, 20 reads were acceptable during the 100 scans. The read operation is not affected if the scanning time for the bar code is set long enough.

Note2: If a raster-scanning model (BL-601/601HA/651HA) is used for a bar code with a short height, some laser beams will not be applied to the bar code, resulting in a low reading rate. For example, if only 4 out of the 8 laser beams of the BL-600 Series can scan the bar code, the highest reading rate obtained will be 50%. However, this problem can also be solved if the scanning time for the bar code is set long enough.

4. The BL-600 Series sends data.

In test mode, the BL-600 Series sends the data in the following format every 100 scans.

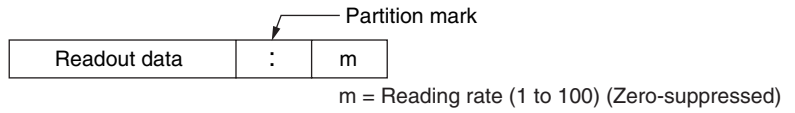

- * You can set the BL-600 Series so that it will not send data while in the test mode. ⇨ See page 54.
- * To check the reading rate on a PC screen, connect the BL-600 Series to a PC and use the [[Monitor]] screen of the setup software. ⇨ See page 62.

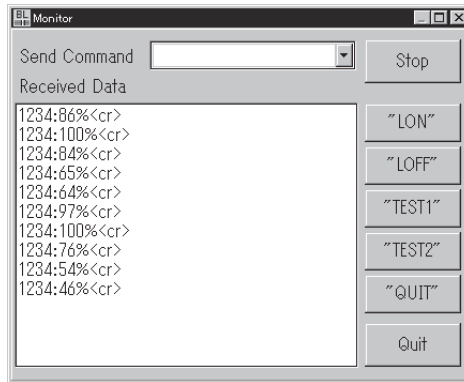

5. Quit the test mode.

Press the TEST switch again to quit the test mode. The STABILITY LED turns off.

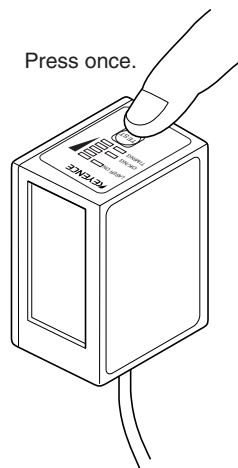

Note 1: If the additional information function (⇨ See pages 102 to 106.) is used while in the test mode, the BL-600 Series adds the specified data in the same manner as in normal operation. However, only if the “Reading rate check mode” is selected, will the “Decoding count” and “Scan count” data not be added.

Note 2: If a PLC link is used, the read data, reading rate, and decoding count are not written while the test mode is active.

6.4.2 Tact check mode

The tact check mode is used to count how many scans the BL-600 Series can accurately read (decode) while reading a moving bar code.

This mode is useful for the following case:

- Testing the line speed that can be expected before actually implementing the BL-600 Series on the line

A large decoding number shows that the BL-600 Series can reliably read the bar code (capable for the line speed).

Note: The tact check should be performed on a moving bar code.

■ Starting method

There are four methods to start the reading rate check mode. Select one of the following for your convenience.

- Press the TEST switch of the BL-600 Series.
- Use the [[Monitor]] screen of the setup software. ⇨ See page 62.
- Use the bar code display interface BL-V35E. ⇨ See the BL-V35E User's Manual.

■ Operation

The following instruction uses the TEST switch to start/quit the reading rate check. All other operations are the same for the other starting methods.

1. Install the BL-600 Series.

Install the BL-600 Series according to “Chapter 5, Installation” on page 72.

2. Start the test mode.

- 1) Press the TEST switch for 5 seconds.
- 2) When two STABILITY LED illuminates, release the TEST switch.
The BL-600 Series continues laser emission.

Press the TEST switch
for 5 seconds.

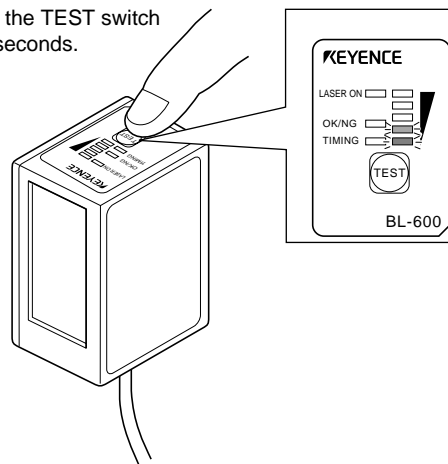

Do not look directly at the laser beam. This may result in serious eye injury. The laser beam is not harmful to the skin; however, do not intentionally direct the laser beam at the human body.

3. Read the bar codes moving on the line.

Depending on the decoding count, the BL-600 Series displays the STABILITY LEDs as shown in the following table 0.2 seconds after the bar code has passed the field of the laser beam. By checking the display, you can notice the reliability that the BL-600 Series ensures during the readout (how capable it is for the line speed).

Decoding count	STABILITY LED	OK/NG LED
100 or more	5 LEDs ON	Green (The readout count equals or exceeds the specified decoding match count.) ⇨ See page 43.
50 to 99	4 LEDs ON	
10 to 49	3 LEDs ON	Red (The readout count is below the specified decoding match count.) ⇨ See page 43.
5 to 9	2 LEDs ON	
1 to 4	1 LED ON	

- * ON/NG LED turns ON but OK/NG output does not turn ON.
- * The BL-600 Series continues to read data while bar codes are in the field of the laser beam. Therefore, the STABILITY LEDs do not illuminate.
- * If reading bar codes with the same data continuously within 0.2 seconds, the BL-600 Series cannot differentiate between the data and continues to scan and add to the decoding count without displaying the STABILITY LEDs. If the BL-600 Series reads different bar codes within 0.2 seconds of each other, it displays the STABILITY LEDs to show the decoding count.

4. The BL-600 Series sends data.

The BL-600 Series sends the data to the PC in the following format every time the STABILITY LEDs illuminate.

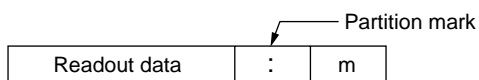

m = Decoding count (1 to 9999) (Zero-suppressed)

- * A value greater than 9999 cannot be added.
- * You can set the BL-600 Series so that it will not send data while in the test mode. ⇨ See page 54.

Note: It should be judged that the BL-600 Series is capable for the line speed if the decoding count is always more than 5 to 10. If the decoding count is only 1 or 2, you need to perform a reading rate check (⇨ See pages 94 to 96.) and change the position of the bar code reader to obtain a higher reading rate.

- * To check the reading rate on a PC screen, connect the BL-600 Series to a PC and use the [[Monitor]] screen of the setup software. ⇨ See page 62.

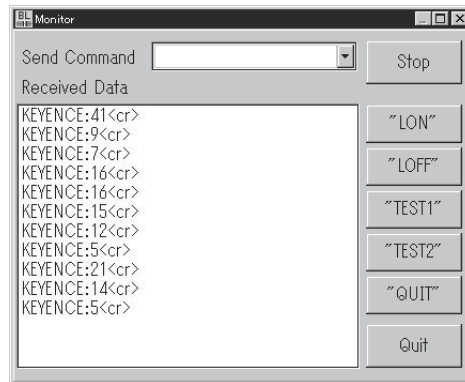

5. Quit the test mode.

Press the TEST switch again to quit the test mode. The STABILITY LED turns off.

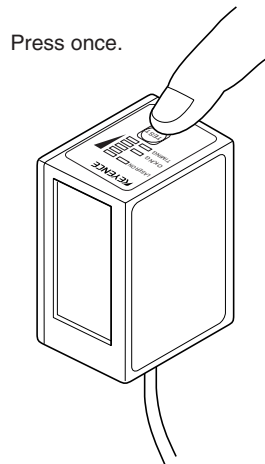

6.4.3 Online test mode

The online test mode allows the BL-600 Series to display the reading reliability in real time during normal reading operation.

■ Operation

1. Set the online test mode.
 - 1) Send the "#TEST1" command to the BL-600 Series using the [[Monitor]] screen of the setup software. ⇨ See page 62.
 - 2) The setting is completed when a response to the sent command "OK" is returned from the BL-600 Series.
2. Read bar codes with the BL-600 Series.

After the trigger input turns off, the BL-600 Series sends the read data and displays the reading reliability with the STABILITY LEDs.
3. Quit the online test mode.
 - 1) Send the "#QUIT" command to the BL-600 Series using the [[Monitor]] screen of the setup software. ⇨ See page 62.
 - 2) The mode is ended when a response to the sent command "OK" is returned from the BL-600 Series.

Note: The command setting is only effective if the BL-600 Series is turned on. The setting will be reset when the power is turned off.

Reference: To save the online test mode setting in the BL-600 Series, set the following using the setup software.

- [[Main]] → “Additional information” → Select “Decoding count”.
 ⇨ See page 43.
 → Select “Scan count”.
 ⇨ See page 43.
- [[Utilities]] → “Stability LED” → Select “Use stability LED”.
 ⇨ See page 53.

■ **STABILITY LED display**

The STABILITY LEDs illuminate as shown in the table, indicating how many times the BL-600 Series can correctly read (decode) the data of the moving bar codes.

Decoding count	STABILITY LED
100 or more	5 LEDs ON
50 to 99	4 LEDs ON
10 to 49	3 LEDs ON
5 to 9	2 LEDs ON
1 to 4	1 LED ON
0	—

■ **Data format**

The BL-600 Series appends the number of scans (scan count) and the number of correctly read bar codes (decoding count) while one trigger input turns on.

- * The scan count includes the cases where a bar code does not exist in the field of the laser beam.

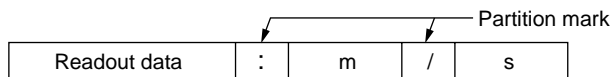

m = Decoding count (1 to 9999) (Zero-suppressed)
 s = Scan count (1 to 9999) (Zero-suppressed)

6.5 Preset Function (Compare with:)

This section describes the preset function to prevent different bar codes from being read.

6.5.1 Preset function

The preset function is the function that compares the preset data (one bar code data entered beforehand) to the bar code data actually read and outputs OK/NG signals to indicate whether or not there is a match.

The preset function allows the BL-600 Series to detect different bar codes without using a PC.

■ OK/NG signal output timing

⇒ See pages 86 to 88.

■ Entering the preset data

Use the setup software (⇒ See page 53.) or a serial command (⇒ See page 128.) to enter the preset data.

Note: The bar code actually read can be compared to the preset data only in the single label read mode.

⇒ See page 164 if you want to use CODE93.

⇒ See page 165 if you want to use CODE128.

6.5.2 Using “?” and “!” in the preset data

Using “?” and “!” in the preset data allows a wider range of bar codes to match the preset data.

?: One “?” character represents one character. Use “?” to regard any one-digit character as being matched.

If the preset data is entered as “4912??56”, the two digits positioned in “??” can contain any characters (numeric values) for a match.

!: One “!” character represents an unlimited number of characters. Use “!” to regard any number of characters as being matched.

If the preset data is entered as “4912!”, any bar codes that begin with “4912” will be regarded as a match. If the preset data is “!4912”, any bar codes that end with “4912” will be regarded as a match.

You can only use “!” once in one preset data.

Setting examples

1. “ABC?” ABCD (OK), ABC3 (OK), ABC (NG), ABCDE (NG)
2. “ABC!” ABCD (OK), ABC3 (OK), ABC (OK), ABCDE (OK), AB (NB)
3. “?????” Any 5-digit bar code will be OK.
4. “!CDE” ABCDE (OK), 3CDE (OK), CDE (OK), ABBDE (NG), ADE (NG)
5. “A!E” ABCDE (OK), A3CE (OK), ABCD (NG), AE (OK)

Reference: If you do not register preset data, “!” is automatically registered. Therefore, when the unit successfully reads a bar code, “OK” is output; when the unit fails to read, “NG” is output.

6.6 Additional Information Function

This section describes the additional information function that allows the BL-600 Series to send the read data together with various additional data.

6.6.1 Decode match count add function

Adds the number of successful scans during one bar code reading (decode count) to the end of the readout data (up to 9999 count). However, this decode count is never less than the preset decoding match count. This function can be used to check reading stability and code label quality.

■ Data format

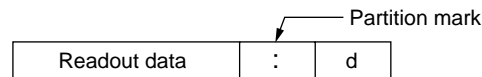

d = [Decoding match count] to 9999: Decode count

* The partition mark (:) can be changed as desired (1 character max.).

■ Data output timing

If the decoding count add function is used, the data is output at a different time than with normal operation.

- If single label read mode is used:
The data is always output after the trigger input turns off.
- If multi-label read mode 1 is used:
The data is output when the repeat-reading time has passed after a bar code passes across the field of the laser beam.
- If multi-label read mode 2 or 3 is used:
The operation is the same as when the decoding count add function is not used.

6.6.2 Scan count add function (valid only if using the decoding count add function)

If the decoding count add function is used, you can add the number of scans while the trigger input is on, including when the reading has failed and when a bar code does not exist, to the end of the decoding count (up to 9999).

■ Data format

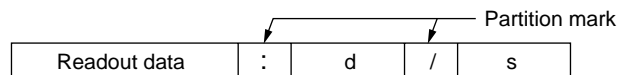

s = Scan count (1 to 9999) (Zero-suppressed)

* The partition mark (:) can be changed as desired (1 character max.). However, the partition mark for the scan count (/) cannot be changed.

6.6.3 Code type add function

Adds the bar code type before the readout data .

■ Data format

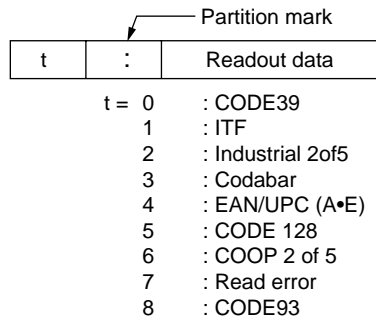

* The partition mark (:) can be changed as desired (1 character max.).

6.6.4 Label orientation add function

Adds the orientation of bar code travel before the readout data.

◇ See pages 52 and 93

■ Data format

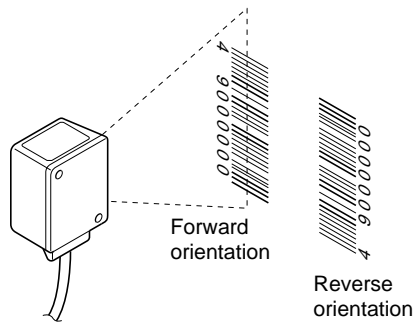
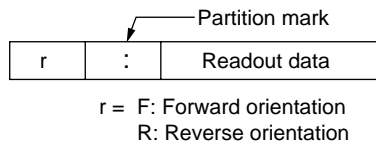

- * If an read error occurs, this information is not added.
- * The partition mark (:) can be changed as desired (1 character max.).

6.6.5 Symbology ID add function

Adds the bar code symbology identifier specified by AIM.

■ Data format

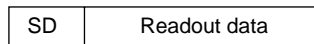

* No partition mark is used.

Bar code type	Data specification	Symbology identifier (SD)
CODE39	No check digit]A0
	Inspect check digit (sent).]A1
	Inspect check digit (not sent).]A3
ITF	No check digit]I0
	Inspect check digit (sent).]I1
	Inspect check digit (not sent).]I3
Industrial 2of5	—]S0
Codabar	—]F0
UPC/EAN	13-digit EAN]E0
	8-digit EAN]E4
	UPC-A 13-digit format]E0
	UPC-A 12-digit format	None
	UPC-E	
CODE128	No FNC1]C0
	FNC1 is on the 1st digit of data (EAN-128).]C1
	FNC1 is on the 2nd digit of data.]C2
CODE93	—]G0
COOP 2of5	—]X0

6.6.6 PMI add function

Adds the data indicating the reading reliability of the bar codes (PMI: Preventive Maintenance Information).

You can recognize a low reading reliability due to a low printing quality of bar code labels or a dirty transmitter/receiver of the BL-600 Series, taking appropriate actions before serious problems can occur.

* The PMI add function is only available if the single label read mode is used.

■ Data format

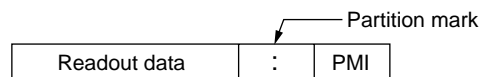

- PM1 = 0 : Normal
- 1 : Caution
- 2 : Warning
- 9 : Reading error

* The partition mark (:) can be changed as desired (1 character max.).

■ Assessment criteria for PMI

The BL-600 Series assesses the PMI (Preventive Maintenance Information) in four levels by calculating the multiplier for the scan count between laser emission start and reading completion with reference to the specified decoding match count.

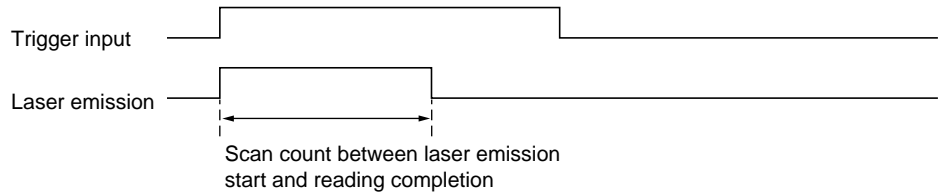

The BL-600 Series calculates the PMI using the following calculations. The assessment uses two reference values (L1: Preset value 1, L2: Preset value 2).

* Be sure to set L2 larger than L1.

PMI	Calculation	Assessment
0	Scan count/Decoding match count \leq L1	Normal
1	L1 < Scan count/Decoding match count \leq L2	Caution
2	L2 < Scan count/Decoding match count	Warning
9	Reading error	Reading error

Note: The scan count includes scans that are not applied to a bar code. If many scan counts are not applied to a bar code, such as if using a raster-scan type reader, increase the preset values (L1 and L2).

Example:

When the decoding match count is 2, preset value 1 (L1) is 5, and preset value 2 (L2) is 10:

- Scan count for L1: 2 (Decoding match count) \times 5 (L1) = 10
- Scan count for L2: 2 (Decoding match count) \times 10 (L2) = 20

As a result, PMI is assessed as follows:

- 10 scans or less \rightarrow PMI = 0
- From 11 scans to 20 scans \rightarrow PMI = 1
- 21 scans or more \rightarrow PMI = 2

■ Setting the PMI preset values

First, perform a reading rate check. Then, check the result and the following table to determine the preset values. A reading rate of less than 20% is not included.

Reading rate	Preset value 1	Preset value 2
20% to 39%	6	12
40% to 59%	5	10
60% to 79%	4	8
80% to 100%	3	6

The above values should only be used as a guide. Select the optimal value according to the operating conditions for a more severe or a more moderate criteria.

Reference: When the preset value 1 (L1) is set to "0", there is no assessment criteria for preset value 1, so PMI 1 will not be displayed. If the preset value 2 (L2) is set to "0", there is no assessment criteria for preset value 2, so PMI 2 will not be displayed.

■ **Conditions for effective PMI**

To use PMI effectively, use the function under the following conditions:

- Set the BL-600 Series so that it emits the laser after the bar codes have completely entered the field of the laser beam.
If the BL-600 Series emits the laser before the bar codes enter the field of the laser beam, it will start counting scans with no bar codes, resulting in an inaccurate PMI.
- Use the PMI add function for stationary or slowly moving bar codes. If the bar codes move at a fast speed, the scan count for each bar code decreases, resulting in an inaccurate PMI. Use the function if the decoding count in the tact check mode (⇒ See page 94.) is at least 20.
- The PMI add function is only effective in “Single label read mode”.

■ **Useful examples of PMI applications**

- **Controlling the printing quality of bar codes**
Monitor the PMI constantly. If the PMI value is degraded, the printing quality of the bar code may have a problem. Inspect the bar code.
- **Preventing problems before they happen**
If using several BL-600 Series units, monitor the PMI of all the units constantly.
 - If the PMI value of a specific unit is degraded:
The unit may have a problem, such as a dirty transmitter/receiver.
 - If the PMI value for a specific bar code is degraded:
The bar code may have a problem, such as a low printing quality.

As shown above, PMI allows you to identify problems. You can take appropriate action before a reading error actually occurs.

6.6.7 Order of the additional information

If you select to include all the additional information functions, they appear in the following order:

Symbology identifier	Code type	:	Label orientation	.	Readout data	.	Decoding count	.	Scan count
----------------------	-----------	---	-------------------	---	--------------	---	----------------	---	------------

- * You can change the partition mark as desired (one character), except the delimiter of the scan count.
- * No partition mark is used for the symbology identifier.
- If the PMI add function is used, the decoding and scan counts cannot be added.

Symbology identifier	Code type	:	Label orientation	.	Readout data	.	PMI
----------------------	-----------	---	-------------------	---	--------------	---	-----

6.7 Max. Code Length (Designated Digit) Output Function

The max. code length output function allows the BL-600 Series to output only the designated digit(s) to the PC.

For example, you can extract “345” for the output from the bar code data “49123456”.

Individually set the function for Codes 1 to 4 by the following procedure.

⇒ See page 52.

1. Set “Direction”.

Set the direction, “Forward” or “Reverse”, from which you would like to start counting.

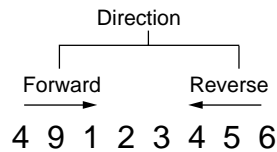

2. Set “Starting”.

Specify from which digit you would like to begin selection (designation start digit) in the direction specified in step 1.

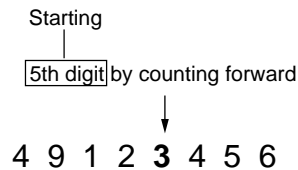

3. Set “Effective”.

Specify how many digits you would like to select for output (designation effective digits) starting from the designation start digit specified in step 2.

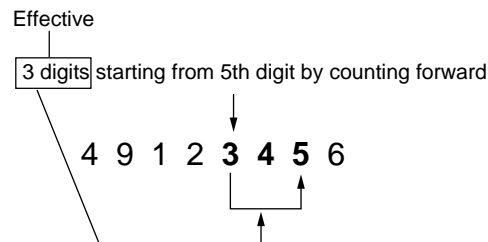

Note 1: The data is output in the forward direction regardless of the selected direction.

Note 2: When the bar code group includes those having different digits, take special care on the designated direction when setting the digits to be output.

Example

Designating and outputting “34” from bar codes “158423421” and “58423421”

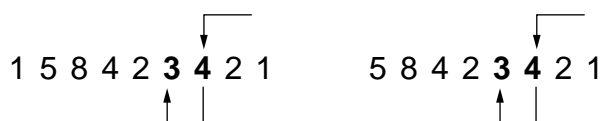

Designate 2 digits starting from 3rd digit by counting reversely.

Note 3: When comparing to the preset data, all the digits of the bar code are used.

Chapter 7

Serial Communication

This chapter describes the serial communication control.

7.1	Serial Communication	110
7.2	Details on Data Communication	111
7.3	Command Communication	114
7.3.1	Setup of direct control commands	114
7.3.2	Details on parameter setting commands	118

7.1 Serial Communication

Serial communication allows you to send the bar code read data from the BL-600 Series to a personal computer, or change the BL-600 Series settings from a personal computer without using the setup software.

Communication types

The BL-600 provides the following two communication types:

- Data communication
Sends read bar code data from the BL-600 to the PC.
- Command communication
Changes the BL-600's settings by sending a command from the PC to the BL-600.
- * All communication is performed using ASCII codes on page Appendix 26.

Communication setup

Configure the setup for BL-600 and the PC before attempting serial communication.

- Setup of BL-600
Set the following parameters for the BL-600 using the setup software.
 - Baud rate, Data bits, Parity, Stop bits ⇨ See page 45.
 - Communication protocol ⇨ See pages 45 and 46.
 - Header/Delimiter ⇨ See page 46.
 - Read error code ⇨ See page 43.
- PC setup
Based on the BL-600's settings, set the communication parameters on the PC using the "Ports" setting in the Windows Control Panel/System/Device Manager.
- The following communication parameters are the default settings for the BL-600:
 - Baud rate: 9600 bps
 - Data bits: 7 bits
 - Parity: Even
 - Stop bit: 1 bit

Tips

Set the PC according to the above settings before attempting communication.

- The BL-600 is set, temporarily, to the default settings for 5 seconds after the power switch is turned on.
When the current settings of BL-600 is not certain, send the command "SSET" (⇨ See page 116.) and a [CR] to the BL-600 from your PC with 5 seconds after power-up. This causes the BL-600 to remain at its default settings and you can communicate with the BL-600 at the default settings. For information on checking the BL-600's current settings, see "Sift to setting mode" on page 116.
For information on changing the above communication parameters see "Details on parameter setting commands" on page 118.
- When the BL-600 TEST switch is pressed for 8 seconds, the 1st, 3rd and 5th STABILITY LEDs from the top flash, indicating that the communication parameters are set as above. (Press the TEST switch again to reset the settings.)

Note: All commands should be entered in all uppercase characters. The BL cannot accept lowercase characters.

7.2 Details on Data Communication

This section describes the communication protocols and data format for data communication.

Communication protocols

The BL-600 supports the following four handshaking protocols (types of data communication).

■ No Handshaking

The BL-600 Series sends read data to the PC without any handshaking protocol.

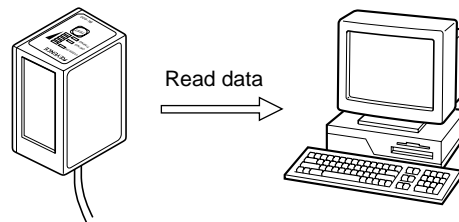

■ PASS/RTRY Handshaking

1. The BL-600 Series sends read data to the PC.
2. The BL-600 Series waits for a response from the PC (PASS: Transmission succeeded, RTRY: Request to re-send).
3. If "PASS" is sent from the PC to the BL-600 Series, the data transmission is complete. The BL-600 is ready for the next data transmission.
* The BL-600 Series does not respond to the "PASS" command.
4. If the BL-600 Series receives "RTRY" from the PC while waiting for "PASS", the BL-600 Series resends the same data and again waits for "PASS".
* Once the BL-600 Series receives a "PASS", it will send nothing, even if "RTRY" is received from the PC.
5. The BL-600 can continue to read bar codes while waiting for "PASS." The data is stored in the BL-600's transmission buffer. ⇨ See page 112.

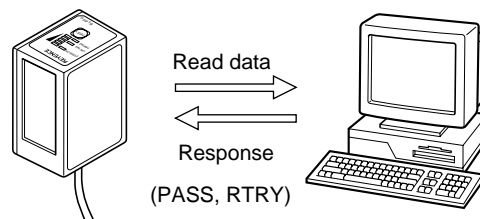

Note: If the amount of stored data exceeds the capacity of the transmission buffer, the BL-600 Series sends "[Header] OVER [Delimiter]" to the PC, and clears all the data stored in the transmission buffer. In this case, the BL-600 Series will stop operation. Operation is resumed when the BL-600 Series receives a "PASS" in response to "[Header] OVER [Delimiter]."

- PASS and RTRY can be received in either communication format
PASS <CR>(RTRY<CR>) or <STX> PASS <ETX>(<STX>RTRY<ETX>).
* An <ESC> can also be added to the beginning and an <LF> added to the end of the format.

Note 1: The BL-600 Series can receive all commands while waiting for a "PASS." In this case, the BL-600 Series will send back without waiting for a response to the command (e.g. OK).

Note 2: When the BL-600 Series receives the "SSET" command (⇒ See page 116.) while waiting for a "PASS", it clears all the data stored in the transmission buffer, and enters the setting mode.

■ ACK/NAK Handshaking

The ACK/NAK handshaking uses <ACK> (06H) and <NAK> (15H) instead of "PASS" and "RTRY", which are used in the PASS/RTRY handshaking. Operation is the same as that for the PASS/RTRY handshaking, except for the transmission characters.

■ RTS/CTS Handshaking

- When the PC's "RTS" (BL-600 series' CTS) signal turns off, the BL-600 Series suspends data transmission. When the PC's "RTS" signal turns on, the BL-600 Series sends the suspended data.
- The BL-600 Series can still read bar codes even if the PC's "RTS" signal is off. In this case, the data is stored in the BL-600 series' transmission buffer.
⇒ See page 112 for its capacity.

Note 1: If the amount of stored data exceeds the capacity of the transmission buffer, the BL-600 sends back [Header]OVER[Delimiter] to the PC, and clears all data stored in the transmission buffer. The BL-600 stops operation while clearing data. It recovers when the RTS of the computer turns ON.

Note 2: The RTS/CTS handshaking cannot be used for RS-422A communication.

Note 3: The RTS/CTS protocol can be used together with other handshaking protocols.

Note 4: When the PC's RTS signal is off, the BL-600 does not send back a response (e.g. OK [CR]) to the PC.

Capacity of transmission buffer

The BL-600's transmission buffer can store 400 bytes (400 characters).

The number of characters stored in the transmission buffer for each data packet is the number of characters in the data (including additional data such as the number of decoding match count) plus an additional five characters indicating the data's attributes.

When multi label reading mode 2 or 3 is used, these five attribute characters are added to each data packet.

Example 1

When the number of bar code digits is 10 (with no additional data)

$$400 \div (10 + 5) = 26$$

↑ ↑
 Capacity of Attributes of
 the transmis- the data
 sion buffer

The transmission buffer can store 26 pieces of data.

Example 2

When the number of bar code digits is 20 (with no additional data)

$$400 \div (20 + 5) = 16$$

↑ ↑
 Capacity of Attributes of
 the transmis- the data
 sion buffer

The transmission buffer can store 16 pieces of data.

Read data format

Set the data format of the Header and Delimiter, respectively.

Header	Read data	Delimiter
--------	-----------	-----------

With the setup software, the following formats can be selected. Other than the following formats, you can freely set up to 5 characters.

Header: <ESC> (1BH), <STX> (02H), None

Delimiter: <CR> (0DH), <CR> (0DH) <LF> (0AH), <ETX> (03H)

Read error code

If the BL-600 Series fails to read a bar code, it sends back a read error code. The initial setting of the read error code is as follows:

Header	ERROR	Delimiter
--------	-------	-----------

The read error code can be changed as desired (within 8 characters). The BL-600 can be set to send no error code.

⇒ See page 43.

7.3 Command Communication

The BL-600 includes commands to directly operate the BL-600 (direct control commands) and the commands used to change or confirm the BL600's settings (parameter setting commands).

7.3.1 Setup of direct control commands

Communication procedure

1. Send a direct control command from the PC to the BL-600.
2. After receiving a command, the BL-600 Series sends back an OK response and executes the required operation.
 - * The BL-600 Series does not send back a response for the read operation and test mode control commands.
 - * When an incorrect command is sent to the BL-600, the BL-600 sends back no response.

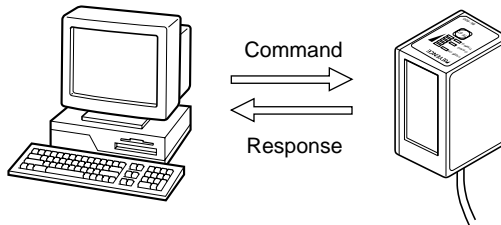

Communication format

When the command format is **[Command][CR]**, the response format is **[Response][CR]**. When the command format is **[STX][Command][ETX]**, the response format is **[STX][Response][ETX]**.

Command	Response
Command [CR]	Response [CR]
[STX] Command [ETX]	[STX] Response [ETX]

- * **<LF>** can be added after the command being sent. In this case, however, **<LF>** is not added to the response data.

Note 1: When **<ESC>** is inserted before the command being sent, characters in the BL-600's command receiving buffer are cleared.

Note 2: If the BL-600's command receiving buffer contains erroneous characters due to data transmission error during communication, add **<ESC>** to the command being sent.

Note 3: For command communication, set the time duration between transmission of each character (byte) to up to 30 seconds. If this duration exceeds 30 seconds, the BL-600 cancels the received characters.

Explanation of direct control commands

The following describe direct control commands in details.

Read operation control

This command specifies the data read timing.
--

- **Trigger on**

Command: LON

Response: None

- **Trigger off**

Command: LOFF

Response: None

- Even when the read operation is controlled with these commands, the BL-600 performs the same operation as with the trigger input. ↪ See pages 86 to 93. “Trigger input: on” corresponds to LON, and “trigger input: off” corresponds to LOFF.
- The BL-600 Series starts reading bar codes on receipt of LON and stops reading on receipt of LOFF.
If the bar codes are properly read and the read data is sent back, you do not need to send LOFF.
- The command characters can be freely changed (within 8 characters).

Test mode control

Starts or quits the test mode.

- **Reading rate check**

Command: TEST1

Response: None

- **Tact check**

Command: TEST2

Response: None

- **Resetting test**

Command: QUIT

Response: None

- After using the test mode, be sure to reset it.

OK/NG output control

Directly turns on/off the OK/NG output. This enables you to easily check wiring.

- **Turning the OK output on**

Command: OKON

Response: OK

- **Turning the NG output on**

Command: NGON

Response: OK

- **Turning the OK/NG outputs off**

Command: ALLOFF

Response: OK

Online test mode

Sets to online test mode. ⇨ See pages 99 and 100.

● **Online test ON**

Command: #TEST1

Response: OK

● **Online test OFF**

Command: #QUIT

Response: OK

Clearing transmission buffer

Clears data stored in the transmission buffer.

Command: BCLR

Response: OK

Shift to setting mode

Enters the setting mode. ⇨ See page 118.

Command: SSET

Response: OK

Laser off/Resetting Laser off

Turns off the laser emission when the laser beam may cause injury to an operator.

⇨ See page 4.

● **Laser off**

Command: LOCK

Response: OK

● **Resetting Laser off**

Command: UNLOCK

Response: OK

- When the Laser off command is executed, bar code read operation (laser emission) is disabled until the Laser off command is reset by using UNLOCK command.
- The Laser off command is retained even after the power is turned off.

Reset

Resets the BL-600 software.

Command: RESET

Response: OK

Readout history check

Outputs the readout OK and NG counts during trigger input ON.

Command: NUM

Response: aaaaa/bbbbb/ccccc

aaaaa = 00000 to 65535: Readout OK count

bbbbbb = 00000 to 65535: Readout NG count

ccccc = 00000 to 65535: Trigger input ON count

- These counts are reset to zero by turning the power OFF or sending the RESET command.

Motor control

Stops motor rotation.

- **Motor stop**

Command: MOTOROFF

Response: OK

- **Resetting the motor stop**

Command: MOTORON

Response: OK

- Reading is disabled for 5 seconds after the motor stop is reset.

Changing the scanning width

Changes the scanning width

- **Starting angle of scanning**

Command: SDEGa

(Specify the starting angle of scanning [angle "a"] using angle "c" as a reference.) [a = 0 to 400 (Unit: 0.1°) * Initial value = 0]

Response: OK

- **Scanning angle**

Command: WDEGb

(Specify the scanning angle starting from angle "a.") [b = 400 to 600 (Unit: 0.1°)

* Initial value = 600]

Response: OK

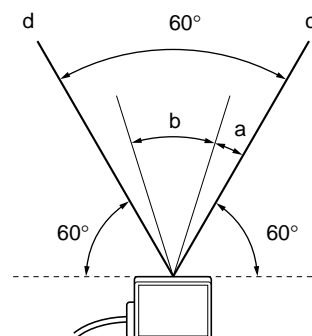

Note 1: The scanning width cannot be specified to exceed the angle range between "c" and "d" (60°).

Note 2: The angle specified in the steps above should be used as a guide. If a precise setting is required, adjust the position of each bar code reader separately after installation.

7.3.2 Details on parameter setting commands

The following describes how to change the BL-600's settings through command communication.

You can use the setup software to change the BL-600's settings instead of these commands.

Communication details

1. Send the direct control command SSET to the BL-600.
The BL-600 will shift to setting mode.
After successfully executing the command, the BL-600 sends back an OK.
2. The BL-600 Series shifts to the setting mode.
If the command is successfully executed: The BL-600 Series sends back an "OK."
3. Send the command for an item to be changed (setting change command).
If the command is successfully executed: The BL-600 Series sends back an "OK."
If an error occurs: The BL-600 Series sends back an "ERR** (**: Error code)."
4. To confirm the current settings, send a setting confirmation command.
If the command is successfully executed: The BL-600 Series sends back the setting data.
If an error occurs: The BL-600 Series sends back an "ERR** (**: Error code)."
5. To save the settings in the EEP-ROM, send "SAVE" to the BL-600 Series.
Once the settings have been saved in the EEP-ROM, the BL-600 Series will start with the new settings the next time it is turned on.
If the command is successfully executed: The BL-600 Series sends back an "OK."
If an error occurs: The BL-600 Series sends back an "ERR** (**: Error code)."
6. To quit the setting mode and perform normal bar code reading, send "SEND" to the BL-600 Series.
If the command is successfully executed: The BL-600 Series sends back an "OK."
If an incorrect command is sent: The BL-600 Series sends back an "ERR** (**: Error code)."

Communication format

When the command format is **[Command][CR]**, the response format is **[Response][CR]**. When the command format is **[STX][Command][ETX]**, the response format is **[STX][Response][ETX]**.

Command	Response
Command [CR]	Response [CR]
[STX] Command [ETX]	[STX] Response [ETX]

* <LF> can be added at the end of the command being sent. In this case, however, <LF> is not added to the response data.

Note 1: When <ESC> is added before the command being sent, characters in the BL-600's command receiving buffer are cleared.

Note 2: If the BL-600's command receiving buffer contains erroneous characters due to a data transmission error during communication, add <ESC> to the command being sent.

Note 3: For command communication, set the time duration between transmission of each character (byte) to up to 30 seconds. If this duration exceeds 30 seconds, the BL-600 cancels the received characters.

Response error code

When an incorrect command is sent to set parameters, the BL-600 sends back data indicating the cause of the error (error code). For the commands corresponding to the error codes, see the error code column given in the table on the following pages.

Error code	Cause of error
00	Undefined command.
01	Command format is incorrect.
02	Nothing corresponds to the number in the command.
03	"m" value (codes 1 to 4) is other than 0 to 3.
04	"Bar code type setting command" was not sent first. ⇨ See page 120. Sending "No. of readable digits setting command" is invalid for UPC/EAN code.
05	The number in the command is too long.
06	"hhh..." data is too short.
07	"n" value is not 0 or 1.
08	"n" value is exceeding the setting range.
09	"nnn" or "nn" value is exceeding the setting range.
10	"hhh..." is not specified in HEX (hexadecimal) code.
11	"hhh...=FF" cannot be set.
12	"hhh..." or "aaa..." contains more than the specified number of characters.
13	Characters of "aaa..." are invalid.
14	Data in the EEPROM may be damaged. Perform initial setup.
15	Error in the area storing initial settings. Settings are automatically initialized.
17	\ is not followed by !, ? or \ in preset data. ⇨ See pages 164 and 165.
18	Two !s exist in preset data. ⇨ See page 101.
99	The BL-600 may malfunction. Contact KEYENCE.

Description of parameter setting commands

■ Saving/initializing settings/quitting setting mode

Function	Command being sent	Response	Description	Error code
Saves settings in the EEP-ROM.	SAVE	OK	↪ See page 118.	—
Initializes settings.	DFLT	OK	Returns to the default-settings, and saves the settings in the EEP-ROM.	00, 05, 14, 15
Quits the setting mode.	SEND	OK	↪ See page 118.	—

■ Setting bar code type and number of readable digits for codes 1 to 4

The following describes the parameter setting commands for Codes 1 to 4. Be sure to send “Bar code type setting command” first before setting other parameters.

- * When “Bar code type setting command” is newly sent, all other parameters for the specified code will return to the default settings. In this case, set all other parameters again.

Setting change commands and setting confirmation commands are described on the following pages.

Function	Command being sent		Response	Description	Error code
Setting bar code type for codes 1 to 4. (Bar code type setting command)	Change	CODEm=n	OK	m=0 to 3: Codes 1 to 4	00, 01, 03, 05, 08, 14
	Confirm	CODEm	mn	n=0: CODE 39 1: ITF 2: Industrial 2 of 5 3: Codabar 4: UPC/EAN 5: CODE128 6: COOP2of5 7: None 8: CODE93	
Setting Max. No. of readable digits	Change	MAXm=nn	OK	m=0 to 3: Codes 1 to 4	00, 01, 03, 04, 05, 09, 14
	Confirm	MAXm	mnn	nn=01 to 32 * For CODE39, Codabar: 03 to 32 * For ITF: 02 to 32 * For CODE128: 01 to 64	
Setting Min. No. of readable digits	Change	MINm=nn	OK	Note: With EAN code, this command causes error.	
	Confirm	MINm	mnn		
CODE39 Sending start/stop character.	Change	WCm00n	OK	m=0 to 3: Codes 1 to 4	00, 02, 03, 04, 05, 07, 14
	Confirm	RCm00	00n	n=0: Disable 1: Enable	
CODE39 Inspection of check digit (Modulus 43)	Change	WCm01n	OK	m=0 to 3: Codes 1 to 4	14
	Confirm	RCm01	01n	n=0: Disable 1: Enable	

Function	Command being sent		Response	Description	Error code
CODE39 Sending check digit.	Change	WCm02n	OK	m=0 to 3: Codes 1 to 4 n=0: Disable 1: Enable	00, 02, 03, 04, 05, 07, 14
	Confirm	RCm02	02n		
ITF Inspection of check digit (Modulus 10/ Wait 3)	Change	WCm10n	OK	m=0 to 3: Codes 1 to 4 n=0: Disable 1: Enable	
	Confirm	WCm10	10n		
ITF Sending check digit.	Change	WCm11n	OK	m=0 to 3: Codes 1 to 4 n=0: Disable 1: Enable	
	Confirm	RCm11	11n		
Codabar Sending start/stop character.	Change	WCm30n	OK	m=0 to 3: Codes 1 to 4 n=0: Disable 1: Enable	
	Confirm	RCm30	30n		
Codabar Start/Stop character type	Change	WCm31n	OK	m=0 to 3: Codes 1 to 4 n=0: Lower case 1: Upper case	
	Confirm	RCm31	31n		
Codabar Inspection of check digit	Change	WCm32n	OK	m=0 to 3: Codes 1 to 4 n=0: Disable 1: Enable	
	Confirm	RCm32	32n		
Codabar Sending check digit	Change	WCm33n	OK	m=0 to 3: Codes 1 to 4 n=0: Disable 1: Enable	
	Confirm	RCm33	33n		
Codabar Setting check digit type	Change	WCm34n	OK	m=0 to 3: Codes 1 to 4 n=0: Modulus16 1: Modulus 11 2: Modulus 10/Wait 2 3: Modulus 10/Wait 3 4: 7 Check DR 5: Modulus 11-A 6: Modulus 10/ Wait 2-A	00, 02, 03, 04, 05, 08, 14
	Confirm	RCm34	34n		
EAN/UPC (A•E) Reading UPC-E	Change	WCm40n	OK	m=0 to 3: Codes 1 to 4 n=0: Disable 1: Enable	00, 02, 03, 04, 05, 07, 14
	Confirm	RCm40	40n		
EAN/UPC (A•E) Reading EAN 8 digits	Change	WCm41n	OK	m=0 to 3: Codes 1 to 4 n=0: Disable 1: Enable	
	Confirm	RCm41	41n		

Function	Command being sent		Response	Description	Error code
EAN/UPC (A•E) Reading JAN 13 digits	Change	WCm42n	OK	m=0 to 3: Codes 1 to 4 n=0: Disable 1: Enable	00, 02, 03, 04, 05, 07, 14
	Confirm	RCm42	42n		
EAN/UPC (A•E) No. of UPC-A output digits	Change	WCm43n	OK	m=0 to 3: Codes 1 to 4 n=0: Output in 13 digits 1: Output in 12 digits	
	Confirm	RCm43	43n		
EAN/UPC (A•E) Adding "0" to UPC- E system code	Change	WCm44n	OK	m=0 to 3: Codes 1 to 4 n=0: Disable 1: Enable	
	Confirm	RCm44	44n		
CODE128 EAN-128 support ⇨ See p. 32.	Change	WCm51n	OK	m=0 to 3: Codes 1 to 4 n=0: Disable 1: Enable	
	Confirm	RCm51	51n		
Setting max. code length output function	Change	WCm83n	OK	m=0 to 3: Codes 1 to 4 n=0: Disable 1: Enable	
	Confirm	RCm83	83n		
Setting direction for max. code length output	Change	WCm84n	OK	m=0 to 3: Codes 1 to 4 n=0: Forward 1: Reverse	
	Confirm	RCm84	84n		
Setting effective digits for max. code length output	Change	WCm85nn	OK	m=0 to 3: Codes 1 to 4 nn=01 to 32 : Effective digits	00, 02, 03, 04, 05, 09, 14
	Confirm	RCm85	85nn		
Setting starting digit for max. code length output	Change	WCm86nn	OK	m=0 to 3: Codes 1 to 4 nn=01 to 32 : Starting digit	
	Confirm	RCm86	86nn		
Setting label orientation speci- fied reading	Change	WCm81n	OK	m=0 to 3: Codes 1 to 4 n=0: Disable 1: Enable	00, 02, 03, 04, 05, 07, 14
	Confirm	RCm81	81n		
Setting orientation for orientation- specified reading	Change	WCm82n	OK	m=0 to 3: Codes 1 to 4 n=0: Forward 1: Reverse	
	Confirm	RCm82	82n		

■ Setting Reading Mode/Data Addition Functions

Function	Command being sent		Response	Description	Error code
Setting reading mode	Change	WP12n	OK	n=0: Single label 1: Multi label 1 2: Multi label 2 3: Multi label 3	00, 02, 05, 07, 14
	Confirm	RP12	12n		
Setting data send timing	Change	WP13n	OK	N=0: Sends data after reading 1: Sends after timing input turns off	00, 02, 05, 07, 14
	Confirm	RP13	13n		
Setting repeat-read time in multi label reading mode 1 or 2	Change	WP41nnn	OK	nnn=001 to 225 (by 100 ms step)	00, 02, 05, 09, 14
	Confirm	RP41	41nnn		
Setting decoding match count	Change	WP43nnn	OK	nnn=001 to 225	
	Confirm	RP43	43nnn		
Setting decoding match count in additional information	Change	WP10n	OK	n=0: No addition 1: Add	00, 02, 05, 07, 14
	Confirm	RP10	10n		
Setting scans in additional information	Change	WP11n	OK	n=0: No addition 1: Add Note: Effective only when No. of decodings are added.	
	Confirm	RP11	11n		
Setting label orientation in additional information	Change	WP14n	OK	n=0: No addition 1: Add	
	Confirm	RP14	14n		
Setting code type in additional information	Change	WP17n	OK	n=0: No addition 1: Add	
	Confirm	RP17	17n		
Adding a symbol identifier	Change	WP80n	OK	n=0: No addition 1: Add	
	Confirm	RP80	80n		
Adding PMI (Preventive maintenance information)	Change	WP86n	OK	n=0: No addition 1: Add	
	Confirm	RP86	86n		
PMI Preset value 1 (L1)	Change	WP48nnn	OK	nnn= 000 to 100	00, 02, 05, 07, 14
	Confirm	RP48	48nnn		
PMI Preset value 2 (L2)	Change	WP49nnn	OK	nnn= 000 to 100	
	Confirm	RP49	49nnn		
Setting reading error code	Change	WP55hhh...	OK	hhh ... = Reading error code (within 8 characters) * Specify the characters in HEX (hexadecimal) code. * If the reading error code is not specified, hhh... = FF.	00, 02, 05, 06, 10, 12, 14
	Confirm	RP55	55hhh...		

Tips

To set the reading error code, send the following command:

Example 1

Set the reading error code to “BR”.

```

      B R
      □□
WP554252
* B = 42h, R = 52h
    
```

Example 2

Set no reading error code.

```
WP55FF
```

■ **Setting trigger input (Starting test mode)**

Function	Command being sent		Response	Description	Error code
Setting signal type	Change	WP05n	OK	n=0: Level	00, 02, 05, 07, 14
	Confirm	RP05	05n	1: One-shot	
Setting one-shot input time	Change	WP42nnn	OK	nnn=001 to 225	00, 02, 05, 09, 14
	Confirm	RP42	42nnn	(by 100 ms step)	
Setting time constant of trigger input	Change	WP04n	OK	n=0: 2 ms	00, 02, 05, 07, 14
	Confirm	RP04	04n	1: 10 ms	
Setting state of trigger input	Change	WP03n	OK	n=0: Normal-open	00, 02, 05, 07, 14
	Confirm	RP03	03n	1: Normal-close	
Trigger the input status at power-on	Change	WP02n	OK	n=0: OFF	00, 02, 05, 07, 14
	Confirm	RP02	02n	1: ON	
Starting test mode when trigger input turns on. (To specify the test mode, use the command below.)	Change	WP06n	OK	n=0: Disable	00, 02, 05, 07, 14
	Confirm	RP06	06n	1: Enable	
Specifying the test mode to be started when trigger input turns on.	Change	TRGTn	OK	n=1: Reading rate check mode	00, 02, 05, 08, 14
	Confirm	TRGT	TRGTn	2: Tact check mode	
Starting test mode when power is turned on.	Change	TESTn	OK	n=0: Reset	00, 02, 05, 08, 14
	Confirm	TEST	TESTn	1: Reading rate check mode 2: Tact check mode	
Setting characters of trigger on command	Change	WP56hhh...	OK	hhh...=Trigger on command (Up to 8 characters)	00, 02, 05, 11, 14
	Confirm	RP56	56hhh...	* Specify characters in HEX (hexadecimal) code.	
Setting characters of trigger off command	Change	WP57hhh...	OK	hhh...=Trigger off command (Up to 8 characters)	00, 02, 05, 11, 14
	Confirm	RP57	57hhh...	* Specify characters in HEX (hexadecimal) code.	

Tips

To set characters of the trigger On/Off command, send the following command.

Example 1

Change the trigger on command to S.

```

      S
      □
WP5653
* S=53h

```

■ Setting communication parameters 1

Function	Command being sent		Response	Description	Error code
Setting baud rate	Change	WP35n	OK	n=5: 38400 bps 6: 31250 bps 7: 19200 bps 0: 9600 bps 1: 4800 bps 2: 2400 bps 3: 1200 bps 4: 600 bps	00, 02, 05, 08, 14
	Confirm	RP35	035n		
Setting data bit length	Change	WP30n	OK	n=0: 7 bits	00, 02, 05, 07, 14
	Confirm	RP30	30n	1: 8 bits	
Setting parity check * To set the parity type, use the command below.	Change	WP31n	OK	n=0: Disable	00, 02, 05, 07, 14
	Confirm	RP31	31n	1: Enable	
Setting parity type	Change	WP32n	OK	n=0: Even	00, 02, 05, 07, 14
	Confirm	RP32	32n	1: Odd	
Setting Stop bit	Change	WP33n	OK	n=0: 1 bit	00, 02, 05, 07, 14
	Confirm	RP33	33n	1: 2 bits	
Setting RTS/CTS handshaking	Change	WP22n	OK	n=0: Disable	00, 02, 05, 07, 14
	Confirm	RP22	22n	1: Enable	
Setting RS-485 multi drop link	Change	WP34n	OK	n=0: Disable	00, 02, 05, 07, 14
	Confirm	RP34	34n	1: Enable	
Setting ID No. for RS-485 multi drop link.	Change	WP44nn	OK	nn=01 to 31	00, 02, 05, 09, 14
	Confirm	RP44	44nn		

■ Setting communication parameters 2 (When the PLC link is not used)

Function	Command		Response	Description	Error code
Handshaking protocol 1	Change	WP07n	OK	n = 0: No handshaking n = 1: Use protocol *To set details of the protocol, use handshaking protocol 2.	00, 02, 05, 07, 14
	Confirm	RP07	07n		
Handshaking protocol 2	Change	WP08n	OK	n = 0: PASS/RTRY protocol n = 1: ACK/NAK protocol	
	Confirm	RP08	08n		
Adding checksum	Change	WP39n	OK	n = 0: Do not add n = 1: Add	
	Confirm	RP39	39n		
Header	Change	WP51hhh...	OK	hhh... = Header (up to five characters) * To set a header, use HEX (hexadecimal) codes. * hhh... = FF: Header is not set.	00, 02, 05, 06, 10, 12, 14
	Confirm	RP51	51hhh...		
Delimiter	Change	WP52hhh...	OK	hhh... = Delimiter (up to five characters) * To set a delimiter, use HEX (hexadecimal) codes. * hhh... = FF: Delimiter is not set.	
	Confirm	RP52	52hhh...		
Transmission delay time	Change	WP98nnn	OK	nnn = 000 to 255 (by 10 ms step)	00, 02, 05, 09, 14
	Confirm	RP98	98nnn		

7

Tips

To set the header and delimiter, send the following command:

Example

Set the communication data format to <SOH> 0I bar code data A <CR>.

```

      SOH  0  I
      └──┬──┴──┬──┬──┘
      WP5101303I
      A  CR
      └──┬──┘
      WP52410D
  
```

* SOH=01h, 0=30h, I=31h, A=41h, CR=0Dh

■ Setting communication parameters 2 (only when PLC link is used)

Function	Command		Response	Description	Error code
PLC link model	Change	WP36n	OK	n = 0: PLC link disabled n = 1: SYSNAC-C n = 2: MELSEC-A n = 3: KV n = 4: MELSEC-A (File register is used.)	00, 02, 05, 07, 14
	Confirm	RP36	36n		
Trigger input through PLC link	Change	WP37n	OK	n = 0: Disable n = 1: Enable	
	Confirm	RP37	37n		
DM head address	Change	WP45nn	OK	nn = 00 to 99 (0000 to 9900)	00, 02, 05, 09, 14
	Confirm	RP45	45nn		
PLC / station number	Change	WP47nn	OK	nn = 00 to 31	
	Confirm	RP47	47nn		
File register block number	Change	WP46nnn	OK	nnn = 000 to 255	
	Confirm	RP46	46nnn		

■ Setting communication strings

Function	Command		Response	Description	Error code
Setting partition mark when additional information is used.	Change	WP50hh	OK	hh = Partition mark (1 character) * Specify the mark in HEX (hexadecimal) code.	00, 02, 05, 06, 10, 12, 14
	Confirm	RP50	50hh		
Setting intermediate delimiter when multi label reading mode 2 or 3 is used.	Change	WP54hhh...	OK	hhh = Intermediate delimiter (Up to 5 characters) * Specify the mark in HEX (hexadecimal) code. * To set no intermediate delimiter, hhh = FF.	
	Confirm	RP54	54hhh...		

■ Utility Setting (Stability LED, OK/NG output duration, Preset data for compare)

Function	Command being sent		Response	Description	Error code
Indication of Stability LED	Change	WP09n	OK	n=0: Disable	00, 02, 05, 07, 14
	Confirm	RP09	09n	1: Enable	
Setting OK/NG output duration	Change	WP40nnn	OK	nnn= 001 to 255	00, 02, 05, 09, 14
	Confirm	RP40	40nnn	(by 10 ms step)	
Registration of preset data for compare	Change	WP68aaa...	OK	aaa...= Preset data	00, 02, 05, 12, 13, 14, 17, 18
	Confirm	RP68	68aaa...	(Up to 32 characters) * For CODE128, see P.136 to 137. * To delete the preset data, send WP68.	
Scaling factor for the quiet zone	Change	WP0Mn	OK	n = 0: 4x	00, 02, 05, 07, 14
	Confirm	RP0M	0Mn	1: 5x 2: 6x 3: 7x 4: 8x 5: 9x 6: 10x 7: 11x	
Reading a reversed bar code	Change	WP0Rn	OK	n= 0: OFF	
	Confirm	RP0R	0Rn	1: On	
Outputting the test mode result	Change	WP85n	OK	n = 0: Disable output	
	Confirm	RP85	n	1: Enable output	
Changing the decoding match count	Change	WP93nnn	OK	nnn= 000 to 255	
	Confirm	RP93	93nnn		

Tips

To register the preset data, send the following command.

Example

Register "ABC123" as preset data.

WP68ABC123

Chapter 8

PLC Link

This chapter describes the PLC link control.

8.1	PLC Link	130
8.1.1	List of PLCs used for PLC link	130
8.1.2	Devices used for PLC link	131
8.2	Setting the BL-600 and PLC	132
8.2.1	Setting the BL-600 Series	132
8.2.2	Setting the PLC	132
8.3	Device Assignment	135
8.3.1	Data memory head address	135
8.3.2	Data memory areas	136
8.3.3	Detailed description of device assignment	137
8.4	PLC Link Error	142
8.5	Communication Time	143

8.1 PLC Link

This section describes the applicable PLCs and devices for the PLC link.

Since the BL-600 directly controls the PLC's memory, no program is required for data communication, resulting in a reduced number of programming steps.

As compared with the serial communication using a computer, the PLC link involves the following limitations:

- The BL-600 settings cannot be changed because the PLC link cannot send a command to the BL-600. However, the PLC link provides a reading control address to start/end reading.
- The PLC link cannot start the test mode.

8.1.1 List of PLCs used for PLC link

KEYENCE KV Series	Built-in CPU port	KV-10/16/24/40/80, KV-300 NEW KV-10/16/24/40
	Serial interface module	KV-L2
Mitsubishi MELSEC-A Series	Built-in CPU port	A2CCPUC24, A2CCPUC24-PRF
	Calculator link unit	AJ71(U)C24(-Sx), AJ71Q24(-R2/R4), A0J2-C214-S1 A1SJ71(U)C24-R2/PRF/R4
OMRON SYSMAC-C Series	Built-in CPU port	C20H/28H/40H C200HS-CPU21/23/31/33 C200HE-CPU/32/42 C200HG-CPU33/43/53/63 C200HX-CPU34/44/54/64 C200HX-CPU65-Z/85-Z
	High-order link unit	C200H-LK201(-V1), C500-LK203 C500-LK201-V1, C120-LK201-V1 C200H-LK202(-V1), C120-LK202-V1
	Communication board	C200HW-COM02/COM03/COM04/ COM05/COM06
OMRON SYSMAC-CQM1 Series	Built-in CPU port	CQM1-CPU21/41/42/43/44
OMRON SYSMAC-CV Series	Built-in CPU port	CV500/1000, CV-M1
	High-order link unit	CV500-LK201

Note: KV-300 and KV-L2 are not available in Europe.

8.1.2 Devices used for PLC link

The BL-600 supports the following PLC devices.

To use MELSEC-A Series, select the data register or file register.

PLC	Device name	Memory area
KV-10/16	Data memory	DM0000 to DM0999
KV-24/40/80 NEW KV-10/16/24/40	Data memory	DM0000 to DM1999
KV-300	Data memory	DM0000 to DM8999
MELSEC-A	Data register	D0000 to D8191
	File register	R0000 to R8191 (according to the setting)
SYSMAC-C	Data memory	DM0000 to DM6143

- * The available memory areas of the MELSEC-A or SYSMAC-C may be smaller than the following data.
For details, see the instruction manual for the PLC being used.
- * The MELSEC-A Series provides an extension file register.
- * When a block number is specified during the BL-600 setup, the specified extension file register is used.
When "0" is specified for the block number, the extension file register of the block number specified in the PLC program is used.
If no block number is specified (during the BL-600 setup and PLC programming), the file register incorporated in the CPU is used.

Note: KV-300 is not available in Europe.

8.2 Setting the BL-600 and PLC

This section describes setting the BL-600 Series and the PLC.

8.2.1 Setting the BL-600 Series

Use the BL-600 setup software to set the following. For the differences in setting due to the link unit or PLC type, see the next subsection "Setting the PLC".

1. In [[Comm settings-1]], set the following data.
 - Match the baud rate, data length, parity and stop bit length of the BL-600 to those of the PLC.
 - Disable the RTS/CTS protocol.
 - Disable the multi-drop link.
2. In [[Comm settings-2]], set the following data.
 - Type of the PLC
When using the KV-L2* in "Display interface mode", set "SYSMAC-C" in the BL-600 settings.
 - PLC trigger input area
 - DM head address
 - PLC unit No./station No.
 - Set whether or not the final register is used.

8.2.2 Setting the PLC

Set the PLC or link unit as follows:

■ Setting MELSEC-A Series

1. Set the RS-232C communication parameters (baud rate, data length, parity and stop bit length) according to the BL-600's settings.
2. Set the station number according to the BL-600's setting.
3. Set the mode to "Protocol Type 4".
* Only for the AJ71QC24, set the mode to "Special protocol", "ASCII", and "Type4".
4. Set the main channel to either "RS-232C" or "RS-422A".
5. Set "Checksum" to "Enable".
6. Set "Write during running" to "Enable".
7. Set "Selecting computer link/multi-drop" to "Computer link" (for the AJ71UC24 only).

■ Setting SYSMAC-C Series

1. Set the RS-232C communication parameters (baud rate, data length, parity and stop bit length) according to the BL-600's settings.
 2. Set the unit number according to the BL-600's setting.
 3. Set the command level to "Level 1, 2, 3".
 4. Set "1:1/1:N" to "1:N".
 5. Set "I/O port" to either "RS-232C" or "RS-422A".
 6. Set "Trigger input" to "Internal".
 7. Set "Supply 5 V" to "Disable".
 8. Set "CTS" to "0 V (Normally ON)."
- * The "I/O port", "Trigger input", "Supply 5 V" and "CTS" parameters may not be provided depending on the type of link unit.
- * If using the C200HE/HG/HX or a communication board, follow steps 1 and 2 above, and set the mode to "Upper link", and "CTS control" to "None". Use the initial settings for the other parameters.

■ Setting KV Series/handheld programmer port

1. The KV series' RS-232C port must always be set to the following values:
 - Baud rate : 9600 bps
 - Data length: 8 bits
 - Parity: Even
 - Stop bit length: 1 bit
 2. Set the RS-232C communication parameters of the BL-600 according to the above settings. Set the BL-600's communication mode to "KV".
- * No other parameters need to be set.

■ Settings for KV-L2/KV mode*

1. Set the KV-L2's communication mode to "KV mode".
Set the BL-600's communication mode to "KV".
2. The KV mode must be always set to the following values:
 - Baud rate : 9600 bps
 - Data length: 8 bits
 - Parity: Even
 - Stop bit length: 1 bit

Set the RS-232C communication parameters of the BL-600 according to the above settings.

3. Set the station number to "00".
 4. To use the KV-L2 port 2, set the port 2 selector switch to "RS-232C" or "RS-422A".
- * No other parameters need to be set.

Note: KV-L2 is not available in Europe.

■ **Settings for KV-L2/Display Interface mode***

1. Set the KV-L2's communication mode to "Display Interface" mode. To use link mode, select "SYSMAC-C" for the BL-600's setting.
 2. Set the baud rate, data length, parity and stop bit length according to the RS-232C communication parameters of the BL-600.
 3. Set the station number to "00".
 4. To use the KV-L2 port 2, set the port 2 selector switch to "RS-232C" or "RS-422A".
- * No other parameters need to be set.

8.3 Device Assignment

The data areas used to control the BL-600 are provided in the PLC's internal memory (D areas or DM areas).

When a device head address is specified on the "PLC SETUP" screen in the BL-600 setup software, the device numbers are automatically assigned based on the specified head address.

8.3.1 Data memory head address

[Specified head address] +00 indicates the area where the bar code data is stored. [Specified head address] +01 to +03 are reserved areas and cannot be assigned for the bar code data.

[Specified head address] +04 to +06 are the areas used by the PLC to send a reading trigger to the BL-600.

- * The method for using the areas varies depending on the BL-600 scan method, "Level signal trigger" or "One-shot signal trigger".
- * If the BL-600 Series is set to disable the "PLC Trigger Area", data is not assigned to the data memory head address area. You can use this area for other purposes.

Address	Description	Reference page
+00	Data memory head address for Code 1	137
+01	Reserved area for Code 2	137
+02	Reserved area for Code 3	137
+03	Reserved area for Code 4	137
+04	Reading trigger area	137 to 139
+05	Reading trigger response area * Only when "Level signal trigger" is selected.	
+06	One-shot trigger time setup area * Only when "One-shot signal trigger" is selected.	

Note 1: When using the BL-600 in multi-label read mode 3, addresses +00 to +03 are used as the data memory head addresses for Codes 1 to 4, respectively. Data is not stored in the areas for which the code type is not set.

Note 2: If using the BL-600 Series in multi-label read mode 1 or 2, the read data is written one at a time to the area specified with address +00 in the order of the reading.

8.3.2 Data memory areas

Bar code data read by the BL-600 is stored in the areas starting from “+00”. (Based on the specified data memory head address).

“A” indicates the data memory head address

Address	Description	Reference page
A+00	Data memory flag area	139 to 140
A+01	Label orientation	140
A+02	Decoding count/PMI	
A+03	Scan count	
A+04	Bar code type	141
A+05	Number of digits of bar code data	
A+06	1st digit of bar code data	
A+07	2nd digit of bar code data	
A+08	3rd digit of bar code data	
:	:	
A+69	64th digit of bar code data	

Note: The data memory areas accept up to 64 digits. However, the BL-600 Series can only read a maximum of 32 digits. It can only read 64 digits if the bar code type is CODE128 and the start character is CODE-C.

Example

When the bar code types are set in Codes 1 to 3 in multi-label read mode 3 (Code 4 is not set)

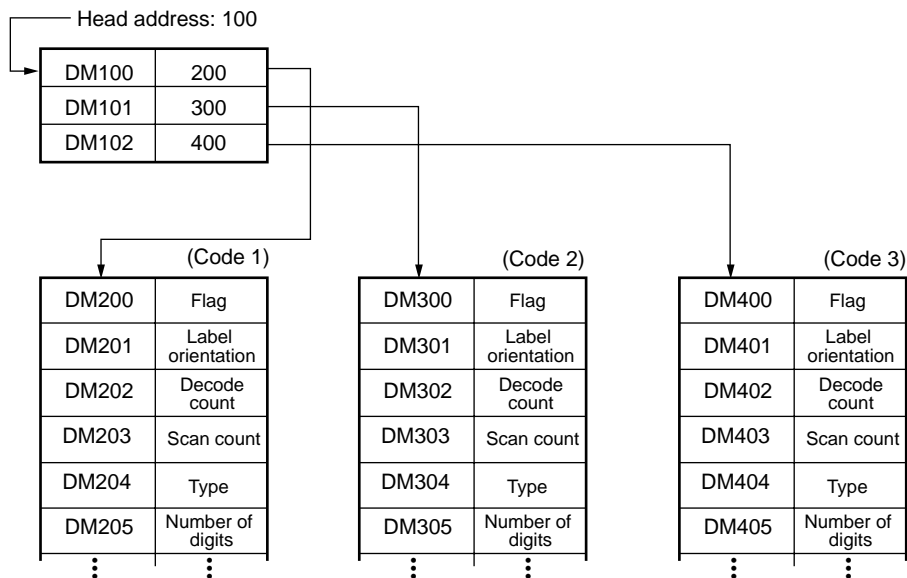

8.3.3 Detailed description of device assignment

+00 to +03

Data memory head address

Specify the head address of the areas where the read data is stored.

* Specify the head address as binary data.

Note: When using the BL-600 in multi-label read mode 3, +00 to +03 are used as the data memory head address for Codes 1 to 4, respectively. However, data is not stored in the area for which the code type is not set.

+04 to +06

Reading trigger area

These areas are used to send the trigger input signal to the BL-600 to start reading bar code data.

* If the BL-600 Series is set to disable the “PLC Trigger Area”, data is not assigned to the data memory head address area. You can use this area for other purposes.

Note: When connecting a photoelectric sensor for trigger input in the BL-600 Series, do not use these areas.

The method for using the areas varies depending on the BL-600 scan method, “Level signal trigger” or “One-shot signal trigger”. Each case is described below.

■ **When “Level signal trigger” is set**

- “Reading trigger area” at the +04 address is used to trigger the BL-600 to start reading the data (turn on the laser beams).
- “Trigger input response area” at the +05 address is used to check whether the data at +04 was sent correctly to the BL-600. When the BL-600 recognizes the +04 address (which means that the process has been completed), it returns a “1” to the +05 address.

Address	Description	Data
+04	Reading trigger area	1 ... Trigger ON 0 ... Trigger OFF
+05	Trigger input response area	1 ... Process completed 0 ... Process not completed
+06	Reserved	Reserved

Operating procedure

1. Set the +05 address to "0".
2. To trigger the BL-600 to start reading (to turn the trigger ON), set the +04 address to "1".
3. When the BL-600 recognizes the change in the +04 address, it returns a "1" to the +05 address. The BL-600 then starts reading the data.
If a "1" is not returned, the BL-600 has not recognized the +04 address yet. Do not immediately reset the +04 address to "0".
After confirming that a "1" has been returned to the +05 address, reset the address to "0".
4. After reading the bar code data, the BL-600 writes new data in A+05 to A+69.
5. To turn the trigger OFF, reset the +04 address to "0".
6. When the BL-600 recognizes the change in the +04 address, it returns a "1" to the +05 address. The trigger then turns OFF.
If a "1" is not returned, the BL-600 has not recognized the +04 address yet. Do not immediately set the +04 address to "1".
After confirming that the +05 address has been set to "1", reset the address to "0".
7. If a reading error occurs, a reading error code is written in A+05 to A+69.

Note: When quickly turning the trigger ON/OFF at the +04 address, the BL-600 may overlook the change in the +04 address and fail to turn the trigger ON/OFF. If this occurs, change the program so that the +05 address can confirm that the BL-600 recognized the +04 address.

If your system does not have the problem described above, monitoring by the +05 address is not required.

■ One-shot signal trigger

- The +04 address "Reading trigger area" triggers the BL-600 to start reading (turn ON the laser).
- The +06 address "One-shot signal trigger time setup area" sets the scan time in one-shot signal mode. *See page 86.*
When "0" is set for this address, the value set by the BL-600 setup software is used as the scan time.

Address	Description	Data
+04	Reading trigger area and response area	1: Trigger ON 0: Trigger OFF
+05	Reserved	Reserved
+06	One-shot signal trigger time setup area	0: Use the value set by the BL-600 setup software. 1 to 255 (binary) : 100 ms to 25.5 s

* When the BL-600 recognizes "1", "0" is set to the +04 address.

Operating procedure

1. To trigger the BL-600 to start reading, set the +04 address to "1".
2. When the BL-600 recognizes the +04 address, it returns a "0" to the +04 address. The BL-600 then starts reading the data.
3. The BL-600 continues reading for the "one-shot signal trigger time" set at the +06 address.
4. When the BL-600 has read all the bar codes, it writes the new data in A+05 to A+69.
5. If a reading error occurs, the BL-600 writes a reading error code in A+05 to A+69.

A+00 (A is the head address in which the data specified in +00 to +03 is stored.)
--

Memory data flag areas

The memory data flag areas are used to flag that the bar code data has been stored.

The following two methods are available depending on the application.

■ Real-time processing

- A number of "0" or "1" is written to the memory data flag area.
- While the BL-600 is reading and writing the bar code data in the PLC's memory, the flag area is set to "1".
- When new data is stored in addresses A+05 to A+69, address A+00 becomes "0". In other words, new data is the data when address A+00 changes from a "1" to a "0".
- If the bar code reading interval of the BL-600 Series is shorter than that of the communication in the PLC link, data that has not been written into the specified area is stored in the transmission buffer of the BL-600 Series. ⇨ See page 6-5. If the amount of stored data exceeds the capacity of the buffer, the entire contents of the buffer is cleared and an "OVER" is stored in the memory data area (A+05 to A+09).
If an overflowed buffer error occurs, the BL-600 Series halts operation. It will resume operation once the "OVER" has been stored.

Example 1

Normally, the A+00 address is set to "0".

While the BL-600 is writing data, the flag area is "1". When the flag area becomes "0", the data stored in the A+05 to A+69 addresses can be processed.

Example 2

Normally, the A+00 address is set to "1".

When data writing is completed, the flag area becomes "0". The data stored in the A+05 to A+69 addresses can be processed.

Set the A+00 address to "1" immediately after data processing is completed. This enables the BL-600 to use the point at which the A+00 address becomes "0" as the trigger for writing new data.

Note: When the BL-600 continuously reads bar codes, the real time processing mode may replace stored data with new data before the new data is processed in the PLC. To prevent this, use the sequential processing mode as shown in the next page.

■ Sequential processing

- A number of “2” or “3” is written to the memory data flag area.
- When the A+00 address is “2”, new data can be stored.
- When data writing is completed, the flag area becomes “3”, and new data has been stored in the A+05 to A+69 addresses.
- After data processing is completed, set the flag area to “2”. Writing new data is impossible until the flag area is set to “2”.
- Data that has not been written into the specified area is stored in the transmission buffer of the BL-600 Series. ⇨ See page 112. If the amount of stored data exceeds the capacity of the buffer, the entire contents of the buffer is cleared and an “OVER” is stored in the memory data area (A+05 to A+09).
When an overflowed buffer error occurs, the BL-600 Series halts operation. It will resume operation once the “OVER” has been stored.

Note: If the PLC link communication is not established or the memory data flag area stores data other than a “0” or a “2” at the occurrence of an overflowed buffer error, the BL-600 Series stops all operation because the “OVER” cannot be stored. (Laser emission is disabled even if the trigger input turns on.)
In this case, check the settings and wiring of the BL-600 Series and the PLC, and the PLC program.

A+01 to A+04
Additional data area

The label orientation, decode count and other additional data are stored in these areas.

Address	Description	Data
A+01	Label orientation	0: Reading error 1: Formal orientation 2: Reverse orientation
A+02	Decode count	0 to 9999 (binary)
A+03	Scan count	0 to 9999 (binary)
A+04	Bar code type	0: CODE 39 1: ITF 2: Industrial 2of5 3: Codabar 4: EAN/UPC 5: CODE128 6: COOP 2of5 7: Reading error 8: CODE 93

If PMI is added, only A+02 and A+03 store the following data.

Address	Description	Data
A+02	PMI (Preventive Maintenance Information)	0: Normal 1: Caution 2: Warning 9: Reading error
A+03	Reserved	Reserved

A+05 to A+69

Data memory area

- The number of digits of the data is stored in the +05 address.
- The read bar code data is stored in the A+06 to A+69 addresses using the ASCII codes (hexadecimal numbers in two digits) by the digit.
 - ⇨ See the ASCII code table on page 169.
- If a read error occurs, the “ERROR” code is stored in the corresponding area. (The reading error code can be easily changed in the BL-600 settings.)
 - ⇨ See page 43.
- If a buffer overflow error occurs with the BL-600, the “OVER” code is stored in the corresponding area.
- If an error occurs in the main unit, the “MOTOR” code is stored in the corresponding area.

Address	Description	Data
A+05	Number of digits of bar code data (1 to 64)	1 to 64 (binary) ... Number of digits
A+06	1st digit of read data	A single ASCII code
A+07	2nd digit of read data	A single ASCII code
:	:	:
A+69	64th digit of read data	A single ASCII code

Note 1: When test mode is enabled, the BL-600 does not write data.

Note 2: These data areas accept up to 64 digits. However, the BL-600 can read only 32 digits. When the bar code type is CODE128 and the start character is CODE-C, up to 64 digits can be read.

Example

When the BL-600 reads the bar code “KE12”

A+05	4	← Number of digits Stored in ASCII codes (hexadecimal)
A+06	\$004B	
A+07	\$0045	
A+08	\$0031	
A+09	\$0032	

Example

When the BL-600 generates a reading error (ERROR)

A+05	5	← Number of digits Stored in ASCII codes (hexadecimal)
A+06	\$0045	
A+07	\$0052	
A+08	\$0052	
A+09	\$004F	
A+10	\$0052	

8.4 PLC Link Error

This section describes the remedy if a communication error occurs during the PLC link.

If an error occurs, the BL-600 Series stops communication. The top LED in the STABILITY indicator flashes.

1. Check the following points and eliminate the cause.
 - 1) Check if the RS-232C communication parameters (baud rate, data length, parity and stop bit length) for the PLC are matched with the N-400's settings.
 - 2) Check if the PLC link is set to "Use" in the communication parameters 2 setup.
 - 3) Check if the PLC's settings are correct. ⇨ See pages 132 to 134.
 - 4) Check if the cable connections are correct, or if any cable is disconnected. Referring to chapter 2 of this manual, check the connections using a multimeter.
 - 5) Check if the device setting range does not exceed the available data memory areas of the PLC.
If the data memory areas used for the BL-600 do not exist in the PLC, communication is impossible.
 - 6) Check if the link unit operates normally.
- * For the settings of the link unit, see the instruction manual for the link unit being used.
2. Press the TEST switch of the BL-600 Series.
Communication recovers.

If the problem cannot be solved in the procedure above, contact your nearest KEYENCE office or distributor (listed at the end of this manual).

8.5 Communication Time

This section describes the communication time required for data transmission between the BL-600 Series and the PLC.

■ Time required data transmission

The time required for data transmission from the BL-600 to the PLC is as follows: This communication time may change depending on the PLC's scan time and the model of the PLC.

* When the RS-232C communication baud rate is 9600 bps:

Number of data digits	MELSEC-A	SYSMAC-C	KV (KV mode)
10	Approx. 220 ms	Approx. 330 ms	Approx. 440 ms
20	Approx. 270 ms	Approx. 380 ms	Approx. 680 ms
32	Approx. 320 ms	Approx. 460 ms	Approx. 920 ms

■ Communication time to start reading using reading trigger area

To control the BL-600 Series' reading operation using the reading trigger area, enter the trigger ON command on the PLC, and obtain the time duration until the command is received by the BL-600.

* When the RS-232C communication baud rate is 9600 bps:

MELSEC-A	SYSMAC-C	KV (KV mode)
Approx. 60 ms	Approx. 80 ms	Approx. 30 ms

Appendices

The appendix includes specifications, reading characteristics, dimensions, troubleshooting, and index.

Appendix A	BL-600 Series Specifications	146
Appendix A.1	Specifications	146
Appendix A.2	Reading range characteristics (Typical)	148
Appendix A.3	Angular characteristics (Typical)	151
Appendix B	BL-U1 Specifications	152
Appendix C	BL-U2, N-42 Specifications	153
Appendix D	Dimensions	154
Appendix E	Sample Program for the PLC Link	159
Appendix F	Troubleshooting	162
Appendix F.1	Bar codes cannot be read	162
Appendix F.2	Reading rate check mode is not 100%	163
Appendix F.3	The setting data cannot be sent/received using the setup software	163
Appendix F.4	Cannot communicate successfully when using the PLC link	163
Appendix G	CODE93 Specifications	164
Appendix H	CODE128 Specifications	165
Appendix I	Checksum Calculation Method	167
Appendix J	ASCII Code Table	169
Appendix K	Setup Parameter List	170
Appendix L	Default Setting List	173

Appendix A BL-600 Series Specifications

Appendix A.1 Specifications

■ General specifications

Model	BL-600	BL-601	BL-600HA	BL-601HA	BL-650HA	BL-651HA
Type	Standard type		High-resolution		High-resolution, side-scanning type	
Scanning direction	Front				Side	
Light source	Visible red semiconductor laser (Wavelength: 650 nm)					
Maximum output	1.5 mW					
Pulse width	99 μs				82 μs	
Class	FDA		Class II			
IEC 825-1 11.1993			Class 2			
DIN EN 60825-1 07.1994			Klasse 2			
Scan method	Single	Raster	Single	Raster	Single	Raster
Reading distance	75 to 330 mm (When narrow width is 1.0 mm)		55 to 190 mm (When narrow width is 0.5 mm)		45 to 175 mm (When narrow width is 0.5 mm)	
Reading bar width ¹ :	0.19 to 1.0 mm * 0.25 to 1.0 mm for CODE93 and CODE128		0.125 to 1.0 mm * 0.15 to 1.0 mm for CODE93 and CODE128			
Maximum reading label width ² :	250 mm (When reading distance is 280 mm)		156 mm (When reading distance is 174 mm)		170 mm (When reading distance is 155 mm)	
PCS	0.6 or more (white reflection rate 75% or more)					
Scan count	500 scans/second					
Supported codes	CODE39, ITF, Industrial2of5, COOP2of5, Coda bar, CODE128, EAN-128, CODE93, EAN / UPC(A•E)					
Reading digit	32 digits max. ³					
Enclosure rating	IP-65					
Ambient light	Sunlight: 10000 lx Incandescent lamp: 6000 lx					
Ambient temperature	0 to 45°C (32 to 113°F), No freezing					
Relative humidity	35 to 85%, No condensation					
Operating atmosphere	No dust or corrosive gas present					
Vibration	10 to 55 Hz, amplitude 1.5 mm, 2 hours each in X, Y and Z directions.					
Power supply voltage	5 V DC ±5%					
Power consumption	330 mA max.					
Weight	Approx. 115 g				Approx. 130 g	

1. Reading bar width indicates the range of readable narrow bar width when the bar code type is CODE39.
2. Maximum reading label width includes the bar code margin (quiet zone).
3. When start/stop character of CODE128 is CODE-C, up to 64 digits are allowed.

Note: The internal BL settings are written to the built-in EEPROM (erasable up to 100,000 times).

■ Interface specifications

Trigger input		Non-voltage input (relay contact, solid state) * TTL input is also available.
OK/NG output	Output type	NPN open collector
	Rating load	24 V DC, 30 mA
	Leakage current at OFF	0.1 mA max.
	Residual voltage at ON	0.5 V max.
Serial interface	Applied standard	In accordance with RS-232C
	Synchronization	Start-stop synchronization
	Transmission code	ASCII code
	Baud rate	600, 1200, 2400, 4800, 9600, 19200, 31250, 38400 bit/s
	Data length	7/8 bits
	Parity check	None/even/odd
	Stop bit length	1/2 bits

■ Raster width specification

In raster scan mode, the BL-600 scans multiple positions of the bar code by swinging the laser beams up and down. Thus, the bar code can be read even if it has a stain or missing part.

For the up-down width of raster scan (raster width), see the table below.

Model	Reading distance	Raster width
BL-601	120 mm	7.1 ±1.8 mm
BL-601H	90 mm	5.5 ±1.4 mm
BL-651H	65 mm	5.5 ±1.4 mm

Appendix A.2 Reading range characteristics (Typical)

■ BL-600/601

Unit: mm

	Bar code type	Narrow bar width	Reading distance
A	CODE39	0.19	90 to 160
B	CODE39	0.25	75 to 200
C	CODE39	0.5	75 to 290
D	CODE39	1.0	75 to 330

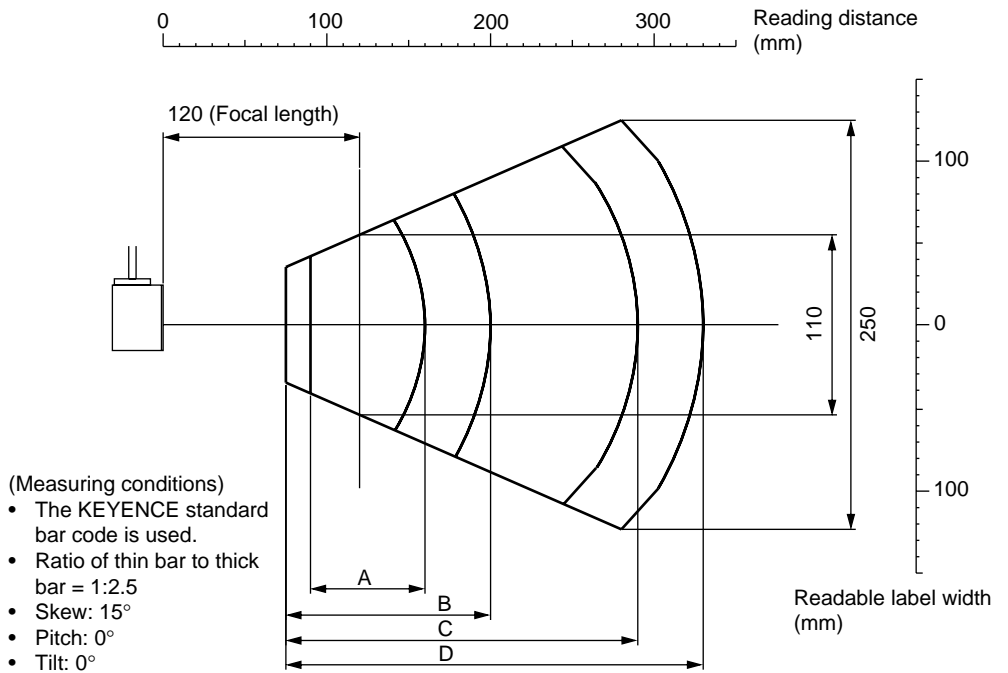

* For the reading distance measuring reference, see page 74.

Note 1: The readable label width means a bar code length including the right and left margins (quiet zones) of a bar code.

Note 2: Even if a bar code is within the above reading range, it may not be read depending on the bar code quality. Set the optimum reading position based on enough reading tests.

Note 3: It is recommended that the focal length (120 mm) is set as the mounting distance. In this case, the maximum readable label width is 110 mm.

■ BL-600HA/601HA

Unit: mm

	Bar code type	Narrow bar width	Reading distance
A	CODE39	0.125	70 to 105
B	CODE39	0.19	60 to 140
C	CODE39	0.25	55 to 150
D	CODE39	0.5	55 to 190

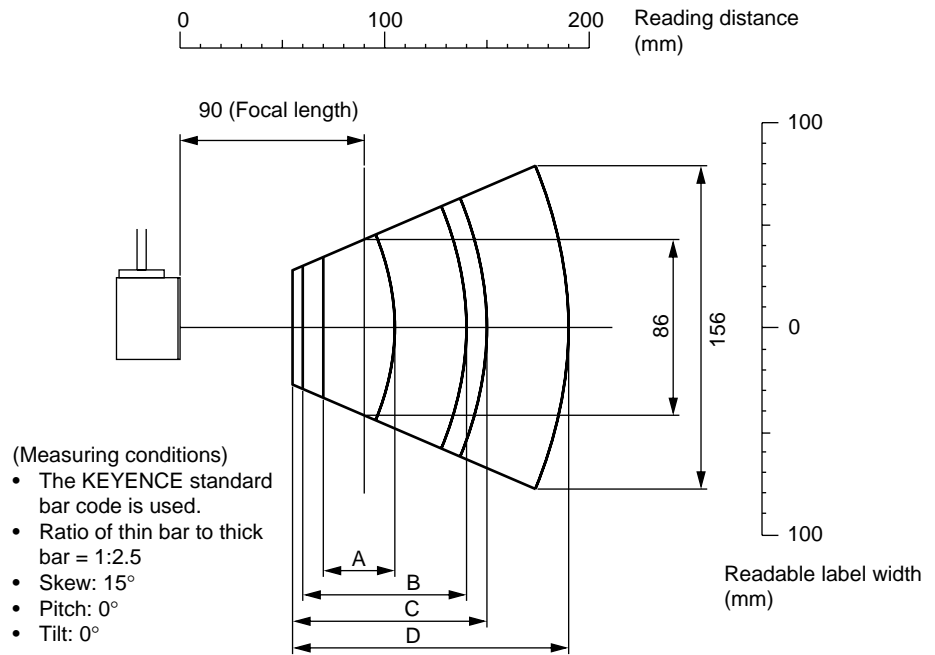

* For the reading distance measuring reference, see page 74.

Note 1: The readable label width means a bar code length including the right and left margins (quiet zones) of a bar code.

Note 2: Even if a bar code is within the above reading range, it may not be read depending on the bar code quality. Set the optimum reading position based on enough reading tests.

Note 3: It is recommended that the focal length (90 mm) is set as the mounting distance. In this case, the maximum readable label width is 86 mm.

■ BL-650HA/651HA

Unit: mm

	Bar code type	Narrow bar width	Reading distance
A	CODE39	0.125	45 to 85
B	CODE39	0.19	45 to 125
C	CODE39	0.25	45 to 140
D	CODE39	0.5	45 to 175

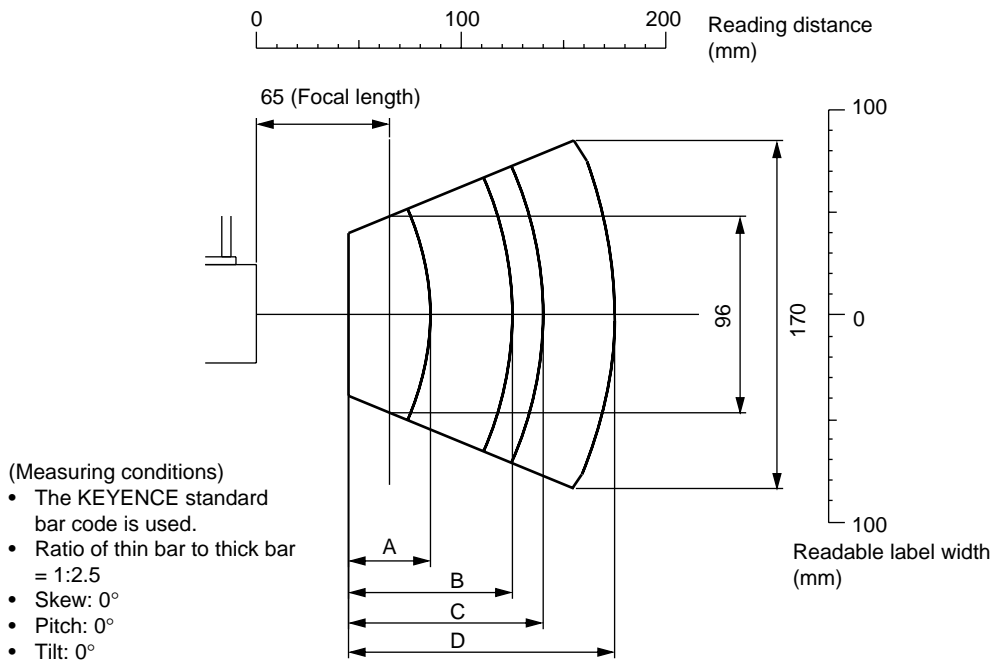

* For the reading distance measuring reference, see page 74.

Note 1: The readable label width means a bar code length including the right and left margins (quiet zones) of a bar code.

Note 2: Even if a bar code is within the above reading range, it may not be read depending on the bar code quality. Set the optimum reading position based on enough reading tests.

Note 3: It is recommended that the focal length (65 mm) is set as the mounting distance. In this case, the maximum readable label width is 96 mm.

Appendix A.3 Angular characteristics (Typical)

Model	Narrow bar width	Skew	Pitch	Tilt
BL-600/601	0.19 mm	-60° to -10°, -10° to +60°	±40°	±50°
	0.5 mm	-60° to -10°, -10° to +60°	±50°	±50°
BL-600HA/601HA	0.125 mm	-60° to -10°, -10° to +60°	±30°	±50°
	0.25 mm	-60° to -10°, -10° to +60°	±50°	±50°
BL-650HA/651HA	0.125 mm	-80° to -30°, -10° to +40°	±40°	±50°
	0.25 mm	-80° to -30°, -10° to +40°	±50°	±50°

Measuring conditions

- Bar code: KEYENCE standard bar code
- Reading distance: 120 mm (BL-600/601)
90 mm (BL-600HA/601HA)
65 mm (BL-650HA/651HA)

Note: The skew angle of -10° to +10° (-30° to -10° in BL-650HA/651HA) is the specular reflection range. In this range, bar codes cannot be read, or reading error may occur. Be sure not to mount the BL-600 Series at the above skew angles.

Skew

BL-600/601/600HA/601HA

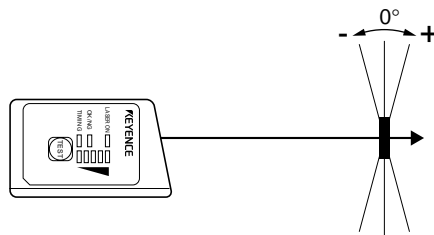

BL-650HA/651HA

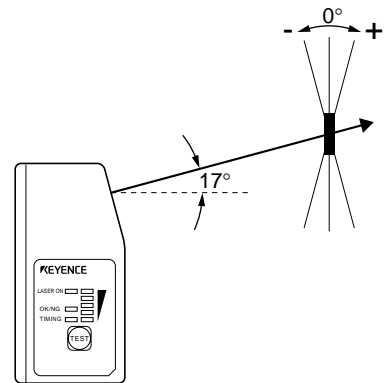

Pitch

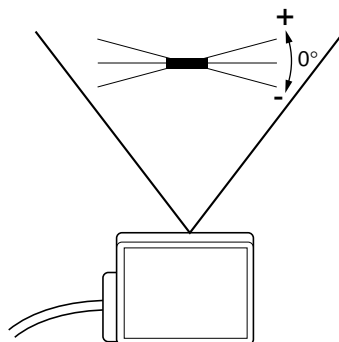

Tilt

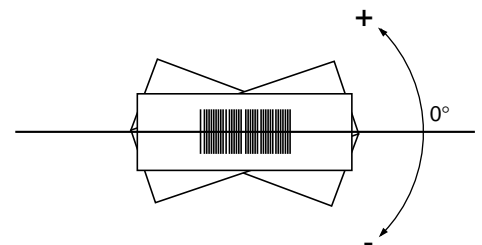

Appendix B BL-U1 Specifications

Model		BL-U1
Power supply for bar code reader		5 V DC±5% (1.5 A)
Power supply for sensor		12 V DC ±10% (300 mA)
Trigger input	Input rating	8.5 to 30 V DC, 10 mA max.
	Max. OFF current	0.5 mA
OK/NG output	Output type	NPN open-collector
	Rated load	30 V DC, 100 mA
	Leakage current (at OFF)	0.1 mA max.
	Residual voltage (at ON)	1 V max.
Interface		RS-232C, RS-422A, RS-485 multidrop (Up to 31 units can be connected. Max. cable extension: 1.2 km)
Ambient temperature		0 to 50°C (32 to 122°F), No freezing
Relative humidity		35 to 85%, No condensation
Ambient atmosphere		No dust, no corrosive gas
Vibration		10 to 55 Hz, 1.5 mm double amplitude in X, Y and Z directions, 2 hours respectively
Noise immunity		1000 V p-p, 1 μs (Power line)
Power supply voltage		100 to 240 V AC (50/60 Hz)
Current consumption		40 VA (100 V AC), 50 VA (240 V AC)
Weight		Approx. 615 g (including cable)

Appendix C BL-U2, N-42 Specifications

Model		BL-U2	N-42
Power supply for bar code reader		5 V DC $\pm 5\%$ (630 mA)	
Trigger input	Input rating	15 to 26V DC, 10 mA max.	
	Maximum OFF current	1.0 mA	
OK/NG output	Output type	NPN open-collector	
	Rated load	30 V DC, 100 mA	
	Leakage current (at OFF)	0.1 mA max.	
	Residual voltage (at ON)	1 V max.	
Interface		Conforms to EIA RS-232C.	RS-422A (Maximum extension distance: 1.2 km)
Ambient temperature		0 to 50°C (32 to 122°F), No freezing	
Relative humidity		35 to 85%, No condensation	
Ambient atmosphere		No dust, no corrosive gas	
Vibration		10 to 55 Hz, 1.5 mm double amplitude in X, Y, and Z directions, 2 hours respectively	
Power supply voltage		24 V DC $^{+10\%}_{-20\%}$	
Current consumption		250 mA max.	260 mA max.
Weight		Approx. 80 g	Approx. 100 g

Appendix D Dimensions

■ BL-600/601/600HA/601HA

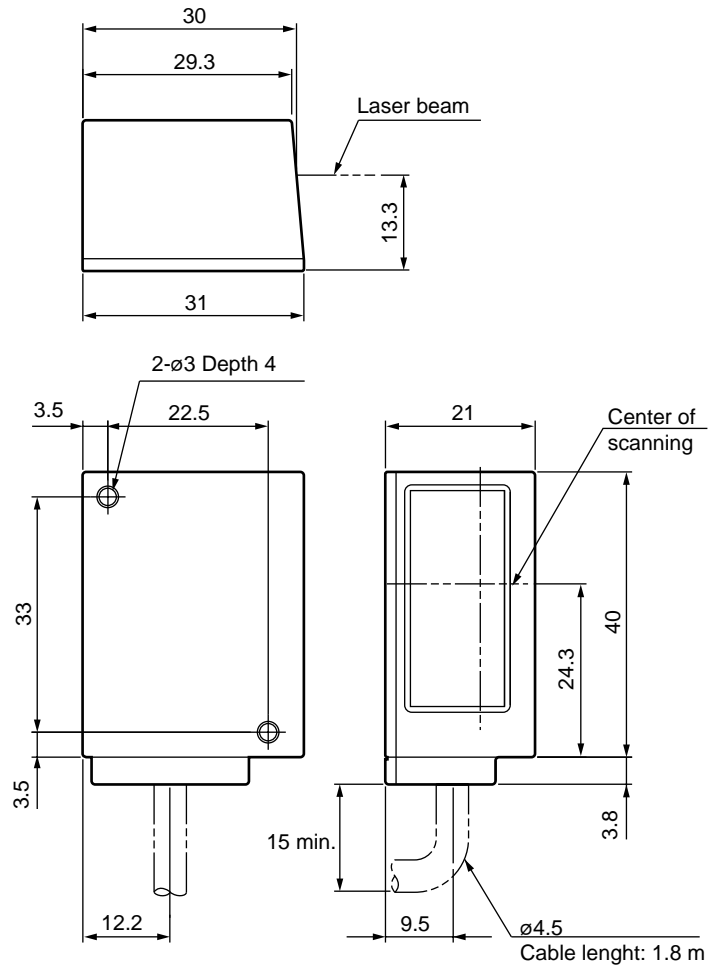

■ BL-650HA/651HA

* The laser beam application angle is $17^{\circ} \pm 3^{\circ}$ with reference to a line perpendicular to the rear surface of the unit.

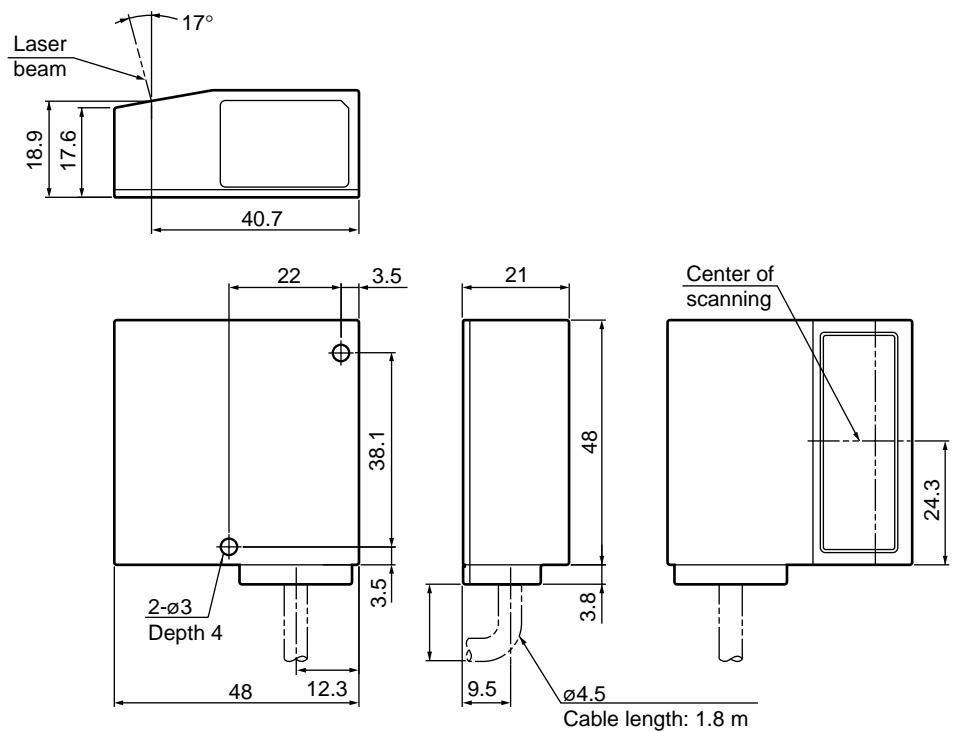

■ BL-600/601/600HA/601HA (Mounting bracket)

* Use M4 screws to mount the BL-600 unit.

• When bracket A is used

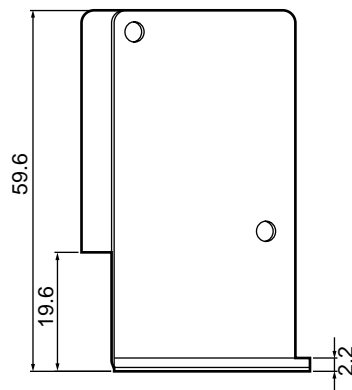
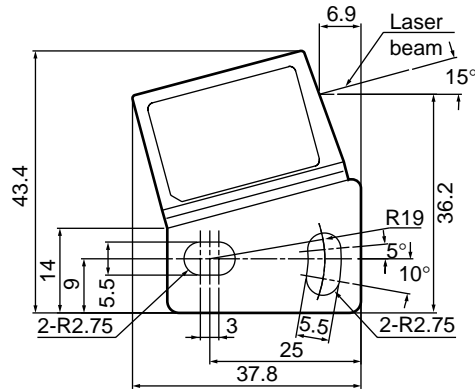

• When bracket B is used

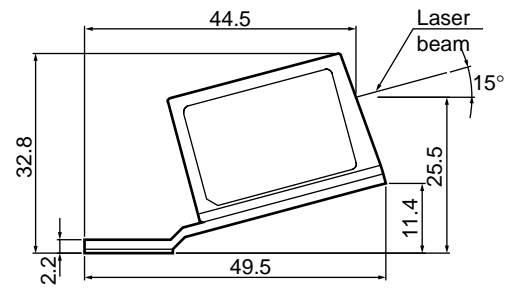
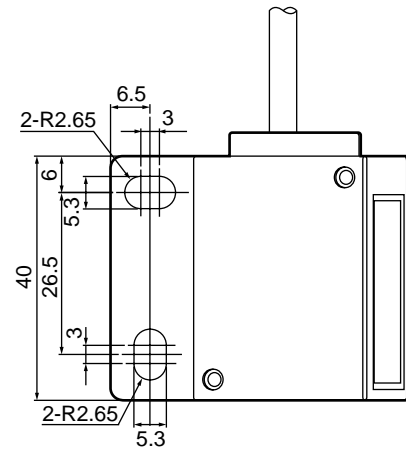

■ Mounting bracket for the BL-600/601/600HA/601HA

• When bracket A is used

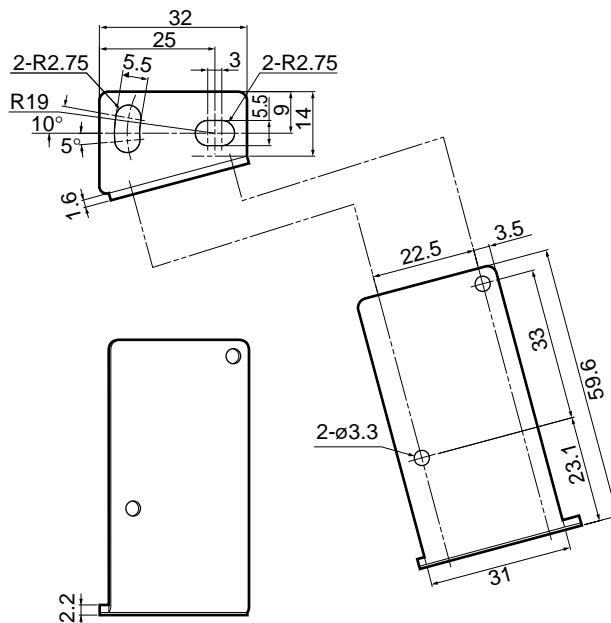

- When bracket B is used

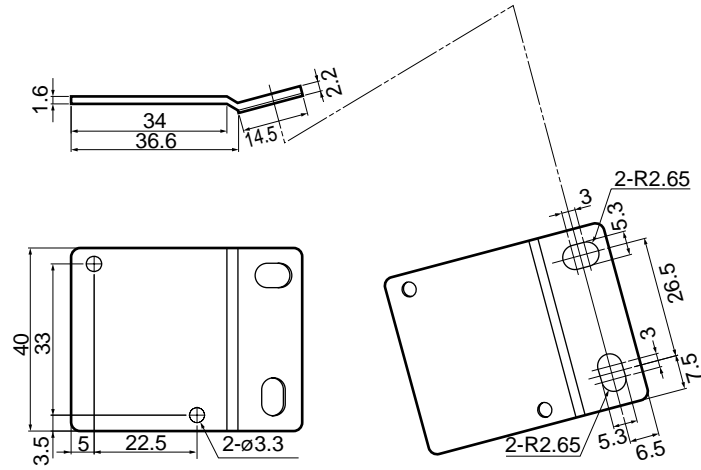

■ BL-/650HA/651HA (Mounting bracket)

- * Use M4 screws to mount the BL-600 unit.

- Vertical scanning

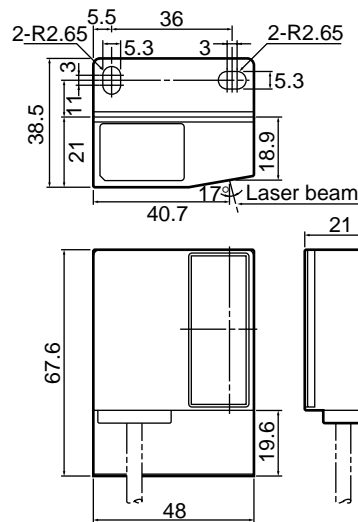

- Horizontal scanning

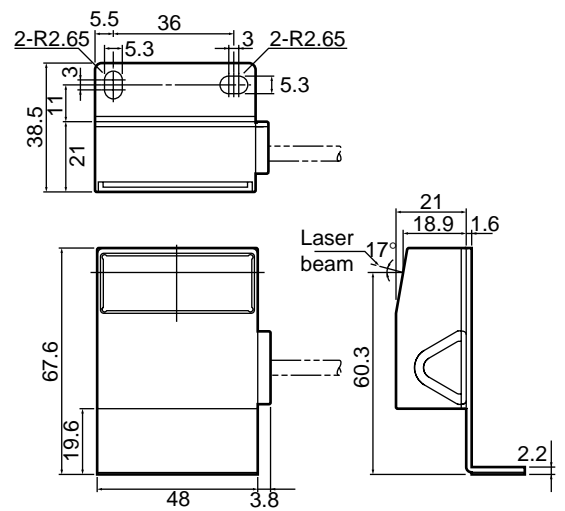

■ Mounting bracket for the BL-650HA/651HA

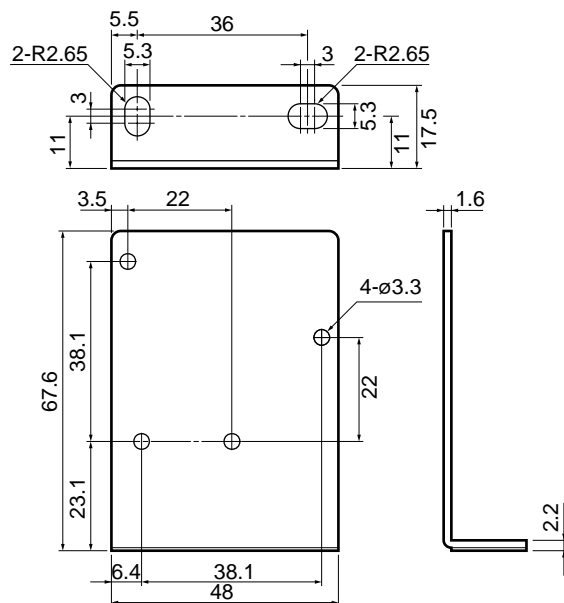

■ BL-U1*

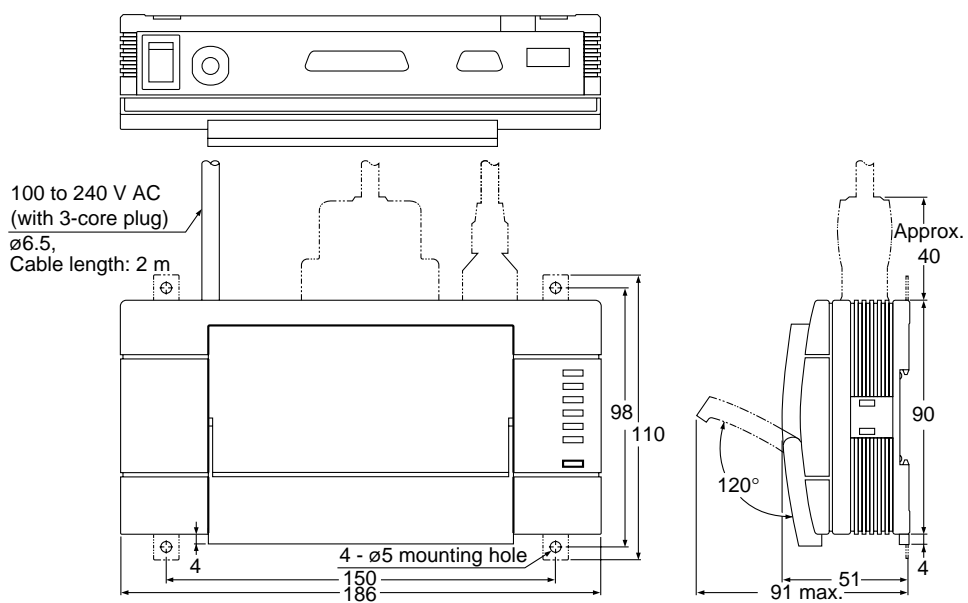

Note: BL-U1 is not available in Europe.

■ BL-U2

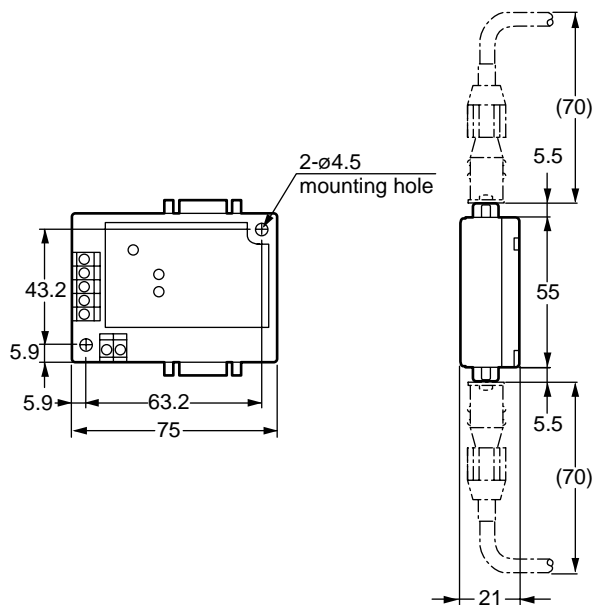

■ N-42

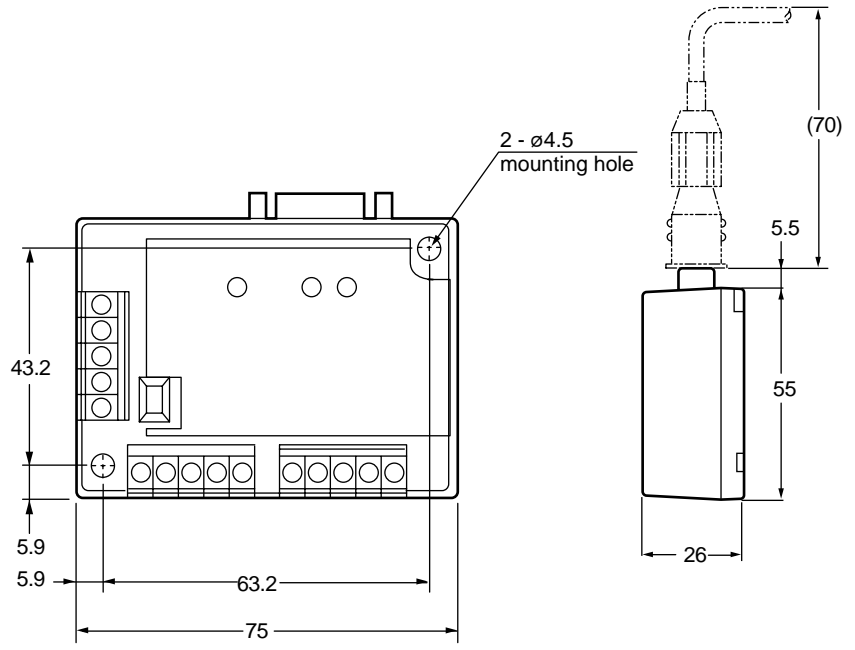

Appendix E Sample Program for the PLC Link

The sample program stores the read data in D105 (DM105) and subsequent DMs. You can change the program to suit your application. Before using the sample program, check that your system meets the following requirements.

■ BL-600 settings

- The scan method is “level signal trigger”.
- Use the “PLC trigger area”.
- The DM head address is “0000”.

■ Processing of data memory flag ... Sequential processing

- * This sample program uses the level signal trigger. However, it does not use the +05 trigger input response area to check if the BL-600 successfully recognized the +04 reading trigger area.

■ Program for the MELSEC-A Series

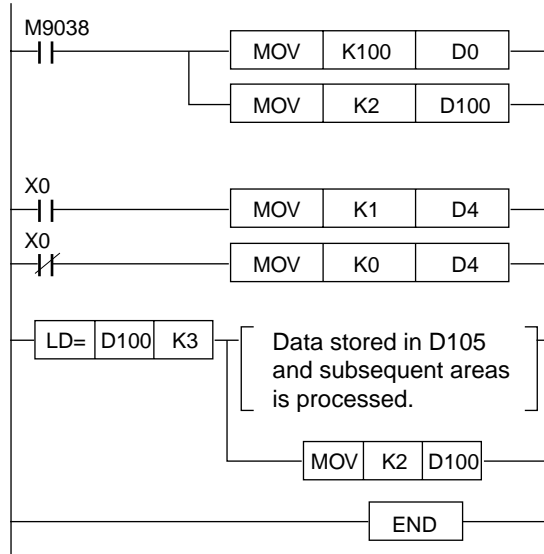

Specify the head address of the data memory area.
Enter "2" in the data memory flag.
(Use sequential processing to process the flag.)

Enter "X0" for the reading trigger input.

When D100 becomes "3", the specified processing is performed.
After processing is completed, enter "2" in D100.

■ Program for the SYSMAC-C

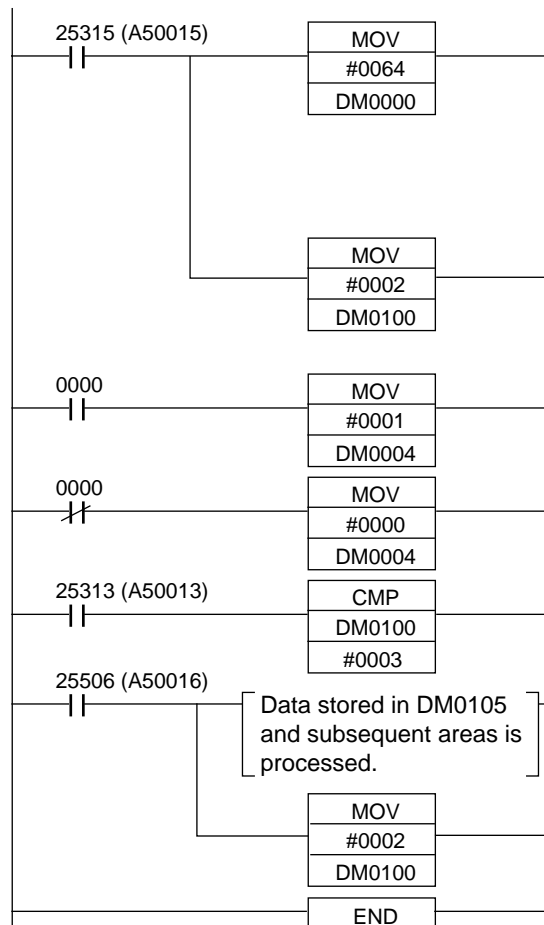

Specify the head address of the data memory area (DM100).
The BL-600 processes data as binary data. Specify each DM number in binary format.

Enter "2" in the data memory flag.
(Use sequential processing to process the flag.)

Enter "0000" for the reading trigger input.

When DM0100 becomes "3", the specified processing is performed.
After processing is completed, enter "2" in DM0100.

* The descriptions in parentheses are the cases for the CV Series.

■ Program for the KV Series

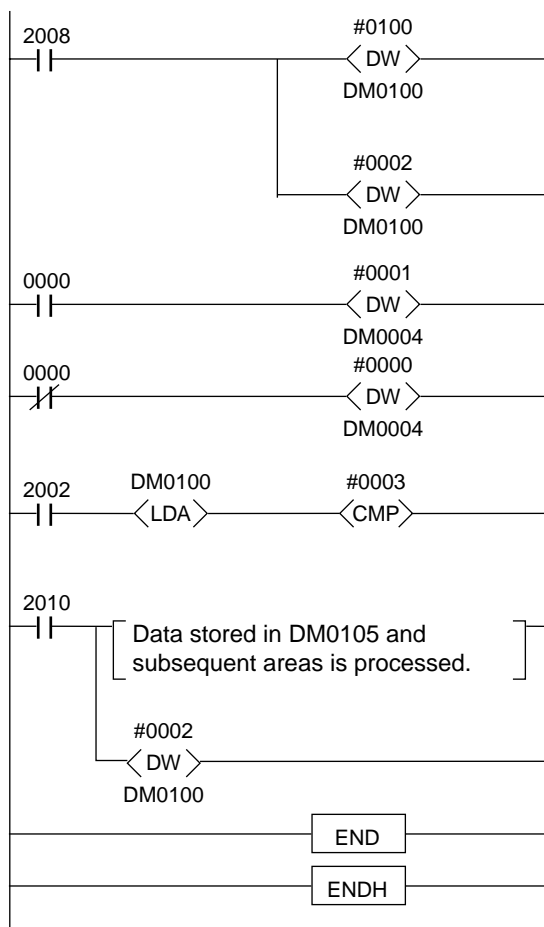

Specify the head address of the data memory area.

Enter "2" in the data memory flag. (Use sequential processing to process the flag.)

Enter "0000" for the reading trigger input.

When DM0100 becomes "3", the specified processing is performed. After processing is completed, enter "2" in DM0100.

Appendix F Troubleshooting

If a problem occurs during operation of the BL-600 Series, please check the following troubleshooting list first. If you cannot fix the problem, contact your nearest KEYENCE office or distributor (listed at the end of this manual).

Appendix F.1 Bar codes cannot be read

- **Check whether or not the laser is emitted.**

- If using the power supply unit BL-U1, BL-U2, N-42 or N-48, check the wiring of the power supply unit, the power switch (BL-U1 only), and the wiring of the trigger input terminal. ⇨ See pages 16 to 32.
- Check whether or not the laser off command (⇨ See page 116.) has been sent to the BL-600 Series. If so, send the resetting laser off command (UNLOCK) to enable laser emission.
If a laser off command has been executed, the bottom LED in the STABILITY indicator flashes.
- If a optional power supply unit is not used, confirm that the supplied power voltage and capacity (5 V DC±5%, 330 mA min.) is correct. Also, check the wiring of the power supply unit and the trigger input terminal.
⇨ See pages 33 to 35.

Note: Connecting the power supply in reverse may damage the product. If the BL-600 Series does not operate, contact your nearest KEYENCE office or distributor (listed at the end of this manual).

- **Check the bar code settings (type, No. of digits, etc.). Check the following parameters using the setup software.**

- Bar code type, No. of digits.
- Setting of the check digit inspection (enabled or disabled)
- Setting of the label orientation-specified reading

Note: When using CODE39 or Codabar, include the start/stop characters and check digit in the number of digits.

- ⇨ For CODE93, See page 164.
 - ⇨ For CODE128, See page 165.
-

- **Check the mounting distance and angle of the BL-600 Series.**

⇨ See page 74.

- **Check the bar code quiet zones (margins).**

A bar code requires the right and left margins to be at least 10 times wider than the narrow bar width.

If the bar code margins are too narrow, it may not be read. ⇨ See page 74.

- **Check the bar code label length.**

The bar code label length is the lateral length of a bar code including the right and left margins (quiet zones).

The readable bar code label length is limited depending on the reading distance. See "Appendix A.2 Reading range characteristics (Typical)" on page 148 to 150.

- **Check the printing quality of the bar code.**

A bar code with blurred sections, defects or stains may not be read correctly. Bar codes printed with dot matrix or ink jet printers are prone to such problems.

- **Check whether the transmitter (light source) and the receiver (optical pickup) are clean.**

If moisture, oil or dust adheres to the transmitter or the receiver, wipe the units using a soft cloth and a mild plastic cleaner.

- **Check the environmental conditions.**

⇒ See pages ii and 72 to 80 for details.

Appendix F.2 Reading rate check mode is not 100%

Check the previous item “Bar codes cannot be read”.

Note 1: The reading rate indicates the number of acceptable readings during 100 scans of a bar code. If a bar code has spots or voids, the reading rate is reduced.

Note 2: Even If the reading rate is 20%, two readings are acceptable during 10 scans. Therefore, if the decoding match count number is set to “2”, the bar code can be read. The read operation is not affected if the scan time for the bar code is set long enough.

Appendix F.3 The setting data cannot be sent/received using the setup software

Is the BL-600 set to “setting data send/receive waiting status”?

Press the TEST switch for 8 seconds to enter setting data send/receive waiting status. (The 1st, 3rd and 5th STABILITY LEDs from the top flash.) The BL-600 setup software [[Com port]] must be set as below:

- Baud rate: 9600 bit/s
 - Data length: 7 bits
 - Parity: Even
 - Stop bits: 1 bit
- **Does the RS-232C pin assignment of the BL-600 (BL-U1 or BL-U2) match that of the PC? Are the cables firmly attached?**
 - **Is power supplied to the BL-600, BL-U1 or BL-U2?**
 - **Is RS-232C used for the interface of the BL-U1 DIP switches?** ⇒ See page 9.

Appendix F.4 Cannot communicate successfully when using the PLC link

⇒ For details, see page 130.

Appendix G CODE93 Specifications

■ Setting of No. of Digits

- The start/stop character and check digit are not included in the number of digits.

■ Data Transmission

- The start/stop characters and check digit cannot be sent.
- Control codes are sent.

Note: Do not use CODE93 with control codes when using a multi-drop link. Communication errors may occur.

■ Registration of Preset Data

- When ! or ? is registered as preset data, it functions as the Preset “!” “?” Function, as described on page 45.
Since CODE93 can represent all ASCII codes as bar code data, ! or ? can also be represented as bar code data.
To register ! or ? as preset data, send \! or \? to differentiate them from the preset “!” “?” function.
To register \ as preset data, send \\.

Example

To register 123 \!?\?ABC as preset data, send the following command.

☞ See page 101.

WP68123 \\!\?ABC<CR>

- Control codes (data in 00h to 2Fh of the ASCII code table, such as <CR> and <STX>), the start/stop characters, and the check digit cannot be registered as preset data. (Data comparison is also impossible.)

Appendix H CODE128 Specifications

■ Setting No. of Digits

- The start/stop character and check digit are not included in the number of digits.
- FNC1 to 4 (Function codes), SHIFT, and CODE-A to -C should not be added to the number of digits.
- The number of digits setting range varies depending on the start character (CODE-A to -C).

CODE-A, B: 1 to 32

CODE-C: 1 to 64

One digit of CODE-A or CODE-B represents two digits of CODE-C.

■ Data Transmission

- The start/stop character and check digit cannot be sent.
- FNC1 to 4 (Function codes), SHIFT, and CODE-A to -C cannot be sent.
- Control codes are sent.

Note: Do not use CODE128 with control codes when you build a multidrop link. Communication errors may occur.

■ Registration of Preset Data

- The number of characters that can be registered as preset data is up to 32 digits for CODE-A or CODE-B, and up to 64 digits for CODE-C, as described above.
- When ! or ? is registered as preset data, it functions as the Preset “!” “?” Function, as described on page 18.
Since CODE128 can represent all ASCII codes as bar code data, ! or ? can also be represented as bar code data.
To register ! or ? as preset data, send \! or \? to differentiate it from the Preset “!” “?” function.

To register \ as preset data, send \\.

Example

To register 123 \!?\ABC as preset data, send the following command.

☞ See page 101.

```
WP68123 \\!\?ABC <CR>
```

- Control codes (data in 00h to 2Fh of the ASCII code table, such as <CR> and <STX>), start/stop character, check digit, FNC1 to 4 (function codes), SHIFT or CODE-A to -C cannot be registered as preset data. (Data comparison is also impossible.)

■ EAN-128 reading specifications

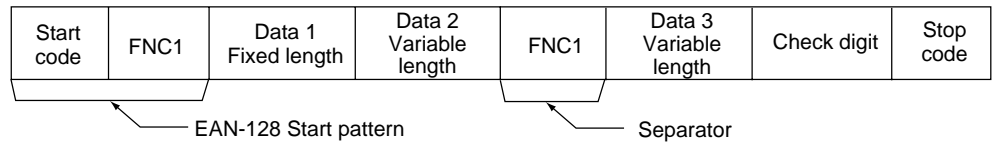

The BL-600 Series operates as follows if “EAN-128 support” is selected using the setup software. ⇨ See page 52.

- The header of the EAN-128 data is always the combination of a “Start code A to C” and “FNC1” (Start pattern). A reading error occurs when another item is used.
- “FNC1” (separator) is used at the end of each set of data that has a variable length to separate the data. “FNC1” is replaced with character [GS] (“1Dh” of ASCII code) for output.

Appendix I Checksum Calculation Method

You can add a checksum to transmitted data. (The checksum cannot be added to a command or a response to a command.)

Adding a checksum enables incorrect data translation to be detected in the RS-232C communication. If the checksum does not match when the PASS/RTRY or ACK/NAK protocol is used, modify the program so that the "Request to resend" (RTRY or <NAK>) command is sent to the BL-600. To set the checksum, use the "PROTOCOL SETUP" screen of the BL-600 setup software.

* The checksum cannot be added when the PLC link is used.

■ Checksum calculation range and the position to add checksum

The checksum calculation is performed with all characters except for the header and delimiter. The checksum is added immediately before the delimiter.

CC = Checksum (2 ASCII code characters)

- Data format

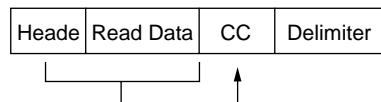

- When using the data addition function

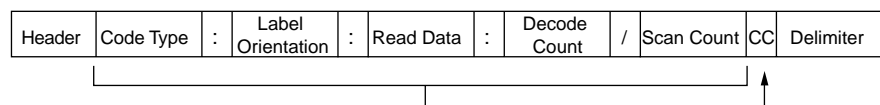

- Test mode

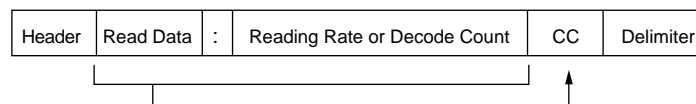

Checksum calculation method

Calculate the checksum (CC) using the read data of "ABC123" as an example. Convert each character into the ASCII code as shown below, and express the result as 8-bit binary numbers. Calculate the "Exclusive-OR" of the binary numbers of each bit.

Header	ABC123	CC	Delimiter
--------	--------	----	-----------

	ASCII code	Bit	
A	→ 41h → 0100	0001	
B	→ 42h → 0100	0010	
C	→ 43h → 0100	0011	
1	→ 31h → 0011	0001	
2	→ 32h → 0011	0010	
3	→ 33h → 0011	0011	⊕

	↓	↓	
	0111	0000	⇒ 70h

* Based on the "Exclusive OR" logic, when an odd number of "1"s are present, the calculation result is "1", and when an even number of "1"s are present, the calculation result is "0".

Convert the calculated hexadecimal number into an ASCII code in two digits. The result obtained is the checksum. Therefore, the checksum for the above example is "CC =70 (37h 30h)".

Example

Header	ERROR	CC	Delimiter	CC=58		
Header	KEYENCE	:	100 %	CC	Delimiter	CC=74

Reference 1: Exclusive OR calculation formula

Calculate the numbers of each bit, referring to the following formula:

- 0 ⊕ 0 = 0
- 0 ⊕ 1 = 1
- 1 ⊕ 0 = 1
- 1 ⊕ 1 = 0
- * ⊕ : Operator of Exclusive OR

Reference 2: Conversion from hexadecimal number into binary number
To convert ASCII codes into binary numbers, refer to the following table.

Hexadecimal number	0	1	2	3	4	5	6	7
Binary number	0000	0001	0010	0011	0100	0101	0110	0111
Hexadecimal number	8	9	A	B	C	D	E	F
Binary number	1000	1001	1010	1011	1100	1101	1110	1111

Appendix J ASCII Code Table

		High-order 4 bits								
Hexadecimal		0	1	2	3	4	5	6	7	
Binary		0000	0001	0010	0011	0100	0101	0110	0111	
Low-order 4 bits	0	0000	NUL	DLE	(SP)	0	@	P		p
	1	0001	SOH	DC1	!	1	A	Q	a	q
	2	0010	STX	DC2	"	2	B	R	b	r
	3	0011	ETX	DC3	#	3	C	S	c	s
	4	0100	EOT	DC4	\$	4	D	T	d	t
	5	0101	ENQ	NAK	%	5	E	U	e	u
	6	0110	ACK	SYN	&	6	F	V	f	v
	7	0111	BEL	ETB	'	7	G	W	g	w
	8	1000	BS	CAN	(8	H	X	h	x
	9	1001	HT	EM)	9	I	Y	i	y
	A	1010	LF	SUB	*	:	J	Z	j	z
	B	1011	HM	ESC	+	;	K	[k	{
	C	1100	CL	FS	,	<	L	\	l	
	D	1101	CR	GS	-	=	M]	m	}
	E	1110	SO	RS	.	>	N	^	n	~
	F	1111	SI	US	/	?	O	_	o	del

Appendix K Setup Parameter List

Fill in the specified data for each parameter.
Copy the list for daily operation.

■ Bar code setup

Setup parameter	Code 1	Code 2	Code 3	Code 4
Code type	()	()	()	()
Maximum number of digits	()	()	()	()
Minimum number of digits	()	()	()	()
Send start/stop character (CODE39, Coda bar)	<input type="checkbox"/> Don't send <input type="checkbox"/> Send	<input type="checkbox"/> Don't send <input type="checkbox"/> Send	<input type="checkbox"/> Don't send <input type="checkbox"/> Send	<input type="checkbox"/> Don't send <input type="checkbox"/> Send
Start/stop character type (Coda bar)	<input type="checkbox"/> Lowercase <input type="checkbox"/> Uppercase	<input type="checkbox"/> Lowercase <input type="checkbox"/> Uppercase	<input type="checkbox"/> Lowercase <input type="checkbox"/> Uppercase	<input type="checkbox"/> Lowercase <input type="checkbox"/> Uppercase
Test check digit (CODE39, Coda bar, ITF)	<input type="checkbox"/> Don't test <input type="checkbox"/> Test	<input type="checkbox"/> Don't test <input type="checkbox"/> Test	<input type="checkbox"/> Don't test <input type="checkbox"/> Test	<input type="checkbox"/> Don't test <input type="checkbox"/> Test
Check digit type (Coda bar)	()	()	()	()
Send check digit (CODE39, Coda bar, ITF)	<input type="checkbox"/> Don't send <input type="checkbox"/> Send	<input type="checkbox"/> Don't send <input type="checkbox"/> Send	<input type="checkbox"/> Don't send <input type="checkbox"/> Send	<input type="checkbox"/> Don't send <input type="checkbox"/> Send
Read EAN (More than one can be selected.)	<input type="checkbox"/> EAN 13-digit <input type="checkbox"/> EAN 8-digit <input type="checkbox"/> UPC-E	<input type="checkbox"/> EAN 13-digit <input type="checkbox"/> EAN 8-digit <input type="checkbox"/> UPC-E	<input type="checkbox"/> EAN 13-digit <input type="checkbox"/> EAN 8-digit <input type="checkbox"/> UPC-E	<input type="checkbox"/> EAN 13-digit <input type="checkbox"/> EAN 8-digit <input type="checkbox"/> UPC-E
	Number of output digits of UPC-A	<input type="checkbox"/> 13 digits <input type="checkbox"/> 12 digits	<input type="checkbox"/> 13 digits <input type="checkbox"/> 12 digits	<input type="checkbox"/> 13 digits <input type="checkbox"/> 12 digits
	Add "0" to UPC-E system code	<input type="checkbox"/> Don't add <input type="checkbox"/> Add	<input type="checkbox"/> Don't add <input type="checkbox"/> Add	<input type="checkbox"/> Don't add <input type="checkbox"/> Add
CODE 128	EAN-128 support	<input type="checkbox"/> Don't check <input type="checkbox"/> Check	<input type="checkbox"/> Don't check <input type="checkbox"/> Check	<input type="checkbox"/> Don't check <input type="checkbox"/> Check
Set specified-digit output function		<input type="checkbox"/> Don't set <input type="checkbox"/> Set	<input type="checkbox"/> Don't set <input type="checkbox"/> Set	<input type="checkbox"/> Don't set <input type="checkbox"/> Set
	Specified direction	<input type="checkbox"/> Forward <input type="checkbox"/> Backward	<input type="checkbox"/> Forward <input type="checkbox"/> Backward	<input type="checkbox"/> Forward <input type="checkbox"/> Backward
	Number of effective digits	()	()	()
	Start digit	()	()	()
Set label reading in the specified direction		<input type="checkbox"/> Don't set <input type="checkbox"/> Set	<input type="checkbox"/> Don't set <input type="checkbox"/> Set	<input type="checkbox"/> Don't set <input type="checkbox"/> Set
	Specified direction	<input type="checkbox"/> Forward <input type="checkbox"/> Reverse	<input type="checkbox"/> Forward <input type="checkbox"/> Reverse	<input type="checkbox"/> Forward <input type="checkbox"/> Reverse

■ Main setup

Read mode	<input type="checkbox"/> Single	Data send trigger	<input type="checkbox"/> After reading <input type="checkbox"/> After trigger OFF
	<input type="checkbox"/> Multi 1 <input type="checkbox"/> Multi 2	Double reading prevention time	()
	<input type="checkbox"/> Multi 3		
Decode match count	()		
Data addition function (more than one can be selected)	<input type="checkbox"/> Decode count <input type="checkbox"/> Scan count <small>(available only when decode count is added)</small>		
	<input type="checkbox"/> Label orientation <input type="checkbox"/> Code type <input type="checkbox"/> Adding a symbol identifier		
	<input type="checkbox"/> Preventive maintenance information (PMI)	PMI Preset value 1 (L1)	()
		PMI Preset value 2 (L2)	()
Reading error code	()		

■ Trigger Input Setup

Trigger input	Selection method	<input type="checkbox"/> Level signal trigger <input type="checkbox"/> One-shot signal trigger	
	One-shot signal trigger time	()	
	Input time	<input type="checkbox"/> 2 ms	<input type="checkbox"/> 10 ms
	Input polarity	<input type="checkbox"/> N.O.	<input type="checkbox"/> N.C.
	Trigger input operation at power-on	<input type="checkbox"/> Disable	<input type="checkbox"/> Enable
	Trigger the input status at power-on	<input type="checkbox"/> Don't start <input type="checkbox"/> Start	<input type="checkbox"/> Reading rate <input type="checkbox"/> Tact measurement measurement
	Start test mode at power ON	<input type="checkbox"/> Don't start <input type="checkbox"/> Start	<input type="checkbox"/> Reading rate <input type="checkbox"/> Tact measurement measurement
Command	Trigger ON command	()	
	Trigger OFF command	()	

■ Comm Settings-1

Baud rate	()				
Data length	<input type="checkbox"/> 7 bits <input type="checkbox"/> 8 bits	<input type="checkbox"/> Stop bits	<input type="checkbox"/> 1 bit <input type="checkbox"/> 2 bits	<input type="checkbox"/> Parity	<input type="checkbox"/> None <input type="checkbox"/> Even <input type="checkbox"/> Odd
RTS/CTS protocol	<input type="checkbox"/> Don't use <input type="checkbox"/> Use				
Multi-drop link	<input type="checkbox"/> Don't use				
	<input type="checkbox"/> Use	<input type="checkbox"/> ID No.	()		

■ Communication parameters 2

PLC link	<input type="checkbox"/> Don't use	Protocol	<input type="checkbox"/> Non-procedure <input type="checkbox"/> PASS/RTRY <input type="checkbox"/> ACK/NAK
		Header	<input type="checkbox"/> None <input type="checkbox"/> STX <input type="checkbox"/> ESC <input type="checkbox"/> Specify ()
		Delimiter	<input type="checkbox"/> None <input type="checkbox"/> CR+LF <input type="checkbox"/> ETX <input type="checkbox"/> Specify ()
		Checksum	<input type="checkbox"/> Don't add <input type="checkbox"/> Add
		Transmission delay time	()
	<input type="checkbox"/> Use	PLC type	<input type="checkbox"/> SYSMAC-C <input type="checkbox"/> MELSEC-A <input type="checkbox"/> KV
		PLC trigger area	<input type="checkbox"/> Don't use <input type="checkbox"/> Use
		DM head address	() 00
		PLC station/Unit No.	()
		File register	<input type="checkbox"/> Don't use <input type="checkbox"/> Use
		File register block No.	()

■ Communication character

Delimiter character	()
Semi-delimiter	()

■ Utilities

Display STABILITY LEDs	<input type="checkbox"/> Don't display <input type="checkbox"/> Display
OK/NG output ON time	()
Preset data	()
Scaling factor for the quiet zone	()
Reading a reversed bar code	<input type="checkbox"/> Don't display <input type="checkbox"/> Display
Outputting the test mode result	<input type="checkbox"/> Don't display <input type="checkbox"/> Display
Changing the decoding match count	()

Appendix L Default Setting List

■ Bar code setup

Parameter	Code 1	Code 2	Code 3	Code 4
Code type	CODE39	Coda bar	UPC/EAN	CODE128
Maximum number of digits	32	32	–	32
Minimum number of digits	03	03	–	01
Send start/stop character	Don't send	Send	–	–
Start/stop character type	–	Lowercase	–	–
Test check digit	Don't test	Don't test	–	–
Read JAN (More than one can be selected.)	–	–	All EAN 13-digit, EAN 8-digit and UPC-E are readable.	–
Number of output digits of UPC-A	–	–	13 digits	–
Add "0" to UPC-E system code	–	–	Don't add	Don't add
Set specified-digit output function	Don't set	Don't set	Don't set	Don't set
Set label reading in the specified direction	Don't set	Don't set	Don't set	Don't set

■ Main setup

Read mode	Single
Data send trigger	After reading
Decode match count	2
Data addition function	None
Reading error code	ERROR

■ Trigger input setup

Selection method	Level signal trigger
Input time	2 ms
Input polarity	Normal Open
Trigger input operation at power-on	Disable
Start test mode at trigger input ON	Don't start
Start test mode at power ON	Don't start
Trigger ON command	LON
Trigger OFF command	LOFF

■ Comm Settings-1

Baud rate	9600 bit/s
Data length	7 bits
Parity	Even
Stop bits	1 bit
RTS/CTS protocol	Don't use
Multi-drop link	Don't use

■ Comm Settings-2

PLC link	Don't use
Protocol	Non-procedure
Header	None
Delimiter	CR
Checksum	Don't add
Transmission delay time	0 ms

■ Communication character

Delimiter character	: [3A]
Semi-delimiter	, [2C]

■ Utilities

OK/NG output ON time	500 ms
STABILITY LEDs	Don't display
Preset data	Don't set
Scaling factor for the quiet zone	x7
Reading a reversed bar code	Don't read
Outputting the test mode result	Display
Changing the decoding match count	0

Index

Index

The index lists the terms used in this manual in alphabetical order.

- A**
- ACK/NAK protocol 112
 - Additional data area 140
 - After read 88
 - Angular characteristics 151
 - ASCII code table 169
 - At trigger input 88
- B**
- BL-U1 7, 10, 16
 - BL-U2 7, 11, 25, 26
- C**
- Checksum 46, 167, 168
 - Code length 49
 - Code setup (screen) 49
 - Code type add function 103
 - Command communication 110
 - Command for trigger OFF 44, 115
 - Command for trigger ON 44, 115
 - Comm port 55
 - Comm Settings-1 (screen) 45
 - Comm Settings-2 (screen) 46
 - Communication status indicator LEDs 10, 11
 - Communication time 87, 143
 - Connector 10, 33
- D**
- Data memory area
(No. of digits, data) 141
 - Data memory head address 135, 137
 - Decode match count add function 102
 - Decoding match count 43
 - Delimiter 113
 - DIN-rail mounting claw 10, 82
 - DIP switch 10, 17
 - Direct control command 114 to 117
- E**
- EAN-128 166
 - Exclusive OR 168
 - Extraneous light 72
- F**
- File register 131
 - Files (screen) 59
 - Forward orientation 93, 103
- H**
- Head address 135
 - Header 113
- I**
- I/O terminal block 10, 18
 - Input time 44, 86
 - Intermediate delimiter 47, 90
- L**
- Label orientation mode 93
 - LASER ON LED 4, 8
 - Laser warning label 3, 6
 - Level signal trigger 86
- M**
- Main (screen) 42
 - Max. code length output function 107
 - Memory data flag area 139
 - Monitor 62
 - Mounting angle 74
 - Mounting bracket 10
 - Mounting distance 74
 - Multi-drop controller 14
 - Multi-drop link 14
 - Multi label read mode 1 89
 - Multi label read mode 2 90
 - Multi label read mode 3 91
- N**
- N-400 7, 14
 - N-42 7, 11, 25, 26
 - N-48 7, 14
 - No handshaking 111
- O**
- OK/NG LED 8, 10
 - OK/NG output 18, 27, 34
 - One-shot signal trigger 87
 - Online test mode 99
- P**
- Partition mark 102
 - PASS/RTRY protocol 111
 - Pitch 151
 - PLC link 130
 - PLC link error 142
 - PMI
(Preventive Maintenance Information) 104 to 106
 - POWER LED 10
 - Power-on trigger 44
 - Power supply terminals 11, 25
 - Preset function 101
- Q**
- Quiet zone 53, 54

R

Raster scan	147
READER port	10, 11, 16, 26
Read error code	43, 113
Reading range characteristics	148 to 150
Reading rate check mode	94
Reading trigger area	135, 137
Real-time processing	139
Receiving buffer	114
Repeat-reading time	89
Reverse orientation	93, 103
RS-232C port	10, 11, 20, 28
RS-422A terminal	23, 31
RTS/CTS protocol	45, 112

S

Scan count add function	102
Scanning width	67, 117
Send delay time	47
Sending/Receiving settings	54
Sequence processing	140
Serial communication	110
Setting commands	118 to 128
Setting data send/receive waiting status	54
Single label read mode	88
Skew	151
Specular reflection	72, 74, 151
STABILITY LED	8, 95, 98, 99, 100
State	44
Symbology identifier add function	104

T

Tact check mode	97
Terminator switch	11, 31
TEST switch	8
Tilt	151
TIMING LED	8, 10
Transmission buffer	112
Transmitter/receiver	8
Trigger input	19
Trigger input terminal	11, 26
Twisted pair cable	23, 24, 31, 32

U

Using “?” and “!” in the preset data	101
Utilities (screen)	53

WARRANTIES AND DISCLAIMERS:

(1) KEYENCE warrants the Products to be free of defects in materials and workmanship for a period of one (1) year from the date of shipment. If any models or samples were shown to Buyer, such models or samples were used merely to illustrate the general type and quality of the Products and not to represent that the Products would necessarily conform to said models or samples. Any Products found to be defective must be shipped to KEYENCE with all shipping costs paid by Buyer or offered to KEYENCE for inspection and examination. Upon examination by KEYENCE, KEYENCE, at its sole option, will refund the purchase price of, or repair or replace at no charge any Products found to be defective. This warranty does not apply to any defects resulting from any action of Buyer, including but not limited to improper installation, improper interfacing, improper repair, unauthorized modification, misapplication and mishandling, such as exposure to excessive current, heat, coldness, moisture, vibration or outdoors air. Components which wear are not warranted.

(2) KEYENCE is pleased to offer suggestions on the use of its various Products. They are only suggestions, and it is Buyer's responsibility to ascertain the fitness of the Products for Buyer's intended use. KEYENCE will not be responsible for any damages that may result from the use of the Products.

(3) The Products and any samples ("Products/Samples") supplied to Buyer are not to be used internally in humans, for human transportation, as safety devices or fail-safe systems, unless their written specifications state otherwise. Should any Products/Samples be used in such a manner or misused in any way, KEYENCE assumes no responsibility, and additionally Buyer will indemnify KEYENCE and hold KEYENCE harmless from any liability or damage whatsoever arising out of any misuse of the Products/Samples.

(4) OTHER THAN AS STATED HEREIN, THE PRODUCTS/SAMPLES ARE PROVIDED WITH NO OTHER WARRANTIES WHATSOEVER. ALL EXPRESS, IMPLIED, AND STATUTORY WARRANTIES, INCLUDING, WITHOUT LIMITATION, THE WARRANTIES OF MERCHANTABILITY, FITNESS FOR A PARTICULAR PURPOSE, AND NON-INFRINGEMENT OF PROPRIETARY RIGHTS, ARE EXPRESSLY DISCLAIMED. IN NO EVENT SHALL KEYENCE AND ITS AFFILIATED ENTITIES BE LIABLE TO ANY PERSON OR ENTITY FOR ANY DIRECT, INDIRECT, INCIDENTAL, PUNITIVE, SPECIAL OR CONSEQUENTIAL DAMAGES (INCLUDING, WITHOUT LIMITATION, ANY DAMAGES RESULTING FROM LOSS OF USE, BUSINESS INTERRUPTION, LOSS OF INFORMATION, LOSS OR INACCURACY OF DATA, LOSS OF PROFITS, LOSS OF SAVINGS, THE COST OF PROCUREMENT OF SUBSTITUTED GOODS, SERVICES OR TECHNOLOGIES, OR FOR ANY MATTER ARISING OUT OF OR IN CONNECTION WITH THE USE OR INABILITY TO USE THE PRODUCTS, EVEN IF KEYENCE OR ONE OF ITS AFFILIATED ENTITIES WAS ADVISED OF A POSSIBLE THIRD PARTY'S CLAIM FOR DAMAGES OR ANY OTHER CLAIM AGAINST BUYER. In some jurisdictions, some of the foregoing warranty disclaimers or damage limitations may not apply.

BUYER'S TRANSFER OBLIGATIONS: If the Products/Samples purchased by Buyer are to be resold or delivered to a third party, Buyer must provide such third party with a copy of this document, all specifications, manuals, catalogs, leaflets and written information provided to Buyer pertaining to the Products/Samples.

Specifications are subject to change without notice.

KEYENCE

KEYENCE CORPORATION

1-3-14, Higashi-Nakajima, Higashi-Yodogawa-ku,
Osaka, 533-8555, Japan
PHONE: 81-6-6379-2211 FAX: 81-6-6379-2131

AFFILIATED COMPANIES

KEYENCE CORPORATION OF AMERICA
PHONE: 201-930-0100 FAX: 201-930-0099

KEYENCE DEUTSCHLAND GmbH
PHONE: 06102-36 89-0 FAX: 06102-36 89-100

KEYENCE (UK) LIMITED
PHONE: 01908-696900 FAX: 01908-696777

KEYENCE FRANCE S.A.
PHONE: 01 47 92 76 76 FAX: 01 47 92 76 77

KEYENCE SINGAPORE PTE LTD
PHONE: 392-1011 FAX: 392-5055

KEYENCE (MALAYSIA) SDN BHD
PHONE: 03-252-2211 FAX: 03-252-2131

KEYENCE (THAILAND) CO., LTD
PHONE: 02-369-2777 FAX: 02-369-2775

KEYENCE TAIWAN CO., LTD
PHONE: 02-2627-3100 FAX: 02-2798-8925

KEYENCE KOREA CORPORATION
PHONE: 02-563-1270 FAX: 02-563-1271