

Quick Reference Guide

P/N 060207-002

**JANUS[®] 900 MHz
Radio Frequency**

ntermec

A **UNOVA** Company

Intermec® Corporation
6001 36th Avenue West
P.O. Box 4280
Everett, WA 98203-9280

U.S. technical and service support: 1-800-755-5505
U.S. media supplies ordering information: 1-800-227-9947

Canadian technical and service support: 1-800-688-7043
Canadian media supplies ordering information: 1-800-268-6936

Outside U.S. and Canada: Contact your local Intermec service supplier.

The information contained herein is proprietary and is provided solely for the purpose of allowing customers to operate and/or service Intermec manufactured equipment and is not to be released, reproduced, or used for any other purpose without written permission of Intermec.

Information and specifications in this manual are subject to change without notice.

© 1996 by Intermec Corporation
All Rights Reserved

The word Intermec, the Intermec logo, JANUS, IRL, TRAKKER, Antares, Duratherm, Precision Print, PrintSet, Virtual Wedge, and CrossBar are either trademarks or registered trademarks of Intermec Corporation.

Throughout this manual, trademarked names may be used. Rather than put a trademark (™ or ®) symbol in every occurrence of a trademarked name, we state that we are using the names only in an editorial fashion, and to the benefit of the trademark owner, with no intention of infringement.

Manual Change Record

This page records the changes to this manual. The manual was originally released at -001.

Version	Date	Description of Change
002	7/95	JANUS 2050 information added.

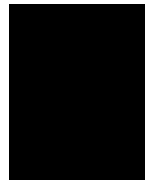

Contents

Overview of an RF System	7
Setting Up RF Communications	8
Attaching the Antenna	8
Configuring the RF Parameters	10
Unloading and Loading the RF Protocol Handler	12
Using RF Communications	13
Understanding the RF Status Icons and LEDs	13
Managing Your J2010 and JR2020 Battery Power	14
Troubleshooting Your J2010 and Your JR2020	15
Troubleshooting Your J2050	16
Configuring Your JANUS RF Device	17
Using RF Communications	17
Using the Interactive Configuration Application	18
Scanning Bar Code Labels	19
RF Configuration Parameters	19
Acknowledgment Delay	19
Broadcast Receipt	20
Channel Allow	21
Channel Select	22
Device Address	23
Duty Cycle Percent	26
Duty Cycle Period	27
Loopback	29
Network ID	29
Repeat Count	31
Retry Limit	32
RF Protocol	33
RFNC Address	34

This guide describes how to use radio frequency communications on the JANUS RF devices (J2010 with an RF back and JR2020 handheld data collection computers and J2050 vehicle-mount computer). It also tells you how to attach the antenna and configure the JANUS RF devices. For more help about any other features, refer to your JANUS user's manual.

Overview of an RF System

A radio frequency (RF) data collection system establishes a two-way radio link between a JANUS RF device and a central network controller. The data from the JANUS RF device is sent in real time through the RF system to the network controller and then on to the host computer. The RF link is completely transparent to the user. The following illustration shows one example of an RF data collection system.

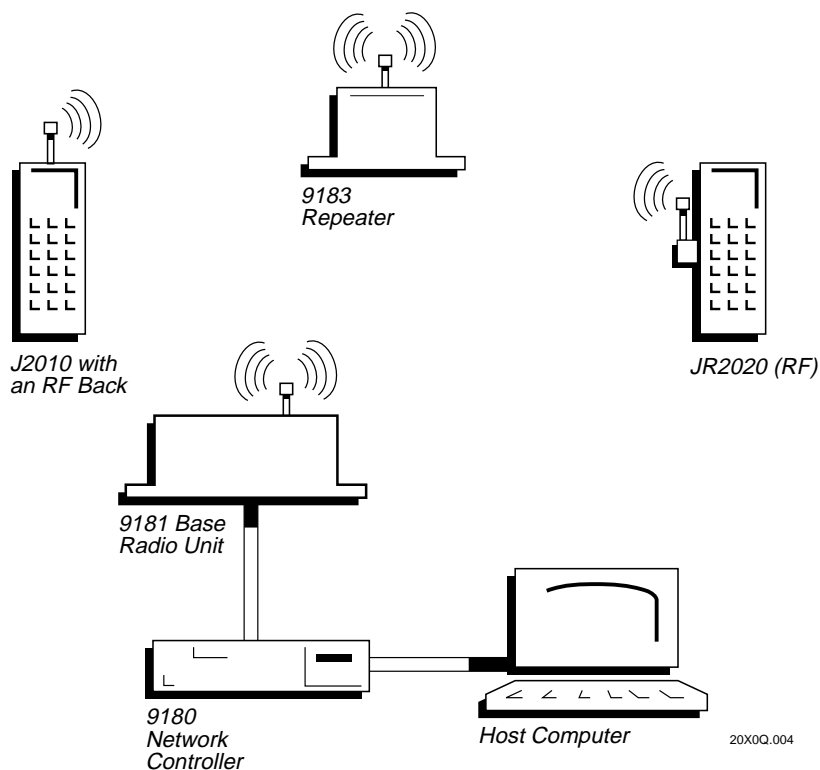

With your JANUS RF device you can move anywhere within range of a base radio unit (BRU) or a radio repeater and transmit data to and from a network controller that is connected to a host computer. If your controller has a 900 MHz RF ISA card installed, you can transmit directly to it. For help in learning about RF systems, refer to your controller user's manual.

Setting Up RF Communications

Before you can use RF communications on the JANUS RF device, you need to do the following:

- Attach the antenna to the J2010 with an RF back, JR2020, or J2050.
- Configure the RF parameters.
- Make sure that the RF protocol handler is loaded.

Attaching the Antenna





Caution

The antenna must be attached before turning on the JANUS RF device. The internal radio could be damaged if the antenna is not attached.

Conseil

Si l'antenna n'est pas attachée avant que l'appareil RF de JANUS soit mise sous tension, la radio interne peut être endommagée.

Note: Do not interchange antennas between any of the JANUS RF devices. Each antenna is built specifically for the radio that is installed in the device.

1. Make sure the JANUS RF device is switched off. If the JANUS RF device is on, switch it off by pressing .
2. Screw the antenna into the connector of the JANUS RF device. Refer to the following illustrations.
3. Switch on the JANUS RF device by pressing .



Attaching the J2010 Antenna

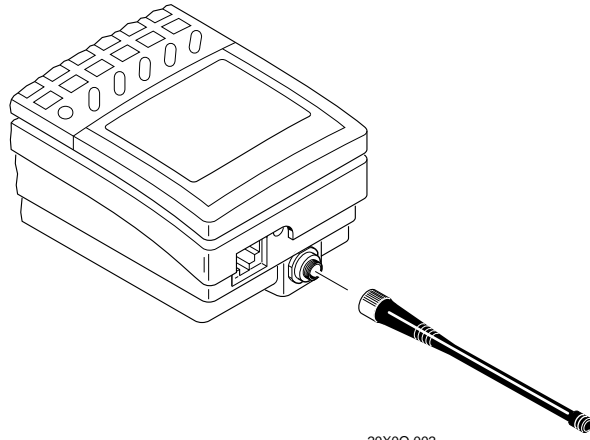

20X0Q.002

Attaching the J2050 Antenna

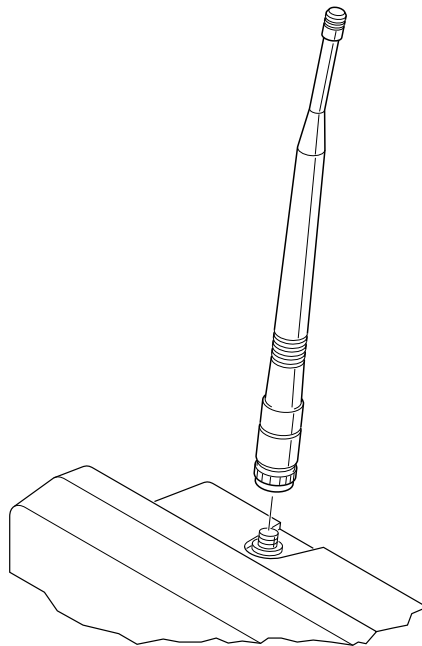

2050U.009

Attaching the JR2020 Antenna

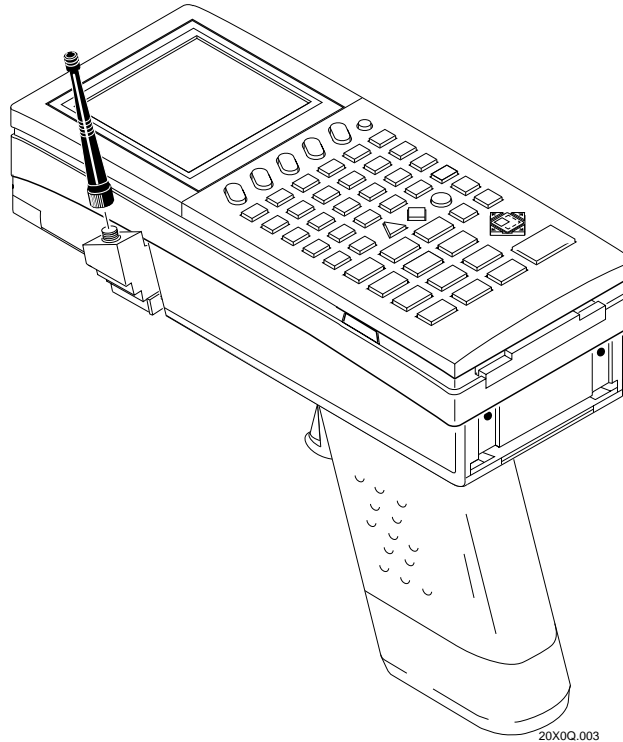

Configuring the RF Parameters

The RF configuration parameters define radio communications between the JANUS RF device and the Intermec RF data collection system.

Note: *The software version of your 9180 network controller can affect which RF configuration parameters you set. Refer to the next section, “About Your Controller Software Version.”*

RF Configuration Parameter	Default Setting
Acknowledgment Delay	100 milliseconds
Broadcast Receipt	Enabled
Channel Allow	All channels are excluded from the search pattern
Channel Select	924 MHz
Device Address	0 (turned off)

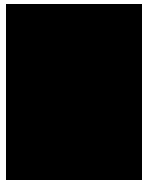

RF Configuration

Parameter	Default Setting
Duty Cycle Percent (reader)	30%
Duty Cycle Percent (J2050)	100%
Duty Cycle Period	1 second
Loopback	Disabled
Network ID	Channel search disabled
Repeat Count	0 repeaters
Retry Limit	0 (optimized setting)
RF Protocol	Enabled
RFNC Address	RFNC 0

To configure the JANUS RF device, follow the instructions in “Configuring a JANUS RF Device” later in this guide.

About Your Controller Software Version

The software version that is running on your 9180 Network Controller determines the RF configuration parameters you need to set on your JANUS RF devices. If you have a 9180 controller running software version 1.3 or earlier, you do not have some features that the 9180 controller with software version 2.0 and the 9185 Network Controller have. These enhanced features include time broadcast, channel search capabilities, network management, and support for multiple BRUs.

If the 9180 controller is running software version 1.3 or earlier

Parameter on JANUS RF device	Must match
Device Address	The address used by the network controller to identify each JANUS RF device.
Channel Select	The channel set for the BRU.
Network ID	0
RFNC Address	A value that is twice the setting on the network controller. For example, if the network controller address is 2, you would set the RFNC address on the JANUS RF device to 4.
Repeat Count	The setting on the network controller.

If the 9180 controller is running software version 2.0 or you have a 9185 controller

Parameter on JANUS RF device	Must match
Device Address	The address used by the network controller to identify each JANUS RF device.
Channel Select	The channel set for the BRU that is most frequently used by the JANUS RF device.
Network ID	The value entered for the network ID on the network controller.

Note: The Channel Allow parameter must be set if you are going to be communicating on more than one frequency by using the channel search feature.

For help in learning about the network controller, base radio unit, and radio repeater, refer to your user's manual.

Unloading and Loading the RF Protocol Handler

The protocol handler for RF communications automatically loads when you boot a JANUS RF device.

If you do not need the RF protocol handler, you can unload it. For help in learning about protocol handlers, refer to your JANUS user's manual.

To unload the RF protocol handler

- From the JANUS RF device DOS prompt, type:

```
unload rfph 4
```

Note: The "4" in the command line indicates you are unloading the protocol handler for COM port 4 (RF interface).

If you have unloaded the RF protocol handler, and want to use RF communications without rebooting your JANUS RF device, you can load it again.

To load the protocol handler

- From the JANUS RF device DOS prompt, type:

```
rfph 4
```



Using RF Communications

For RF communications, use the Communications Manager, IRL Desktop, or an application created using the software libraries provided in the Programmer's Software Kit Language Libraries. For help in learning about the language libraries, refer to your JANUS PSK reference manual.

Note: The Interlnk/Intersvr utilities do not work with RF communications.

When you use a communications program, the RF communications port is designated as COM4. Since COM4 is not a standard PC communications port, you cannot access it with commercial communications packages.

You can switch between RF communications and serial communications (by designating whether you are talking to COM1 or COM4. If you are switching between COM1 and COM4, you need to have protocol handlers loaded for both ports.

Once your RF system is configured for RF communications, you can begin collecting and transmitting data using your JANUS RF device to and from a network controller. When you transmit data using the JANUS RF device, the information is first sent to its radio buffer. The data is then sent on to the network controller. Even if the RF network goes down, you can continue to collect data until the radio buffer is full. When the buffer is full, the application returns a communication timeout status. The actual status response depends on what language you used to develop the application. When your RF network comes back up, the data in the radio buffer is transmitted to the network controller and you can once again transmit data.



Caution

Do not operate two RF devices within 2 feet (0.6 meters) of each other when using RF communications. Doing so may damage the radio receivers.

Conseil

Assurez-vous de ne pas utiliser deux devices RF de carte à moins de 2 pieds (0,6 mètres) l'un de l'autre lorsque vous effectuez des communications en radiofréquence. Sinon, les récepteurs radio pourront être endommagés.

Understanding the RF Status Icons and LEDs

RF status icons on the reader display correspond to LEDs on the J2050 case. These RF icons and LEDs are used to manage RF communications:

- * **Connected** This icon contains an asterisk. The icon or LED flashes when the RF interface is either actively channel searching or trying to reestablish communications with the network controller. When this icon or LED is solid, the RF interface is connected to a network controller. The RF interface in the JANUS RF device handles RF communications.

If this icon or LED is off, RF communications are not possible. The JANUS RF device may not be set up correctly for RF communications or there may be another problem such as the battery being low. If RF communications appear to be locked up, see one of the troubleshooting sections later in this guide for more help.

- **Data** This icon contains a square. The icon or LED turns on when data is buffered in the RF interface. The data is either being transmitted to the network controller or received data has not been accepted by the JANUS RF device application. Up to five messages can be buffered in the RF interface.

If there are messages in the RF interface when RF communications are turned off, the data icon or LED remains on.

***Note:** Do not turn off the JANUS RF device when the data icon or LED is lit. If you turn off the JANUS RF device, the RF interface saves the data and attempts to transmit the data again when the JANUS RF device is powered on. This could cause problems if the JANUS RF device is not powered back on for some time. The data could then be meaningless and/or disrupt the host application.*

-  **Battery** (JANUS 2010 and 2020 readers only.) This icon turns on and stays on when the NiCad battery pack has approximately 15 to 45 minutes of power left. Immediately replace or recharge the battery pack because you will soon lose RF communications. For help, see your JANUS RF documentation.

If you continue to operate the reader without replacing or recharging the battery pack, the battery pack charge becomes very low. The Battery icon stays on, the reader chirps every 5 seconds, and then turns off after 1 minute. The laser scanner and RF communications are turned off 15 seconds after the first low battery chirp.

You cannot turn the reader back on until you replace the battery pack. The Battery icon disappears when you replace or recharge the NiCad battery pack.

Managing Your J2010 and JR2020 Battery Power

The JANUS reader's RF interface has built-in power management to maximize the life of the battery. The RF interface is the hardware and software built into the reader to handle RF communications. For more ideas on how to conserve battery life, see your JANUS user's manual.

To conserve battery life, the RF interface turns off. No RF communications are possible in these situations:

- Reader is off.

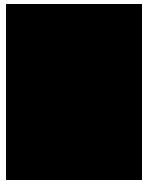

- RF protocol is disabled.
- RF protocol handler is not loaded.
- NiCad battery pack charge is very low.

To avoid losing RF communications, when the battery icon on the reader display turns on and off, you need to replace or recharge the NiCad battery pack immediately. Approximately 15 minutes later, when the reader beeps, RF communications are turned off.

When you remove the battery pack, replace it immediately with a spare charged battery pack. If you leave the reader without a charged battery pack, even for a short time, you will prematurely discharge the lithium backup battery.

You can extend the life of the battery pack by setting the Duty Cycle Percent and Duty Cycle Period parameters on the reader. Duty cycle causes the RF interface to alternate between receiving and standby. When the RF interface is in standby, it uses less battery power, but does not receive messages from the controller. The RF interface comes out of standby at the end of the duty cycle period, or when the reader sends a message through COM4.

Note: If the reader is not going to be used for 1 week or longer, it is important that you put the reader in Storage mode and remove the NiCad battery pack. If you do not remove the NiCad battery pack, the reader will slowly drain the battery pack. For help, see your JANUS user's manual.

Troubleshooting Your J2010 and Your JR2020

If you are having problems with RF communications, review the following list of problems and their possible solutions.

Note: The readers and the J2050 have slightly different procedures. If you have a J2050, refer to the next section, "Troubleshooting the J2050."

You can also use network management commands (\$+NM..) to troubleshoot the RF interface. For help on using network management commands for troubleshooting, refer to your controller user's manual.

Problem

The RF option is not listed in the Com menu of IC.EXE.





You load the RF protocol handler and do not receive the message Intermec RF Protocol Handler.

Solution

The reader is not recognizing the RF interface. Contact your Intermec service representative.

The RF interface is not responding. Contact your Intermec service representative.

Troubleshooting Your J2010 and Your JR2020 (continued)

Problem	Solution
The Battery icon at the top of the reader turns on.	Replace or recharge the NiCad battery pack immediately because you are about to lose RF communications. If the Battery icon turns on and the reader beeps, RF communications are turned off. You can continue to collect data with the reader, but the data is not being transmitted to the RF network.
RF communications appear to be locked up and the Connect icon turns off.	There are three possible solutions: <ol style="list-style-type: none">1. Check the NiCad battery pack. If the battery pack charge is low, replace or recharge the battery pack immediately.2. Make sure you are within range of a radio repeater or base radio unit.3. Press the  button twice to partially reset the RF interface. Perform a warm boot on the JANUS RF device (press the    keys in sequence) and contact your Intermec service representative. When you warm boot the JANUS RF device, you will lose any data stored in the RF interface.

Troubleshooting Your J2050













If you are having problems with RF communications, review the following list of problems and their possible solutions.

You can also use network management commands (\$+NM..) to troubleshoot the RF interface. For help on using network management commands for troubleshooting, refer to your controller user's manual.

Problem	Solution
The RF option is not listed in the Com menu of IC.EXE.	The J2050 is not recognizing the RF interface. Contact your Intermec service representative.
You load the RF protocol handler and do not receive the message Intermec RF Protocol Handler.	The RF interface is not responding. Contact your Intermec service representative.



Troubleshooting Your J2050 (continued)

Problem	Solution
<p>RF communications appear to be locked up and the Connect LED turns off.</p>	<p>There are three possible solutions:</p> <ol style="list-style-type: none"> 1. Make sure you are within range of a radio repeater or base radio unit. 2. Press the  button twice to partially reset the RF interface. If that does not work, perform a warm boot on the J2050 (press the     keys in sequence) and contact your Intermec service representative. When you warm boot the J2050, you will lose any data stored in the RF interface. 3. Press the  button. Press  -  -  and then press . Press the  button to turn the J2050 back on. At the Boot Loader menu, select Storage mode. With the J2050 in storage mode, wait 60 seconds and then press  again. This sequence will cold start the radio, reboot the JANUS RF device, and restart the application.

Configuring Your JANUS RF Device

There are three ways you can configure the RF configuration parameters on your JANUS RF device:

- Use RF communications to change a few parameters.
- Use the Interactive Configuration application (IC.EXE).
- Scan bar code labels.

Each one of these methods is described in this section.

Using RF Communications

Once you have initially configured the JANUS RF device for your system, you can change the JANUS RF device's configuration by transmitting configuration command strings over the RF link to the IRL Desktop or any application that specifically uses Reader Services' input manager. Your JANUS PSK reference manual describes how to use Reader Services.

The following configuration parameters can be changed by transmitting commands to the JANUS RF device over the RF link:

- Acknowledgment Delay
- Duty Cycle Percent
- Duty Cycle Period

JANUS 900 MHz Radio Frequency Quick Reference Guide

- Repeat Count
- Retry Limit

The commands must include the prefix `..$+`.

For example, to set the Duty Cycle Percent parameter to 50%, you would send the command string:

```
..$+RY5
```

Using the Interactive Configuration Application

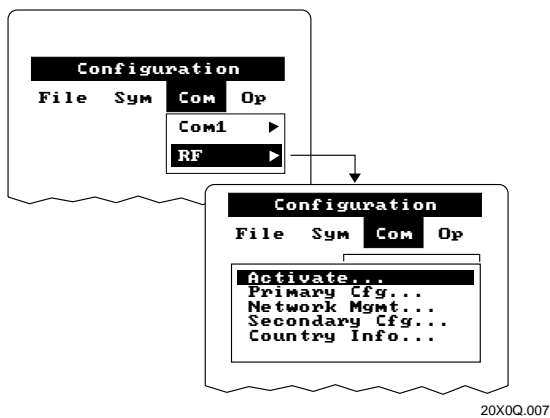

1. On the JANUS RF device, type `ic` and press . The main menu appears.
2. From the main menu bar, select `Com`.
3. From the `Com` dropdown menu, select `RF`.
4. Select one of the `RF` menu options to configure.

Select this RF menu option	To configure this RF configuration parameter	Notes
Activate	RF Protocol	Set RF Protocol to enable or disable.
Primary Cfg	Device Address Channel Select Network ID	If Network ID=0, choose Next to set RFNC Address and Repeat Count. If Network ID=1, choose Next to set Channel Allow.
Network Mgmt	Loopback Broadcast Receipt	
Secondary Cfg	Acknowledgment Delay	Choose Next to set Retry Limit, Duty Cycle Percent, and Duty Cycle Period.
Country Info	None	This option provides a list of the countries that the JANUS RF device is configured for and the frequencies available.

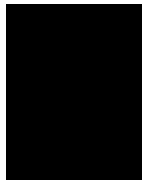

Scanning Bar Code Labels

You can scan bar code labels to configure each RF configuration parameter. The next section, “RF Configuration Parameters,” lists all the parameters and includes the procedure you use to configure your JANUS RF device.

Parameters can be enabled or disabled, or you can enable the parameter by setting a specific value. Always scan the bar code labels to enable/disable the parameter and set a value (if necessary).

Note: You cannot use the JANUS RF device’s keypad to enter a value.

For help on how to change the JANUS RF device’s configuration, refer to your JANUS user’s manual.

RF Configuration Parameters

This section lists in alphabetical order the configuration parameters that you use to configure the JANUS RF device for RF communications. For help, see “Scanning Bar Code Labels” earlier in this guide.

Note: If you have a 9185 controller, follow the instructions for the 9180 controller with version 2.0 software.

Acknowledgment Delay

Purpose: Determines the length of time the JANUS RF device should wait for a response from the network controller after it has sent a message. If a response is not received within the specified time, the JANUS RF device attempts to transmit the message again.

Default: 100 ms

Syntax: RMdata

Acceptable values for *data* are 0, and 20 through 100 (100 ms through 500 ms).

Note: If you are using IC.EXE, simply enter the number of milliseconds you want for the acknowledgment delay.

To calculate the correct value for *data*, divide the number of milliseconds you want for the acknowledgment delay by 5. For example, to have a duty cycle of 200 ms, scan 40.

If you scan zero, the acknowledgment delay has a default delay of 100 ms.

JANUS 900 MHz Radio Frequency Quick Reference Guide

Scan:

1. Scan this bar code:

Enter Accumulate Mode / ACK Delay



+/\$+RM

2. Scan a numeric value for *data* from these bar codes:



0



5



1



6



2



7



3



8



4



9

3. Scan this bar code:

Exit Accumulate Mode



-/

Broadcast Receipt

Purpose: Enables the JANUS RF device to receive the time broadcast from the network controller.

Default: Enabled

Syntax: NM03*data*

Acceptable values for *data* are 0 and 1, corresponding to:

- 0 Disable
- 1 Enable

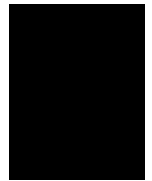

Scan: One of these labels:

Time Broadcast Receipt Disable



S+NM030

Time Broadcast Receipt Enable



S+NM031

Channel Allow

Note: You can set this parameter in IC.EXE by choosing Network ID, setting Network ID=1, and choosing Next.

Purpose: Specifies which frequencies the JANUS RF device can search when it is channel searching. The frequencies selected for Channel Allow must match the frequencies used by the network controller. However, selecting more frequencies than necessary will slow down the JANUS RF device.

The frequency you set for the Channel Select parameter is automatically included in a channel search and does not need to be set for Channel Allow.

Note: If your 9180 Network Controller has version 1.3 or earlier software, you do not need to set this parameter.

For help on channel searching, see the Network ID parameter.

Default: All channels are excluded from the search pattern.

Syntax: R{channel}{data}

Acceptable values for *channel* are:

- 0 924 MHz
- 1 921 MHz
- 2 918 MHz
- 3 915 MHz
- 4 912 MHz
- 5 909 MHz
- 6 906 MHz

Acceptable values for *data* are:

- 0 The channel is excluded from any search pattern.
- 1 The channel is searched.

JANUS 900 MHz Radio Frequency Quick Reference Guide

Scan:

1. Scan this bar code:

Enter Accumulate Mode / Channel Allow



+ / S+R

2. Scan a numeric value (0 to 6) for *channel* from these bar codes:



0



4



1



5



2



6



3

3. Scan a 0 or 1 for *data* from these bar codes:



0



1

4. Repeat Steps 2 and 3 to enable all channels you are using.
5. Scan this bar code:

Exit Accumulate Mode



*- / *

Channel Select

Purpose:

Determines the base frequency over which the JANUS RF device communicates with the network controller. The frequency selected must match the frequency used by the network controller.

Note: If your 9180 controller has version 2.0 software, set Channel Select to the initial frequency the JANUS RF device should use whenever the system is reset. This frequency is automatically included in a channel search and does not need to be set in the Channel Allow parameter.



Note: If your 9180 controller has version 1.3 or earlier software, set Channel Select to the frequency the JANUS RF device uses for communications.

Default: 924 MHz

Syntax: RVdata

Acceptable values for *data* are 0 through 6, which correspond to these frequencies:

0	924 MHz	4	912 MHz
1	921 MHz	5	909 MHz
2	918 MHz	6	906 MHz
3	915 MHz		

Scan: One of these labels:

924 MHz

 S+RV0

912 MHz

 S+RV4

921 MHz

 S+RV1

909MHz

 S+RV5

918 MHz

 S+RV2

906 MHz

 S+RV6

915 MHz

 S+RV3

Device Address

Purpose: Assigns the JANUS RF device an address. This address is used by the host computer to identify a JANUS RF device. The table on the following page lists all possible addresses and their corresponding addresses that are used by the controller (host address). Each local device such as the JANUS RF device must have a unique address.

Note: If a JANUS RF device is going to communicate with more than one network controller, it must be assigned the same Device Address on each network controller.

JANUS 900 MHz Radio Frequency Quick Reference Guide

Default: 0 (turned off)

Note: Once the Device Address parameter is set, you can only set the address to the default value (0) by loading the default configuration in IC.EXE. For help setting the JANUS RF device to the default configuration, see your JANUS user's manual.

Syntax: RHdata

Acceptable values for *data* are 1 through 128. The value for *data* must correspond to the host address as shown in the table on the following page.

Scan: 1. Scan this bar code:

Enter Accumulate Mode / RF Device Address



+/\$+RH

2. Scan a numeric value for *data* from these codes:



0



5



1



6



2



7



3



8



4



9

3. Scan this bar code:

Exit Accumulate Mode



-/

A message from the host computer must include the host address as the first two characters of the message. These two characters indicate the JANUS RF device that should receive the message. The value for *data* should correspond to the host address used by the network controller for that JANUS RF device.



Host Address/Device Address Correspondence

Host Address	Device Address <data>	Host Address	Device Address <data>	Host Address	Device Address <data>	Host Address	Device Address <data>
s		s		s		s	
mA	1	nA	33	oA	65	pA	97
mB	2	nB	34	oB	66	pB	98
mC	3	nC	35	oC	67	pC	99
mD	4	nD	36	oD	68	pD	100
mE	5	nE	37	oE	69	pE	101
mF	6	nF	38	oF	70	pF	102
mG	7	nG	39	oG	71	pG	103
mH	8	nH	40	oH	72	pH	104
mI	9	nI	41	oI	73	pI	105
mJ	10	nJ	42	oJ	74	pJ	106
mK	11	nK	43	oK	75	pK	107
mL	12	nL	44	oL	76	pL	108
mM	13	nM	45	oM	77	pM	109
mN	14	nN	46	oN	78	pN	110
mO	15	nO	47	oO	79	pO	111
mP	16	nP	48	oP	80	pP	112
mQ	17	nQ	49	oQ	81	pQ	113
mR	18	nR	50	oR	82	pR	114
mS	19	nS	51	oS	83	pS	115
mT	20	nT	52	oT	84	pT	116
mU	21	nU	53	oU	85	pU	117
mV	22	nV	54	oV	86	pV	118
mW	23	nW	55	oW	87	pW	119
mX	24	nX	56	oX	88	pX	120
mY	25	nY	57	oY	89	pY	121
mZ	26	nZ	58	oZ	90	pZ	122
m0	27	n0	59	o0	91	p0	123
m1	28	n1	60	o1	92	p1	124
m2	29	n2	61	o2	93	p2	125
m3	30	n3	62	o3	94	p3	126
m4	31	n4	63	o4	95	p4	127
m5	32	n5	64	o5	96	p5	128

Duty Cycle Percent

Note: You can set this parameter in IC.EXE by choosing Acknowledgment Delay and then choosing Next.

Purpose: Defines how long the RF interface is powered on compared to how long it is in standby. Standby uses less power, which allows the reader to conserve battery power, but the RF interface does not receive messages from the network controller. The total amount of time the RF interface is powered on plus the amount of time it is in standby is set by the duty cycle period.

For example, if Duty Cycle Period is set to 1 second, a 30% duty cycle means the RF interface is powered on for 300 ms and then is in standby for 700 ms. A 100% duty cycle means the RF interface is always on.

Note: The Duty Cycle Percent parameter significantly affects the reader's battery life. Longer duty-cycle-on periods result in a shorter battery life but higher system throughput. If you have a 9180 controller with version 2.0 software, you have a greater chance of missing broadcast messages when the duty cycle is set to a lower value.

Default (readers): 30% duty cycle on

Default (J2050): 100% duty cycle on

Syntax: RYdata

Acceptable values for *data* are 0 through 9, corresponding to:

0	100% duty cycle on	5	50% duty cycle on
1	90% duty cycle on	6	40% duty cycle on
2	80% duty cycle on	7	30% duty cycle on
3	70% duty cycle on	8	20% duty cycle on
4	60% duty cycle on	9	10% duty cycle on

Scan: 1. Scan this bar code:

Enter Accumulate Mode / Duty Cycle



+/S+RY

2. Scan a numeric value for *data* from these bar codes:



0



5

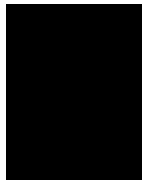

1



2



3



4



6



7



8



9

3. Scan this bar code:

Exit Accumulate Mode



-/

Duty Cycle Period

Note: You can set this parameter in IC.EXE by choosing Acknowledgment Delay and then choosing Next.

Purpose:

Defines the length of time the RF interface is powered on plus the amount of time it is in standby. The percent of time the RF interface is powered on in this time period is determined by the duty cycle percent. The duty cycle settings are used to conserve battery power. In standby, the RF interface does not receive messages from the network controller.

For example, if Duty Cycle Period is set to 1 second, a 30% duty cycle means the RF interface is powered on for 300 ms and then is in standby for 700 ms. A 100% duty cycle means the RF interface is always on.

Default:

1 second

Syntax:

RXdata

Acceptable values for *data* are 0 through 100 (100 ms to 10 seconds).

Note: If you are using IC.EXE, simply enter the number of milliseconds you want for the duty cycle period.

JANUS 900 MHz Radio Frequency Quick Reference Guide

To calculate the correct value for *data*, divide the number of milliseconds you want for the duty cycle period by 100. For example, to have a duty cycle of 200 ms, scan 2.

If you scan zero, the duty cycle period has a default delay of 1 second.

Scan:

1. Scan this bar code:

Enter Accumulate Mode / Duty Cycle Period



+ / S + RX

2. Scan a numeric value for *data* from these bar codes:



0



5



1



6



2



7



3



8



4



9

3. Scan this bar code:

Exit Accumulate Mode



*- / *



Loopback

Purpose: Transmits all messages received from the network controller back to the controller. Messages received by the RF interface are not passed on to the JANUS RF device unless they are configuration commands (..\$+NM, ..\$+RX, etc.). Messages continue to be looped back to the controller as long as this feature is enabled. Messages originating from the JANUS RF device are still transmitted to the controller.

Use the Loopback parameter to troubleshoot RF communications problems.

Default: Disabled

Syntax: NM02data

Acceptable values for *data* are 0 and 1, corresponding to:

- 0 Disable
- 1 Enable

Scan: One of these labels:

Loopback Disable



\$+NM020

Loopback Enable



\$+NM021

Network ID

Purpose: Enables the channel search feature on the JANUS RF device. This feature lets the JANUS RF device search for an open frequency to transmit data if it cannot establish communications over its current frequency.

Note: If your 9180 controller has version 2.0 software, you must set the network ID on the JANUS RF device. The device's network ID must match the network ID on the network controller. You must also set the Channel Allow parameter to identify the additional channels that can be used in channel search.

Note: If your 9180 controller has version 1.3 or earlier software, set the network ID to 0 and set the RFNC Address and Repeat Count parameters.

JANUS 900 MHz Radio Frequency Quick Reference Guide

For help on selecting the frequencies the JANUS RF device can search for, see the Channel Allow parameter.

Default: Channel search disabled

Syntax: *RWdata*

Acceptable values for *data* are:

- 0 Disable
- 1 to 254 Used by the JANUS RF device during a channel search to locate the BRUs connected to its network controller

Scan: 1. Scan this bar code:

Enter Accumulate Mode / Network ID



+/\$+RW

2. Scan a numeric value for *data* from these bar codes:



0



5



1



6



2



7



3



8



4



9

3. Scan this bar code:

Exit Accumulate Mode



-/



Repeat Count

Note: You can set this parameter in IC.EXE by choosing Network ID, setting Network ID=0, and choosing Next.

Purpose: Defines the number of times the message is sent from the radio repeaters. The JANUS RF device attaches this information to every message it sends. When a repeater receives a message, it checks the repeat count field. If the field is not zero, it decrements the repeat count and transmits the message. When the field is zero, this indicates the message has reached the BRU.

Note: If your 9180 controller has version 2.0 software, you do not need to set this parameter.

Note: If your 9180 controller has version 1.3 or earlier, you need to set this parameter.

Default: No repeaters (0)

Syntax: RUdata

Acceptable values for *data* are 0 through 7, representing the maximum number of repeaters a message would ever have to go through to get to the network controller.

Scan: One of these labels:

Repeat Count 0



\$+RU0

Repeat Count 1



\$+RU1

Repeat Count 2



\$+RU2

Repeat Count 3



\$+RU3

Repeat Count 4



\$+RU4

Repeat Count 5



\$+RU5

Repeat Count 6



\$+RU6

Repeat Count 7



\$+RU7

Retry Limit

Note: You can set this parameter in IC.EXE by choosing Acknowledgment Delay and then choosing Next.

Purpose: Defines the number of times a message that requires a response should be transmitted when no response is received within the acknowledgment delay time setting. If a response is not received, the retry count is incremented and the message is transmitted again.

Note: If your 9180 controller has version 2.0 software, the JANUS RF device searches for another frequency when the retry count equals the retry limit.

Note: If your 9180 controller has version 1.3 or earlier software, the JANUS RF device continues trying to transmit the message, but at a slower rate when the retry count equals the retry limit.

Default: 0 (optimized setting)

Syntax: RLdata

Acceptable values for *data* are 0 through 15.



Scan:

1. Scan this bar code:

Enter Accumulate Mode / Retry Limit



+/\$+RL

2. Scan a numeric value for *data* from these bar codes:



0



5



1



6



2



7



3



8



4



9

3. Scan this bar code:

Exit Accumulate Mode



-/

RF Protocol

Purpose: Enables RF communications between the JANUS RF device and the controller.

Default: Enabled

Syntax: RF*data*

Acceptable values for *data* are 0 and 1, corresponding to:

0 Disable

1 Enable

JANUS 900 MHz Radio Frequency Quick Reference Guide

Scan: One of these labels:

RF Protocol Disable



S+RF0

RF Protocol Enable



S+RF1

RFNC Address

Note: You can set this parameter in IC.EXE by choosing Network ID, setting Network ID=0, and choosing Next.

Purpose: Identifies the network controller with which the JANUS RF device is trying to communicate. The value set on the network controller determines the device's setting. The table on the following page lists the network controller address and the corresponding setting for the JANUS RF device.

Note: If your 9180 controller has version 2.0 software, you do not need to set this parameter.

Note: If your 9180 controller has version 1.3 or earlier, you need to set this parameter.

Default: RFNC 0

Syntax: RTdata

Acceptable values for *data* are 0 through 62 (even numbers only). The value for *data* must correspond to the address of the network controller as shown in the table later in this section.

Scan: 1. Scan this bar code:

Enter Accumulate Mode / RFNC Address



+/S+RT

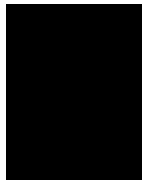

2. Scan a numeric value for *data* from these bar codes:



0



5



1



6



2



7



3



8



4



9

3. Scan this bar code:

Exit Accumulate Mode



_/

The value for *data* should correspond to the address set on the network controller. All addresses apply to downline port 1 on the network controller.

JANUS 900 MHz Radio Frequency Quick Reference Guide

Network Controller Address

Network Controller	Address <data>	Network Controller	Address <data>
0	0	16	32
1	2	17	34
2	4	18	36
3	6	19	38
4	8	20	40
5	10	21	42
6	12	22	44
7	14	23	46
8	16	24	48
9	18	25	50
10	20	26	52
11	22	27	54
12	24	28	56
13	26	29	58
14	28	30	60
15	30	31	62

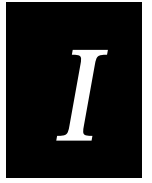

Index

A

Acknowledgment Delay, 17, 18, 19
 address
 device, 23
 RFNC, 34
 antenna, 8–10
 attaching, 8

B

base radio unit, in an RF system, 7
 battery
 Duty Cycle Percent, 26
 Duty Cycle Period, 27
 maximizing life, 14
 using duty cycle, 15
 Battery icon
 using for troubleshooting, 16
 Broadcast Receipt, 18, 20
 BRU, *See* base radio unit

C

Channel Allow, 12, 18, 21
 channel search
 enabling, 29
 setting radio frequencies, 21
 Channel Select, 11, 12, 18, 22
 COM4, 12, 13
 Communications Manager, using for RF
 communications, 13
 configuration application, *See* IC.EXE
 configuring
 RF configuration parameters, 10, 17
 using the RF link, 17
 Connect icon or LED, described, 14
 Connect icon, using for troubleshooting, 16
 Connect LED, using for troubleshooting, 17
 controller
 configuring for version 1.3 or earlier, 11
 configuring for version 2.0, 11
 configuring the JANUS RF device for different
 software versions, 11
 in an RF system, 7

D

data collection system, RF, 7
 Data icon or LED, described, 14
 default
 reader configuration, 24
 RF configuration parameters, 10
 Device Address, 11, 12, 18, 23
 Duty Cycle Percent, 15, 17, 18, 26
 managing battery power, 26

Duty Cycle Period, 15, 17, 18, 27
 managing battery power, 27

I

IC.EXE
 using, 18
 using to set up RF communications, 17
 icons
 connect, 14
 data, 14
 understanding, 13
 Interactive Configuration application, *See* IC.EXE
 Interlnk/Intersvr, using, 13
 IRL Desktop, using for RF communications, 13

J

J2050
 default configuration, 10
 troubleshooting, 16
 understanding the RF status LEDs, 13
 JANUS PSK reference manual, 17
 JANUS readers, *See also* JANUS RF devices
 managing battery power, 14
 troubleshooting, 15
 using the RF status icons, 13
 JANUS RF devices
 configuring, 17
 configuring for different controller software versions,
 11
 default configuration, 10
 enabling RF communications, 33
 in an RF system, 7
 loading the RF protocol handler, 12
 unloading the RF protocol handler, 12
 using RF communications, 13

L

LEDs
 connect, 14
 data, 14
 understanding, 13
 loading the RF protocol handler, 12
 Loopback, 18, 29
 losing RF communications, 14, 15, 16

N

Network ID, 11, 12, 18, 29

P

power management, optimizing, 14
 problems with RF communications, 15, 16

JANUS 900 MHz Radio Frequency Quick Reference Guide

R

- radio frequency
 - setting for channel search, 21
 - setting the base frequency, 22
- radio repeater
 - in an RF system, 7
 - setting Repeat Count, 31
- reader
 - default configuration, 10
- readers, *See also* JANUS RF devices
- Repeat Count, 11, 18, 31
- Retry Limit, 18, 32
- RF communications
 - configuring, 10
 - by scanning bar code labels, 17, 19
 - the JANUS RF device
 - for network controller software versions, 11
 - using configuration application, 17
 - using IC.EXE, 18
 - using the RF link, 17
 - enabling RF protocol, 33
 - loading the RF protocol handler, 12
 - losing, 14
 - managing battery power, 14
 - setting up, 8
 - switching to serial communications, 13
 - troubleshooting, 15, 16
 - understanding the RF status icons and LEDs, 13
 - unloading the RF protocol handler, 12
 - using, 13
 - using Interlnk/Intersvr, 13
- RF configuration parameters
 - Acknowledgment Delay, 17, 18, 19
 - Broadcast Receipt, 18, 20
 - changing, 11, 17
 - by scanning bar code labels, 19
 - using IC.EXE, 18
 - Channel Allow, 12, 18, 21
 - Channel Select, 11, 12, 18, 22
 - configuring for different controller software versions, 11
 - configuring using the RF link, 17
 - defaults, 10
 - Device Address, 11, 12, 18, 23
 - Duty Cycle Percent, 15, 17, 18, 26
 - Duty Cycle Period, 15, 17, 18, 27
 - Loopback, 18, 29
 - Network ID, 11, 12, 18, 29
 - Repeat Count, 11, 18, 31
 - Retry Limit, 18, 32
 - RF Protocol, 18, 33
 - RFNC Address, 11, 18, 34
- RF interface, defined, 14
- RF Protocol, 18, 33

- RF protocol handler
 - loading, 12
 - troubleshooting, 15, 16
 - unloading, 12
- RF status
 - connected, 14
 - data, 14
- RF system, overview, 7
- RFNC Address, 11, 18, 34

S

- scanning bar code labels
 - using to configure RF communications, 17
 - using to configure RF configuration parameters, 19
- serial communications
 - switching to RF communications, 13
- setting up RF communications, attaching the antenna, 8
- software libraries, using for RF communications, 13
- software versions, controller
 - configuring the reader for
 - version 1.3 or earlier, 11
 - version 2.0, 11
- standby, described, 26, 27
- Storage mode, using, 15

T

- troubleshooting
 - J2010, 15
 - J2050, 16
 - JR2020, 15
 - using network management commands, 15, 16
 - using the Loopback parameter, 29

V

- Vehicle Mount Computer, *See also* JANUS RF devices.
See J2050