

TRAKKER Antares 2400 Series Module for Cabled Scanners Instruction Sheet

This module is an easy-to-install accessory for the TRAKKER® Antares™ 2420 and 2425 terminals that provide a scanner port for attaching a wand or scanner for bar code data collection.

Note: Observe all static electricity precautions before installing the module.

To install the module

1. Make sure the terminal is off and then lay it face down on a clean and sturdy work surface.
2. Remove the existing module from the terminal.
3. Align the module guides with the guides on the terminal (see illustration) and then **gently** press down on the module to seat the connector guide pins and the module connector into the connector on the terminal.

Note: The module guide pins and connector should fit easily into the connector on the terminal. **DO NOT** force the module into the connector or you may damage the module connector, the terminal connector, or both.

4. Secure the module to the terminal.

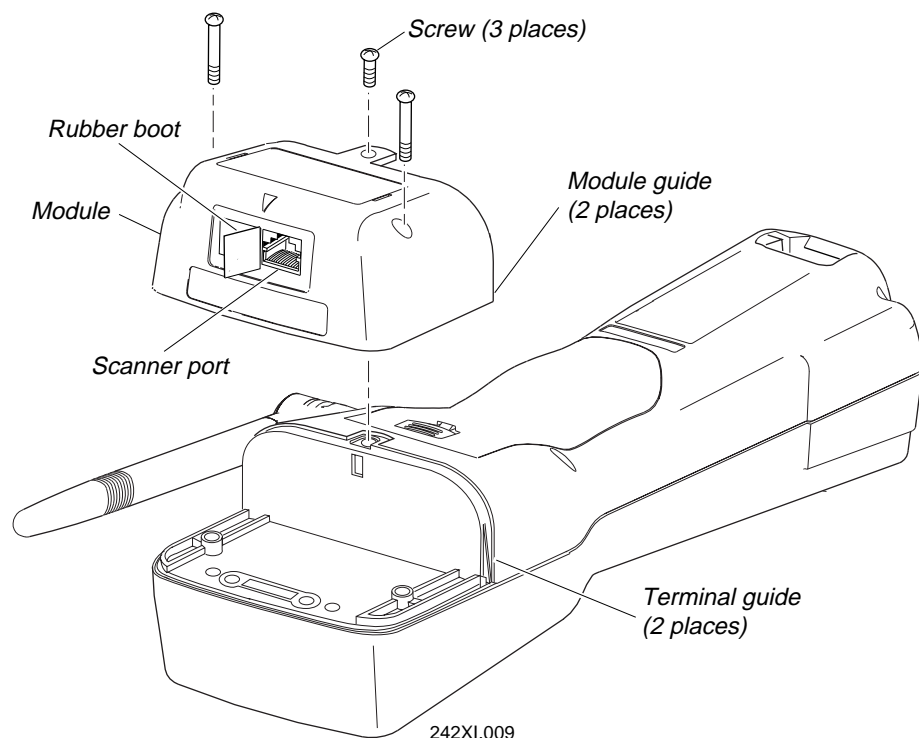

Compatible Bar Code Scanners

The following Intermec products are compatible with this module:

- 12XX Wands
- 146X CCD Scanners
- 151X, 1545, 155X, and 1565 Laser Scanners
- J7010 Hand-Held Imager

Note: You must purchase an interface cable to connect the Intermec products listed above to this module. Contact your Intermec Sales and Service representative for the proper interface cable.

Attaching a Laser Scanner

To attach a bar code laser scanner or wand to your terminal, open the rubber boot covering the scanner port, and then snap the bar code scanner connector into the port.

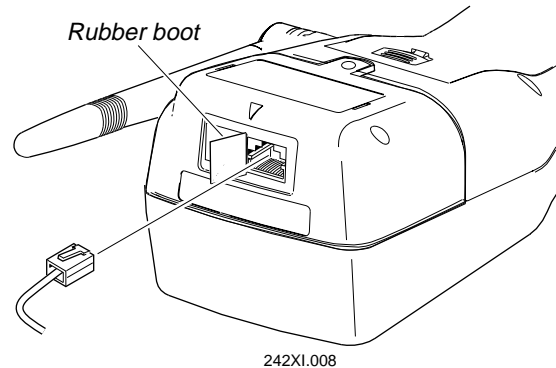

Using the J7010

To use the JANUS™ 7010 Hand-Held Imager with this module, you must:

- use a wedge interface cable (P/N 062168) to connect the J7010 to the module.
- set the Cable ID parameter on the J7010 to “Force 97XX Wedge” (\$+VC4).
- cycle the power on the J7010.

Intermec®

6001 36th Avenue West
P.O. Box 4280
Everett, WA 98203-9280

© 1996-1997 Intermec Corporation
All Rights Reserved
P/N 064219-002