



IMAGETEAM™ 4400/4700
2D Series
Hand Held Imager

Statement of Agency Compliance

This device complies with part 15 of the FCC Rules. Operation is subject to the following two conditions: (1) this device may not cause harmful interference, and (2) this device must accept any interference received, including interference that may cause undesired operation.

FCC Class B Compliance Statement

This equipment has been tested and found to comply with the limits for a Class B digital device pursuant to part 15 of the FCC Rules. These limits are designed to provide reasonable protection against harmful interference in a residential installation. This equipment generates, uses, and can radiate radio frequency energy and, if not installed and used in accordance with the instructions, may cause harmful interference to radio communications. However, there is no guarantee that interference will not occur in a particular installation. If this equipment does cause harmful interference to radio or television reception, which can be determined by turning the equipment off and on, the user is encouraged to try to correct the interference by one or more of the following measures:

- Reorient or relocate the receiving antenna.
- Increase the separation between the equipment and receiver.
- Connect the equipment into an outlet on a circuit different from that to which the receiver is connected.
- Consult the dealer or an experienced radio or television technician for help.

Caution: Any changes or modifications made to this device that are not expressly approved by Welch Allyn Data Collection, Inc. may void the user's authority to operate the equipment.

Note: To maintain compliance with FCC Rules and Regulations, cables connected to this device must be *shielded* cables, in which the cable shield wire(s) have been grounded (tied) to the connector shell.

Canadian Notice

This equipment does not exceed the Class B limits for radio noise emissions as described in the Radio Interference Regulations of the Canadian Department of Communications.

Le présent appareil numérique n'émet pas de bruits radioélectriques dépassant les limites applicables aux appareils numériques de la classe B prescrites dans le Règlement sur le brouillage radioélectrique édicté par le ministère des Communications du Canada.

CDRH Laser Safety Statement

This product complies with US DHHS 21 CFR J Part 1040.10. This product is a CLASS II LASER PRODUCT with a maximum output of 1.0 mW at 670 nanometers and continuous wave.

EN 60825-1 Laser Safety Statement

This product is classified as a CLASS 2 LASER PRODUCT with a maximum output of 1.0 mW at 670 nanometers per EN 60825-1:1994, Issue 2, June 1997.



The CE mark on the product indicates that the system has been tested to and conforms with the provisions noted within the 89/336/EEC Electromagnetic Compatibility Directive and the 73/23/EEC Low Voltage Directive.

For further information please contact:

Welch Allyn Ltd.
Block 1, Bracken Business Park
Sandyford, Co. Dublin
Ireland

or

Welch Allyn Ltd.
1st Floor
Dallam Court Dallam Lane
Warrington, Cheshire WA2 7LT
England

Welch Allyn Data Collection, Inc. shall not be liable for use of our product with equipment (i.e., power supplies, personal computers, etc.) that is not CE marked and does not comply with the Low Voltage Directive.

Patents

The IMAGETEAM 4400/4700 products are covered by one or more of the following U.S. Patents: 5,420,409, 5,780,834, 5,723,853; 5,723,868; 5,825,006; 5,900,613; 5,929,418. Other U.S. and foreign patents pending.

Scan on Demand is covered by the following patent: 5,463,214.

Image Sensor Containment System is covered by the following patent: 5,838,495.

Disclaimer

Welch Allyn[®] Data Collection, Inc. reserves the right to make changes in specifications and other information contained in this document without prior notice, and the reader should in all cases consult Welch Allyn Data Collection, Inc. to determine whether any such changes have been made. The information in this publication does not represent a commitment on the part of Welch Allyn Data Collection, Inc.

Welch Allyn Data Collection, Inc. shall not be liable for technical or editorial errors or omissions contained herein; nor for incidental or consequential damages resulting from the furnishing, performance, or use of this material.

This document contains proprietary information which is protected by copyright. All rights are reserved. No part of this document may be photocopied, reproduced, or translated into another language without the prior written consent of Welch Allyn Data Collection, Incorporated.

© 1999-2000 Welch Allyn Data Collection, Inc. All rights reserved.

Welch Allyn Data Collection, Inc. Web Address: <http://dcd.welchallyn.com>

Table of Contents

Chapter 1 - Introduction and Installation

About the Hand-Held 2D Imager	1-1
Unpacking the Imager.....	1-2
IT4400 Imager Identification.....	1-3
IT4700 Imager Identification.....	1-4
Laser and LED Safety.....	1-5
Connecting the Scanner When Powered by Host (Keyboard Wedge).....	1-6
Reading Techniques.....	1-7
Depth of Field Charts.....	1-8

Chapter 2 - Programming

Introduction.....	2-1
Reset Factory Settings	2-2
Status Check	2-2
All Symbologies	2-3
Revision Selections.....	2-3
Terminal Interface	2-4
Supported Terminals Chart.....	2-5
Keyboard Country	2-6
Keyboard Style	2-7
Keyboard Modifiers.....	2-8
Keyboard Function Relationships.....	2-9
Connecting the Scanner to a Serial Port	2-10
Communication Settings.....	2-11
Parity	2-11
Baud Rate	2-12
Word Length Data Bits	2-13
Word Length Stop Bits.....	2-13
Hardware Flow Control.....	2-14
Software Flow Control.....	2-14
Serial Triggering	2-15
Power Saving Mode.....	2-16
Power Hold Mode.....	2-16

LED Power Level.....	2-17
LED Flashing	2-17
Aimer Delay	2-18
Aimer Timeout	2-18
Aimer Interval	2-19
AutoTrigger.....	2-20
Scan Stand.....	2-20
Scan Stand LED Intensity.....	2-20
Scan Stand Lights	2-21
Presentation Mode.....	2-21
Presentation Reread Delay.....	2-21
Presentation Default	2-21
Presentation Aimer	2-22
Zoom	2-22
Zoom Placement.....	2-23
Beeper Volume.....	2-24
Power Up Beeper	2-24
Output Sequence Beeper	2-24
Beep On Decode	2-25
Beeper Default.....	2-25
Intercharacter, Interfunction, and Intermassage Delays	2-26
Intercharacter Delay	2-26
Interfunction Delay	2-27
Intermessage Delay	2-28
Prefix/Suffix Overview	2-29
Adding a Prefix or Suffix	2-30
Add a Carriage Return Suffix to All Symbologies	2-31
Add a Code I.D. Prefix to All Symbologies	2-31
Add an AIM I.D. Prefix to All Symbologies	2-31
Prefix Entries	2-32
Suffix Entries	2-32
Symbology Chart	2-33
Decimal to Hex to ASCII Conversion Chart.....	2-34

Data Format Editor Overview	2-35
Format Editor Commands	2-36
Data Format Editor	2-38
Data Formatter	2-39
Require Data Format	2-39
Show Data Formats	2-39
Alternate Data Formats	2-40
Output Sequence Overview	2-41
Require Output Sequence	2-43
Output Sequence Editor	2-44
Multiple Symbols	2-45
No Read	2-45
Print Weight	2-46

Chapter 3 - Symbologies

Introduction	3-1
Codabar	3-2
Start/Stop Characters	3-2
Message Length	3-2
Check Character	3-3
Code 39	3-4
Start/Stop Characters	3-4
Message Length	3-4
Full ASCII	3-5
Check Character	3-6
Interleaved 2 of 5	3-7
Message Length	3-7
Check Digit	3-8
Iata 2 of 5	3-9
Message Length	3-9
Code 93	3-10
Message Length	3-10
Code 128	3-11
Message Length	3-11
ISBT	3-12

EAN/JAN 8	3-13
Check Digit.....	3-13
EAN/JAN 13	3-14
Check Digit.....	3-14
EAN Addenda	3-15
UPC A	3-16
Check Digit.....	3-16
Number System	3-16
UPC E0.....	3-17
Check Digit.....	3-17
Number System	3-17
Version E Expand.....	3-18
UPC E1.....	3-18
UPC Addenda.....	3-18
RSS-14	3-19
RSS-14 Limited.....	3-19
RSS-14 Expanded	3-20
Message Length.....	3-20
Codablock	3-21
Message Length.....	3-21
PDF417	3-22
Message Length.....	3-22
Micro PDF417.....	3-23
Message Length.....	3-23
Code 49	3-24
Message Length.....	3-24
Composite Codes	3-25
Message Length.....	3-25
U.S. Postal Service POSTNET Code	3-26
Planet Code	3-26
British Post Office 4 State Code	3-26
Canadian 4 State Code	3-26
Dutch Postal Code.....	3-26
Australian 4 State Code.....	3-27
Japanese Postal Service.....	3-27
QR Code.....	3-28
Message Length.....	3-28

Data Matrix.....	3-29
Message Length	3-29
MaxiCode	3-30
Message Length	3-30
Structured Carrier Message Only	3-31
Aztec Code	3-32
Message Length	3-32
VeriCode	3-33
VeriCode Size	3-34
Test Menu.....	3-35
2D Scan Diagnostics	3-35

Chapter 4 - OCR Programming

Introduction	4-1
OCR.....	4-2
Creating OCR Templates	4-3
Creating an OCR Template.....	4-3
Stringing Together Multiple Formats (Creating “Or” Statements).....	4-5
Creating a User-Defined Variable	4-6
Adding an OCR Check Character.....	4-6
OCR Template Codes	4-7

Chapter 5 - Default Charts

Communication (RS-232) Selections	5-1
Imager Selections.....	5-1
Prefix/Suffix Selections	5-2
Data Formatter Selections.....	5-2
Output Sequence Selections.....	5-2
Linear Symbolologies	5-3
Postal Symbology Selections.....	5-5
2D Matrix Selections	5-5

Chapter 6 - Quick*View

Quick*View Demonstration Software Instructions	6-1
Setting Up the Imager and the Quick*View Software ...	6-1
Installing Quick*View from the Web	6-2
Using the Quick*View Software	6-3
Electronic Parts Manufacturing Demonstration	6-6
Patient Registration Demonstration.....	6-8
Bills of Lading Demonstration	6-9
Load New Imager Software	6-14
Serial Programming Commands.....	6-15
Status Check	6-17
Output Selections	6-17
Communication Settings	6-18
Imager Selections	6-19
Output Selections	6-20
Prefix/Suffix Selections	6-20
Data Formatter Selections	6-21
Output Sequence Selections	6-21
Linear Symbology Selections	6-21
Stacked Symbology Selections	6-25
Postal Symbology Selections	6-25
2D Matrix Symbology Selections	6-26

Chapter 7 - Visual Menu

Visual Menu Introduction	7-1
Installing Visual Menu from the Web.....	7-2

Chapter 8 - Interface Keys

Chapter 9 - Product Specifications & Pinouts

Product Specifications.....	9-1
Cable Pinouts	9-3
RS-232 Output, external power (IT4400 and IT4700) ...	9-3
IT4400 Dimensions.....	9-4
IT4700 Dimensions.....	9-5

Chapter 10 - Maintenance & Troubleshooting

Repairs.....	10-1
Maintenance	10-1
Replacing the Interface Cable	10-2
Troubleshooting.....	10-4
Application Support.....	10-5

Chapter 11 - Customer Support

Obtaining Factory Service.....	11-1
Limited Warranty	11-3

Sample Symbols

Programming Chart



About the Hand-Held 2D Imager

The hand-held 2D Imager is an economical, durable solution for a wide variety of data collection applications. The Imager features the following:

- A tough, ergonomic thermoplastic housing for comfort and durability.
- Omni-directional reading of a variety of printed symbols, including the most popular linear and 2D matrix symbologies.
- Advanced binary optics for ease of aiming and framing labels.
- RS-232, keyboard wedge, and laser emulation communication outputs.
- The ability to capture and download images to a PC for signature capture software applications, and PC-based decoding.
- The ability to read single line OCR-A and OCR-B fonts.

About this Manual

This user's guide provides installation instructions for the hand-held Imager. The chapters contain the following information:

- Chapter 1 Unpacking and installing the Imager
- Chapter 2 Programming selections
- Chapter 3 Symbology programming selections
- Chapter 4 OCR programming
- Chapter 5 Default settings
- Chapter 6 Quick*View software information and serial programming commands
- Chapter 7 Visual Menu software
- Chapter 8 Interface Keys
- Chapter 9 Product specifications and connector pinout listings
- Chapter 10 Maintenance and troubleshooting
- Chapter 11 Customer support, service information, and warranty

Unpacking the Imager

Open the carton. The shipping carton or container should contain:

IMAGETEAM 4400:



IMAGETEAM 4400
Hand Held Imager

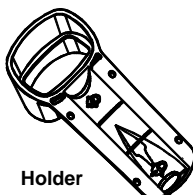

Holder



User's Guide

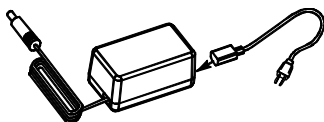

Universal Power Supply
and Power Cable

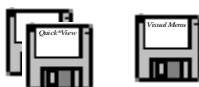

Demonstration
Diskettes

IMAGETEAM 4700:

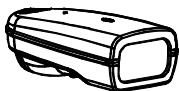

IMAGETEAM 4700
Hand Held/Fixed
Mount Imager

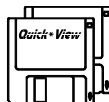

Demonstration
Diskettes



User's Guide

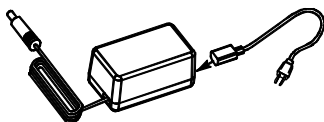

Universal Power Supply
and Power Cable

- Check to make sure everything you ordered is present.
- Save the shipping container for later storage or shipping.
- Check for damage during shipment. Report damage immediately to the carrier who delivered the carton.

IT4400 Imager Identification



Enlarged View of Label

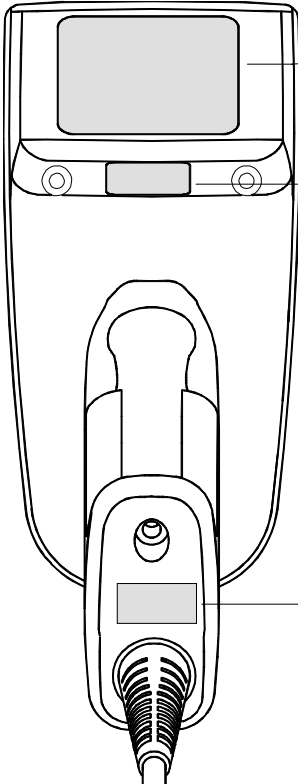

Model# = 4400XX-XX
 Manufactured = July 1999
 Serial # = P-12-34567
 S/W = 34567001/4400 **CE**

Hand Held IT4400 Imager
 Bottom View

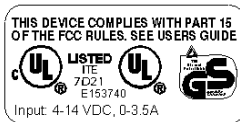

IT4700 Imager Identification

▲ AVOID EXPOSURE- LASER LIGHT IS EMITTED FROM THIS APERTURE ▲
ÉVITER TOUTE EXPOSITION-LUMIÈRE LASER ÉMIS PAR CETTE OUVERTURE.
LASER LIGHT - DO NOT STARE INTO BEAM
CLASS 2 LASER PRODUCT. 670nm LASER DIODE. 1.0 mW MAX OUTPUT
LASERLICHT NICHT IN DEN STRAHL BLICKEN! LASER LASER KLASSE 2
LUMIÈRE LASER NE PAS REGARDER DANS LE FAISCEAU APPAREIL A
LASER DE CLASSE 2

CAUTION

LASER LIGHT
DO NOT STARE INTO BEAM
670 nm LASER DIODE
1.0 mW MAX OUTPUT
CLASS II LASER PRODUCT

COMPLIES WITH US
DHHS 21CFR J 1040.10
& EN60825-1:1994

Made in USA

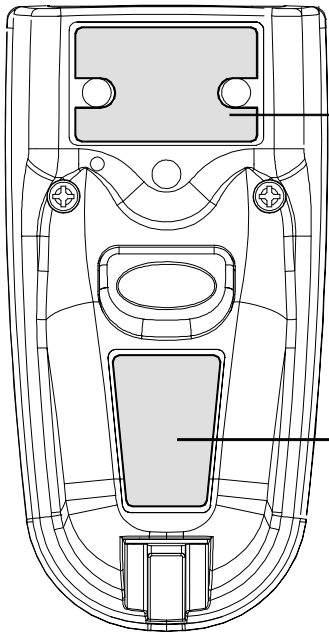



Enlarged View of Label

Hand Held IT4700 Imager Bottom View

WELCH ALLYN, INC.
SKANEATELES FALLS, NY 13153

IT4700

ITEM #
DATE/SN:
S/W REV:
 Welch Allyn, Skaneateles Falls
 NEW YORK 13153

 LISTED
 IEC
 71521
 E163740



THIS DEVICE COMPLIES WITH PART
 16 OF THE FCC RULES - PART 15
 GUIDE.

Laser and LED Safety

The Laser Aiming subsystem projects 670 nm laser light onto the bar code target to define the optical field of view. The projected pattern consists of a central cross and four 90 degree corner sections. This pattern is generated by a lens and diffractive component positioned at the output of the enclosed laser diode. This projected pattern assists the operator to frame the bar code being scanned.

The Good Read Indicator and the LED Illumination Array have been tested in accordance with the specification "Safety of Laser Products" EN 60825-1:1994, Issue 2, June 1997 and found to satisfy the requirements of Class 1. Class 1 optical systems are considered safe under reasonably foreseeable conditions of operation. The Aiming Laser has been tested in accordance with the specification "Safety of Laser Products" EN 60825-1:1994, Issue 2, June 1997 and found to satisfy the requirements of Class 2. Class 2 systems are considered to emit visible radiation in the wavelength range from 400 nm to 700 nm. Eye protection is normally afforded by aversion responses including the blink reflex. It is recommended that you do not stare into the beam or cause others to stare into the beam.

Connecting the Scanner When Powered by Host (Keyboard Wedge)

A scanner can be connected between the keyboard and PC as a "keyboard wedge," plugged into the serial port, or connected to a portable data terminal in wand emulation or non decoded output mode.

Note: Only units ordered from the factory with keyboard wedge capability can be connected as keyboard wedge units.

The following is an example of a keyboard wedge connection:

1. Turn off power to the terminal/computer.
2. Disconnect the keyboard cable from the back of the terminal/computer.

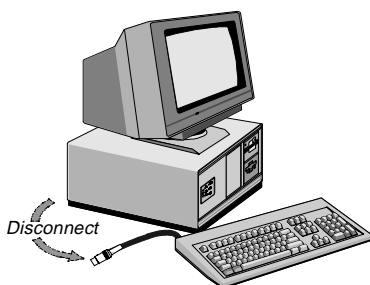

3. Connect the appropriate interface cable to the scanner and to the terminal/computer. The scanner will beep twice.
4. Turn the terminal/computer power back on.
5. Verify the scanner operation by scanning a bar code from the back cover of this manual. The scanner will beep once.

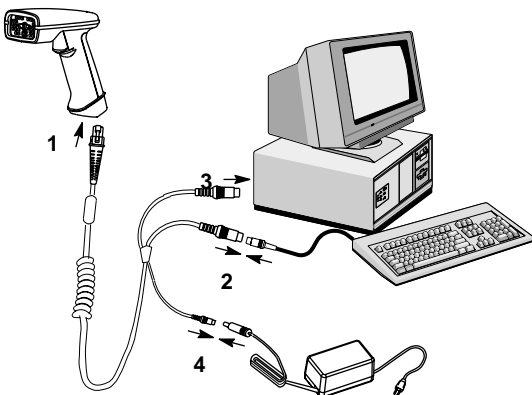

The scanner is now connected and ready to communicate with your terminal/PC. You must program the scanner for your interface before bar code data can be transmitted to your terminal/PC. If you are using the scanner as a keyboard wedge, see "Terminal Interface" on page 2-4. If the scanner is connected via a serial port, turn to "Connecting the Scanner to a Serial Port" on page 2-10.

Reading Techniques

The hand-held Imager has a view finder (shown below) which is similar to those on cameras. The view finder allows you to position the code within the field of view.

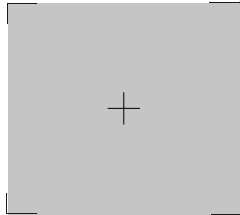

The illustration below shows where to aim the red illuminated beam over the symbol for a good read. Center the symbology in the view finder. The entire symbology must be within the view finder (aiming beam). The view finder changes size as you move the Imager closer to or farther away from a code.

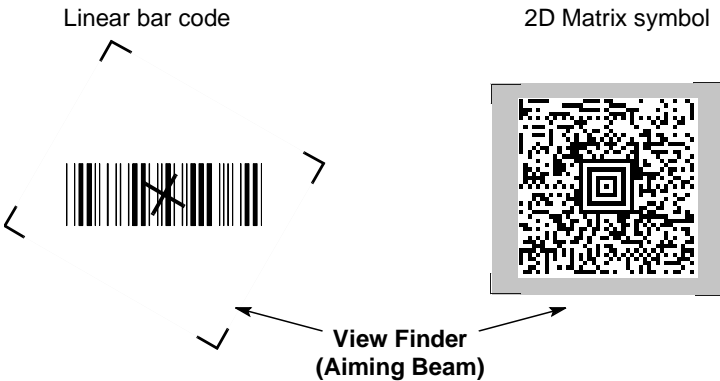

Note: The symbols can be in any orientation for the Imager to read.

The view finder is smaller when the Imager is closer to the code and larger when it is farther from the code. Symbologies with smaller bars or elements (mil size) should be read closer to the unit. Symbologies with larger bars or elements (mil size) should be read farther from the unit. (see "Depth of Field Charts " on page 1-8.) To read single or multiple symbols (on a page or on an object), hold the Imager at an appropriate distance from the target, pull the trigger, and center the view finder cross hairs on the symbol.

Depth of Field Charts

Depth of Field for High Density Imager (2" Nominal Focus)

Code Size	Near Distance	Far Distance
QR 6.6 mil (0.017 cm)	1.7 inches (4.3 cm)	2.4 inches (6.1 cm)
Data Matrix 6.6 mil (0.017 cm)	1.7 inches (4.3 cm)	2.4 inches (6.1 cm)
Linear 4 mil (0.01 cm)	1.6 inches (4.1 cm)	2.5 inches (6.4 cm)
OCR 6 pt. (20 cpi)	2 inches (5.1 cm)	3.5 inches (8.9 cm)

Depth of Field for High Density10 Imager (3" Nominal Focus)

Code Size	Near Distance	Far Distance
QR 10 mil (0.025 cm)	2.0 inches (5.1 cm)	4.0 inches (10.2 cm)
Data Matrix 10 mil (0.025 cm)	2.0 inches (5.1 cm)	3.5 inches (8.9 cm)
Linear 5 mil (0.013 cm)	2.75 inches (7.0 cm)	3.75 inches (9.5 cm)
OCR 12 pt. (12 cpi)	2 inches (5.1 cm)	5 inches (12.7 cm)

Depth of Field for Long Range Imager (5" Nominal Focus)

Code Size	Near Distance	Far Distance
Linear 7.5 mil (0.019 cm)	3.0 inches (7.6 cm)	5.0 inches (12.7 cm)
Linear 10 mil (0.025 cm)	2.5 inches (6.4 cm)	4.75 inches (12.1 cm)
Linear 15 mil (0.038 cm)	2.0 inches (5.1 cm)	7.5 inches (19.1 cm)
Data Matrix 15 mil (0.038 cm)	2.5 inches (6.4 cm)	4.0 inches (10.2 cm)
Aztec or QR 15 mil (0.038 cm)	3.5 inches (8.9 cm)	5.0 inches (12.7 cm)
Maxicode 35 mil (0.089 cm)	2.0 inches (5.1 cm)	9.0 inches (22.9 cm)

Introduction

Use this section to program the hand-held Imager.

This programming section contains the following menuing selections:

- General Selections
- Terminal Interface Selections
- Keyboard Selections
- Communication Settings
- Imager Selections
- Output Selections
- Prefix/Suffix Selections
- Data Formatter Selections
- Output Sequence Selections

Reset Factory Settings

All operating parameters are stored in nonvolatile memory resident in the Imager, where they are permanently retained in the event of a power interruption. When you receive your Imager, certain operating parameters have already been set. These are the factory defaults, indicated by the symbol “★” on the programming menu pages (beneath the default programming symbol). Default charts begin on page 5-1.

Depending on your model, scan one of the following bar codes to set the imager to the original factory settings, clearing any programming changes you may have made.



HD



HD10



LR

Status Check

Read the Show Software Revision symbol to transmit the software revision level to the host terminal. The software revision will be printed out as “REV_SW:\$ProjectRevision:1.xx\$;REV_WA:31204734-xxx.”

Read the Show Data Formats symbol to transmit the existing Data Format Editor formats. One format per line will be printed out.



Show Software
Revision



Show Data Formats

All Symbologies

If you want to decode all the symbologies allowable for your scanner, scan the All Symbologies On code.



All Symbologies
On



All Symbologies
Off

Revision Selections

Both the following programming codes would not normally be needed unless you have a problem with the unit. An Application Support Representative may request the boot code or power PC revision information in order to trouble shoot a problem.



Power PC Revision



Boot Code Revision

Terminal Interface

IMAGETEAM 4400 and 4700 scanners are factory programmed for a keyboard wedge interface to an IBM PC AT with a USA keyboard. If this is your interface and you do not need to modify the settings, skip to page 2-16 for Imager Selections.

If your interface is not a standard PC AT, refer to the "Supported Terminals Chart" on page 2-5 and locate the Terminal ID number for your PC. Scan the **Terminal ID** bar code below, then scan the numeric bar code(s) on the inside back cover of this manual to program the scanner for your terminal ID. Scan **Save** to save your selection.

For example, an IBM PS/2 terminal has a Terminal ID of 002. You would scan the **Terminal ID** bar code, then **0, 0, 2** from the inside back cover, then **Save**. If you make an error while scanning the digits (before scanning Save), scan the Discard code on the back cover and scan the digits and the Save code again.

Factory Default = 03



Terminal ID



Save

Supported Terminals Chart

Terminal	Model(s)	Terminal I.D.
DEC	PC433 SE (Portable PC)	003
DELL	Latitude (Portable PC)	003
DTK	486 SLC (Portable PC)	003
Fujitsu	Stylistic (Portable PC)	003
HHLC (Code 128 Emulation)		089*
IBM	PC X	001
IBM	PS/2 25, 30, 77DX2	002
IBM	AT, PS/2 30-286, 50, 55SX, 60, 70, 003, 70-061, 70-121, 80	
IBM	AT Compatibles Keyboard Emulation (Non-wedge)	003
IBM	Thinkpad 360 CSE, 34, 750 (Portable PC)	097
IBM	Thinkpad 365, 755 CV (Portable PC)	003
IBM	AT Thinkpad	106
Midwest	Micro Elite TS 30 PS (Portable PC)	003
Mitak	4022 (Portable PC)	003
Olivetti	M19, M24, M28, M200	001
Olivetti	M240, M250, M290, M380, P500	003
Reliasys	TR 175	003
RS-232 TTL		000
Televideo	990, 995, 9060	002
Texas Instruments	Extensa 560CD (Portable PC)	003
Toshiba	2600 (Portable PC)	003
Toshiba	Satellite T1960, T2130, CS (Portable PC)	003
Zenith	Z-note (Portable PC)	003

* This capability is not available for the IT4700. Contact the factory if this capability is needed for the IT4700.

Note: These interfaces are available only for units that have 1 megabyte of program memory. The software revision indicates the memory size. If you are not certain of your unit's memory, please contact Welch Allyn's Application Support (see page 10-5).

Keyboard Country

Scan the **Program Keyboard Country** bar code below, then scan the numeric bar code(s) from the inside back cover, then the **Save** bar code to program the keyboard for your country. As a general rule, the following characters are not supported by the scanner for countries other than the United States:

@ | \$ # { } [] = / ' \ < > ~



Keyboard Country

Country Code	Scan	Country Code	Scan
Belgium.....	1	Italy	5
Denmark	8	Norway.....	9
Finland.....	2	Spain.....	10
France	3	Switzerland	6
Germany/Austria.....	4	USA (<i>Default</i>).....	0
Great Britain	7		



Save

Keyboard Style

This programs keyboard styles, such as Caps Lock and Shift Lock. *Default = Regular.*

Regular is used when you normally have the Caps Lock key off.

Caps Lock is used when you normally have the Caps Lock key on.

Shift Lock is used when you normally have the Shift Lock key on. (Not common to U.S. keyboards.)

Automatic Caps Lock is used if you change the Caps Lock key on and off. The software tracks and reflects if you have Caps Lock on or off (AT and PS/2 only). This selection can only be used with systems that have an LED which notes the Caps Lock status.

Emulate External Keyboard should be scanned if you do not have an external keyboard (IBM AT or equivalent), but should not be used for laptops. To connect the scanner to a laptop, use "Automatic Direct Connect Mode On" on page 2-8.



* Regular



Caps Lock



Shift Lock



Automatic
Caps Lock



Emulate External
Keyboard

Keyboard Modifiers

This modifies special keyboard features, such as CTRL+ ASCII codes and Turbo Mode.

Control + ASCII Mode On - The scanner sends key combinations for ASCII control characters for values 00-1F. Refer to "Keyboard Function Relationships" on page 2-9 for CTRL+ ASCII Values. *Default = Off*



Control + ASCII
Mode On



* Control + ASCII
Mode Off

Turbo Mode - The scanner sends characters to an IBM AT terminal faster. (For use with IBM AT only.) If the terminal drops characters, do not use Turbo Mode. *Default = Off*



Turbo Mode On



* Turbo Mode Off

Numeric Keypad Mode - Sends numeric characters as if entered from a numeric keypad. *Default = Off*



Numeric Keypad
Mode On



* Numeric
Keypad Mode Off

Automatic Direct Connect - Use this selection if you are using a laptop whose keyboard is disabled when you plug in the scanner. This selection can also be used if you have an IBM AT style terminal and the system is dropping characters. *Default = Off*



Automatic Direct
Connect Mode On



* Automatic Direct
Connect Mode Off

Keyboard Function Relationships

The following Keyboard Function Code, Hex/ASCII Value, and Full ASCII "CTRL" + "CTRL" relationships apply to all terminals that can be used with the scanner.

Function Code	HEX/ASCII Value	Full ASCII "CTRL" +
NUL	00	2
SOH	01	A
STX	02	B
ETX	03	C
EOT	04	D
ENQ	05	E
ACK	06	F
BEL	07	G
BS	08	H
HT	09	I
LF	0A	J
VT	0B	K
FF	0C	L
CR	0D	M
SO	0E	N
SI	0F	O
DLE	10	P
DC1	11	Q
DC2	12	R
DC3	13	S
DC4	14	T
NAK	15	U
SYN	16	V
ETB	17	W
CAN	18	X
EM	19	Y
SUB	1A	Z
ESC	1B	[
FS	1C	\
GS	1D]
RS	1E	6
US	1F	-

Connecting the Scanner to a Serial Port

6. Turn off power to the terminal/computer.
7. Connect the interface cable to the scanner.
8. Connect the interface cable to the 5 or 14 VDC power supply and plug in the power supply. The scanner will beep twice.
9. Connect the interface cable to the terminal/computer.

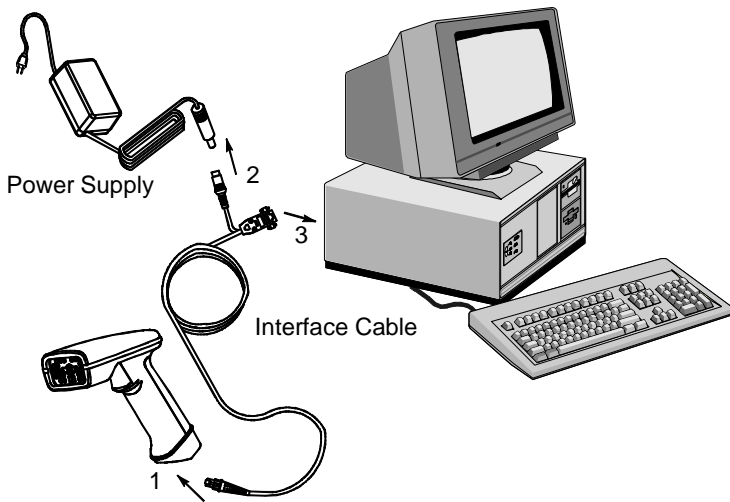

10. Turn the terminal/computer power back on.
11. Verify the scanner operation by scanning a bar code from the back cover of this manual. The scanner will beep once.

The scanner is now connected and ready to communicate with your terminal/PC. Turn to "Communication Settings" on page 2-11 to program the communication parameters for a serial interface.

Communication Settings

<Default All RS-232 Communication Settings>



Parity

Parity provides a means of checking character bit patterns for validity. The Imager can be configured to operate under Mark, Space, Odd, Even, or No (None) parity options. The host terminal must be set up for the same parity as the Imager, to ensure reliable communication.



Mark



Space



Odd



Even



* None

Baud Rate

This sets the baud rate from 300 bits per second to 115,200 bits per second (see next page). Programming baud rate causes the data to be sent at the specified rate. The host terminal must be set to the same baud rate as the Imager to ensure reliable communication.



300



600



1200



2400



4800



9600



19200



* 38400

Baud Rate, continued



57600



115200

Word Length Data Bits

You can set the Word Length at 7 or 8 bits of data per character. If an application requires only ASCII Hex characters 0 through 7F decimal (text, digits, and punctuation), select 7 data bits. For applications requiring use of the full ASCII set, select 8 data bits per character.



7 Data Bits



* 8 Data Bits

Word Length Stop Bits

Word Length can be set to one or two stop bits.



* 1 Stop Bit



2 Stop Bits

Hardware Flow Control

When hardware flow control is on, the software checks for a CTS signal before sending data. This option is useful when your application supports the CTS signal.



On



* Off

Software Flow Control

This allows control of data transmission from the Imager using software commands from the host device. When this feature is turned off, no data flow control is used. When Data Flow Control is turned on, the host device suspends transmission by sending the XOFF character (DC3, hex 13) to the Imager. To resume transmission, the host sends the XON character (DC1, hex 11). Data transmission continues where it left off when XOFF was sent.



On



* Off

Serial Triggering

This provides a means of sending a serial trigger command to start and stop decoding. When this feature is turned off, the Imager will not respond to serial trigger commands. When serial triggering is turned on, the Imager requires a serial trigger character to activate scanning and decoding. The unit continues to scan and decode bar codes until the Trigger Off character turns off the scanner, or a time out occurs.

On the "Decimal to Hex to ASCII Conversion Chart" on page 2-34, find the hex characters you want to use to turn the trigger on and off. Locate the decimal values for those characters and scan the 2 digits for each one from the Programming Chart in the back of this manual.

When Serial Triggering is On, the default Trigger On decimal character is 18 (hex 12, DC2), and the default Trigger Off decimal character is 20 (hex 14, DC4).



On



* Off



Trigger On ‡



Trigger Off ‡



* Trigger Defaults

‡ A one to three digit decimal number and Save are required after reading this programming symbol. See "Decimal to Hex to ASCII Conversion Chart" on page 2-34, and the Programming Chart (inside back cover).

Power Saving Mode

This provides control of the Imager's power consumption, as follows:

Low Power draws low LED current during image capture, allowing one read attempt *only* for each trigger pull. The Imager is less tolerant of hand movement during the read attempt, and powers down after the image capture is complete.

Medium Power draws a normal LED current during image capture which enhances motion tolerance. **Medium Power** attempts to read as long as the trigger is pulled, going into a "doze" (low power) state after each read attempt. The Imager powers down ten seconds after the image capture is complete.

Normal Power draws a normal LED current, attempting to read as long as the trigger is pulled. The Imager doesn't go into a "doze" state after each read attempt, but may power down after two minutes if Power Hold Mode is turned Off.



Low Power



Medium Power



* Normal Power

Power Hold Mode

Power Hold **On** keeps the Imager in a ready to read state. To conserve power, this selection may be turned **Off** and the unit will power down if not used within two minutes. When you are ready to use the Imager again, restore power by pressing the trigger.



On



* Off

LED Power Level

This selection allows you to adjust LED brightness.

Off is used when no illumination is needed. **Low** is used if low illumination is sufficient. **High** (the default) is the brightest setting.



Off



Low



* High

LED Flashing

If LED Flashing is turned off, the average current draw is increased and the aiming light won't illuminate while the scanner reads a bar code.



Off †



* On

† If LED Flashing is turned off, the average current draw is increased and the view finder won't illuminate during the reading phase.

Aimer Delay

The aimer delay allows a delay time for the operator to aim the scanner before the picture is taken. Use these codes to set the time between when the trigger is pulled and when the picture is taken. During the delay time, the aiming light will appear, but the LEDs won't turn on until the delay time is over.



200 milliseconds



400 milliseconds



* Off (no delay)

Aimer Timeout

Use this selection to set a timeout (in seconds) of the Imager's aiming light when the device is not reading a bar code. *Default setting = 60 seconds*



Set Timeout ‡

‡ A one- to three digit number and Save are required after reading this programming symbol. Refer to the Programming Chart (inside back cover).

Aimer Interval

Aimer Interval turns off the aiming light, or programs the aimer to come on at certain intervals when reading symbols with the scanner. You may program the scanner to use the aimer Every Read, Every Second Read, or Every Third Read. You may also program the scanner to use the aimer every “x” reads, by entering a number from 0 to 999 to indicate “x.”



Off



* Every Read



Every Second Read



Every Third Read



Every “x” Reads ‡

‡ A one- to three digit number and Save are required after reading this programming symbol. Refer to the Programming Chart (inside back cover).

AutoTrigger

Two AutoTrigger Modes are available: Scan Stand and Presentation Mode.

When a unit is in Scan Stand mode, the LED shines at the symbol on the base of the stand which tells it to remain idle. When a different code is presented, the Imager is triggered to read the new code.

Presentation mode is for those applications where a scan stand will not work, i.e., when large packages must be scanned. To program the device for presentation mode, refer to "Presentation Mode" on page 2-21.

Scan Stand

This selection programs the Imager to work in a Scan Stand.



* Off



On

Scan Stand LED Intensity

This sets the idle LED intensity when the Imager is in Scan Stand mode. When a unit is in Scan Stand mode, the LED shines at the symbol on the base of the stand which tells it to remain idle. When a different code is presented, the Imager is triggered to read the new code. If the Imager has difficulty going back to reading the Scan Stand's fixed code, for instance, in a low lighting situation, you may want to adjust the Scan Stand LED Intensity. A two digit number between 15 and 75 must be input after the Scan Stand LED Intensity programming code is scanned. A 15 corresponds to the lowest intensity level, and a 75 corresponds to the highest intensity level. 15 is the default setting.

Note that when the unit is triggered to read a code, the unit uses the LED power level specified through "LED Power Level" on page 2-17.



Set Scan Stand LED Intensity

Scan Stand Lights

You can turn off the scanner light when the imager is in idle mode in a scan stand.



Off



* On

Presentation Mode

This programs the scanner to work in Presentation Mode. *Default = Off.*



* Off



On

Presentation Reread Delay

This sets the time period before the scanner can read the *same* bar code a second time. Setting a reread delay protects against accidental rereads of the same bar code. Longer delays are effective in minimizing accidental rereads at POS (point of sale). Use shorter delays in applications where repetitive bar code scanning is required. Entries are in milliseconds, up to 10,000. *Default = 500.*



Presentation Reread Delay

Presentation Default

Defaults all presentation mode settings. *Defaults = Presentation Mode Off, Presentation Reread Delay 500 ms (1/2 sec.), Presentation Aimer On.*



Presentation Default

Presentation Aimer

You can turn on or off the scanner's aiming light when the device is not reading a bar code.



Off



* On

Zoom

Use Zoom to zoom in and read smaller matrix codes. The zoom selection does not affect reading of linear bar codes. The factory default setting is Off. (High Density scanners are programmed with the zoom turned on when shipped from the factory. If you scan the LR Factory Default Settings code on page 2-2, the zoom will be turned off.)



On



* Off

Zoom Placement

This lets you position the read area (crosshairs) of the Imager when it is in zoom mode. The Zoom Vertical moves the crosshairs vertically, and the Zoom Horizontal move them horizontally, as illustrated below:

Note: When zoom is turned on, the field of view of the Imager is reduced, making it more difficult for the Imager to read large matrix symbols.

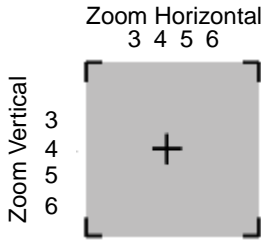

After the Zoom Placement code below is scanned, you must scan a 1 digit code (inside back cover) to enter the zoom position you want. The default for both vertical and horizontal placement is 4, which centers the crosshairs in the field of view.



Zoom Vertical



Zoom Horizontal

Note: The default setting for the HD Imager is a Zoom Vertical of 6 and, for the HD10, the default setting is a Zoom Vertical of 5.

Beeper Volume



Off



Low



Medium



* High

Power Up Beeper



* On



Off

Output Sequence Beeper

If you are using an Output Sequence (see "Output Sequence Overview" on page 2-41), you may want to hear a beep after each bar code as it is read. Scan Output Sequence Beeper On to enable this feature, or Off to disable it.



* On



Off

Beep On Decode

If you want the scanner to beep each time it reads a bar code, leave this setting On. If you don't want it to beep on each read, but do want it to beep for other events, set this selection to Off.



* On



Off

Beeper Default

Defaults all beeper settings. *Defaults = Beeper Volume High, Power Up Beeper On, Output Sequence Beeper On, Beep On Read On.*



Beeper Default

Intercharacter, Interfunction, and Intermessage Delays

Some terminals drop information (characters) if data comes through too quickly. Intercharacter, interfunction, and intermessage delays slow the transmission of data, which increases data integrity.

Each delay is composed of a 5 millisecond step. You can program up to 99 steps (of 5 ms each).

Intercharacter Delay

This is a delay of up to 495 milliseconds (in multiples of 5) placed between the transmission of each character of scanned data. You can program up to 99 steps (of 5 ms each). Scan the Intercharacter Delay bar code below, then scan the number of steps, and the **SAVE** bar code from the inside back cover.

Note: If you make an error while scanning the digits (before scanning Save), scan **Discard** on the back cover and scan the correct digits and **Save** again.

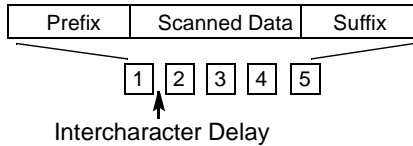

Intercharacter Delay

To remove this delay, scan the Intercharacter Delay bar code, then set the number of steps to 00. Scan the **SAVE** bar code from the inside back cover.

Interfunction Delay

This is a delay of up to 495 milliseconds (in multiples of 5) placed between the transmission of each segment of the message string. You can program up to 99 steps (of 5 ms each). Scan the Interfunction Delay bar code below, then scan the number of steps, and the **SAVE** bar code from the inside back cover.

*Note: If you make an error while scanning the digits (before scanning Save), scan **Discard** on the back cover and scan the correct digits and **Save** again.*

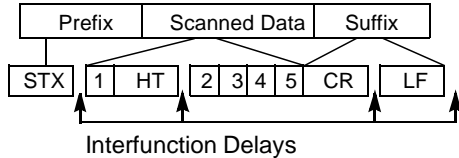

Interfunction Delay

To remove this delay, scan the Interfunction Delay bar code, then set the number of steps to 00. Scan the **SAVE** bar code from the inside back cover.

Intermessage Delay

This is a delay of up to 495 milliseconds (in multiples of 5) placed between each scan transmission. You can program up to 99 steps (of 5 ms each). Scan the Intermessage Delay bar code below, then scan the number of steps, and the **SAVE** bar code from the inside back cover.

Note: If you make an error while scanning the digits (before scanning Save), scan **Discard** on the back cover and scan the correct digits and **Save** again.

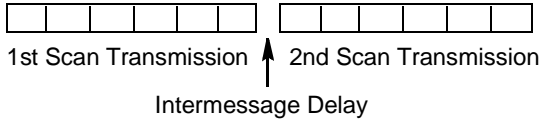

Intermessage Delay

To remove this delay, scan the Intermessage Delay bar code, then set the number of steps to 00. Scan the **SAVE** bar code from the inside back cover.

Prefix/Suffix Overview

When a bar code is scanned, additional information is sent to the host computer along with the bar code data. This group of bar code data and additional, user-defined data is called a "message string." The selections in this section are used to build the user-defined data into the message string.

Prefix and Suffix characters are data characters that can be sent before and after scanned data. You can specify if they should be sent with all symbologies, or only with specific symbologies. The following illustration shows the breakdown of a message string:

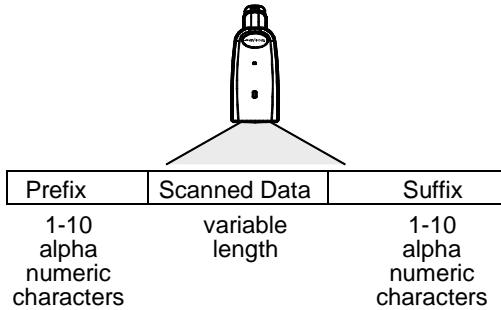

Points to Keep In Mind

- It is not necessary to build a message string. The selections in this chapter are only used if you wish to alter the default settings. *Default prefix = None. Default suffix = None.*
- A prefix or suffix may be added or cleared from one symbology or all symbologies.
- You can add any prefix or suffix from the "Decimal to Hex to ASCII Conversion Chart" on page 2-34, plus Code I.D. and Aim I.D.
- You can string together several entries for several symbologies at one time.
- Enter prefixes and suffixes in the order in which you want them to appear on the output.

Adding a Prefix or Suffix

1. Scan the **Add Prefix** (page 2-32) or **Add Suffix** symbol (page 2-32).
2. Determine the 2 digit Hex value from the "Symbology Chart "on page 2-33 for the symbology to which you want to apply the prefix or suffix.
3. Scan the 2 hex digits from the Programming Chart inside the back cover or scan **9, 9** for all symbologies.
4. Determine the hex value from the "Symbology Chart "on page 2-33 for the prefix or suffix you wish to enter.
5. Scan the 2 digit hex value from the Programming Chart inside the back cover.

Note: Repeat Steps 4 and 5 for every prefix or suffix character.

Note: To add the Code I.D., scan **5, C, 8, 0**.

To add AIM I.D., scan **5, C, 8, 1**.

To add a backslash (\), scan **5, C, 5, C**.

6. Scan **Save** to exit and save, or scan **Discard** to exit without saving.

Repeat Steps 1-6 to add a prefix or suffix for another symbology.

Example: Add a Suffix to a specific symbology

To send a CR (carriage return) Suffix for UPC only:

1. Scan **Add Suffix**.
2. Determine the 2 digit hex value from the "Symbology Chart" on page 2-33 for UPC.
3. Scan **6, 3** from the Programming Chart (inside back cover).
4. Determine the hex value from the "Decimal to Hex to ASCII Conversion Chart" on page 2-34 for the CR (carriage return).
5. Scan **0, D** from the Programming Chart (inside back cover).
6. Scan **Save**, or scan **Discard** to exit without saving.

Clearing One or All Prefixes or Suffixes

You can clear a single prefix or suffix, or clear all prefixes/suffixes for a symbology. When you Clear One Prefix (Suffix), the specific character you select is deleted from the symbology you want. When you Clear All Prefixes (Suffixes), all the prefixes or suffixes for a symbology are deleted.

1. Scan the **Clear One Prefix** or symbol.
2. Determine the 2 digit Hex value from the "Symbology Chart "on page 2-33 for the symbology from which you want to clear the prefix or suffix.
3. Scan the 2 digit hex value from the Programming Chart inside the back cover or scan **9, 9** for all symbologies.

Your change is automatically saved.

Add a Carriage Return Suffix to All Symbologies

Scan the following bar code if you wish to add a Carriage Return Suffix to all symbologies at once. This action first clears all current suffixes, then programs a carriage return suffix for all symbologies.



Add CR Suffix
All Symbologies

Add a Code I.D. Prefix to All Symbologies

This selection allows you to turn on (or off) transmission of a Code I.D. before the decoded symbology. (See the "Symbology Chart" on page 2-33 for the single character code that identifies each symbology.) This action first clears all current prefixes, then programs a Code I.D. prefix for all symbologies.



Add Code ID Prefix
All Symbologies

Add an AIM I.D. Prefix to All Symbologies

This selection allows you to turn on (or off) transmission of an AIM I.D. before the decoded symbology. (See the "Symbology Chart" on page 2-33 for the single character code that identifies each symbology.) This action first clears all current prefixes, then programs an AIM I.D. prefix for all symbologies.



Add AIM ID Prefix
All Symbologies

(See AIM Guidelines on Symbology Identifiers for more information on the AIM symbology ID characters.)

Prefix Entries



Add Prefix †



Clear One Prefix †



Clear All Prefixes

Suffix Entries



Add Suffix †



Clear One Suffix †



Clear All Suffixes

† One or more two digit numbers and Save are required after reading this programming symbol. Refer to the Programming Chart (inside back cover).

Exit Selections



Save



Discard

Symbology Chart

Symbology	Code ID	AIM ID	Hex ID	Symbology	Code ID	AIM ID	Hex ID
Australian 4 State	A	[X	41	Interleaved 2 of 5	e	[I	65
Aztec Code	z	[z	7A	Japanese Postal	J	[X	4A
BC412**	g	[X	67	Kix (Dutch) Postal	K	[X	4B
BPO 4 State	B	[X	42	Maxicode	x	[U	78
Canadian 4 State	C	[X	43	Micro PDF417	R	[L	52
Codabar	a	[F	61	No Read			9C
Codablock-F	q	[O	71	OCR	o	[Y	6F
Code 39	b	[A	62	PDF417	r	[L	72
Code 49	l	[T	6C	Planet Code	L	[X	4C
Code 93/93i	i	[G	69	Postnet	P	[X	50
Code 128	j	[C	6A	QR Code	s	[Q	73
Code Z**	u	[X	75	RSS/Composites	y	[e	79
Data Matrix	w	[d	77	UPC	c	[E	63
EAN	d	[E	64	Vericode**	v	[V	76
lata 2 of 5	f	[R	66	<i>All Symbologies †</i>			99

Note: Prefix/Suffix entries for specific symbologies override the universal (All Symbologies, 99) entry.

† All Symbologies: Prefix/Suffix programming **only!**

** Not available in standard product. Only available when ordered in custom firmware

Decimal to Hex to ASCII Conversion Chart

Dec.	Hex	ASCII	Dec.	Hex	ASCII	Dec.	Hex	ASCII	Dec.	Hex	ASCII
0	00	NUL	32	20	SP	64	40	@	96	60	'
1	01	SOH	33	21	!	65	41	A	97	61	a
2	02	STX	34	22	"	66	42	b	98	62	b
3	03	ETX	35	23	#	67	43	C	99	63	c
4	04	EOT	36	24	\$	68	44	D	100	64	d
5	05	ENQ	37	25	%	69	45	E	101	65	e
6	06	ACK	38	26	&	70	46	F	102	66	f
7	07	BEL	39	27	'	71	47	G	103	67	g
8	08	BS	40	28	(72	48	H	104	68	h
9	09	HT	41	29)	73	49	I	105	69	i
10	0A	LF	42	2A	*	74	4A	J	106	6A	j
11	0B	VT	43	2B	+	75	4B	K	107	6B	k
12	0C	FF	44	2C	,	76	4C	L	108	6C	l
13	0D	CR	45	2D	-	77	4D	M	109	6D	m
14	0E	SO	46	2E	.	78	4E	N	110	6E	n
15	0F	SI	47	2F	/	79	4F	O	111	6F	o
16	10	DLE	48	30	0	80	50	P	112	70	p
17	11	DC1	49	31	1	81	51	Q	113	71	q
18	12	DC2	50	32	2	82	52	R	114	72	r
19	13	DC3	51	33	3	83	53	S	115	73	s
20	14	DC4	52	34	4	84	54	T	116	74	t
21	15	NAK	53	35	5	85	55	U	117	75	u
22	16	SYN	54	36	6	86	56	V	118	76	v
23	17	ETB	55	37	7	87	57	W	119	77	w
24	18	CAN	56	38	8	88	58	X	120	78	x
25	19	EM	57	39	9	89	59	Y	121	79	y
26	1A	SUB	58	3A	:	90	5A	Z	122	7A	z
27	1B	ESC	59	3B	;	91	5B	[123	7B	{
28	1C	FS	60	3C	<	92	5C	\	124	7C	
29	1D	GS	61	3D	=	93	5D]	125	7D	}
30	1E	RS	62	3E	>	94	5E	^	126	7E	~
31	1F	US	63	3F	?	95	5F	_	127	7F	DEL

Data Format Editor Overview

The Data Format Editor selections are used to edit scanned data. For example, you can use the Data Format Editor to insert characters at certain points in bar code data as it is scanned.

It is not necessary to use the Data Format Editor. A set of defaults for the data format is already programmed in the scanner. The selections in the following pages are used only if you wish to alter the default settings. *Default Data Format setting = none.*

If you have changed data format settings, and wish to clear all formats and return to the defaults, scan the **Default Data Format** code.

To Add a Data Format

1. Scan the **Enter Data Format** symbol (page 2-38).
2. **Primary/Alternate Format**
Determine if this will be your primary data format, or one of 3 alternate formats. (Alternate formats allow you "single shot" capability to scan one bar code using a different data format. After the one bar code has been read, the scanner reverts to the primary data format. See "Alternate Data Formats" on page 2-40.) If you are programming the primary format, scan **0**. If you are programming an alternate format, scan **1**, **2**, or **3**, depending on the alternate format you are programming.
3. **Terminal Type**
Refer to the "Supported Terminals Chart" on page 2-5 and locate the Terminal ID number for your PC. Scan three numeric bar codes on the inside back cover to program the scanner for your terminal ID (you must enter **3** digits). For example, scan **0 0 3** for an AT wedge.
4. **Code I.D.**
On page 2-33, find the symbology to which you want to apply the data format. Locate the Hex value for that symbology and scan the 2 digit hex value from the Programming Chart.
5. **Length**
Specify what length (up to 9999 characters) of data will be acceptable for this symbology. Scan the four digit data length from the Programming Chart. (Note: 50 characters is entered as 0050. 9999 is a universal number, indicating all lengths.)
6. **Editor Commands**
Refer to the "Format Editor Commands" on page 2-36. Scan the symbols that represent the command you want to enter. 94 alphanumeric characters may be entered for each symbology data format.
7. Scan **Save** to save your entries.

Other Programming Selections

- **Clear One Data Format**

This deletes one data format for one symbology. If you are clearing the primary format, scan **0**. If you are clearing an alternate format, scan **1**, **2**, or **3**, depending on the alternate format you are clearing. Scan the Terminal Type (refer to the "Supported Terminals Chart" on page 2-5), Code I.D. and the length of the format you want to delete. That length data format for that symbology is deleted and all other formats are unaffected.

- **Save**

This exits, saving any Data Format changes.

- **Discard**

This exits without saving any Data Format changes.

Format Editor Commands

Send Commands

- F1 Send all characters followed by "xx" key or function code, starting from current cursor position. **Syntax = F1xx** (xx stands for the hex value for an ASCII code, see "Decimal to Hex to ASCII Conversion Chart" on page 2-34.)
- F2 Send "nn" characters followed by "xx" key or function code, starting from current cursor position. **Syntax = F2nnxx** (nn stands for the numeric value (00-99) for the number of characters and xx stands for the hex value for an ASCII code. See "Decimal to Hex to ASCII Conversion Chart" on page 2-34.)
- F3 Send up to but not including "ss" character (Search and Send) starting from current cursor position, leaving cursor pointing to "ss" character followed by "xx" key or function code. **Syntax = F3ssxx** (ss and xx both stand for the hex values for ASCII codes, see "Decimal to Hex to ASCII Conversion Chart" on page 2-34.)
- F4 Send "xx" character "nn" times (Insert) leaving cursor in current cursor position. **Syntax = F4xxnn** (xx stands for the hex value for an ASCII code, see "Decimal to Hex to ASCII Conversion Chart" on page 2-34, and nn is the numeric value (00-99) for the number of times it should be sent.)
- E9 Send all but the last "nn" characters, starting from the current cursor position. **Syntax = E9nn** (nn is the numeric value (00-99) for the number of characters that will not be sent at the end of the message.)

Move Commands

- F5 Move the cursor ahead "nn" characters from current cursor position. **Syntax = F5nn** (nn stands for the numeric value (00-99) for the number of characters the cursor should be moved ahead.)
- F6 Move the cursor back "nn" characters from current cursor position. **Syntax = F6nn** (nn stands for the numeric value (00-99) for the number of characters the cursor should be moved back.)
- F7 Move the cursor to the beginning of the data string. **Syntax = F7.**
- EA Move the cursor to the end of the data string. **Syntax = EA**

Search Commands

- F8 Search ahead for "xx" character from current cursor position, leaving cursor pointing to "xx" character. **Syntax = F8xx** (xx stands for the hex value for an ASCII code, see "Decimal to Hex to ASCII Conversion Chart" on page 2-34.)
- F9 Search back for "xx" character from current cursor position, leaving cursor pointing to "xx" character. **Syntax = F9xx** (xx stands for the hex value for an ASCII code, see "Decimal to Hex to ASCII Conversion Chart" on page 2-34.)
- E6 Search ahead for the last instance of "xx" character from the current cursor position, then increment cursor. **Syntax = E6xx** (xx stands for the hex value for an ASCII code, see "Decimal to Hex to ASCII Conversion Chart" on page 2-34.)
- E7 Search back for the last instance of "xx" character from the current cursor position, then increment cursor. **Syntax = E7xx** (xx stands for the hex value for an ASCII code, see "Decimal to Hex to ASCII Conversion Chart" on page 2-34.)

Miscellaneous Commands

- FB Suppress all occurrences of up to 15 different characters, starting at the current cursor position, as the cursor is advanced by other commands. When the FC command is encountered, the suppress function is terminated. The cursor is not moved by the FB command. **Syntax = FBnnxxyy . zz** where nn is a count of the number suppress characters in the list and xxyy .. zz is the list of characters to be suppressed. (xx stands for the hex value for an ASCII code, see "Decimal to Hex to ASCII Conversion Chart" on page 2-34.)
- FC Disable suppress filter and clear all suppressed characters. **Syntax = FC.**
- E4 Replaces up to 15 characters in the data string with user specified characters. Replacement continues until the E5 command is encountered. **Syntax = E4nnxx₁xx₂yy₁yy₂..zz₁zz₂** where nn is the total count of both characters to be replaced plus replacement characters; xx₁ defines characters to be replaced and xx₂ defines replacement characters, continuing through zz₁ and zz₂.
- E5 Terminates character replacement. **Syntax = E5.**
- FE Compare character in current cursor position to the character "xx." If characters are equal, increment cursor. If characters are not equal, no format match. **Syntax = FExx** (xx stands for the hex value for an ASCII code, see "Decimal to Hex to ASCII Conversion Chart" on page 2-34.)
- EC Check to make sure there is a numeric character at the current cursor position. If character is not numeric, format is aborted. **Syntax = EC.**
- ED Check to make sure there is a non-numeric character at the current cursor position. If character is numeric, format is aborted. **Syntax = ED.**

Data Format Editor

See page 2-35 through page 2-37 for a description of Data Format selections and commands.



Enter Data Format †



Default
Data Format
(*none*)



Clear One
Data Format †



Clear All
Data Formats

Exit Selections



Save Current
Data Format Changes



Discard Current
Data Format Changes

† One or more two digit numbers and Save are required after reading this programming symbol. Refer to the Programming Chart (inside back cover).

Data Formatter

When Data Formatter is turned off, the bar code data is output to the host as read (including prefixes and suffixes).



* On



Off

Require Data Format

When Data Formatter is required, all input data must conform to an edited format or the scanner does not transmit the input data to the host device.



Required

Show Data Formats

Read the Show Data Formats bar code to transmit the existing data formats. One format per line is printed out.



Show Data Formats

Alternate Data Formats

Alternate formats allow you “single shot” capability to scan one bar code using a different data format than your primary format. When data formats are programmed (see page 2-35), you must input whether you are programming the primary format, or an alternate format numbered 1, 2, or 3.

An alternate format is initiated by scanning one of the 3 alternate format bar codes below. The scanner will scan the next bar code, formatting the data with the selected alternate format, then revert immediately to the primary format.



Alternate
Data Format 1



Alternate
Data Format 2



Alternate Data Format 3

Output Sequence Overview

Require Output Sequence

When turned off, the bar code data will be output to the host as the Imager decodes it. When turned on, all output data must conform to an edited sequence or the Imager will not transmit the output data to the host device.

Note: This selection is unavailable when the Multiple Symbols Selection is turned on.

Output Sequence Editor

This programming selection allows you to program the Imager to output data (when scanning more than one symbol) in whatever order your application requires. Reading the **Default Sequence** symbol programs the Imager to the Universal values, shown below. These are the defaults. Be **certain** you want to delete or clear all formats before you read the **Default Sequence** symbol.

Note: To make Output Sequence Editor selections, you'll need to know the code I.D., code length, and character match(es) your application requires. Use the Alphanumeric symbols (inside back cover) to read these options.

To Add an Output Sequence

1. Scan the **Enter Sequence** symbol (see "Output Sequence Editor "on page 2-44).
2. **Code I.D.**
On the "Symbology Chart"on page 2-33, find the symbology to which you want to apply the output sequence format. Locate the Hex value for that symbology and scan the 2 digit hex value from the Programming Chart (inside back cover).
3. **Length**
Specify what length (up to 9999 characters) of data output will be acceptable for this symbology. Scan the four digit data length from the Programming Chart. (Note: 50 characters is entered as 0050. 9999 is a universal number, indicating all lengths.)
4. **Character Match Sequences**
On the "Decimal to Hex to ASCII Conversion Chart" on page 2-34, find the Hex value that represents the character(s) you want to match. Use the Programming Chart to read the alphanumeric combination that represents the ASCII characters. (99 is the Universal number, indicating all characters.)
5. **End Output Sequence Editor**
Scan **F F** to enter an Output Sequence for an additional symbology, or **Save Current Sequence Changes** to save your entries.

Other Programming Selections

- **Discard Current Sequence Changes**
This exits without saving any Output Sequence changes.

Output Sequence Example

In this example, you are scanning Codabar, Code 128, and Code 39 bar codes, but you want the scanner to output Code 39 1st, Code 128 2nd, and Codabar 3rd, as shown below.



A - Code 39



B - Code 128

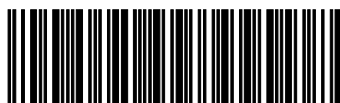

C-123456789B

Note: To use this example, you must turn on Codabar start/stop characters (see page 3-2).

You would set up the sequence editor with the following command line:

SEQBLK62999941FF6A999942FF61999943FF

The breakdown of the command line is shown below:

SEQBLKsequence editor start command

62 code identifier for **Code 39**

9999 code length that must match for Code 39, 9999 = all lengths

41 start character match for Code 39, 41h = "A"

FF termination string for first code

6A code identifier for **Code 128**

9999 code length that must match for Code 128, 9999 = all lengths

42 start character match for Code 128, 42h = "B"

FF termination string for second code

61 code identifier for **Codabar**

9999 code length that must match for Codabar, 9999 = all lengths

43 start character match for Codabar, 43h = "C"

FF termination string for third code

Require Output Sequence

When an output sequence is Required, all output data must conform to an edited sequence or the scanner will not transmit the output data to the host device. When it's On/Not Required, the scanner will attempt to get the output data to conform to an edited sequence, but if it cannot, the scanner transmits all output data to the host device as is.

When the output sequence is Off, the bar code data is output to the host as the scanner decodes it.

Note: This selection is unavailable when the Multiple Symbols Selection is turned on.



Required



On/Not Required



Off

Output Sequence Editor



Enter Sequence †



Default Sequence

Exit Selections



Save Current
Output Sequence Changes



Discard Current
Output Sequence Changes

Note: If you want the scanner to beep after each bar code is read, please see "Output Sequence Beeper" on page 2-24.

† One or more two digit numbers and Save are required after reading this programming symbol. Refer to the Programming Chart (inside back cover).

Multiple Symbols

Note: This feature does not work when the Imager is in Low Power mode.

When this programming selection is turned on, it allows you to read multiple symbols with a single pull of the Imager's trigger. If you press and hold the trigger, aiming the Imager at a series of symbols, it reads unique symbols once, beeping (if turned on) for each read. When this programming selection is turned off, the Imager will only read the symbol closest to the aiming beam.



On



* Off

No Read

With No Read turned on, the Imager notifies you if a code cannot be read. In the Quick*View Scan Data Window (see "Scan Data Window" on page 6-4), an "NR" appears when a code cannot be read. If No Read is turned off, the "NR" will not appear.



On



* Off

If you want a different notation than "NR," for example, "Error," or "Bad Code," you can edit the output message using the Data Formatter (see page 2-35). The hex code for the No Read symbol is 9C.

Print Weight

Print Weight is used to adjust the way the scanner reads Matrix symbols. If a scanner will be seeing consistently heavily printed matrix symbols, then a print weight of 6 may improve the reading performance. For consistently light printing, a print weight of 2 may help. A value from 0 to 8 may be used to adjust the print weight. The default print weight is 4.



† Set Print Weight



* Default

† A one digit number from 0 to 8 is required after reading this programming symbol. Refer to the Programming Chart (inside back cover).

Introduction

Use this section to program the hand-held Imager.

This programming section contains the following menuing selections:

- Linear Symbology Selections
- Stacked Symbology Selections
- Postal Symbology Selections
- 2D Matrix Symbology Selections
- Diagnostics

Linear Symbologies

Codabar

<Default All Codabar Settings>



Codabar



* On



Off

Start/Stop Characters

Start/Stop characters identify the leading and trailing ends of the bar code. You may either transmit, or not transmit Start/Stop characters.



Start/Stop Transmit



* Don't Transmit
Start/Stop

Message Length

The message length selection is used to set the valid reading length of the bar code. If the data length of the scanned bar code doesn't match the valid reading length, the scanner will issue an error beep. You may wish to set the same value for minimum and maximum length to force the scanner to read fixed length bar code data. This helps reduce the chances of a misread.

EXAMPLE: Decode only those bar codes with a count of 9-20 characters.

Min. length = 09 Max. length = 20

EXAMPLE: Decode only those bar codes with a count of 15 characters.

Min. length = 15 Max. length = 15



Minimum
Message Length



Maximum
Message Length

A one- to two-digit number and Save are required after reading this programming symbol. Refer to the Programming Chart (inside back cover).

Linear Symbologies

Codabar, continued

Check Character

No Check Character indicates that the scanner reads and transmits bar code data with or without a check character.

When Check Character is set to Validate, But Don't Transmit, the unit will only read Codabar bar codes printed **with** a check character, but will not transmit the check character with the scanned data.

When Check Character is set to Validate, And Transmit, the scanner will only read Codabar bar codes printed with a check character, and will transmit this character at the end of the scanned data.



* No Check Character



Validate,
But Don't Transmit



Validate,
And Transmit

Linear Symbologies

Code 39

< Default All Code 39 Settings >



Code 39



* On



Off

Start/Stop Characters

Start/Stop characters identify the leading and trailing ends of the bar code. You may either transmit, or not transmit Start/Stop characters.



Transmit



* Don't Transmit

Message Length

The message length selection is used to set the valid reading length of the bar code. If the data length of the scanned bar code doesn't match the valid reading length, the scanner will issue an error beep. You may wish to set the same value for minimum and maximum length to force the scanner to read fixed length bar code data. This helps reduce the chances of a misread.

EXAMPLE: Decode only those bar codes with a count of 9-20 characters.

Min. length = 09 Max. length = 20

EXAMPLE: Decode only those bar codes with a count of 15 characters.

Min. length = 15 Max. length = 15



Minimum
Message Length



Maximum
Message Length

A one- to two-digit number and Save are required after reading this programming symbol. Refer to the Programming Chart (inside back cover).

Linear Symbolgies

Code 39, continued

Full ASCII

If Full ASCII Code 39 decoding is turned on, certain character pairs within the bar code symbol will be interpreted as a single character. For example: \$V will be decoded as the ASCII character SYN, and /C will be decoded as the ASCII character #.

NUL %U	DLE \$P	SP SPACE	0 0	@ %V	P P	' W	p +P	
SOH \$A	DC1 \$Q	! /A	1 1	A A	Q Q	a +A	q +Q	
STX \$B	DC2 \$R	" /B	2 2	B B	R R	b +B	r +R	
ETX \$C	DC3 \$S	# /C	3 3	C C	S S	c +C	s +S	
EOT \$D	DC4 \$T	\$ /D	4 4	D D	T T	d +D	t +T	
ENQ \$E	NAK \$U	% /E	5 5	E E	U U	e +E	u +U	
ACK \$F	SYN \$V	& /F	6 6	F F	V V	f +F	v +V	
BEL \$G	ETB \$W	' /G	7 7	G G	W W	g +G	w +W	
BS \$H	CAN \$X	(/H	8 8	H H	X X	h +H	x +X	
HT \$I	EM \$Y) /I	9 9	I I	Y Y	i +I	y +Y	
LF \$J	SUB \$Z	* /J	:	/Z	J J	Z Z	j +J	z +Z
VT \$K	ESC %A	+ /K	;	%F	K K	[%K	k +K	{ %P
FF \$L	FS %B	, /L	<	%G	L L	\ %L	l +L	%Q
CR \$M	GS %C	- -	=	%H	M M] %M	m +M	} %R
SO \$N	RS %D	. .	>	%I	N N	^ %N	n +N	~ %S
SI \$O	US %E	/ /O	?	%J	O O	_ %O	o +O	DEL %T

Character pairs /M and /N decode as a minus sign and period respectively.
Character pairs /P through /Y decode as 0 through 9.



Full ASCII On



* Full ASCII Off

Linear Symbologies

Code 39, continued

Check Character

No Check Character indicates that the scanner reads and transmits bar code data with or without a check character.

When Check Character is set to Validate, But Don't Transmit, the unit will only read Code 39 bar codes printed **with** a check character, but will not transmit the check character with the scanned data.

When Check Character is set to Validate, And Transmit, the scanner will only read Code 39 bar codes printed with a check character, and will transmit this character at the end of the scanned data. will transmit this character at the end of the scanned data.



* No Check Character



Validate,
But Don't Transmit



Validate,
And Transmit

Linear Symbolologies

Interleaved 2 of 5

< Default All Interleaved 2 of 5 Settings >



Interleaved 2 of 5



* On



Off

Message Length

The message length selection is used to set the valid reading length of the bar code. If the data length of the scanned bar code doesn't match the valid reading length, the scanner will issue an error beep. You may wish to set the same value for minimum and maximum length to force the scanner to read fixed length bar code data. This helps reduce the chances of a misread.

EXAMPLE: Decode only those bar codes with a count of 9-20 characters.

Min. length = 09 Max. length = 20

EXAMPLE: Decode only those bar codes with a count of 15 characters.

Min. length = 15 Max. length = 15



Minimum
Message Length



Maximum
Message Length

A one- to two-digit number and Save are required after reading this programming symbol. Refer to the Programming Chart (inside back cover).

Linear Symbologies

Interleaved 2 of 5, continued

Check Digit

When Check Digit is set to Validate, But Don't Transmit, the unit will only read Interleaved 2 of 5 bar codes printed **with** a check digit, but will not transmit the check digit with the scanned data.

When Check Digit is set to Validate, And Transmit, the scanner will only read Interleaved 2 of 5 bar codes printed with a check digit, and will transmit this digit at the end of the scanned data.



* No Check Digit



Validate,
But Don't Transmit



Validate,
And Transmit

Linear Symbologies

Iata 2 of 5

< Default All Iata 2 of 5 Settings >



Iata 2 of 5



* On



Off

Message Length

The message length selection is used to set the valid reading length of the bar code. If the data length of the scanned bar code doesn't match the valid reading length, the scanner will issue an error beep. You may wish to set the same value for minimum and maximum length to force the scanner to read fixed length bar code data. This helps reduce the chances of a misread.

EXAMPLE: Decode only those bar codes with a count of 9-20 characters.

Min. length = 09 Max. length = 20

EXAMPLE: Decode only those bar codes with a count of 15 characters.

Min. length = 15 Max. length = 15



Minimum
Message Length



Maximum
Message Length

A one- to two-digit number and Save are required after reading this programming symbol. Refer to the Programming Chart (inside back cover).

Linear Symbologies

Code 93

< Default All Code 93 Settings >



Code 93



* On



Off

Message Length

The message length selection is used to set the valid reading length of the bar code. If the data length of the scanned bar code doesn't match the valid reading length, the scanner will issue an error beep. You may wish to set the same value for minimum and maximum length to force the scanner to read fixed length bar code data. This helps reduce the chances of a misread.

EXAMPLE: Decode only those bar codes with a count of 9-20 characters.
Min. length = 09 Max. length = 20

EXAMPLE: Decode only those bar codes with a count of 15 characters.
Min. length = 15 Max. length = 15



Minimum
Message Length



Maximum
Message Length

A one- to two-digit number and Save are required after reading this programming symbol. Refer to the Programming Chart (inside back cover).

Linear Symbolologies

Code 128

< Default All Code 128 Settings >



Code 128



* On



Off

Message Length

The message length selection is used to set the valid reading length of the bar code. If the data length of the scanned bar code doesn't match the valid reading length, the scanner will issue an error beep. You may wish to set the same value for minimum and maximum length to force the scanner to read fixed length bar code data. This helps reduce the chances of a misread.

EXAMPLE: Decode only those bar codes with a count of 9-20 characters.

Min. length = 09

Max. length = 20

EXAMPLE: Decode only those bar codes with a count of 15 characters.

Min. length = 15

Max. length = 15



Minimum
Message Length



Maximum
Message Length

A one- to two-digit number and Save are required after reading this programming symbol. Refer to the Programming Chart (inside back cover).

Linear Symbologies

ISBT

Scan the On code below if you wish to decode ISBT bar codes. (ISBT codes are a combination of multiple linear symbols used to mark blood bags.)



On



* Off

Linear Symbologies

EAN/JAN 8

< Default All EAN/JAN 8 Settings >



EAN/JAN 8



* On



Off

Check Digit

This selection allows you to specify whether the check digit should be transmitted at the end of the scanned data or not.



Transmit
Check Digit



* Don't Transmit
Check Digit

Linear Symbologies

EAN/JAN 13

< Default all EAN/JAN 13 Settings >



EAN/JAN 13



* On



Off

Check Digit

This selection allows you to specify whether the check digit should be transmitted at the end of the scanned data or not.



Transmit
Check Digit



* Don't Transmit
Check Digit

Linear Symbolologies

EAN Addenda

You can add 2 or 5 digits to the end of all scanned EAN data (EAN 8 and EAN 13).



2 Digit Addenda On



* 2 Digit
Addenda Off



5 Digit Addenda On



* 5 Digit
Addenda Off

Linear Symbologies

UPC A

< Default All UPC A Settings >



UPC A



* On



Off

Check Digit

This selection allows you to specify whether the check digit should be transmitted at the end of the scanned data or not.



Transmit
Check Digit



* Don't Transmit
Check Digit

Number System

The numeric system digit of a UPC symbol is normally transmitted, but the unit can be programmed so it will not transmit it.



* Transmit
Number System



Don't Transmit
Number System

Linear Symbolologies

UPC E0

< Default All UPC E0 Settings >



UPC E0

Most UPC bar codes lead with the 0 number system. For these codes, use the UPC E0 selection. If you need to read codes which lead with the 1 number system, use the UPC E1 selection.



* On



Off

Check Digit

This selection allows you to specify whether the check digit should be transmitted at the end of the scanned data or not.



Transmit
Check Digit



* Don't Transmit
Check Digit

Number System

The numeric system digit of a UPC symbol is normally transmitted, but the unit can be programmed so it will not transmit it.



Transmit
Number System



* Don't Transmit
Number System

Linear Symbologies

UPC E0, continued

Version E Expand

Version E Expand, expands the UPC-E code to the 12 digit, UPC-A format.



Expand



* Don't Expand

UPC E1

Most UPC bar codes lead with the 0 number system. For these codes, use the UPC E0 selection. If you need to read codes which lead with the 1 number system, use the UPC E1 selection.



* On



Off

UPC Addenda

You can add 2 or 5 digits to the end of all scanned UPC data (UPC A, UPC E0, and UPC E1).



2 Digit
Addenda On



* 2 Digit
Addenda Off



5 Digit
Addenda On



* 5 Digit
Addenda Off

Linear Symbologies

RSS-14

< Default All RSS-14 Settings >



RSS-14

Reduced Space Symbology (RSS) is a family of linear bar codes which meets restricted space requirements, while still providing full product identification.



* RSS-14 On



RSS-14 Off

RSS-14 Limited

< Default All RSS-14 Limited Settings >



RSS-14 Limited



* RSS-14 Limited On



RSS-14 Limited Off

Linear Symbologies

RSS-14 Expanded

< Default All RSS-14 Expanded Settings >



RSS-14 Expanded



* RSS Expanded On



RSS Expanded Off

Message Length

The message length selection is used to set the valid reading length of the bar code. If the data length of the scanned bar code doesn't match the valid reading length, the scanner will issue an error beep. You may wish to set the same value for minimum and maximum length to force the scanner to read fixed length bar code data. This helps reduce the chances of a misread.

EXAMPLE: Decode only those bar codes with a count of 9-20 characters.

Min. length = 09 Max. length = 20

EXAMPLE: Decode only those bar codes with a count of 15 characters.

Min. length = 15 Max. length = 15



Minimum
Message Length



Maximum
Message Length

A one- to two-digit number and Save are required after reading this programming symbol. Refer to the Programming Chart (inside back cover).

Stacked Symbolologies

Codablock

< Default All Codablock Settings >



Codablock



On



* Off

Message Length

The message length selection is used to set the valid reading length of the bar code. If the data length of the scanned bar code doesn't match the valid reading length, the scanner will issue an error beep. You may wish to set the same value for minimum and maximum length to force the scanner to read fixed length bar code data. This helps reduce the chances of a misread.

EXAMPLE: Decode only those bar codes with a count of 9-20 characters.

Min. length = 09 Max. length = 20

EXAMPLE: Decode only those bar codes with a count of 15 characters.

Min. length = 15 Max. length = 15



Minimum
Message Length



Maximum
Message Length

A one- to two-digit number and Save are required after reading this programming symbol. Refer to the Programming Chart (inside back cover).

Stacked Symbologies

PDF417

< Default All PDF417 Settings >



PDF417



* On



Off

Message Length

The message length selection is used to set the valid reading length of the bar code. If the data length of the scanned bar code doesn't match the valid reading length, the scanner will issue an error beep. You may wish to set the same value for minimum and maximum length to force the scanner to read fixed length bar code data. This helps reduce the chances of a misread.

EXAMPLE: Decode only those bar codes with a count of 9-20 characters.
Min. length = 09 Max. length = 20

EXAMPLE: Decode only those bar codes with a count of 15 characters.
Min. length = 15 Max. length = 15



Minimum
Message Length



Maximum
Message Length

A one- to two-digit number and Save are required after reading this programming symbol. Refer to the Programming Chart (inside back cover).

Stacked Symbolologies

Micro PDF417

< Default All Micro PDF417 Settings >



Micro PDF417



On



* Off

Message Length

The message length selection is used to set the valid reading length of the bar code. If the data length of the scanned bar code doesn't match the valid reading length, the scanner will issue an error beep. You may wish to set the same value for minimum and maximum length to force the scanner to read fixed length bar code data. This helps reduce the chances of a misread.

EXAMPLE: Decode only those bar codes with a count of 9-20 characters.

Min. length = 09

Max. length = 20

EXAMPLE: Decode only those bar codes with a count of 15 characters.

Min. length = 15

Max. length = 15



Minimum
Message Length



Maximum
Message Length

A one- to two-digit number and Save are required after reading this programming symbol. Refer to the Programming Chart (inside back cover).

Stacked Symbologies

Code 49

< Default All Code 49 Settings >



Code 49



On



* Off

Message Length

The message length selection is used to set the valid reading length of the bar code. If the data length of the scanned bar code doesn't match the valid reading length, the scanner will issue an error beep. You may wish to set the same value for minimum and maximum length to force the scanner to read fixed length bar code data. This helps reduce the chances of a misread.

EXAMPLE: Decode only those bar codes with a count of 9-20 characters.

Min. length = 09 Max. length = 20

EXAMPLE: Decode only those bar codes with a count of 15 characters.

Min. length = 15 Max. length = 15



Minimum
Message Length



Maximum
Message Length

A one- to two-digit number and Save are required after reading this programming symbol. Refer to the Programming Chart (inside back cover).

Stacked Symbolologies

Composite Codes

Linear codes are combined with a unique 2D composite component to form a new class called Composite symbology. Composite symbologies allow for the co-existence of symbologies already in use.



* On



Off

Message Length

The message length selection is used to set the valid reading length of the bar code. If the data length of the scanned bar code doesn't match the valid reading length, the scanner will issue an error beep. You may wish to set the same value for minimum and maximum length to force the scanner to read fixed length bar code data. This helps reduce the chances of a misread.

EXAMPLE: Decode only those bar codes with a count of 9-20 characters.

Min. length = 09

Max. length = 20

EXAMPLE: Decode only those bar codes with a count of 15 characters.

Min. length = 15

Max. length = 15



Minimum
Message Length



Maximum
Message Length

A one- to two-digit number and Save are required after reading this programming symbol. Refer to the Programming Chart (inside back cover).

Postal Symbologies

U.S. Postal Service POSTNET Code



On



* Off

Planet Code



On



* Off

British Post Office 4 State Code



On



* Off

Canadian 4 State Code



On



* Off

Dutch Postal Code



On



* Off

Postal Symbologies

Australian 4 State Code

Note: Australian 4 State Code symbology is not available in the standard IMAGETEAM 4400/4700 products, and may only be ordered by licensed users as a custom 6-digit part number.



On



* Off

Japanese Postal Service



On



* Off

2D Matrix Symbologies

QR Code

< Default All QR Code Settings >



QR Code



* On



Off

Message Length

The message length selection is used to set the valid reading length of the bar code. If the data length of the scanned bar code doesn't match the valid reading length, the scanner will issue an error beep. You may wish to set the same value for minimum and maximum length to force the scanner to read fixed length bar code data. This helps reduce the chances of a misread.

EXAMPLE: Decode only those bar codes with a count of 9-20 characters.
Min. length = 09 Max. length = 20

EXAMPLE: Decode only those bar codes with a count of 15 characters.
Min. length = 15 Max. length = 15



Minimum
Message Length



Maximum
Message Length

A one- to two-digit number and Save are required after reading this programming symbol. Refer to the Programming Chart (inside back cover).

2D Matrix Symbolologies

Data Matrix

< Default All Data Matrix Settings >



Data Matrix



* On



Off

Message Length

The message length selection is used to set the valid reading length of the bar code. If the data length of the scanned bar code doesn't match the valid reading length, the scanner will issue an error beep. You may wish to set the same value for minimum and maximum length to force the scanner to read fixed length bar code data. This helps reduce the chances of a misread.

EXAMPLE: Decode only those bar codes with a count of 9-20 characters.

Min. length = 09 Max. length = 20

EXAMPLE: Decode only those bar codes with a count of 15 characters.

Min. length = 15 Max. length = 15



Minimum
Message Length



Maximum
Message Length

A one- to two-digit number and Save are required after reading this programming symbol. Refer to the Programming Chart (inside back cover).

2D Matrix Symbologies

MaxiCode

< Default All MaxiCode Settings >



MaxiCode



* On



Off

Message Length

The message length selection is used to set the valid reading length of the bar code. If the data length of the scanned bar code doesn't match the valid reading length, the scanner will issue an error beep. You may wish to set the same value for minimum and maximum length to force the scanner to read fixed length bar code data. This helps reduce the chances of a misread.

EXAMPLE: Decode only those bar codes with a count of 9-20 characters.
Min. length = 09 Max. length = 20

EXAMPLE: Decode only those bar codes with a count of 15 characters.
Min. length = 15 Max. length = 15



Minimum
Message Length



Maximum
Message Length

A one- to two-digit number and Save are required after reading this programming symbol. Refer to the Programming Chart (inside back cover).

2D Matrix Symbologies

MaxiCode, continued

Structured Carrier Message Only

A MaxiCode is made up of a primary and secondary message. The primary portion, also known as the “structured carrier message,” contains information of primary importance, such as package destination. The secondary portion contains less important data, such as package weight. If your application requires only the primary data from MaxiCodes, turn Structured Carrier Message Only on. Turn this feature on if you are trying to read a damaged Maxicode. The scanner may be able to extract just the structured carrier message if the center portion of the code is intact.



On



* Off

2D Matrix Symbologies

Aztec Code

< Default All Aztec Code Settings >



Aztec Code



* On



Off

Message Length

The message length selection is used to set the valid reading length of the bar code. If the data length of the scanned bar code doesn't match the valid reading length, the scanner will issue an error beep. You may wish to set the same value for minimum and maximum length to force the scanner to read fixed length bar code data. This helps reduce the chances of a misread.

EXAMPLE: Decode only those bar codes with a count of 9-20 characters.
Min. length = 09 Max. length = 20

EXAMPLE: Decode only those bar codes with a count of 15 characters.
Min. length = 15 Max. length = 15



Minimum
Message Length



Maximum
Message Length

A one- to two-digit number and Save are required after reading this programming symbol. Refer to the Programming Chart (inside back cover).

2D Matrix Symbologies

VeriCode

Note: VeriCode is a proprietary symbology, licensed to its users by Veritec, Inc. This symbology is not available in standard IMAGETEAM 4400/4700 products and may only be ordered by licensed users as a custom 6-digit part number.

< Default All VeriCode Settings >



VeriCode



* On



Off

2D Matrix Symbologies

VeriCode, continued

VeriCode Size

This selection allows you to program the Imager to read fixed VeriCode symbol sizes. If your application requires that the Imager read one fixed size, scan one of the Size menu symbols and the size (from 10 to 48, even numbers only). The size you set will be the only one turned on. If you need more sizes turned on (up to 3), scan another Size menu symbol and the required size(s). *Default = 0 or Off (all sizes turned on).*



Size A



Size B



Size C



Size D



Size E

A one- to two-digit number and Save are required after reading this programming symbol. Refer to the Programming Chart (inside back cover).

Diagnostics

Test Menu

When you scan the Test Menu code then scan a programming code in this manual, the scanner displays the content of a programming code. The programming function will still occur, but in addition, the content of that programming code is output to the terminal. You may wish to use this feature in conjunction with Quick*View (see page 6-1).



On



* Off

2D Scan Diagnostics

When turned on, 2D Scan Diagnostics display information about symbologies as codes are scanned. Your terminal displays the diagnostic information first, then the data from the scanned code.



On



* Off

The following list shows the information that appears for each type of symbology.

Note: The higher the percentage of unused error correction (UEC), the easier it should be to read each code.

Aztec Code: x layers, xx data & xx chks in GF(xxx), EUC = xxx%

Layers = Aztec properties

Data = Number of data words

Chks = Number of check words

UEC = Unused Error Correction

PDF 417: x rows, x cols, xx data & xx chks (ECL = x), EUC = xxx%

Rows = Number of rows

Cols = Number of columns

Data = Number of data words

Chks = Number of check words

ECL = Error Correction Level

UEC = Unused Error Correction

Data Matrix: ECC xxx, 20 x 20, UEC = xxx%

ECC = Error Checking and Correction

20 x 20 = Symbol size in modules

UEC = Unused Error Correction

Diagnostics

2D Scan Diagnostics, continued

MaxiCode: Mode x, UEC = xxx%

Mode x = Code structure definition

UEC = Unused Error Correction

Micro PDF 417: x rows, x cols, xx data & xx chks, EUC = xxx%

Rows = Number of rows

Cols = Number of columns

Data = Number of data words

Chks = Number of check words

EUC = Unused Error Correction

QR Code: Model x, Version x, ECL x, Mask x, EUC = xxx%

Model = Code capacity specification

Version = Code structure definition

ECL = Error Correction Level

Mask = Mask pattern specification

EUC = Unused Error Correction

Introduction

Use this section to program the hand-held Imager to read machine readable fonts used in optical character recognition (OCR). The IT4400 reads 6 to 60 point OCR typeface

The IT4400/4700 will read the following fonts:

- OCR-A
0123456789ABCDEFGHI JKLMNOPQRSTUVWXYZ
() < > / \ + - * \$
- OCR-B
0123456789ABCDEFGHI JKLMNOPQRSTUVWXYZ
() < > / \ + - * \$
- U.S. Currency Serial Number (Money)
I 07700277 **F**
*

You can either select an OCR default, or create your own custom template for the type of OCR format you intend to read. See "OCR" on page 4-2 for programming codes that will enable your scanner to read OCR-A, OCR-B or U.S. Currency fonts. See "Creating OCR Templates" on page 4-3 if you want to create a custom "template," or character string that defines the length and content of OCR strings that will be read with your scanner.

OCR

Default All OCR Settings turns off all OCR capability in the scanner, so the scanner will be able to scan linear, stacked, matrix, and composite bar codes, but not OCR fonts. In addition, any OCR templates you have created are erased. The 8 digit default templates are reinstated for any future use of the **OCR On** codes listed below.

< *Default All OCR Settings* >



OCR

OCR-A On allows you to scan characters in the OCR-A font. The default setting allows you to scan any 8 digit combination. If you have created an OCR template, character combinations that fit the template can be scanned (see "Creating an OCR Template" on page 4-3).



OCR-A On

OCR-B On allows you to scan characters in the OCR-B font. The default setting allows you to scan any 8 digit combination. If you have created an OCR template, character combinations that fit the template can be scanned (see "Creating an OCR Template" on page 4-3).



OCR-B On

U.S. Currency On allows you to scan characters in the font used on U.S. currency. The default setting allows you to scan any 8 digit combination. If you have created an OCR template, character combinations that fit the template can be scanned (see "Creating an OCR Template" on page 4-3).



U.S. Currency On

All OCR Off turns off all OCR capability in the scanner, so the scanner will be able to scan linear, stacked, matrix, and composite bar codes, but not OCR fonts. However, any OCR templates you have created will be retained in memory.



* All OCR Off

Creating OCR Templates

You can create a custom “template,” or character string that defines the length and content of OCR strings that will be read with your scanner. There are several choices when creating a custom template for your application. You can create a template for a single format, you can string together several formats, and you can create a template for a user-defined variable. These choices are described in detail below.

Creating an OCR Template

A single template allows you to program the scanner to read any combination of characters in the order you specify.

Template Characters

a	represents any alphanumeric character (digit or letter)
c	represents a check character position
d	represents any digit
e	represents any available OCR character
g	represents user-defined variable
h	represents user-defined variable
l	represents any uppercase letter
t	marks the start of a new template
All other characters represent themselves. Spaces can be used.	

To Add an OCR Template

1. Begin building the template.
Scan the **Enter OCR Template** symbol (page 4-7).
2. Scan the characters for the string.
Use the Template Characters chart above to determine what characters you need to create your format. Use the Programming Chart (inside back cover) to scan the characters for your template.

Example A: You need to read any combination of 8 digits. The template:

dddddddd

To create this template, you would scan the **Enter OCR Template** symbol (page 4-7), then scan the “d” from the inside back cover 8 times. Scan **Save OCR Template** (page 4-8). This would let you read any string of 8 digits, for example:

37680981

3. Character Match Sequences
On the "Decimal to Hex to ASCII Conversion Chart" on page 2-34, find the Hex value that represents the character(s) you want to match. Use the Programming Chart (inside back cover) to scan the numbers that represent these characters.

Example B: You need to read 3 digits, 3 specific characters (ABC), 3 digits. The template:

ddd414243ddd

hex codes for
letters A, B, and C

To create this template, you would scan the **Enter OCR Template** symbol (page 4-7), scan the “d” from the inside back cover 3 times, scan **414243** from the inside back cover (the hex characters for “A,” “B,” and “C”), then scan the “d” from the inside back cover 3 more times. Scan **Save OCR Template** (page 4-8). This would let you read any string of 3 digits, “ABC,” then any string of 3 digits, for example:

551ABC983

4. Adding Spaces

You may also need to put spaces in your template.

Example C: You need to read 3 digits, space, 3 specific characters (ABC), space, 3 digits. The template:

ddd2041424320ddd
 ↓ ↓
 hex code for a space

To create this template, you would scan the **Enter OCR Template** symbol (page 4-7), scan the “d” from the inside back cover 3 times, scan **2041424320** from the inside back cover (the hex characters for “space,” “A,” “B,” “C,” “space”), then scan the “d” from the inside back cover 3 more times. Scan **Save OCR Template** (page 4-8). This would let you read any string of 3 digits, space, “ABC,” space, then any string of 3 digits, for example:

551 ABC 983

5. Exit OCR Template Editor

Scan **Save OCR Template** to save your entries. **Discard OCR Template** exits without saving any OCR Template changes.

Stringing Together Multiple Formats (Creating “Or” Statements)

You may want to program the scanner to accept many OCR formats. To do this, you would string together each format with a “t.” This tells the scanner to read optical characters that match any one of the formats in the template.

Example D: You need to read any combination of 8 digits, or a combination of 4 digits, 2 uppercase letters, and 2 digits. The template:

dddddddtddddlldd

To create this template, you would scan the **Enter OCR Template** symbol (page 4-7), scan the “d” from the inside back cover 8 times, then scan the “t” to create the “or” statement. Then you would scan the characters for the 2nd template. Scan the “d” 4 times, scan “l” 2 times, then scan “d” 2 more times. Scan **Save OCR Template** (page 4-8). This would let you read either type of format, for example:

99028650
 or
9902XZ50

You can string together as many templates as you need.

Creating a User-Defined Variable

You can create up to two of your own user variables for an OCR template. These variables will represent any OCR readable characters. The user-defined variables are stored under the letters "g" and "h." Creating a user variable follows the same steps as creating a template, but instead of scanning the **Enter OCR Template** symbol, you scan the **Enter User-Defined Variable** symbol (page 4-7). The letters g and h can then be used in an OCR template to define the variable you specified.

Example E: You need a variable to represent the letters "A," "B," or "C." The template for this variable:

414243

To create this template, you would scan the **Enter User-Defined Variable "g"** symbol (page 4-7). Scan **414243** from the inside back cover (the hex characters for "A," "B," and "C"). Scan **Save OCR Template** (page 4-8). This will let you read either A or B or C in any position where you place the g. For example, you could create the following template:

ddddddggg

This template would then let you read data that began with 6 digits, and had an A, B, or C trailing. So you would be able to read:

654321ABC
or
654321BAC
or
654321CCC

Adding an OCR Check Character

You may want to program the scanner to read OCR strings that have a check character. The IT4400/4700 reads and strips out the OCR check character created using a modulo 10 or modulo 36 table. (Modulo 10 being digits 0-9, modulo 36 being digits 0-9 and characters A-Z.)

Scan the **Modulo 10** or **Modulo 36 Check Character** bar code to specify the type of check character used in the OCR strings you're scanning. The scanner will then only read OCR character strings with a valid check character. The IT4400/4700 transmits the OCR data without the check character data. You must specify the location of the check character in the template with a **c**.

Example F: You need to read any combination of 6 digits, with a modulo 10 check character in the 7th position. The template:

dddddc

To create this template, you would scan the **Modulo 10 Check Character** symbol (page 4-7). Then scan the **Enter OCR Template** symbol, scan the “d” from the inside back cover 6 times, and scan the “c” once. Scan **Save OCR Template** (page 4-8). This template will let you read any combination of 6 digits with a correct check character after. (If the check character is invalid, the scanner will issue an error beep.) For example, the following string could be scanned:

0123455

and the output would be:012345

OCR Template Codes



Enter OCR Template †



Enter User-Defined Variable
“g”



Enter User-Defined Variable
“h”



OCR Modulo 10
Check
Character



OCR Modulo 36
Check
Character

† One or more two-digit numbers and Save are required after reading this programming symbol. Refer to the Programming Chart (inside back cover).

Exit Selections



Save OCR Template



Discard OCR Template

Default Charts

The following chart lists the factory default settings (indicated by a “★” on the programming menu pages).

Parameter	Default Setting	Page
Terminal ID	003	page 2-4
Keyboard Country	0	page 2-6
Keyboard Style	Regular	page 2-7
Keyboard Modifiers	Control + ASCII Off	page 2-8
	Turbo Mode Off	page 2-8
	Numeric Keypad Off	page 2-8
	Auto Direct Connect Off	page 2-8
<i>Communication (RS-232) Selections</i>		
Parity	None	page 2-11
Baud Rate	38400	page 2-12
Word Length Data Bits	8	page 2-13
Word Length Stop Bits	1	page 2-13
Hardware Flow Control	Off	page 2-14
Software Flow Control	Off	page 2-14
Serial Triggering	On = 18, Off = 20	page 2-15
<i>Imager Selections</i>		
Power Saving Mode	Normal Power	page 2-16
Power Hold Mode	Off	page 2-16
LED Power Level	High	page 2-17
LED Flashing	On	page 2-17
Aimer Delay	Off (no delay)	page 2-18
Aimer Timeout	60 seconds	page 2-18

Parameter	Default Setting	Page
Aimer Interval	Every Read	page 2-19
Scan Stand	Off	page 2-20
Scan Stand LED Intensity	15	page 2-20
Scan Stand Lights	Off	page 2-21
Presentation Mode	Off	page 2-21
Presentation Reread Delay	500 ms	page 2-21
Presentation Aimer	On	page 2-22
Zoom	Off - LR and XLR	page 2-22
Zoom Placement	Horiz 4, Vert 4	page 2-23
Beeper Volume	High	page 2-24
Power Up Beeper	On	page 2-24
Output Sequence Beeper	On	page 2-24
Beep On Decode	On	page 2-25
Intercharacter Delay	0	page 2-26
Interfunction Delay	0	page 2-27
Intermessage Delay	0	page 2-28
<i>Prefix/Suffix Selections</i>		
Prefix	None	page 2-32
Suffix	None	page 2-32
<i>Data Formatter Selections</i>		
Data Format	None	page 2-38
Data Formatter	On	page 2-39
Require Data Format	Not Required	page 2-39
<i>Output Sequence Selections</i>		
Multiple Symbols	Off	page 2-45

Parameter	Default Setting	Page
Require Output Sequence	Don't Require	page 2-43
No Read	Off	page 2-45
Print Weight	4	page 2-46
<i>Linear Symbologies</i>		
Codabar	On	page 3-2
Start/Stop Characters	Don't Transmit	page 3-2
Message Length	Min = 2, Max = 60	page 3-2
Check Character	No Check Character	page 3-3
Code 39	On	page 3-4
Start/Stop Characters	Don't Transmit	page 3-4
Message Length	Min = 0, Max = 48	page 3-4
Full ASCII	Off	page 3-5
Check Character	No Check Character	page 3-6
Interleaved 2 of 5	On	page 3-7
Message Length	Min = 4, Max = 80	page 3-7
Check Digit	No Check Character	page 3-8
lata 2 of 5	On	page 3-9
Message Length	Min = 4, Max = 80	page 3-9
Code 93	On	page 3-10
Message Length	Min = 0, Max = 80	page 3-10
Code 128	On	page 3-11
Message Length	Min = 0, Max = 80	page 3-11
ISBT	Off	page 3-12
EAN/JAN 8	On	page 3-13
Check Digit	Don't Transmit	page 3-13

Parameter	Default Setting	Page
EAN/JAN 13	On	page 3-14
Check Digit	Don't Transmit	page 3-14
UPC A	On	page 3-16
Check Digit	Don't Transmit	page 3-16
Number System	Transmit	page 3-16
UPC E0	On	page 3-17
Check Digit	Don't Transmit	page 3-17
Number System	Don't Transmit	page 3-17
Version E Expand	Don't Expand	page 3-18
UPC E1	On	page 3-18
UPC 2 Digit Addenda	Off	page 3-18
UPC 5 Digit Addenda	Off	page 3-18
RSS-14	On	page 3-19
RSS-14 Limited	On	page 3-19
RSS-14 Expanded	On	page 3-20
RSS-14 Expanded Message Length	Min = 1, Max = 80	page 3-20
Codablock	Off	page 3-21
Message Length	Min = 0, Max = 2048	page 3-21
PDF417	On	page 3-22
Message Length	Min = 1, Max = 2750	page 3-22
Micro PDF417	Off	page 3-23
Message Length	Min = 1, Max = 2750	page 3-23
Code 49	Off	page 3-24
Message Length	Min = 1, Max = 81	page 3-24

Parameter	Default Setting	Page
Composite Codes	On	page 3-25
Message Length	Min = 1, Max = 300	page 3-25
<i>Postal Symbology Selections</i>		
POSTNET Code (USPS)	Off	page 3-26
BPO 4 State Code	Off	page 3-26
Canadian 4 State Code	Off	page 3-26
Kix Code	Off	page 3-26
Australian 4 State Code	Off	page 3-27
Japanese Postal Service	Off	page 3-27
Planet Code	Off	page 3-27
<i>2D Matrix Selections</i>		
QR Code	On	page 3-28
Message Length	Min = 1, Max = 3500	page 3-28
Data Matrix	On	page 3-29
Message Length	Min = 1, Max = 1500	page 3-29
MaxiCode	On	page 3-30
Message Length	Min = 1, Max = 150	page 3-30
SCM Only	Off	page 3-31
Aztec Code	On	page 3-32
Message Length	Min = 1, Max = 3750	page 3-32
VeriCode	On	page 3-33
VeriCode Size	0 or Off (all sizes on)	page 3-34



Quick*View Demonstration Software Instructions

Quick*View is a Microsoft Windows® program that displays decoded symbol messages and captures images (for instance, ID photographs) from the IMAGETEAM 4400/4700 Imager. Bar code information and images are displayed in the Quick*View window.

Setting Up the Imager and the Quick*View Software

1. Connect the Imager to the PC's com port (com port 1 or com port 2) via the appropriate interface cable. Connect the appropriate power supply to the Imager. (The Imager cannot get its power from the PC's com port.)

For Microsoft Windows 95 or NT 4.0

2. Insert the Quick*View diskette labelled "32 Bit Release" into Drive A or B.
3. From the Start Menu, click on Run. Type "x:\setup" in the command line box, where "x" represents a drive letter, typically "A" for the 3.5" floppy drive on most PCs. Click on OK.
4. Follow the instructions in the setup screens.
5. To start the Quick*View program, from the Start Menu click on Programs, Quickview, QuickView (32 Bit).

For Microsoft Windows 3.1

2. Insert the Quick*View diskette labelled "16 Bit Release" into Drive A or B.
3. Copy the QV16.EXE file to your PC hard drive.
4. From the Program Manager, File Menu, Run the QV16.EXE file.

*Installing Quick*View from the Web*

1. Access the Welch Allyn DCD web site at <http://dcd.welchallyn.com>.
2. Click on the **Support** button, then click on the **Software Download** button.
3. When prompted, enter the user name: **pumpkin** and the password: **pie**
4. Locate the listing for **Quick*View**. Click on the yellow **Download** button.
5. When prompted, select **Save File**, and save the files to the **c:\windows\temp** directory.
6. Once you have finished downloading the file, exit the web site.
7. Using Explorer, go to the **c:\windows\temp** file.
8. Double click on the **Quickview.exe** file. Follow the screen prompts to install the Quick*View program.
9. To start Quick*View, from the Start Menu click on **Programs, Quick*View, Quick*View**.

*Note: If you wish, you can create a shortcut to the Quick*View executable on your desktop.*

*Temporary Quick*Load Configuration*

For a quick download communication configuration, scan the Quick*Load bar code and the scanner will be temporarily configured for Quick*Load settings.

*Note: If you have a unit capable of keyboard wedge mode, scan the bar code below and the unit will communicate in RS-232 mode, allowing it to work with Quick*Load. To convert the scanner back to keyboard wedge communication, cycle the power.*



Quick*Load

Using the Quick*View Software

Upon startup, the Quick*View splash screen appears for approximately three seconds. Quick*View will then attempt to establish communications with the Imager.

If Communication Cannot Be Established

This message appears if communication cannot be established:

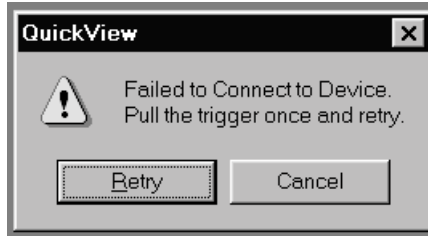

Quick*View defaults to com 1 as the communications port. If you have plugged the Imager into another com port, you must Cancel out of this message.

Click on **File - Preferences**. This popup appears:

Click on the radio button for the appropriate com port, then click on **OK**. Quick*View should now be able to locate the Imager.

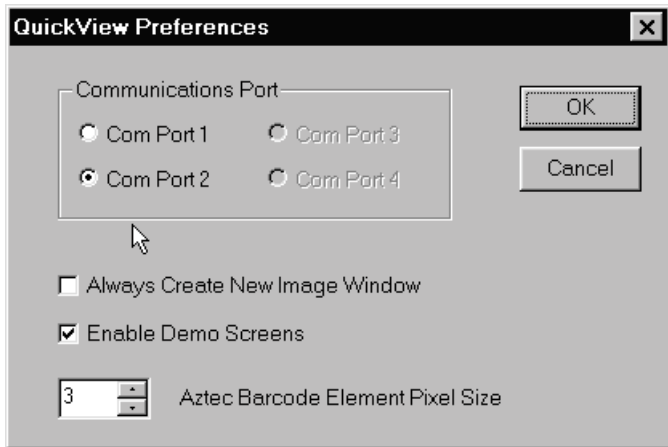

You may also need to pull the Imager's trigger to establish communications between the PC and the Imager.

If you want Quick*View to search for the Imager and establish communication, click on **Device - Auto Baud Detect**.

Scan Data Window

Once successful communication has been established, you can scan codes and display the bar code data in a window. Select **View - Scan Data Window**.



As you scan bar codes, the data appears in the Serial Scan Data Window.

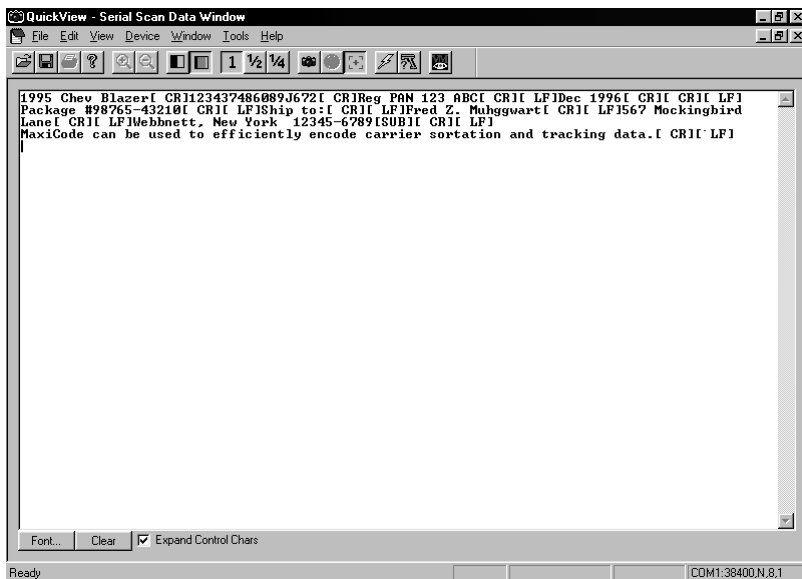

You can alter the font in this window by using the **Font** button, or clear all data in the window with the **Clear** button.

If you wish to see the mnemonic for any embedded control characters, you should put a check in the checkbox for **Expand Control Chars** (the default setting). If you wish to see the ASCII control character rather than the mnemonic, turn off this checkbox.

Note: The ASCII control character which is displayed is dependent on the font you are using.

Demo Screens

To present a demo, you must set your **File - Preferences** to **Enable Demo Screens**.

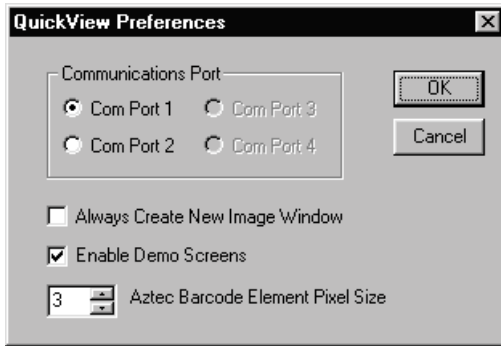

Once the demo screens are enabled, scan the demo bar codes on the following pages. To disable the demo screens, click on the checkbox to remove the checkmark.

Electronic Parts Manufacturing Demonstration

The manufacturing industry represents the fastest growing market for high capacity bar codes by recognizing the long term benefits associated with having complete information on a product at all times. In this demonstration, high capacity codes are used to issue parts to a manufacturing floor. By using a high capacity code, complete information about the parts ensures that the right parts are issued and billed to the proper location. Welch Allyn offers both long-range and high-density models of the IMAGETEAM 4400 to provide the optimal hand held solution for a wide variety of manufacturing operations.

Scan each of the following bar codes to display sample screens for a manufacturing application.

Data Matrix Codes

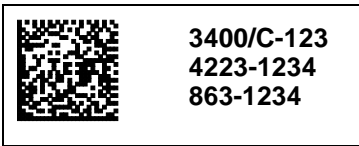

QR Codes



Shipping Demonstration

Note: This demonstration is appropriate for the 4400LR and 4700LR or only.

In an effort to reduce costs through distribution center automation, United Parcel Service (UPS) is printing a MaxiCode label on every package shipped worldwide. In this demonstration, the IMAGETEAM 4400 Imager provides a cost-effective solution for UPS personnel in hand sorting operations, and for customers who want to take advantage of the savings associated with MaxiCode without incurring the cost of an over-the-belt scanning solution.

Scan each of the following bar codes to display sample screens for a shipping application.

Welch Allyn
4619 Jordan Road
Skaneateles Falls, NY 13153

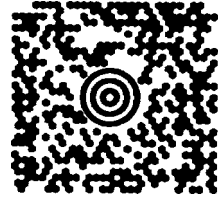

Ship To:

Benjamin F. Lynn
Musket Co.
243 Liberty Parkway
Boston, MA 02134

Benjamin F. Lynn
Musket Co.
243 Liberty Parkway
Boston, MA 02134

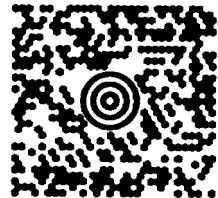

Ship To:

Cheryl Isom
Welch Allyn
4341 Jordan Road, Box 187
Skaneateles Falls, NY 13153

Patient Registration Demonstration

Health care professionals can use two-dimensional symbologies for patient applications. In this demonstration, patient registration information is encoded on an identification card that is scanned each time the patient arrives for treatment. Both the health care professional and the patient benefit from the enhanced accuracy, efficiency, and security that photo identification provides.

Scan each of the following bar codes to display sample screens for this type of patient application.



Patient ID:890-66-4589

Mason, Theresa F.
5 Beach Front Drive
Pensacola, FL 49607





Patient ID:123-45-4569

Ely, Gerald S.
5 Quarry Rd.
Omaha, NE 12345



Bills of Lading Demonstration

Note: This demonstration is appropriate for the 4400LR and 4700LR only.

Multiple linear bar codes may be replaced in a bill of lading/inventory application. In this demonstration, an individual linear code would typically be used for each part number, description, and quantity, as well as for customer and order number information. If linear codes were used for the bill of lading shown below, the user would have to scan 14 individual bar codes before moving on to the next package.

Order #: 99999	Welch Allyn 4619 Jordan Road Box 187 Skaneateles Falls, NY 13153 (315) 685-8945	
Ship to:	ABC Company 123 Highway West San Diego, CA 92100	
Customer #: 1234567890		
Pick Date: March 4, 1998		
<u>Part Number</u>	<u>Description</u>	<u>Quantity</u>
3000-12C	3000PDF	3
6720/B	SCANNER	4
54/57/UG	54/57/UG	3
42204062	CABLE	1

By taking advantage of the enhanced data capacity of PDF417, the user is able to encode all the required information in a single bar code label. Using the Imager and a two-dimensional symbology, the user gets complete information in a single scan.



Scan this bar code to display a sample screen for this bill of lading application.



Signature Capture Demonstration

Note: This demonstration is appropriate for the 4400LR and 4700LR only.

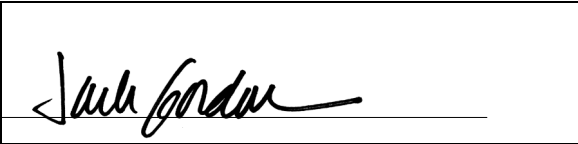
The signature capture demo is performed by scanning the Aztec bar code below the signature box. The Aztec bar code commands the scanner to capture the image of the signature box and its contents and send this image to the host system running Quick*View.

PAUL'S QUICK MART MAIN ST. NEW YORK, NEW YORK 315-123-4567 1122-3344-5678	
THU, MAR 04, 1999 09=34B	
*** CREDIT CARD ***	
CARD NO:	00234567899876543
EXP DATE:	0100
CARD TYPE:	MC - CREDIT
TR TYPE:	SALE
APP CODE:	004910
REC NO:	C009
TOTAL:	\$37.99
Sign	
	

Snapshot

You may also use the IMAGETEAM 4400/4700 to capture an image. Click on **Device - Snapshot**, or click on the camera icon in the button bar to activate this feature.

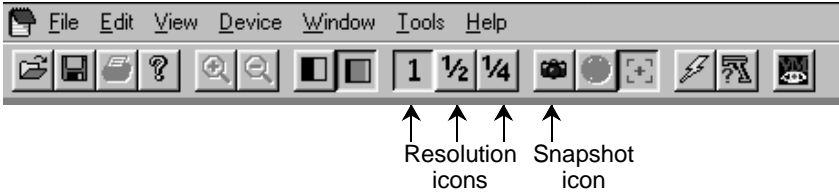

Select the resolution you wish to use for this image, either Full, Half or Quarter Resolution. (These can also be selected by clicking on the 1, 1/2, or 1/4 buttons in the button bar.)

Note: The higher resolution, the sharper the image, and the larger the size of the resulting file. Higher resolution images also take longer to process.

You must also select whether you wish to capture the image in **Gray Scale** or in **Black & White**.

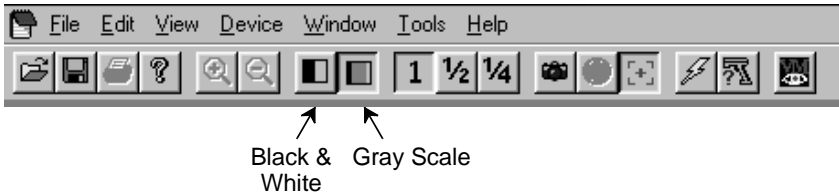

*Note: If you need to see exactly what the Imager sees (for example, if you are diagnosing a bar code), you should set the image to **Black & White**.*

If you want the Imager to display illuminated aiming brackets, click on **Device - Snapshot Properties - Use Aimer During Image Capture**, or click on the aimer icon in the button bar.



Snapshot, continued

Pull the Imager's trigger to capture an image. Captured images appear in the Quick*View window.

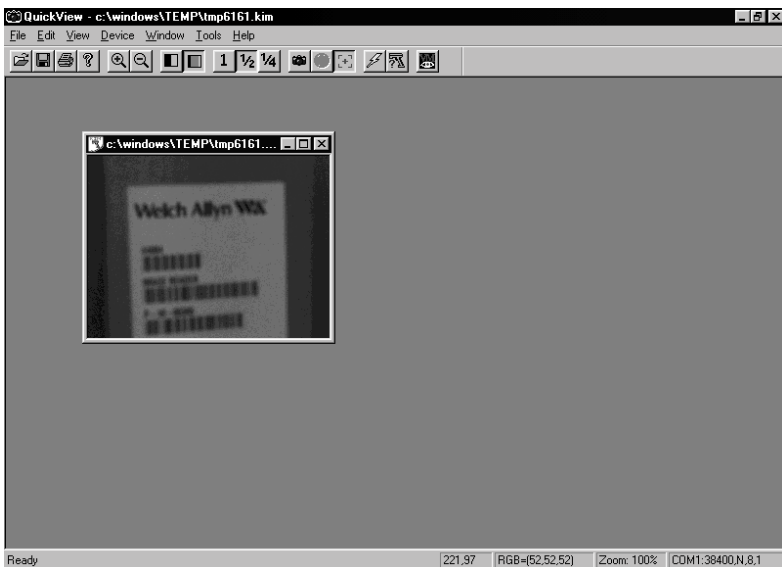

As you move the mouse over the image, the cursor changes to a magnifying glass. Left click to zoom in to the image, right click to zoom out.

Saving an Image File

If you wish to save the file as a bitmap, click on **File - Save As**. Enter the location and file name you wish to use for this file. Click on **Save** and a bitmap file will be saved.

Open Com Port

If you wish to open a com port which does *not* have a device attached, you can do so by selecting **File - Open Com Port**.

This dialog box appears:

Click on the arrows to select the Baud Rate, Parity, and Data Bits for the com port you wish to open. Click on Open Port and Quick*View opens the com port whether or not there is a device attached. This feature may be beneficial when troubleshooting a device.

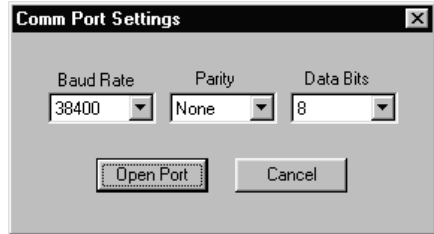

Reporting Firmware Revision

To find out what software version the Imager is using, click on **Device - Report Device Firmware Revision**, or click on the Imager icon in the button bar.



↑
Imager
icon

This popup lists the firmware information:

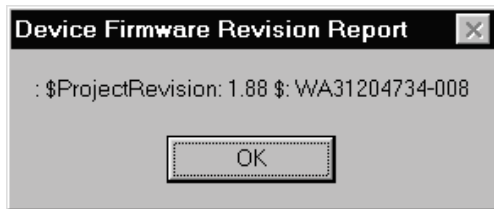

Load New Imager Software

If you need to upgrade the Imager's software, you can load a new software file into the Imager's ROM. Click on **Device - Load Firmware File into ROM** or click on the lightning flash icon in the button bar.



You will be prompted for the name of the hex file:

Select the hex file and click on Open. Quick*View will flash the new software into your Imager's ROM.

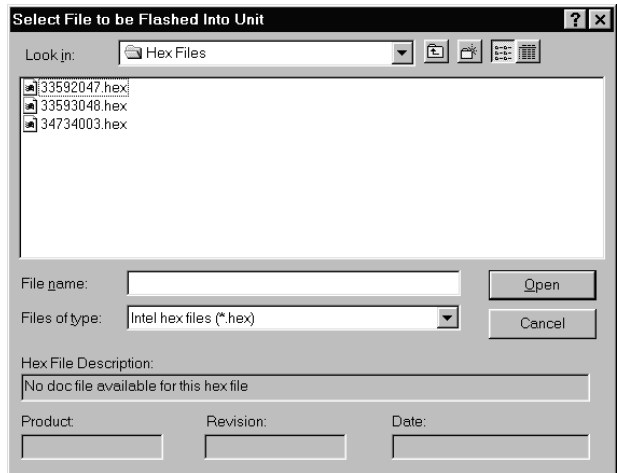

Imager Power Settings

By default, the Imager will power down after 2 minutes of inactivity. If you wish to keep the Imager powered up indefinitely, click on **Device - Hold Power**. To reset the Imager to the default power setting, click on **Device - Remove Power Hold**.

Trigger Settings

If you wish to control the Imager's trigger with the software, you can select **Device - Trigger On**, or **Device - Trigger Off**. These settings turn the trigger on and off just as if you were holding the trigger or releasing it manually. This feature may be necessary when working with a fixed device that has no trigger.

RS-232 Serial Commands

Click on **View - Serial Command Window** to display the Command Center window which allows you to enter serial commands to the Imager. Click on **View - Scan Data Window** to open a window which displays serial data in a text format.

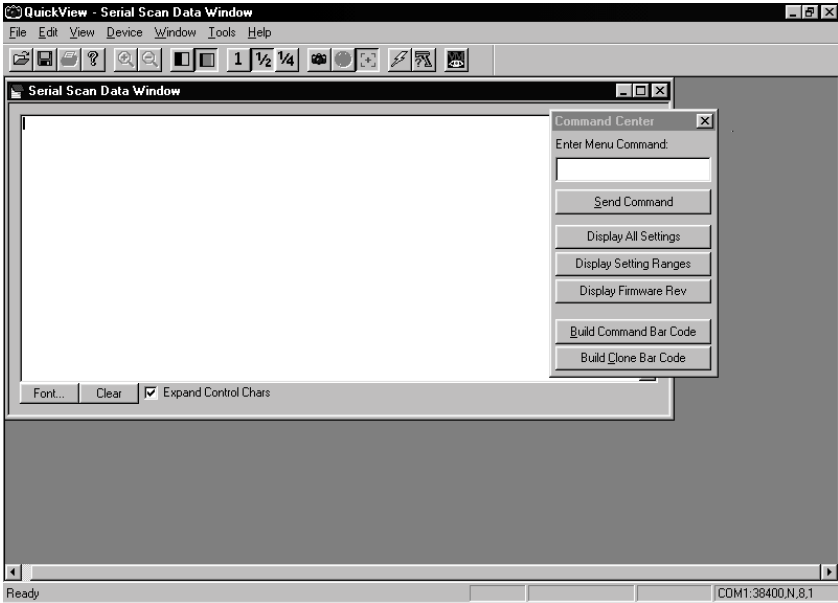

Serial commands are used to program the Imager and to query the Imager about programming parameters. The serial programming commands are listed beginning on page 6-17. Information about performing queries is listed on page 6-28.

Serial Programming Commands

The serial programming commands can be used in place of the programming bar codes listed in Section 2. Both the serial commands and the programming bar codes will program the Imager. For complete descriptions and examples of each programming command, refer to Section 2.

To enter a serial command, click in the **Enter Menu Command** text box and type in the command(s) you wish to use. If you are typing in more than one command, separate the commands with a semicolon (;). Click on **Send Command** to send the command(s) to the Imager.

Responses

The Imager responds to serial commands with one of three responses:

ACK Indicates a good command which has been processed.

ENQ Indicates a bad command.

NAK Indicates the command was good, but the entry was out of the allowable range, e.g., an entry for a minimum message length of 100 when the field will only accept 2 characters.

Command Center Buttons

Display All Settings displays the settings currently saved for the Imager.

Display Setting Ranges displays all the possible serial commands and the allowable data field parameters.

Display Firmware Rev displays the software version being used by the Imager.

Build Command Bar Code is used to create an Aztec code from a command or set of commands entered in the Serial Window. (The size of the Aztec code can be altered using the **File - Preferences** selection.) This bar code can then be printed out and used to program other Imagers.

Build Clone Bar Code is used to capture the settings from one Imager, and input them to another Imager. When the Build Clone Bar Code button is clicked, Quick*View captures the settings from the attached Imager and creates an Aztec code which can be printed. (The size of the Aztec code can be altered using the **File - Preferences** selection.) Any Imager that scans the resulting clone bar code will be programmed to the same settings as the original Imager.

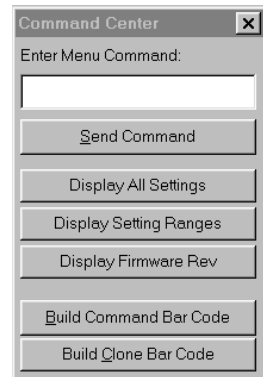

Serial Programming Commands

Selection	Setting	Serial Command
Factory Default Settings	HD	DEFAULT;MXZOOM1.
	HD10	DEFAULT;MXZOOM1; MXZTOP6.
	LR/XLR	DEFAULT.
Status Check		
Show Software Revision		REV?.
Show Data Formats		DFMBK3?.
Enable All Symbologies		ALLENA1.
Disable All Symbologies		ALLENA0.
Output Selections		
Power PC Revision		REVMPC.
Boot Code Revision		REV_BT.
Terminal ID		TERMID.
Keyboard Country		KBDCTY.
Keyboard Style	Regular	KBDSTY0.
	Caps Lock	KBDSTY1.
	Shift Lock	KBDSTY2.
	Emulate External Keyboard	KBDSTY5.
	Automatic Caps Lock	KBDSTY6.
Keyboard Modifiers	*Control + ASCII Off	KBDCAS0.
	Control + ASCII On	KBDCAS1.
	*Turbo Mode Off	KBDTMD0.
	Turbo Mode On	KBDTMD1.
	*Numeric Keypad Off	KBDNPS0.
	Numeric Keypad On	KBDNPS1.
	*Auto Direct Conn. Off	KBDADC0.
	Auto Direct Conn. On	KBDADC1.

Selection	Setting	Serial Command
<i>Communication Settings</i>		
*Default All RS-232 Communication Settings		232DFT.
Parity	*None	232PARN.
	Mark	232PARM.
	Space	232PARS.
	Odd	232PARO.
	Even	232PARE.
Baud Rate	*38400 BPS	232BDR38400.
	300 BPS	232BDR300.
	600 BPS	232BDR600.
	1200 BPS	232BDR1200.
	2400 BPS	232BDR2400.
	4800 BPS	232BDR4800.
	9600 BPS	232BDR9600.
	19200 BPS	232BDR19200.
	57600 BPS	232BDR57600.
115200 BPS	232BDR115200.	
Word Length Data Bits	*8 Data Bits	232LEN8.
	7 Data Bits	232LEN7.
Word Length Stop Bits	*1 Stop Bit	232STP1.
	2 Stop Bits	232STP2.
Hardware Flow Control	*Disable	232CTS0.
	Enable	232CTS1.
Software Flow Control	*Disable	232SFL0.
	Enable	232SFL1.
Serial Triggering	*Disable	TRGSER0.
	Enable	TRGSER1.
	*Trigger Defaults	TRGDFT.
	Trigger On	TRG_ON.
	Trigger Off	TRGOFF.

Selection	Setting	Serial Command
<i>Imager Selections</i>		
Power Saving Mode	*Normal Power	PWRDFT; SCNLEDHIGH; HSTSSS0.
	Low Power	PWRTIM0,TRG0, IMG1;SCNLEDLOW; HSTSSS1.
	Medium Power	PWRTIM10000, TRG0,IMG1; SCNLEDHIGH; HSTSSS0.
Power Hold Mode	On	PWR_ON1.
	*Off	PWR_ON0.
LED Power	*High	SCNLEDHIGH.
	Off	SCNLEDOFF.
	Low	SCNLEDLOW.
LED Flashing	*On	HSTLED0.
	Off	HSTLED1.
Aimer Delay	*Off (no delay)	HSTAIM0.
	200 milliseconds	HSTAIM200.
	400 milliseconds	HSTAIM400.
Aimer Timeout	Set Timeout	HSTTIM.
Aimer Interval	*Every Read	HSTINT1.
	Every 2nd Read	HSTINT2.
	Every 3rd Read	HSTINT3.
	Every "x" Read	HSTINT.
	Off	HSTINT0.
Scan Stand	*Off	SSTMOD0.
	On	SSTMOD1.
Scan Stand LED Intensity	15	SSTFRQ.
Scan Stand Lights	On	SSTLON1.
	*Off	SSTLON0.
Presentation Mode	On	PRSMOD1.
	*Off	PRSMOD0.
Presentation Reread Delay	500 ms	PRSTIM.
Presentation Default		PRSDFT.

Selection	Setting	Serial Command
Presentation Aimer	*On	PRSAIM1.
	Off	PRSAIM0.
Zoom	Disable	MXZOOM0.
	Enable	MXZOOM1.
Zoom Placement	Vertical	MXZTOP.
	Horizontal	MXZSID.
<i>Output Selections</i>		
Beeper Volume	*High	BEPVOL50.
	Medium	BEPVOL25.
	Low	BEPVOL5.
	Off	BEPVOL0.
Power Up Beeper	*Enable	BEPRST1.
	Disable	BEPRST0.
Output Sequence Beeper	*On	BEPCLK1.
	Off	BEPCLK0.
Beep On Decode	*On	BEPDEC1.
	Off	BEPDEC0.
Beeper Default		BEPDFT.
Intercharacter Delay		DLYCHR.
User Specified Intercharacter Delay	Character	DLY_XX.
	Length	DLYCRX.
Interfunction Delay		DLYFNC.
Intermessage Delay		DLYMSG.
<i>Prefix/Suffix Selections</i>		
Add CR Suffix to All Symbologies		SUFBK299CR.
Add Code I.D. Prefix to All Symbologies		PREBK2995C80.
Add AIM I.D. Prefix to All Symbologies		PREBK2995C81.
Prefix	Add Prefix	PREBK2.
	Clear One Prefix	PRECL2.
	Clear All Prefixes	PRECA2.
Save Current Prefix Changes		MNUSAV.
Discard Current Prefix Changes		MNUABT.
Suffix	Add Suffix	SUFBK2.
	Clear One Suffix	SUFCL2.
	Clear All Suffixes	SUFCA2.

Selection	Setting	Serial Command
Save Current Suffix Changes		MNUSAV.
Discard Current Suffix Changes		MNUABT.
<i>Data Formatter Selections</i>		
Data Format Editor	*No Format	DFMDF3.
	Enter Format	DFMBK3.
	Clear One Format	DFMCL3.
	Clear All Formats	DFMCA3.
Save Current Data Format Changes		MNUSAV.
Discard Current Data Format Changes		MNUABT.
Data Formatter	*Enable	DFM_EN1.
	Disable	DFM_EN0.
Require Data Format	Require	DFM_EN2.
Show Data Formats		DFMBK3?.
Alternate Data Formats	1	VSAF_1.
	2	VSAF_2.
	3	VSAF_3.
<i>Output Sequence Selections</i>		
Require Output Sequence	Require	SEQ_EN2.
	On/Not Required	SEQ_EN1.
	Off	SEQ_EN0.
Output Sequence Editor	*Default Sequence	SEQDFT.
	Enter Sequence	SEQBLK.
Save Current Sequence Changes		MNUSAV.
Discard Current Sequence Changes		MNUABT.
Multiple Symbols	*Disable	SEQ_EN0.
	Enable	SEQ_EN1.
No Read	*Disable	SHWNRD0.
	Enable	SHWNRD1.
Print Weight	Default	PRTWGT4.
Set Print Weight		PRTWGT.
<i>Linear Symbology Selections</i>		
Codabar	*Default All Codabar Settings*	CBRDFT.
Codabar	*On	CBRENA1.
	Off	CBRENA0.

Selection	Setting	Serial Command
Codabar Start/Stop Char.	*Don't Transmit	CBRSSX0.
	Transmit	CBRSSX1.
Codabar Message Length	Minimum	CBRMIN.
	Maximum	CBRMAX.
Codabar Check Char.	*No Check Char.	CBRCHK0,CKX0.
	Validate, But Don't Transmit	CBRCHK1,CKX0.
	Validate, and Transmit	CBRCHK1,CKX1.
Code 39	*Default All Code 39 Settings*	C39DFT.
Code 39	*On	C39ENA1.
	Off	C39ENA0.
Code 39 Start/Stop Char.	*Don't Transmit	C39SSX0.
	Transmit	C39SSX1.
Code 39 Full ASCII	*Disable	C39ASC0.
	Enable	C39ASC1.
Code 39 Message Length	Minimum	C39MIN.
	Maximum	C39MAX.
Code 39 Check Char.	*No Check Char.	C39CHK0,CKX0.
	Validate, But Don't Transmit	C39CHK1,CKX0.
	Validate, and Transmit	C39CHK1,CKX1.
Interleaved 2 of 5	*Default All Interleaved 2 of 5 Settings*	I25DFT.
Interleaved 2 of 5	*On	I25ENA1.
	Off	I25ENA0.
Interleaved 2 of 5 Message Length	Minimum	I25MIN.
	Maximum	I25MAX.
Interleaved 2 of 5 Check Digit	*No Check Char.	I25CHK0,CKX0.
	Validate, But Don't Transmit	I25CHK1,CKX0.
	Validate, and Transmit	I25CHK1,CKX1.
lata 2 of 5	*Default All Iata 2 of 5 Settings*	A25DFT.

Selection	Setting	Serial Command
lata 2 of 5	*On	A25ENA1.
	Off	A25ENA0.
lata 2 of 5 Message Length	Minimum	A25MIN.
	Maximum	A25MAX.
Code 93	*Default All Code 93 Settings*	C93DFT.
Code 93	*On	C93ENA1.
	Off	C93ENA0.
Code 93 Message Length	Minimum	C93MIN.
	Maximum	C93MAX.
Code 128	*Default All Code 128 Settings*	128DFT.
Code 128	*On	128ENA1.
	Off	128ENA0.
Code 128 Message Length	Minimum	128MIN.
	Maximum	128MAX.
Code 128 Include	*Disable	128FNC0.
Code 128 ISBT	*Disable	ISBENA0.
	Enable	ISBENA1.
EAN/JAN 8	*Default All EAN/JAN 8 Settings*	EA8DFT.
EAN/JAN 8	*On	EA8ENA1.
	Off	EA8ENA0.
EAN/JAN 8 Check Digit	*Don't Transmit	EA8CKX0.
	Transmit	EA8CKX1.
EAN/JAN 13	*Default All EAN/JAN 13 Settings*	E13DFT.
EAN/JAN 13	*On	E13ENA1.
	Off	E13ENA0.
EAN/JAN 13 Check Digit	*Don't Transmit	E13CKX0.
	Transmit	E13CKX1.
EAN/JAN 2 Digit Addenda	On	EANAD21.
	Off	EANAD20.
EAN/JAN 5 Digit Addenda	On	EANAD51.
	Off	EANAD50.
UPC A	*Default All UPC A Settings*	UPADFT.

Selection	Setting	Serial Command
UPC A	*On	UPAENA1.
	Off	UPAENA0.
UPC A Check Digit	*Don't Transmit	UPACKX0.
	Transmit	UPACKX1.
UPC A Number System	Don't Transmit	UPANSX0.
	*Transmit	UPANSX1.
UPC E0	*Default All UPC E0 Settings*	UE0DFT.
UPC E0	*On	UE0ENA1.
	Off	UE0ENA0.
UPC E0 Check Digit	*Don't Transmit	UE0CKX0.
	Transmit	UE0CKX1.
UPC E0 Number System	*Don't Transmit	UE0NSX0.
	Transmit	UE0NSX1.
UPC E0 Version E Expand	*Don't Expand	UE0EXP0.
	Expand	UE0EXP1.
UPC E1	*On	UE1ENA1.
	Off	UE1ENA0.
UPC 2 Digit Addenda	On	UPCAD21.
	Off	UPCAD20.
UPC 5 Digit Addenda	On	UPCAD51.
	Off	UPCAD50.
RSS-14	*Default All RSS-14 Settings*	RSSDFT.
RSS-14	*On	RSSENA1.
	Off	RSSENA0.
RSS-14 Limited	*Default All RSS-14 Limited Settings*	RSLDFT.
RSS-14 Limited	*On	RSLENA1.
	Off	RSLENA0.
RSS-14 Limited	*Default All RSS-14 Expanded Settings*	RSEDFT.
RSS Expanded	*On	RSEENA1.
	Off	RSEENA0.
RSS Expanded Msg. Length	Minimum	RSEMIN.
	Maximum	RSEMAX.

Selection	Setting	Serial Command
<i>Stacked Symbology Selections</i>		
Codablock	*Default All Codablock Settings*	CBFDFT.
Codablock	On	CBFENA1.
	*Off	CBFENA0.
Codablock Msg. Length	Minimum	CBFMIN.
	Maximum	CBFMAX.
PDF417	*Default All PDF417 Settings*	PDFDFT.
PDF417	*On	PDFENA1.
	Off	PDFENA0.
PDF417 Message Length	Minimum	PDFMIN.
	Maximum	PDFMAX.
Micro PDF417	*Default All Micro PDF Settings*	MPDDFT.
Micro PDF417	On	MPDENA1.
	*Off	MPDENA0.
Micro PDF417 Message Length	Minimum	MPDMIN.
	Maximum	MPDMAX.
Code 49	*Default All Code 49 Settings*	C49DFT.
Code 49	On	C49ENA1.
	*Off	C49ENA0.
Code 49 Msg. Length	Minimum	C49MIN.
	Maximum	C49MAX.
Composite Codes	*On	COMENA1.
	Off	COMENA0.
Composite Msg. Length	Minimum	COMMEN.
	Maximum	COMMAX.
<i>Postal Symbology Selections</i>		
POSTNET Code (USPS)	*On	NETENA1.
	Off	NETENA0.
POSTNET Check Digit	*Don't Transmit	NETCKX0.
	Transmit	NETCKX1.
BPO 4 State Code (BPO)	On	BPOENA1.
	*Off	BPOENA0.

Selection	Setting	Serial Command
Canadian 4 State Code	On	CANENA1.
	*Off	CANENA0.
Kix Code	*Off	KIXENA0.
	On	KIXENA1.
Australian 4 State Code	On	AUSENA1.
	*Off	AUSENA0.
Japanese Postal Code	On	JAPENA1.
	*Off	JAPENA0.
Planet Code	On	PLENA0.
	*Off	PLENA1.
<i>2D Matrix Symbology Selections</i>		
QR Code Settings	*Default All QR Code Settings*	QRCDFT.
QR Code	*On	QRCENA1.
	Off	QRCENA0.
QR Code Message Length	Minimum	QRDMIN.
	Maximum	QRDMAX.
Data Matrix Settings	*Default All Data Matrix Settings*	IDMDFT.
Data Matrix	*On	IDMENA1.
	Off	IDMENA0.
Data Matrix Msg. Length	Minimum	IDMMIN.
	Maximum	IDMMAX.
MaxiCode Settings	*Default All MaxiCode Settings*	MAXDFT.
MaxiCode	*On	MAXENA1.
	Off	MAXENA0.
MaxiCode Msg. Length	Minimum	MAXMIN.
	Maximum	MAXMAX.
SCM Only	*Disable	MAXSCM0.
	Enable	MAXSCM1.
Aztec Code Settings	*Default All Aztec Code Settings*	
		AZTDFT.
Aztec Code	*On	AZTENA1.
	Off	AZTENA0.

Selection	Setting	Serial Command
Aztec Code Msg. Length	Minimum	AZTMIN.
	Maximum	AZTMAX.
¹ VeriCode Settings	*Default All VeriCode Settings*	VERDFT.
¹ VeriCode	*On	VERENA1.
	Off	VERENA0.
¹ VeriCode Size	Size A	VERSA.
	Size B	VERSB.
	Size C	VERSC.
	Size D	VERSD.
	Size E	VERSE.
Test Menu	*Off	TSTMNU0.
	On	TSTMNU1.
2D Scan Diagnostics	*Off	2DDIAG0.
	On	2DDIAG1.

¹ VeriCode settings are not available in the standard Imager. An Imager with VeriCode setting capability can be special ordered from the factory.

Query Commands

Several special characters can be used to query the Imager about its settings.

- ^** What is the default value for the setting(s).
- ?** What is the Imager's current value for the setting(s).
- *** What is the range of possible values for the setting(s). (The Imager's response uses a dash (-) to indicate a continuous range of values. A pipe (|) separates items in a list of non-continuous values.)

Examples of Query Commands

Example #1: What is the range of possible values for Codabar Coding Enable?

Enter: **cbrena*.**

Response: **CBRENA0-1[ACK]**

This response indicates that Codabar Coding Enable (CBRENA) has a range of values from 0 to 1 (off and on).

Example #2: What is the default value for Codabar Coding Enable?

Enter: **cbrena^.**

Response: **CBRENA1[ACK]**

This response indicates that the default setting for Codabar Coding Enable (CBRENA) is 1, or on.

Example #3: What is the Imager's current setting for Codabar Coding Enable?

Enter: **cbrena?.**

Response: **CBRENA1[ACK]**

This response indicates that the Imager's Codabar Coding Enable (CBRENA) is set to 1, or on.

Example #4: What are the Imager's settings for all Codabar selections?

Enter: cbr?.

Response: **CBRENA1[ACK],
CHK0[ACK],
CKX0[ACK],
SSX0[ACK],
MIN2[ACK],
MAX60[ACK],
DFT[ACK].**

This response indicates that the Imager's Codabar Coding Enable (CBRENA) is set to 1, or on;
the Check Character (CHK and CKX) is set to 0, or No Check Character;
the Start/Stop Character is set to 0, or Don't Transmit;
the Minimum Message Length (MIN) is 2 characters;
the Maximum Message Length (MAX) is 60 characters;
and the Default setting (DFT) has no value.

Button Bar

The Quick*View button bar and the button functions are shown below.

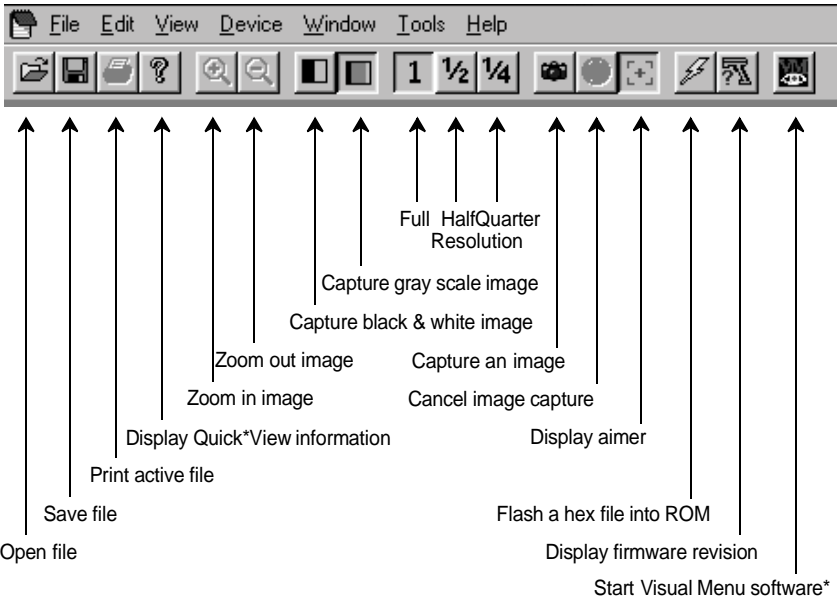

*This icon only appears if you have Visual Menu software installed. Visual Menu is available free of charge from the Welch Allyn website at <http://dcd.welchallyn.com/techsprt/download/software.htm>.



Visual Menu Introduction

Visual Menu provides the ability to configure a scanning device by connecting the scanner to the com port of a PC. Visual Menu allows you to download upgrades to a scanner's firmware, change programmed parameters, and create and print programming bar codes. Using Visual Menu, you can even set up the configuration for a scanner which is not attached to your PC. This enables one expert user to establish the configuration settings for all the devices your company uses, then save these configuration files for others. A configuration file can be e-mailed or, if you prefer, an expert user can create a bar code (or series of bar codes) which contains all the customized programming parameters, and mail or fax the bar code(s) to any location. Users in other locations can scan the bar code(s) to load in the customized parameters.

To communicate with a scanner, Visual Menu requires that the PC have at least one available serial communication port and an RS-232 cable to connect the port to the device. A power supply, which plugs into the cable, is also required.

Visual Menu Operations

The Visual Menu program performs the following operations:

- Displays all configuration data, and saves the information to a file on your PC.
- Configures the device to meet your specific requirements. Visual Menu has all the programming parameters which are available via programming bar codes in this User's Guide.
- Creates and prints a clone bar code which contains the program and configuration data from one device. This bar code can then be used to program additional devices with the same parameters.
- Selects a device from a list, then performs offline or online file configuration for that device.

Temporary Visual Menu Configuration

For quick download communication configuration, scan the **Visual Menu** bar code to temporarily configure the scanner for Visual Menu settings.

Note: If you have a unit capable of keyboard wedge mode, scan the bar code below and the unit will communicate in RS-232 mode, allowing it to work with Visual Menu. To convert the scanner back to keyboard wedge communication, cycle the power.



Visual Menu

Installing Visual Menu from the Web

10. Access the Welch Allyn DCD web site at <http://dcd.welchallyn.com>.
11. Click on the **Support** button, then click on the **Software Download** button.
12. When prompted, enter the user name: **pumpkin** and the password: **pie**
13. Locate the listing for **Visual Menu**. Click on the yellow **Download** button.
14. When prompted, select **Save File**, and save the files to the **c:\windows\temp** directory.
15. Once you have finished downloading the file, exit the web site.
16. Using Explorer, go to the **c:\windows\temp** file.
17. Double click on the **Visualmenu.exe** file. Follow the screen prompts to install the Visual Menu program.
18. To start Visual Menu, from the Start Menu click on **Programs, Visual Menu, Visual Menu**.

Note: If you wish, you can create a shortcut to the Visual Menu executable on your desktop.

Interface Keys

Supported Interface Keys		IBM AT/XT and PS/2 Compatibles, WYSE PC/AT	IBM XTs and Compatibles	IBM, DDC, Memorex Telex, Harris*
NUL	00	Reserved	Reserved	Reserved
SOH	01	Enter (KP)	CR/Enter	Enter
STX	02	Caps Lock	Caps Lock	F11
ETX	03	ALT make	Reserved	F12
EOT	04	ALT break	Reserved	F13
ENQ	05	CTRL make	Reserved	F14
ACK	06	CTRL break	Reserved	F15
BEL	07	CR/Enter	CR/Enter	New Line
BS	08	Reserved	Reserved	F16
HT	09	Tab	Tab	F17
LF	0A	Reserved	Reserved	F18
VT	0B	Tab	Tab	Tab/Field Forward
FF	0C	Delete	Delete	Delete
CR	0D	CR/Enter	CR/Enter	Field Exit/New Line
SO	0E	Insert	Insert	Insert
SI	0F	Escape	Escape	F19
DLE	10	F11	Reserved	Error Reset
DC1	11	Home	Home	Home
DC2	12	Print	Print	F20
DC3	13	Back Space	Back Space	Back Space
DC4	14	Back Tab	Back Tab	Backfield/Back Tab
NAK	15	F12	Reserved	F21
SYN	16	F1	F1	F1
ETB	17	F2	F2	F2
CAN	18	F3	F3	F3
EM	19	F4	F4	F4
SUB	1A	F5	F5	F5
ESC	1B	F6	F6	F6
FS	1C	F7	F7	F7
GS	1D	F8	F8	F8
RS	1E	F9	F9	F9
US	1F	F10	F10	F10

* IBM 3191/92, 3471/72, 3196/97, 3476/77, Telex (all models)

Supported Interface Keys		IBM, Memorex Telex (102)*	Memorex Telex (88)**
NUL	00	Reserved	Reserved
SOH	01	Enter	Enter
STX	02	F11	PF10
ETX	03	F12	PF11
EOT	04	F13	PF12
ENQ	05	F14	Reserved
ACK	06	F15	Reserved
BEL	07	New Line	New Line
BS	08	F16	Field Forward
HT	09	F17	Field Forward
LF	0A	F18	Reserved
VT	0B	Tab/Field Forward	Field Forward
FF	0C	Delete	Delete
CR	0D	Field Exit	New Line
SO	0E	Insert	Insert
SI	0F	Clear	Erase
DLE	10	Error Reset	Error Reset
DC1	11	Home	Reserved
DC2	12	Print	Print
DC3	13	Back Space	Back Space
DC4	14	Back Tab	Back Field
NAK	15	F19	Reserved
SYN	16	F1	PF1
ETB	17	F2	PF2
CAN	18	F3	PF3
EM	19	F4	PF4
SUB	1A	F5	PF5
ESC	1B	F6	PF6
FS	1C	F7	PF7
GS	1D	F8	PF8
RS	1E	F9	PF9
US	1F	F10	Home

* IBM 3196/97, 3476/77, 3191/92, 3471/72, Memorex Telex (all models) with 102 key keyboards

** Memorex Telex with 88 key keyboards

Supported Interface Keys		Esprit 200, 400 ANSI	Esprit 200, 400 ASCII	Esprit 200, 400 PC
NUL	00	Reserved	Reserved	Reserved
SOH	01	New Line	New Line	New Line
STX	02	N/A	N/A	N/A
ETX	03	N/A	N/A	N/A
EOT	04	N/A	N/A	N/A
ENQ	05	N/A	N/A	N/A
ACK	06	N/A	N/A	N/A
BEL	07	New Line	New Line	New Line
BS	08	N/A	N/A	N/A
HT	09	Tab	Tab	Tab
LF	0A	N/A	N/A	N/A
VT	0B	Tab	Tab	Tab
FF	0C	N/A	N/A	Delete
CR	0D	New Line	New Line	New Line
SO	0E	N/A	N/A	Insert
SI	0F	Escape	Escape	Escape
DLE	10	F11	F11	F11
DC1	11	Insert	Insert	Home
DC2	12	F13	F13	Print
DC3	13	Back Space	Back Space	Back Space
DC4	14	Back Tab	Back Tab	Back Tab
NAK	15	F12	F12	F12
SYN	16	F1	F1	F1
ETB	17	F2	F2	F2
CAN	18	F3	F3	F3
EM	19	F4	F4	F4
SUB	1A	F5	F5	F5
ESC	1B	F6	F6	F6
FS	1C	F7	F7	F7
GS	1D	F8	F8	F8
RS	1E	F9	F9	F9
US	1F	F10	F10	F10



Product Specifications

<i>Parameter</i>	<i>Specification</i>
Dimensions Length	6.1 inches (15.4 cm) (4400) 4.85 inches (4.7 cm) (4700)
Height	5.6 inches (14.2 cm) (4400)
Width	1.85 inches (4.7 cm) (4700) 2.5 inches (6.3 cm) (4400 and 4700)
Weight	Less than 7.5 ounces (213 g), without cable
Illumination Source	660 nm (± 30 nm) illumination LEDs
Aiming Pattern Source	670 nm laser light, <1.0 mW
Focal Point (focus) Long Range High Density High Density ¹⁰	5 inches (12.7 cm) from Imager's nose 2 inches (5.1 cm) from Imager's nose 3 inches (7.62 cm) from Imager's nose
Depth of Field Long Range Long Range OCR High Density High Density ¹⁰ High Density OCR	2.0 to 9.0 inches (5.1 to 22.9 cm) 2.7 to 9 inches (6.8 to 22.9 cm) 1.7 to 2.4 inches (4.3 to 6.1 cm) 2.0 to 4.0 inches (5.1 to 10.2 cm) 1.5 to 4.6 inches (3.8 to 11.7 cm)
Field of View Long Range High Density High Density ¹⁰	1 by 1.3 inches (2.54 by 3.3 cm) to 3.7 by 5.2 inches (9.4 by 13.2 cm) 0.6 by 0.8 inches (1.5 by 2.0 cm) to 1.3 by 1.8 inches (3.3 by 4.6 cm) 1 by 1.3 inches (2.5 by 3.3 cm) to 2.25 by 3 inches (5.7 by 7.6 cm)
Resolution Long Range Long Range OCR High Density High Density ¹⁰ High Density OCR	10 mil minimum, Linear symbol 15 mil minimum, 2D Matrix symbol 6 point (20 cpi) OCR text 4 mil minimum, Linear symbol 6.6 mil minimum, 2D Matrix symbol 5 mil minimum Linear 10 mil minimum 2D Matrix symbol 6 point (20 cpi) OCR text
Rotational Sensitivity OCR Text	360° around optical axis 85° around optical axis
Viewing Angle OCR Text	$\pm 35^\circ$ at the nominal operating distance $\pm 25^\circ$
Motion Sensitivity	approx. 2 inches (5 cm) per second of lateral motion

<i>Parameter</i>	<i>Specification</i>
Ambient Light	Total darkness to 100,000 Lux (sunlight)
Video Image	8-bits per pixel
Operating Voltage	5.0 VDC - 14.0 VDC (with cable)
Current Draw - 4400 Low Power Mode Medium Power Mode High Power Mode	.9 A average @ 5 VDC 1 A average @ 5 VDC 1.2 A average @ 5 VDC
Current Draw - 4700 Low Power Mode Medium Power Mode High Power Mode	330 mA average @ 5 VDC 430 mA average @ 5 VDC 620 mA average @ 5 VDC
Noise Immunity	100 mV peak to peak
Temperature Ranges	Operating 32° F to +122° F (-0C to +50C) Storage -40° F to +158° F (-40C to +70C)
Humidity	95% RH non-condensing, at +50° C
Mechanical Shock	10 drops from 5 feet (1.5 m) to concrete
ESD Sensitivity	15 kV to any external surface
Agency Compliance	FCC Class B Canadian Class B CE DOC Class B CDRH Class II CDRH/IEC Class 2 UL/CUL Listed to UL1950 CSA 22.2 950 TUV Certified to EN60950 and EN 60825-1 Class 2 CTick

Cable Pinouts

RS-232 Output, external power (IT4400 and IT4700)

Decoded output data format is provided at the modular connector in the Imager. Interface cables normally supplied with the Imager are terminated with a 10 pin modular plug (P1) and a 9 pin Type D connector (P3) that is compatible with all Welch Allyn decoders and terminals. See chart below.

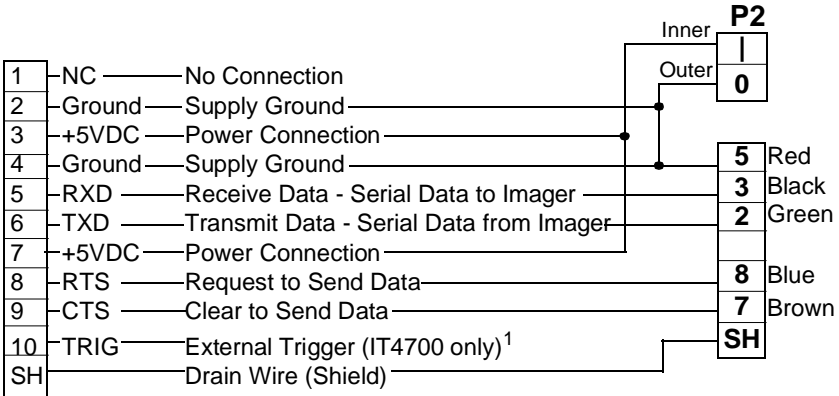
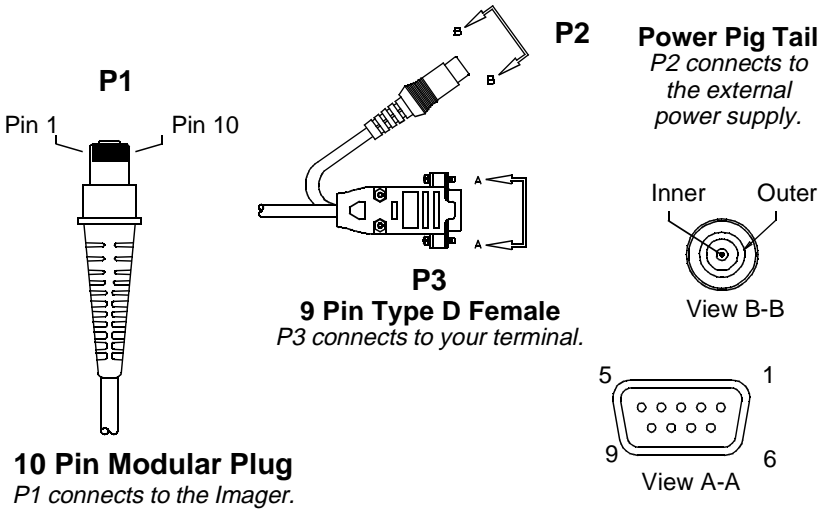

1. The HHLC mode is not available on an IT4700 with external trigger capability. Contact the factory if you require HHLC capability for an IT4700.

IT4400 Dimensions

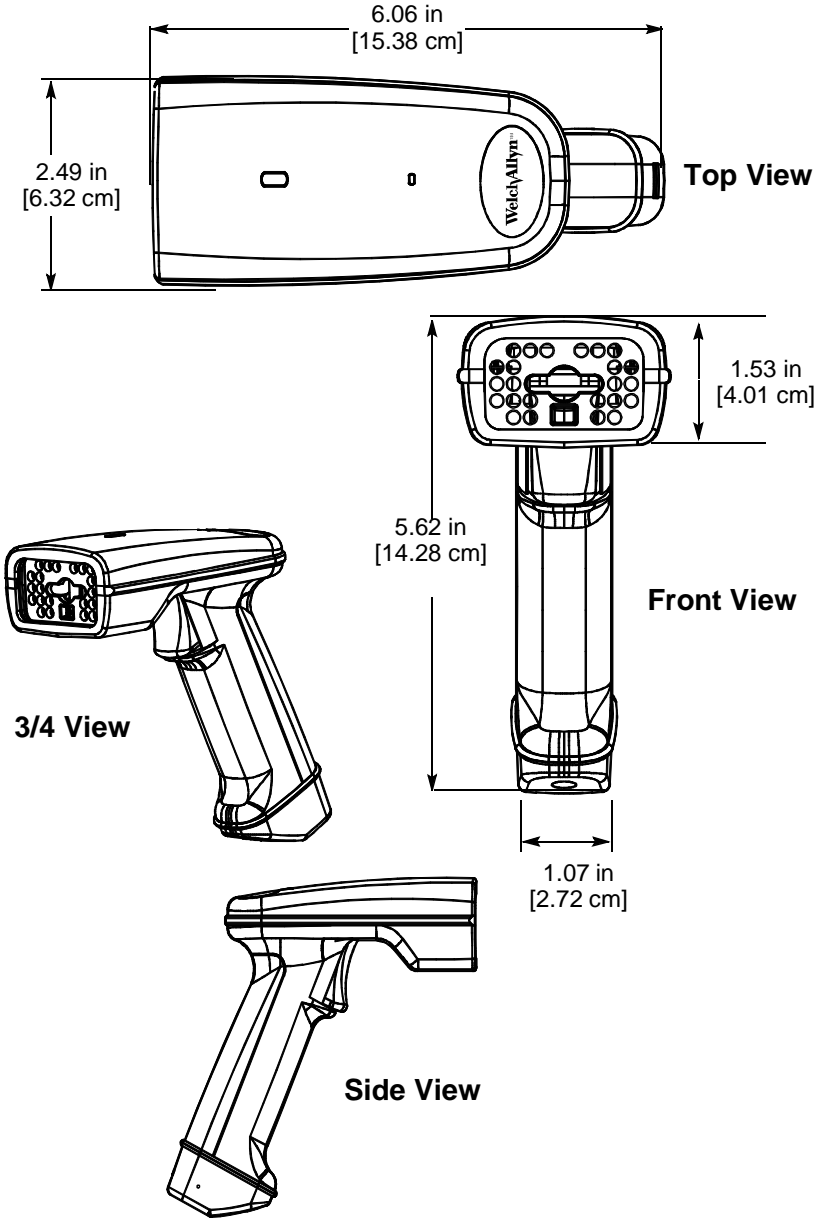

IT4700 Dimensions

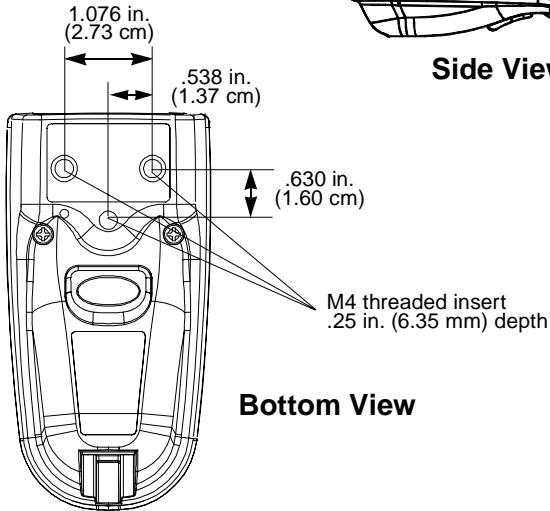
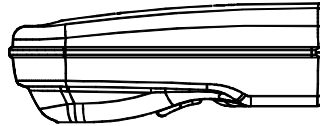
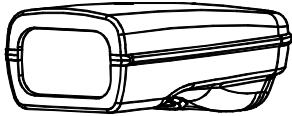
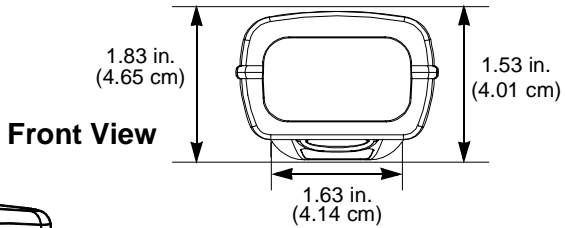
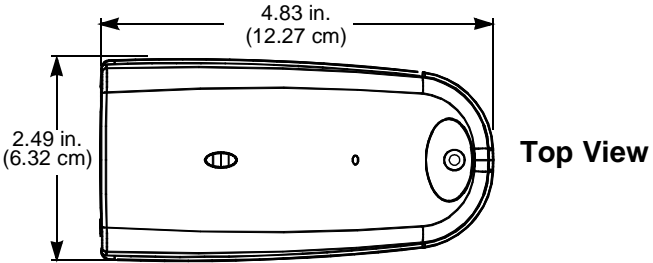



Repairs

Repairs and/or upgrades are not to be performed on this product. These services are to be performed only by an authorized service center. See page 11-1 for further information.

Maintenance

The IMAGETEAM 4400/IT4700 Imager provides reliable and efficient operation with a minimum of care. Although specific maintenance is not required, the following periodic checks ensure dependable Imager operation:

Cleaning the Imager's Window

Reading performance may degrade if the Imager's window is not clean. If the window is visibly dirty, or if the Imager isn't operating well, clean the window with a soft cloth or facial tissue dampened with water (or a mild detergent- water solution). If a detergent solution is used, rinse with a clean tissue dampened with water only.

The Imager's housing may also be cleaned the same way.



Caution:

Do not submerge the Imager in water. The Imager's housing is not water-tight.

Do not use abrasive wipers or tissues on the Imager's window - abrasive wipers may scratch the window.

Never use solvents (alcohol or acetone) on the housing or window - solvents may damage the finish or the window.

Inspecting Cords and Connectors

Inspect the Imager's interface cable and connector for wear or other signs of damage. A badly worn cable or damaged connector may interfere with Imager operation. Contact your Welch Allyn distributor for information about cable replacement. Cable replacement instructions are on the next page.

Examining the Imager's Housing

Routinely examine the Imager's housing for signs of damage. A damaged housing may cause the internal components to move and may result in a malfunctioning Imager.

Replacing the Interface Cable

The standard interface cable is attached to the Imager with an 10-pin modular connector. When properly seated, the connector is held in the Imager's handle by a flexible retention tab. The cable is designed to be field replaceable.

- Order replacement cables from Welch Allyn or from an authorized distributor.
- When ordering a replacement cable, specify the cable part number of the original interface cable.

To Replace the IT4400 Interface Cable:

1. Turn the power to the host system OFF.
2. Disconnect the Imager's cable from the terminal or computer.
3. Locate the small hole on the side of the Imager's handle near the base (cable release).
4. Straighten one end of a paper clip.
5. Insert the end of the paper clip into the small hole and press in. This depresses the retention tab, releasing the connector. Pull the connector out of the Imager's handle while maintaining pressure on the paper clip.
6. Replace with the new cable. Insert the connector into the opening at the base of the Imager's handle. Press firmly. The connector is "keyed" to go in only one way, and will click into place.

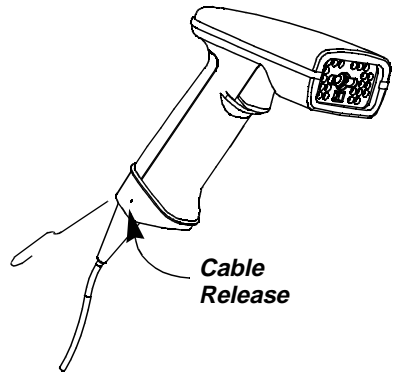

To Replace the IT4700 Interface Cable:

1. Turn the power to the host system OFF.
2. Disconnect the Imager's cable from the terminal or computer.
3. Insert a small, flat head screwdriver into the slot between the cable and the back end of the housing.
4. Press the screwdriver tip down to depress the retention tab, releasing the connector.
5. Pull the connector out of the Imager while maintaining pressure on the screwdriver.
6. Replace with the new cable.
Insert the connector into the opening at the base of the Imager. Press firmly. The connector is "keyed" to go in only one way, and will click into place.

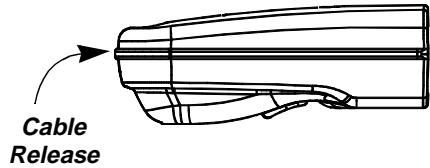

Troubleshooting

The Imager automatically performs self-tests whenever you turn it on. If your Imager is not functioning properly, review the following Troubleshooting Guide to try to isolate the problem.

Troubleshooting Guide

Is the power on? Are the illumination LEDs on?

If the illumination LEDs in the Imager aren't illuminated, check that:

1. The cable is connected properly.
2. The host system power is on (if external power isn't used).

Is the Imager having trouble reading your symbols?

If the Imager isn't reading symbols well, check that the symbols:

1. Aren't smeared, rough, scratched, or exhibiting voids.
2. Aren't coated with frost or water droplets on the surface.
3. Are enabled in the Imager or in the decoder the Imager connects to.

Application Support

If you are still experiencing problems, call your Distributor or Welch Allyn:

315-685-2476
8 a.m. to 6 p.m. EST

Fax: 315-685-4960

Web Site: dcd.welchallyn.com

E-Mail: dcd_techsupt@mail.welchallyn.com



For more information on customer support or warranty, see the next two sections.



Obtaining Factory Service

Welch Allyn provides service for all its products through a service center located at its manufacturing facilities in Skaneateles, New York. To obtain warranty or non-warranty service, return the unit to Welch Allyn (postage paid) with a copy of the dated purchase record attached.

In the United States, please contact the Welch Allyn Product Service Department at the address/telephone number listed below to obtain a Return Material Authorization number (RMA #).

Main Office Welch Allyn, Inc.

Data Collection Division
4619 Jordan Road
P.O. Box 187
Skaneateles Falls, New York 13153-0187

Product Service Department
Telephone: (315) 685-4278 or 685-4360
Fax: (315) 685-4156

For service in Europe, please contact your Welch Allyn representative (at address below) or your local distributor.

European Office Welch Allyn UK Ltd.

Dallam Court
Dallam Lane
Warrington
Cheshire WA2 7LT
United Kingdom

Telephone: Int+44 (0) 1 925 240055
or Int+353 1 216 0070
Fax: Int+44 (0) 1 925 631280
or Int+353 1 295 6353

For service in Asia, please contact your Welch Allyn representative (at address below) or your local distributor.

**Asia/Pacific Office
Welch Allyn**

10/F Tung Sun Commercial Centre
194-200 Lockhart Road
Wanchai, Hong Kong

Telephone: Int+852-2511-3050 or 2511-3132
Fax: Int+852-251-1355

For service in Japan, please contact your Welch Allyn representative (at address below) or your local distributor.

**Japan Office
Welch Allyn, Ltd.**

Bon Marusan 8F
3-5-1 Kanda-Jinbocho
Chiyoda-ku
Tokyo 101, Japan

Telephone: Int+81-3-5212-7392
Fax: Int+81-3-3261-7372

For service in Latin America, please contact your Welch Allyn representative (at address below) or your local distributor.

**Latin America Office
Welch Allyn, Ltd.**

5150 North Tamiami Trail
Suite 302
Naples, FL 34103-2821

Telephone: (941) 263-7600
Fax: (941) 263-9689

Help Desk

If, after reviewing the Troubleshooting Guide (page 10-4), you still need assistance installing or troubleshooting your Imager, please call your Distributor or the Help Desk:

Telephone: (315) 685-2476

Limited Warranty

Welch Allyn, Inc., hereby warrants its products to be functional and free from manufacturing defects at the time of delivery. Welch Allyn, Inc. further warrants that it will replace or repair, at its option, any unit that fails to perform according to Welch Allyn's published specifications during a period of three (3) years from the time of shipment by Welch Allyn, Inc. to the user at the time it is purchased from any of Welch Allyn Inc.'s Authorized Distributors. Any attempt on the part of the user to disassemble or service the equipment shall void the warranty.

The warranty does not apply to product which have been damaged by improper handling, shipping, or misuse. The warranty does not apply, if, in the sole opinion of Welch Allyn, Inc., the unit has been damaged by accident, misuse, neglect, improper shipping and handling. Since the unit is sensitive to static, the responsibility to protect it from static damage is solely that of the user. The warranty is valid only if the unit or Imager has not been tampered with or serviced by any party unauthorized by Welch Allyn, Inc. as a repair facility.

THE WARRANTIES SET FORTH HEREIN ARE IN LIEU OF ANY AND ALL OTHER WARRANTIES EXPRESSED OR IMPLIED INCLUDING THE WARRANTIES OF MERCHANTABILITY AND FITNESS FOR A PARTICULAR PURPOSE. THE BUYER ACKNOWLEDGES THAT NO OTHER REPRESENTATIONS WERE MADE OR RELIED UPON WITH RESPECT TO THE QUALITY AND FUNCTION OF THE BOARD AND IMAGER HEREIN SOLD.

In no event shall Welch Allyn, Inc. or its resellers be liable for any loss, inconvenience or damage whether direct, incidental, consequential or otherwise, and whether caused by negligence or other fault resulting from the breach of any express warranty except as set forth herein. Some states do not allow the exclusion or limitation of incidental or consequential damages, so the above limitations or exclusions may not apply to you.

This warranty gives you specific legal rights and you may also have other rights which vary from state to state or country to country.



Index

A

- Add AIM I.D. Prefix to All Symbologies 2-31
 - Serial Command 6-20
- Add Code I.D. Prefix to All Symbologies 2-31
 - Serial Command 6-20
- Add CR Suffix to All Symbologies 2-31
 - Serial Command 6-20
- AIM I.D. Prefix
 - Add to all Symbologies 2-31
- Aimer Delay 2-18
 - Serial Command 6-19
- Aimer Interval 2-19
 - Serial Command 6-19
- Aimer Timeout 2-18
 - Serial Command 6-19
- Alternate Data Formats 2-40
 - Serial Command 6-21
- ASCII Conversion Chart 2-34
- AutoTrigger Selections
 - Presentation Mode 2-21
- Aztec Code Selections 3-32
 - Serial Commands 6-26

B

- Baud Rate 2-12
 - Serial Command 6-18
- Beeper
 - Power Up 2-24
 - Volume
 - Serial Command 6-20
- Boot Code Revision 2-3
 - Serial Command 6-17

C

- Cable
 - Replacing 10-2
- Cable Pinouts 9-3
- Carriage Return Suffix
 - Add to all Symbologies 2-31
- Codabar Selections
 - Serial Commands 6-21
- Codablock Selections 4-2
 - Serial Commands 6-25
- Code 128 Selections 3-11
 - Serial Commands 6-23
- Code 39 Selections 3-4
 - Serial Commands 6-22
- Code 49 Selections 3-24
 - Serial Commands 6-25
- Code 93 Selections 3-10
 - Serial Commands 6-23
- Code I.D. Prefix
 - Add to all Symbologies 2-31
- Communication Settings 2-11
- Composite Codes 3-25
- Connecting the scanner
 - Keyboard wedge 1-6
 - Serial port 2-10
- Conversion Chart
 - Decimal to Hex to ASCII 2-34

D

- Data Format
 - Require 2-39
 - Serial Command 6-21
 - Data Format Editor 2-38
 - Commands 2-36
 - Overview 2-35
 - Programming codes 2-38
 - Serial Command 6-21
-

Data Formats
 Show 2-2, 2-39
 Serial Command 6-21

Data Formatter 2-39
 Serial Command 6-21

Data Matrix Selections 3-29
 Serial Commands 6-26

Decimal to Hex to ASCII Conversion
Chart 2-34

Default Settings 5-1

Demo Screens 6-5
 Bills of Lading 6-9
 Electronic Parts Manufacturing
 6-6
 Patient Registration 6-8
 Shipping 6-7
 Signature Capture 6-10

Dimensions 9-4

Disable All Symbologies 2-3
 Serial Command 6-17

E

EAN/JAN 13 Selections 3-14
 Serial Commands 6-23

EAN/JAN 8 Selections 3-13
 Serial Commands 6-23

Enable All Symbologies 2-3
 Serial Command 6-17

F

Factory Default Settings
 HD 2-2
 HD10 2-2
 LR 2-2
 Serial Command 6-17

Flow Control
 Hardware 2-14
 Serial Command 6-18
 Software 2-14

Serial Command 6-18

H

Hardware Flow Control 2-14
 Serial Command 6-18

Hex Chart 2-34

I

Iata 2 of 5 Selections 3-9

Installation
 Keyboard Wedge 1-6
 Serial Port 2-10

Intercharacter Delay 2-26
 Serial Command 6-20

Interface Keys 8-1

Interfunction Delay 2-27
 Serial Command 6-20

Interleaved 2 of 5 Selections 3-7
 Serial Commands 6-22

Intermessage Delay 2-28
 Serial Command 6-20

ISBT Symbology 3-12
 Serial Command 6-23

K

Keyboard Country
 Serial Command 6-17

Keyboard Modifiers
 Serial Command 6-17

Keyboard Style
 Serial Command 6-17

Keyboard wedge connection 1-6

L

Labels
 Safety and Identification 1-3

Laser Safety Instructions 1-5

LED

- Flashing 2-17
 - Serial Command 6-19

- Power Levels 2-17
 - Serial Command 6-19

- Scan Stand Intensity 2-20
 - Serial Command 6-19

- Scan Stand Lights
 - Serial Command 6-19

- Load New Imager Software
 - Using Quick*View 6-14

M

- Maintenance 10-1

- MaxiCode Selections 3-30
 - Serial Commands 6-26

- Micro PDF Selections 3-23
 - Serial Commands 6-25

- Money
 - reading serial numbers 4-1

- Multiple Symbols
 - Serial Command 6-21

N

- No Read 2-45
 - Serial Command 6-21

O

- OCR Programming 4-1

- OCR Templates 4-3

- Online Programming 7-1

- Open Com Port 6-13

- Output Sequence
 - Descriptions and Examples 2-41, 4-3

- Require 2-43
 - Serial Command 6-21

- Output Sequence Editor 2-44, 4-7

- Serial Command 6-21
- Overview 1-1

P

- Parity 2-11
 - Serial Command 6-18

- PDF 417 Selections 3-22
 - Serial Commands 6-25

- Pinouts
 - Cables 9-3

- Postal Code Selections
 - Serial Commands 6-25

- Power Hold Mode 2-16
 - Serial Command 6-19

- Power PC Revision 2-3
 - Serial Command 6-17

- Power Saving Mode 2-16
 - Serial Command 6-19

- Power Settings
 - Using Quick*View 6-14

- Power Up Beeper 2-24
 - Serial Command 6-20

- Prefix
 - Programming codes 2-32
 - Serial Command 6-20

- Prefix/Suffix
 - Adding or removing 2-30

- Prefix/Suffix Overview 2-29

- Presentation Aimer
 - Serial Command 6-20

- Presentation Default
 - Serial Command 6-19

- Presentation Mode
 - Aimer 2-22
 - Default 2-21, 2-25
 - Presentation Reread Delay 2-21
 - Serial Command 6-19

- Print Weight 2-46
 - Serial Command 6-21

Q

- QR Code Selections
 - Serial Commands 6-26
- Query Commands 6-28
- Quick*View 6-1
 - Button Bar 6-29
 - Demo Screens 6-5
 - Imager Power Settings 6-14
 - Installation 6-1
 - Load New Imager Software 6-14
 - Open Com Port 6-13
 - Query Commands 6-28
 - Reporting Firmware Revision 6-13
 - RS-232 Serial Commands 6-15
 - Scan Data Window 6-4
 - Serial Programming Commands 6-15
 - Snapshot 6-11, 6-12
 - Trigger Settings 6-14

R

- Reporting Firmware Revision
 - Using Quick*View 6-13
- Require Data Format 2-39
 - Serial Command 6-21
- Require Output Sequence 2-43
 - Serial Command 6-21
- Reset Factory Settings 2-2
 - Serial Command 6-17
- Revision Selections 2-3
 - Serial Commands 6-17
- RS-232 Communication
 - Serial Command 6-18
- RSS-14 Selections 3-19
 - Serial Commands 6-24

S

- Scan Data Window 6-4
 - Scan Stand Selections 2-20
 - Serial Command 6-19
 - SCM Selections
 - Serial Commands 6-26
 - Serial Programming Commands 6-15
 - Add AIM I.D. Prefix to All Symbologies 6-20
 - Add Code I.D. Prefix to All Symbologies 6-20
 - Add CR Suffix to All Symbologies 6-20
 - Aimer Delay 6-19
 - Aimer Interval 6-19
 - Aimer Timeout 6-19
 - Alternate Data Formats 6-21
 - Aztec Code Selections 6-26
 - Baud Rate 6-18
 - Beeper Volume 6-20
 - Boot Code Revision 6-17
 - Codabar Selections 6-21
 - Codablock Selections 6-25
 - Code 128 Selections 6-23
 - Code 39 Selections 6-22
 - Code 49 Selections 6-25
 - Code 93 Selections 6-23
 - Data Format Editor 6-21
 - Data Formatter 6-21
 - Data Matrix Selections 6-26
 - Disable All Symbologies 6-17
 - EAN/JAN 13 Selections 6-23
 - EAN/JAN 8 Selections 6-23
 - Enable All Symbologies 6-17
 - Factory Default Settings 6-17
 - Hardware Flow Control 6-18
 - Intercharacter Delay 6-20
 - Interfunction Delay 6-20
-

Interleaved 2 of 5 Selections 6-22

Intermessage Delay 6-20

ISBT 6-23

Keyboard Country 6-17

Keyboard Modifiers 6-17

Keyboard Style 6-17

LED Flashing 6-19

LED Power Levels 6-19

MaxiCode Selections 6-26

Micro PDF Selections 6-25

Multiple Symbols 6-21

No Read 6-21

Output Sequence Editor 6-21

Parity 6-18

PDF 417 Selections 6-25

Postal Code Selections 6-25

Power Hold Mode 6-19

Power PC Revision 6-17

Power Saving Mode 6-19

Power Up Beeper 6-20

Prefix 6-20

Presentation Aimer 6-20

Presentation Default 6-19

Presentation Mode 6-19

Presentation Reread Delay 6-19

Print Weight 6-21

QR Code Selections 6-26

Require Data Format 6-21

Require Output Sequence 6-21

RS-232 Communication 6-18

RSS-14 6-24

Scan Stand 6-19

Scan Stand LED Intensity 6-19

Scan Stand Lights 6-19

SCM Selections 6-26

Serial Triggering 6-18

Set Print Weight 6-21

Show Data Formats 6-17, 6-21

Show Software Revision 6-17

Software Flow Control 6-18

Suffix 6-20

Terminal ID 6-17

UPC A Selections 6-23

UPC E0 Selections 6-24

UPC E1 Selections 6-24

User Specified Intercharacter Delay 6-20

VeriCode Selections 6-27

Word Length Data Bits 6-18

Word Length Stop Bits 6-18

Zoom 6-20

Zoom Placement 6-20

Serial Triggering 2-15

Serial Command 6-18

Service 11-1

Show Data Formats 2-2, 2-39

Serial Command 6-17, 6-21

Show Software Revision 2-2

Serial Command 6-17

Snapshot 6-11, 6-12

Software Flow Control 2-14

Serial Command 6-18

Software Revision

Show 2-2

Serial Command 6-17

Specifications 9-1

Status Check 2-2

Suffix

Programming codes 2-32

Serial Command 6-20

Symbology

Enable/Disable All 2-3

Symbology Chart 2-33

T

Templates

OCR 4-3

Terminal ID

Serial Command 6-17
Trigger Settings
 Using Quick*View 6-14
Troubleshooting 10-4

U

Unpacking Imager 1-2
UPC A Selections 3-16
 Serial Commands 6-23
UPC E0 Selections 3-17
 Serial Commands 6-24
UPC E1 Selections 3-18
 Serial Commands 6-24
User Specified Intercharacter Delay
 Serial Command 6-20

V

VeriCode Selections 3-33
 Serial Commands 6-27
Visual Menu 7-1

W

Word Length
 Data Bits 2-13
 Serial Command 6-18
 Stop Bits 2-13
 Serial Command 6-18

Z

Zoom 2-22
 Serial Command 6-20
Zoom Placement 2-23
 Serial Command 6-20

Sample Symbols

UPC A

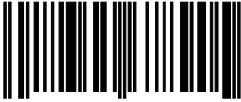

0 123456 7890

Interleaved 2 of 5



1234567890

Code 128



Code 128

EAN 13

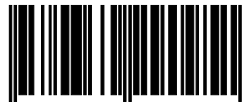

9 780330 290951

Code 39

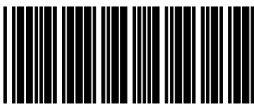

BC321

Codabar



A13579B

Sample Symbols

PDF417



Car Registration

Postnet



Zip Code

Code 49



1234567890

Data Matrix



Test Symbol

OCR-A Sample

55836540

QR Code



Numbers

OCR-B Sample

55836540

Sample Symbols

Aztec



Package Label

Aztec Mesa Code



Test Message

MaxiCode

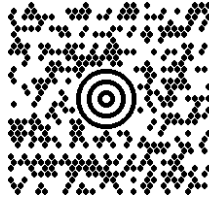

Test Message

Micro PDF417



Test Message

Programming Chart



0



1



2



3



4



5



6



7

Programming Chart



8



9



A



B



C



D



E



F



Save



Discard

Programming Chart (OCR)



a



c



d



e



l



t



Save



Discard



4619 Jordan Road

P.O. Box 187

Skaneateles Falls, New York 13153-0187

44/4700/UG Rev H