



**DS2100**  
Installation Manual





# **DS2100**

## **INSTALLATION MANUAL**





DATALOGIC S.p.A.  
Via Candini 2  
40012 - Lippo di Calderara di Reno  
Bologna - Italy

DS2100

Ed.: 02/2002

**ALL RIGHTS RESERVED**

Datalogic reserves the right to make modifications and improvements without prior notification.

Datalogic shall not be liable for technical or editorial errors or omissions contained herein, nor for incidental or consequential damages resulting from the use of this material.

Product names mentioned herein are for identification purposes only and may be trademarks and or registered trademarks of their respective companies.

© Datalogic S.p.A. 1998 - 2002

821000373 (Rev. C)

# CONTENTS

---

	<b>GUIDE TO INSTALLATION</b> .....	v
	<b>GENERAL VIEW</b> .....	vi
	<b>SAFETY PRECAUTIONS</b> .....	vii
	Laser Safety .....	vii
	Power Supply .....	ix
<b>1</b>	<b>GENERAL FEATURES</b> .....	1
1.1	Introduction .....	1
1.2	Description .....	1
1.3	Available Models .....	3
1.4	GFC-2100 Accessory Installation .....	4
<b>2</b>	<b>INSTALLATION</b> .....	5
2.1	Package Contents .....	5
2.2	Mechanical Installation .....	6
2.3	Electrical Connections .....	7
2.3.1	Power Supply .....	9
2.3.2	Main Serial Interface .....	9
	RS232 Interface .....	10
	RS485 Full-Duplex Interface .....	11
	RS485 Half-Duplex Interface .....	12
	20 mA Current Loop Interface (INT-22 Accessory Only) .....	14
2.3.3	Auxiliary RS232 Interface .....	15
	Code Verifier .....	16
2.3.4	Inputs .....	16
2.3.5	Outputs .....	18
2.4	Positioning .....	19
2.5	Typical Layouts .....	20
2.5.1	Point-to-Point .....	21
2.5.2	Pass-Through .....	22
2.5.3	RS232 Master/Slave .....	23
2.5.4	RS485 Master/Slave .....	24
2.5.5	Multiplexer Layout .....	25
<b>3</b>	<b>READING FEATURES</b> .....	26
3.1	Step-Ladder Mode .....	26
3.2	Picket-Fence Mode .....	27
3.3	Performance .....	28
3.3.1	Raster .....	28
3.4	Reading Diagrams .....	29

<b>4</b>	<b>MAINTENANCE</b> .....	<b>33</b>
4.1	Cleaning.....	33
<b>5</b>	<b>TECHNICAL FEATURES</b> .....	<b>34</b>

# GUIDE TO INSTALLATION

---

The following can be used as a checklist to verify all of the steps necessary for complete installation of the DS2100 scanner.

- 1) Read all information in the section "Safety Precautions" at the beginning of this manual.
- 2) Correctly position and mount the scanner for barcode reading according to the information in par. 2.2, 2.4 and 3.4.
- 3) Provide correct system cabling according to the signals necessary for your application (see all sub-paragraphs under 2.3). See also sub-paragraphs under 2.5 for reference.
- 4) Install the Configuration Disk.  
Upon successful completion of the installation, the readme.hlp file is opened, giving details about how to get started configuring your scanner.  
See also the [Guide To Rapid Configuration](#) link.  
Specific parameter details are available in the Help On Line.



**NOTE**

*Fine tuning of the scanner position for barcode reading can be accomplished using the Test Mode as described in WinHost.*

The installation is now complete.

# GENERAL VIEW

---

## DS2100

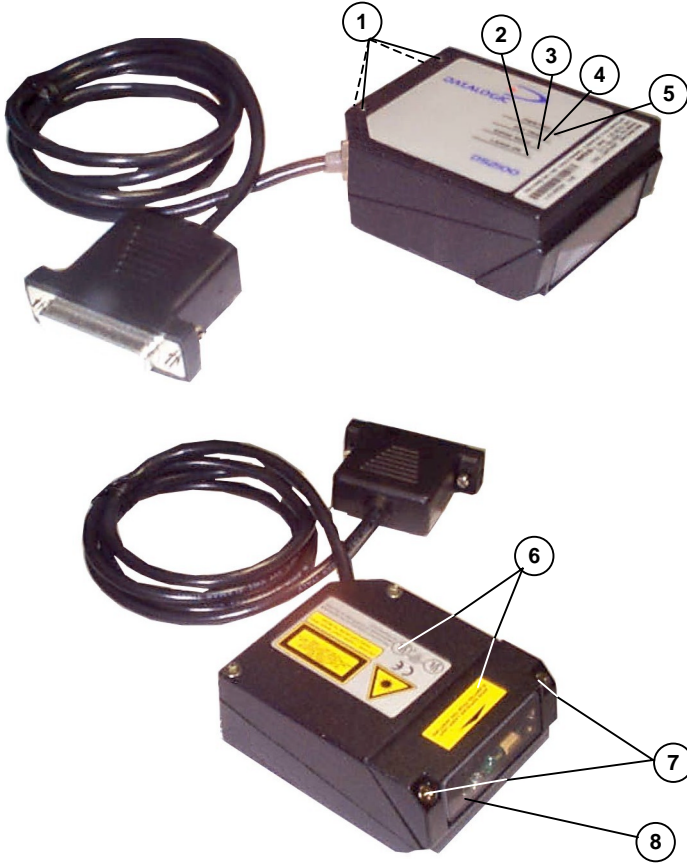

Figure A

- |                        |                                   |
|------------------------|-----------------------------------|
| ① Mounting Holes       | ⑤ Power On / Data TX LED          |
| ② Laser On LED         | ⑥ Warning and Device Class Labels |
| ③ Good Read LED        | ⑦ Accessory Mounting Holes        |
| ④ External Trigger LED | ⑧ Laser Beam Output Window        |



# SAFETY PRECAUTIONS

---

## LASER SAFETY

The following information is provided to comply with the rules imposed by international authorities and refers to the correct use of the DS2100 scanner.

### Standard Regulations

This scanner utilizes a low-power laser diode. Although staring directly at the laser beam momentarily causes no known biological damage, avoid staring at the beam as one would with any very strong light source, such as the sun. Avoid that the laser beam hits the eye of an observer, even through reflective surfaces such as mirrors, etc.

This product conforms to the applicable requirements of both IEC 825-1 and CDRH 21 CFR 1040 at the date of manufacture. The scanner is classified as a Class 2 laser product according to IEC 825-1 regulations and as a Class II laser product according to CDRH regulations.

There is a safety device which allows the laser to be switched on only if the motor is rotating above the threshold for its correct scanning speed.

The laser beam can be switched off through a software command (see also the WinHost Help On Line).



**WARNING**

*Use of controls or adjustments or performance of procedures other than those specified herein may result in exposure to hazardous visible laser light.*

The laser light is visible to the human eye and is emitted from the window on the front of the scanner (Figure A, 8).

Warning labels indicating exposure to laser light and the device classification are applied onto the body of the scanner (Figure A, 6).

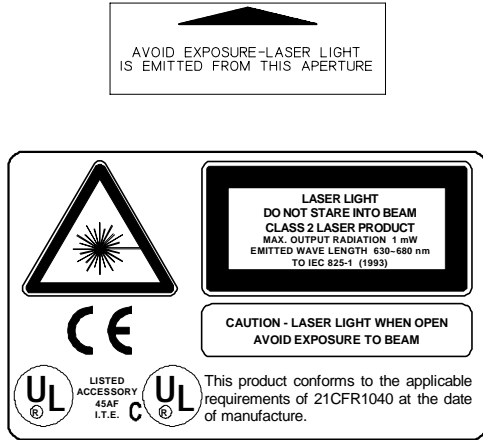

**Warning and device class labels**

Disconnect the power supply when opening the device during maintenance or installation to avoid exposure to hazardous laser light.

The laser diode used in this device is classified as a class 3B laser product according to IEC 825-1 regulations and as a Class IIIb laser product according to CDRH regulations. As it is not possible to apply a classification label on the laser diode used in this device, the following label is reproduced on the right.

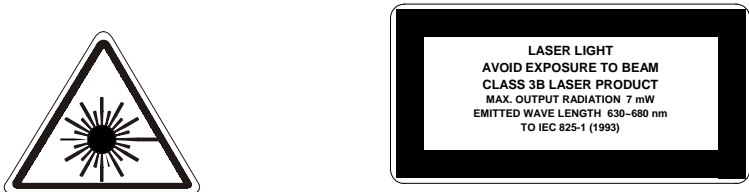

**Laser diode class label**

Any violation of the optic parts in particular can cause radiation up to the maximum level of the laser diode (7 mW at 630 to 680 nm).

## **POWER SUPPLY**

**- This product is intended to be installed by Qualified Personnel only.**

**- Models DS2100-X0XX, DS2100-X1XX:**

This accessory device is intended to be supplied by a UL Listed Power Unit with «Class 2» or LPS power source which supplies power directly to the scanner via the 25-pin connector.

**- Model DS2100-X3XX:**

This accessory device is intended to be supplied by a UL Listed Power Unit with «Class 2» or LPS power source which supplies power directly to the scanner via the 9-pin connector.



# 1 GENERAL FEATURES

---

## 1.1 INTRODUCTION

The DS2100 laser scanner satisfies the most advanced needs of a wide range of users. It has been developed focusing on the realistic requirements of its target market. The outstanding result is an extremely compact, cost-effective and easy to use industrial scanner.

**C-Programmability**            The DS2100 belongs to the generation of Datalogic scanners that operate under the 'C' programming environment, which is a recognized industry standard.

**Standard Application Program**            A standard application program is factory-loaded onto the DS2100. This program controls barcode reading, serial port interfacing, data formatting and many other operating and control parameters.

It is completely configurable from a host computer through the WinHost utility program provided on diskette with the scanner, or through ESC sequences via the serial interface.

**Custom Application Programs**            If the Standard Application Program does not meet your requirements, please contact your local Datalogic distributor.

## 1.2 DESCRIPTION

Some of the main features of DS2100 are listed below:

- small dimensions.
- scanning speed up to 800 scans/sec.
- raster version.
- modulated light versions for immunity to ambient light.
- 1 or 2 serial communication interfaces.
- supply voltage from 10 to 30 Vdc.
- reads all popular codes.

- test mode to verify the reading features and exact positioning of the scanner without the need for external tools.
- programmable in 4 different operating modes to suit the most various barcode reading system requirements.
- code verifier
- low power consumption.

The DS2100 uses a solid state laser diode as a light source; the light emitted has a wavelength between 630 and 680 nm. Refer to the section “Safety precautions” at the beginning of this manual for information on laser safety.

The protection class of the enclosure is IP65, the reader is therefore suitable for industrial environments where high protection against harsh external conditions is required.

The four LEDs on the side of the scanner indicate the following:

<b>PWR/TXD</b>	LED (red) (Figure A, 5) indicates the reader is connected to the power supply or, when blinking (green), data transmission.
<b>GOOD READ</b>	LED (red) (Figure A, 3) is used to signal the possibility of a successful barcode reading.
<b>EXT TRIG</b>	LED (yellow) (Figure A, 4) indicates external trigger activity. Refer to par. 2.3.4.
<b>LASER ON</b>	LED (green) (Figure A, 2) indicates laser ON state.

The screw holes on the body of the reader are for mechanical fixture (Figure A, 1).

### 1.3 AVAILABLE MODELS

The DS2100 scanner is available in versions that differ in regard to the following parameters:

- Resolution
- Interface module and termination of the cable
- Linear or raster models
- Performance

The following models are therefore available:

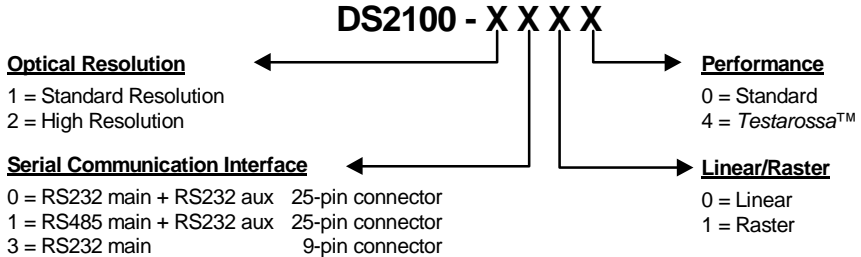

The following tables display each version's reading performance.

Version	Max Code Resolution	Speed
	mm (mils)	scans/s
1XX0	0.20 (8)	350
1XX4	0.20 (8)	800
2XX0	0.15 (6)	350
2XX4	0.12 (5)	600

Version	Reading Distance
1XX0	40 mm (1.6 in) - 300 mm (11.8 in) on 0.50 mm (20 mils) codes
1XX4	45 mm (1.8 in) - 300 mm (11.8 in) on 0.50 mm (20 mils) codes
2XX0	30 mm (1.2 in) - 90 mm (3.5 in) on 0.30 mm (12 mils) codes
2XX4	45 mm (1.8 in) - 100 mm (3.9 in) on 0.20 mm (8 mils) codes

See reading diagrams in par. 3.4 for further details.

## 1.4 GFC-2100 ACCESSORY INSTALLATION

GFC-2100 is a 90° deflection mirror available on request for DS2100. The installation of the 90° deflection mirror is very easy (Figure 1).



**CAUTION**

*Avoid any contact with the deflection mirror, mirrored rotor, the lenses or other optical components, otherwise the performance of the reader will be reduced.*

1. Turn off the device.
2. Remove the DS2100 scanning window unscrewing the two cover screws.
3. Fix the mirror to the device by means of the two fixing screws.
4. Remount the scanning window so that the opening face is now at 90° with respect to the DS2100 body.

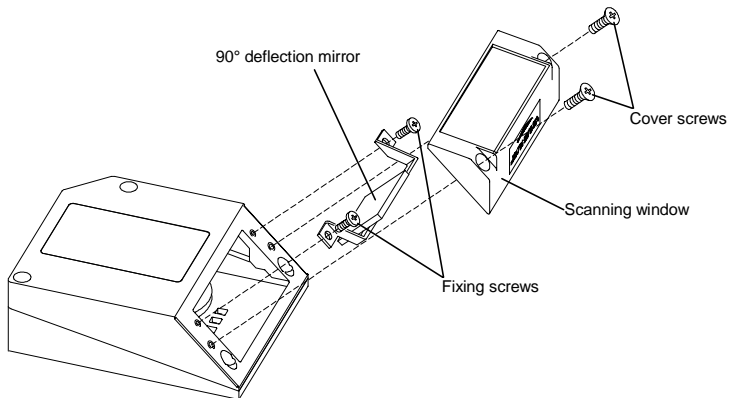

**Figure 1 - Installation of the deflection mirror**



## 2 INSTALLATION

---

### 2.1 PACKAGE CONTENTS

Verify that the DS2100 reader and all the parts supplied with the equipment are present and intact when opening the packaging; the list of parts includes:

- DS2100 reader with cable
- Installation manual
- Bar code test chart (PCS = 0.9)
- DS2100 configuration program disk
- Mounting kit:           - bracket  
                              - screws

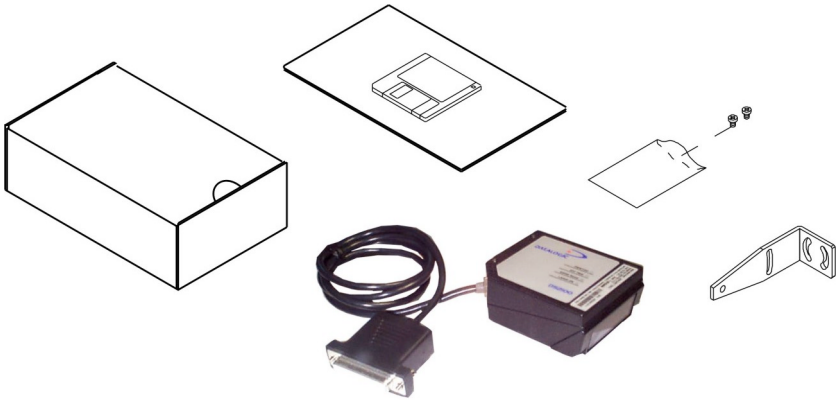

Figure 2 - DS2100 package contents

## 2.2 MECHANICAL INSTALLATION

DS2100 can be installed to operate in different positions. The four screw holes (M4 x 5) on the body of the reader are for mechanical fixture (Figure A, 1). The diagrams below give the overall dimensions of the scanner and mounting bracket and may be used for installation.

Refer to par. 2.4 for correct positioning.

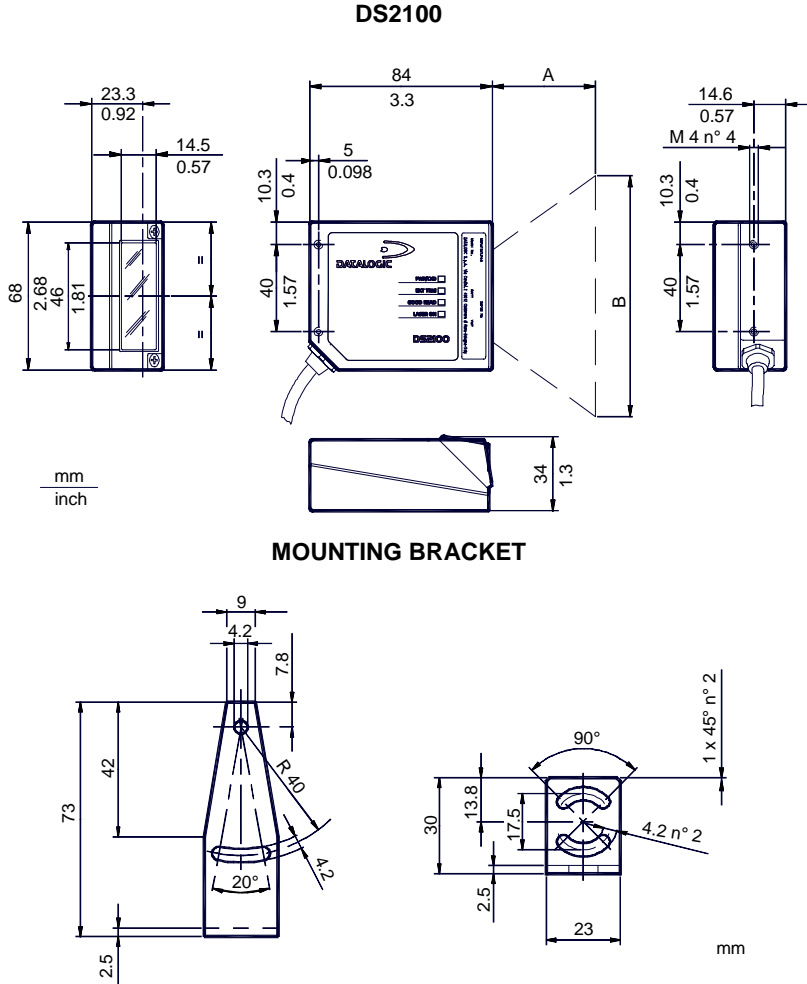



Figure 3 - Overall dimensions

### 2.3 ELECTRICAL CONNECTIONS

Several DS2100 models are equipped with a cable terminated by a 25-pin female D-sub connector for connection to the power supply and input/output signals. The details of the connector pins are indicated in the following table.



**CAUTION** Do not connect GND and SGND to different (external) ground references. GND and SGND are internally connected through filtering circuitry which can be permanently damaged if subjected to voltage drops over 0.8 Vdc.

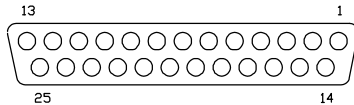

Figure 4 - 25-pin female D-sub connector

25-pin D-sub connector pinout		
Pin	Name	Function
13	VS	Power supply input voltage +
25	GND	Power supply input voltage -
1	CHASSIS	Chassis Ground
9	VS	External Trigger supply voltage +
18	EXT TRIG+	External Trigger +
19	EXT TRIG-	External Trigger -
8	OUT1 +	Output 1 +
11	OUT2 +	Output 2 +
12	OUT REF	Output reference
22	OUT REF	Output reference
20	RXAUX	Auxiliary RS232
21	TXAUX	Auxiliary RS232
23	CTSAUX	Auxiliary handshake RS232
24	RTSAUX	Auxiliary handshake RS232
6, 10, 14, 15, 16, 17	NC	Not Connected

Pin		RS232	RS485 full-duplex	RS485 half-duplex	20mA C.L. (INT-22 only)
2	Main interface signals, see par. 2.3.2.	TX232	TX485+	RTX485+	CLOUT+
3		RX232	RX485+		CLIN+
4		RTS232	TX485-	RTX485-	CLOUT-
5		CTS232	RX485-		CLIN-
7		SGND	SGND	SGND	

Some DS2100 models are equipped with a 9-pin female connector.

The details of the connector pins are indicated in the following table:

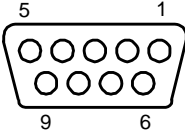
9-pin connector pinout			
Pin	Name	Function	
7	VS	Power supply input voltage +	<p><b>Figure 5 - 9-pin female connector</b></p>
5	GND	Power supply input voltage -	
8	EXT TRIG+	External Trigger +	
9	EXT TRIG-	External Trigger -	
1	CHASSIS	Chassis Ground	
2	TX232	TX RS232 Interface	
3	RX232	RX RS232 Interface	
4	CTS232	CTS RS232 Interface	
6	RTS232	RTS RS232 Interface	

### 2.3.1 Power Supply

Power can be supplied to the scanner through the pins provided on the 25- or 9-pin connector used for communication with the host (Figure 6):

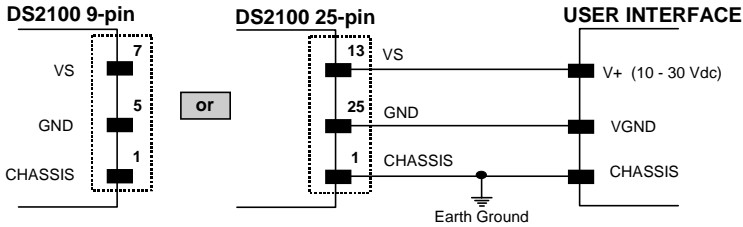

Figure 6 - Power supply connections

The power must be between 10 and 30 Vdc only.

It is recommended to connect pin 1 (CHASSIS) to a common earth ground.

### 2.3.2 Main Serial Interface

The signals relative to the following serial interface types are available on the input/output connector of DS2100 depending on the DS2100 model (see par. 1.3).

A passive 20-mA Current Loop interface is available if the optional INT-22 accessory is installed. This accessory interface replaces the main serial interface of the DS2100 model. The INT-22 accessory board is not available for DS2100-X3X0 models.

If the interface type is not compatible with the current communication handshaking, then the system forces the handshake to **none**.

**The parameters relative to the interface selected (baud rate, data bits, etc.) can be defined using the WinHost utility program or "Host Mode" programming procedure through ESC sequences installed from the diskette.**

Details regarding the connections and use of the interfaces are given in the next paragraphs.

## RS232 Interface

The serial interface is used in this case for point-to-point connections; it handles communication with the host computer and allows both transmission of code data and the programming of the scanner. This is the default setting.

The following pins are used for RS232 interface connection:

Connector		Name	Function
9-Pin	25-Pin		
2	2	TX232	transmitted data
3	3	RX232	received data
6	4	RTS232	request to send
4	5	CTS232	clear to send
5	7	GND/SGND	signal ground

It is always advisable to use shielded cables. The overall maximum cable length must be less than 15 m (49.2 ft).

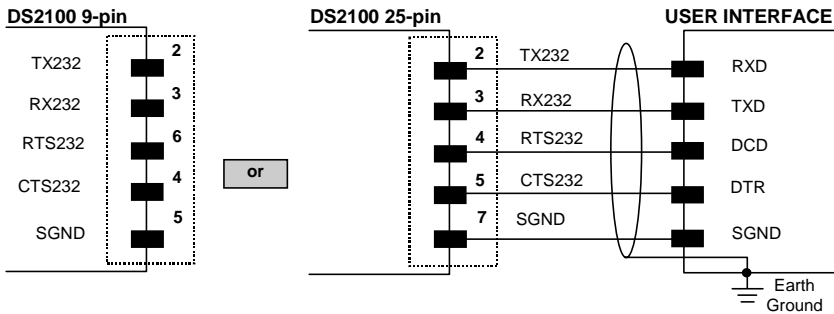

**Figure 7 – RS232 main interface connections using hardware handshaking**

The RTS232 and CTS232 signals control data transmission and synchronize the connected devices.

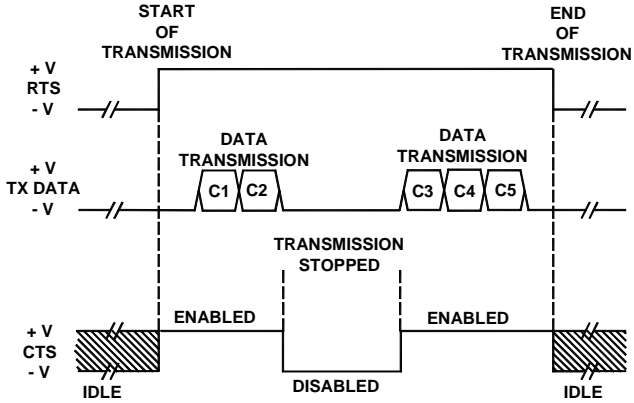

Figure 8 - RS232 control signals

If the RTS/CTS handshaking protocol is enabled, the DS2100 activates the RTS232 output to indicate a message is to be transmitted. The receiving unit activates the CTS232 input to enable the transmission.

### RS485 Full-Duplex Interface

The RS485 full-duplex (5 wires + shield) interface is used for non-pollled communication protocols in point-to-point connections over longer distances (max 1200 m / 3940 ft) than those acceptable for RS232 communications or in electrically noisy environments.

The connector pinout follows:

Connector 25-Pin	Name	Function
2	TX485+	RS485 transmitted data +
4	TX485-	RS485 transmitted data -
3	RX485+	RS485 received data +
5	RX485-	RS485 received data -
7	SGND	signal ground

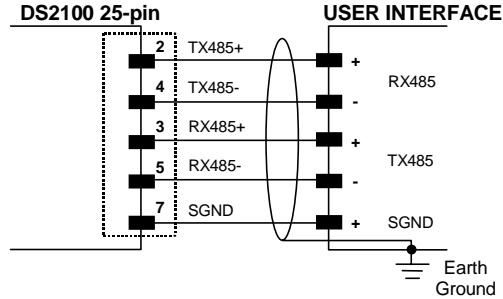

Figure 9 - RS485 full-duplex connections

## RS485 Half-Duplex Interface

The RS485 half-duplex (3 wires + shield) interface is used for polled communication protocols.

It can be used in a master/slave layout or for Multidrop connections with a Datalogic Multiplexer, (see par. 2.5.4 and 2.5.5) exploiting a proprietary protocol based on polled mode called MUX32 protocol, where a master device polls slave devices to collect data.

The connector pinout follows:

Connector	Name	Function
25-Pin		
2	RTX485+	RS485 transmitted/received data +
4	RTX485-	RS485 transmitted/received data -
7	SGND	signal ground

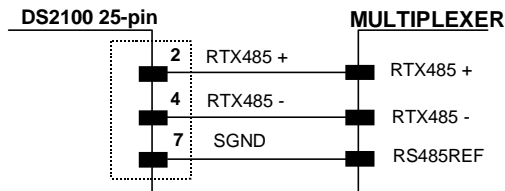

Figure 10 - RS485 half-duplex connections

This interface is forced by software when the protocol selected is MUX32 protocol.



In a Multiplexer layout or for slaves, the Multidrop address must also be set via serial channel by the WinHost utility or by ESC sequences.

Figure 11 shows a multidrop configuration with DS2100 scanners connected to a Multiplexer.

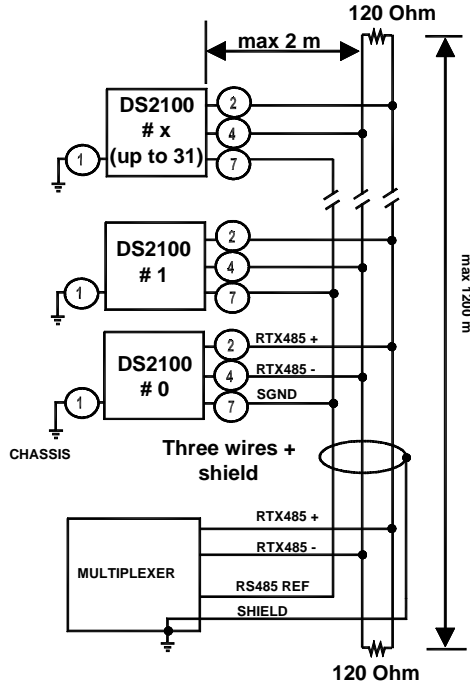

Figure 11 - DS2100 Multidrop connection to a Multiplexer

## 20 mA Current Loop Interface (INT-22 Accessory Only)

When the INT-22 accessory board is installed, the DS2100 is equipped with a 20 mA passive current loop.

The following pins of the 25-pin connector are used:

Connector 25-Pin	Name	Function
5	CLIN-	current loop input -
3	CLIN+	current loop input +
4	CLOUT-	current loop output -
2	CLOUT+	current loop output +

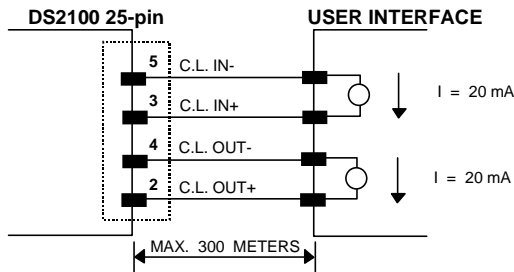

Figure 12 - 20 mA C.L. connections

### 2.3.3 Auxiliary RS232 Interface

The auxiliary serial interface is used exclusively for RS232 point-to-point connections.

The parameters relative to the aux interface (baud rate, data bits, etc.) as well as particular communication modes such as LOCAL ECHO can be defined using the WinHost utility program or "Host Mode Programming", installed from the diskette.

The following pins of the 25-pin connector are used to connect the RS232 auxiliary interface:

Connector	Name	Function
<b>25-Pin</b>		
20	RXAUX	received data
21	TXAUX	transmitted data
23	CTSAUX	clear to send
24	RTSAUX	request to send
7	SGND	signal ground

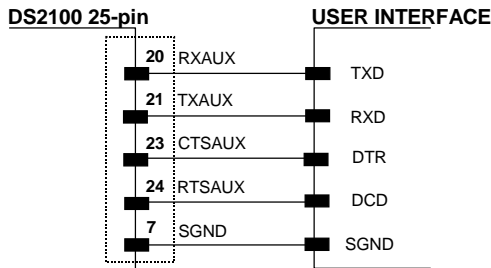

**Figure 13 - RS232 auxiliary interface connections using hardware handshaking**

When the auxiliary interface is permanently connected as part of the system cabling, it is recommended to connect the cable shield to earth ground.

The RTSAUX and CTSAUX signals control data transmission and synchronize the connected devices. If the RTS/CTS handshaking protocol is enabled, the DS2100 activates the RTSAUX output to indicate a message is to be transmitted. The receiving unit activates the CTSAUX input to enable the transmission.

## Code Verifier

If the DS2100 is used as a Code Verifier, it is possible to indicate to the scanner what code to store as the verifier code by means of an external hardware input.

The Code Verifier parameter must be enabled and the configuration parameters to allow correct Code Type reading must be saved to the scanner in order to read the verifier code.

To activate the input, connect together pins 23 and 24 (CTSAUX and RTSAUX) of the 25-pin connector (for example with a push-button), before the active edge of the External Trigger input (or before the code passes under the laser beam for the Automatic operating mode). The next read code will be stored as the verifier code in the scanner's RAM and NON-VOLATILE (EEPROM) memory by default. Then, the two pins must be disconnected.

Since it uses part of the RS232 auxiliary serial interface, this interface is limited when using this option and the Handshake selection must not be set to RTS/CTS.

### 2.3.4 Inputs

The inputs available on the connector supplied with the scanner are the pins relative to the External Trigger, as indicated below:

Connector		Name	Function
9-Pin	25-Pin		
8	18	EXT TRIG+	external trigger +
9	19	EXT TRIG-	external trigger -

The External Trigger input is used in the On-Line operating Mode and tells the scanner to scan for a code. The active state of this input is selected in software. Refer to the WinHost Help On Line.

The yellow LED (Figure A, 4) is on when the External Trigger forces a current flow through the EXT TRIG+ and EXT TRIG- pins.

This input is optocoupled and can be driven by both an NPN or PNP type command. The connections are indicated in the following diagrams:

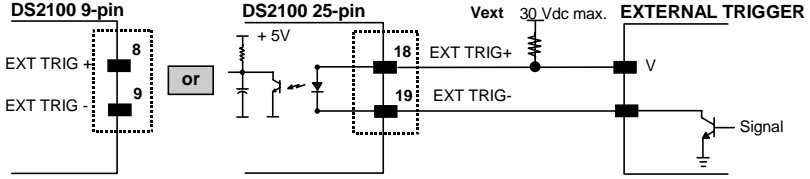

Figure 14 - Input NPN command using external power

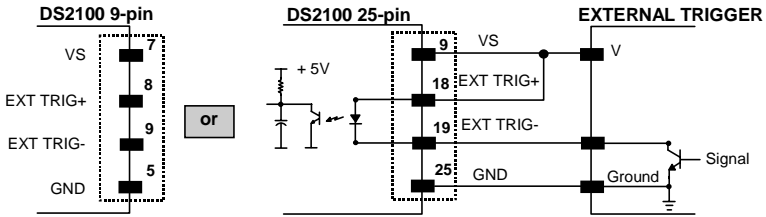

Figure 15 - Input NPN command using DS2100 power

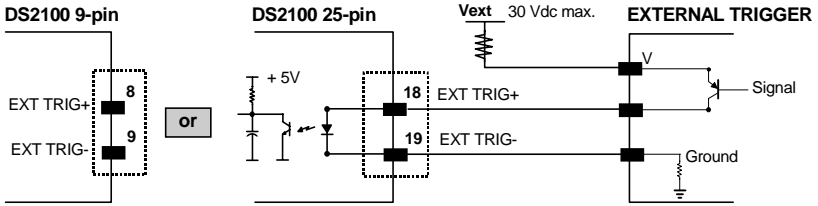

Figure 16 - Input PNP command using external power

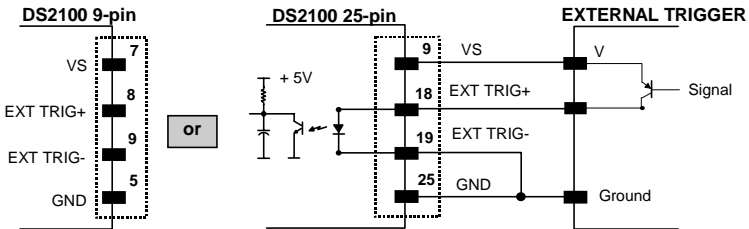

Figure 17 - Input PNP command using DS2100 power

**Electrical features:** Maximum voltage: 30 Vdc  
Maximum current: 25 mA

An anti-disturbance hardware filter is implemented on the External Trigger input (< 5 milliseconds delay).

An additional 15 ms (typical) delay can be implemented through a dedicated software parameter (refer to WinHost Help On Line).

### 2.3.5 Outputs

Two general purpose outputs are available which can be connected only in open collector configurations. The outputs are available only on 25-pin connector models. The following pins are present on the 25-pin connector of the scanner:

Connector 25-Pin	Name	Function
8	OUT1+	output 1 +
11	OUT2+	output 2 +
12, 22	OUT REF	output reference

The meaning of the two outputs OUT1 and OUT2 can be defined by the user (No Read, Right or Wrong). Refer to the WinHost Help On Line.

By default, OUT1 is associated with the No Read event, which activates when the code signaled by the external trigger is not decoded, and OUT2 is associated with the Right event, which activates when the code is correctly decoded.

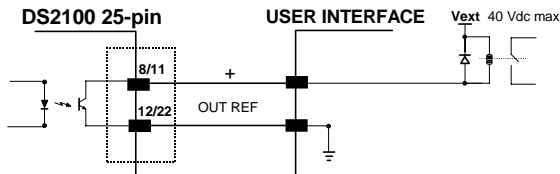

Figure 18 - Output open collector connections

These outputs are both level or pulse configurable.

## 2.4 POSITIONING

The DS2100 scanner is able to decode barcode labels at a variety of angles, however significant angular distortion may degrade reading performance.

When mounting the DS2100 take into consideration these three ideal label position angles: **Pitch 0°**, **Skew 10° to 30°** and **Tilt 0°**.

Follow the suggestions for the best orientation:

The **Pitch** angle is represented by the value **P** in Figure 19. Position the reader in order to **minimize** the **Pitch** angle.

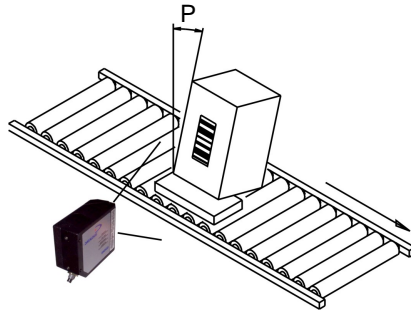

Figure 19 - Pitch Angle

The **Skew** angle is represented by the value **S** in Figure 20. Position the reader to **assure at least 10°** for the **Skew** angle. This avoids the direct reflection of the laser light emitted by the DS2100.

For the raster version, this angle refers to the most inclined or external raster line, so that all other raster lines assure **more** than 10° Skew.

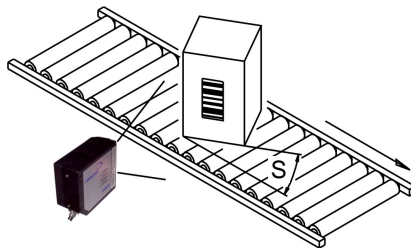

Figure 20 - Skew angle

The **Tilt** angle is represented by the value **T** in Figure 21. Position the reader in order to **minimize** the **Tilt** angle.

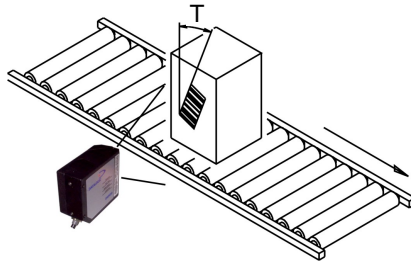

Figure 21 - Tilt angle

## 2.5 TYPICAL LAYOUTS

The following typical layouts refer to system hardware configurations. Dotted lines in the figures refer to optional hardware configurations within the particular layout.

These layouts also require the correct setup of the software configuration parameters. Complete software configuration procedures can be found in the **Guide To Rapid Configuration** in the WinHost Help On Line.



### 2.5.1 Point-to-Point

In this layout the data is transmitted to the Host on the main serial interface. Host Mode programming can be accomplished either through the main interface or the Auxiliary interface.

In Local Echo communication mode, data is transmitted on the RS232 auxiliary interface independently from the main interface selection.

When On-Line Operating mode is used, the scanner is activated by an External Trigger (photoelectric sensor) when the object enters its reading zone.

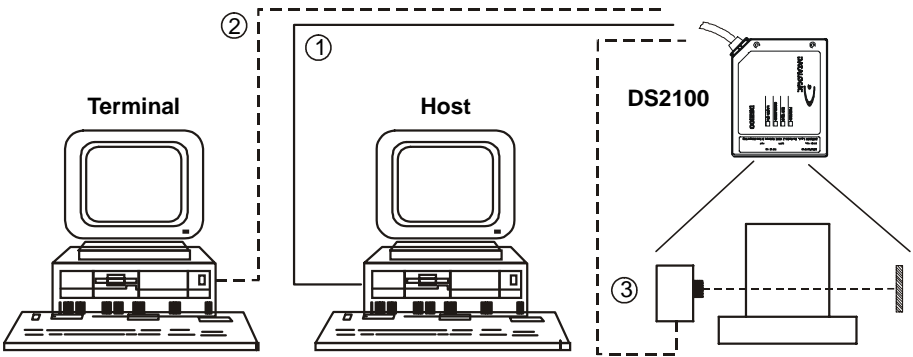

- ① Main serial interface
- ② Auxiliary serial interface (Local Echo)
- ③ External Trigger (for On-Line mode)

**Figure 22 – Point-to-point layout**

This is the only layout available for DS2100-X3XX models.

## 2.5.2 Pass-Through

Pass-through mode allows two or more devices to be connected to a single external serial interface.

Each DS2100 transmits the messages received by the Auxiliary interface onto the Main interface. All messages will be passed through this chain to the host.

When On-Line Operating mode is used, the scanner is activated by an External Trigger (photoelectric sensor) when the object enters its reading zone.

The Main and Auxiliary ports are connected as shown in the following figure:

- ① Main serial interface
- ② Auxiliary serial interface
- ③ External Trigger (for On-Line mode)

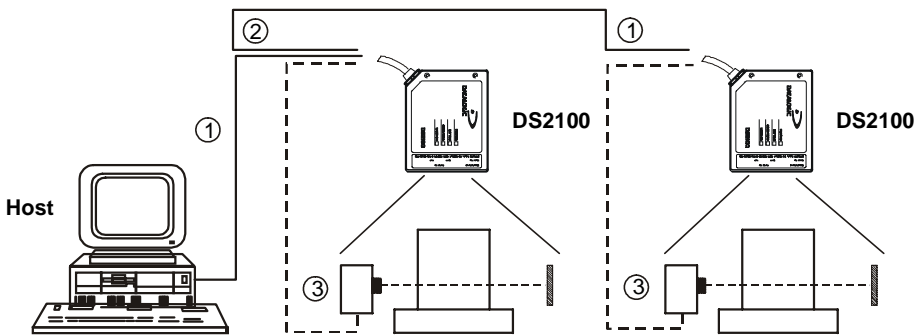

Figure 23 – Pass-through layout

### 2.5.3 RS232 Master/Slave

The RS232 master/slave connection is used to collect data from several scanners to build either a multi-point or a multi-sided reading system; there can be one master and up to 9 slaves connected together.

The Slave scanners use RS232 only on the main and auxiliary serial interfaces. Each slave DS2100 transmits the messages received by the auxiliary interface onto the main interface. All messages will be passed through this chain to the Master.

The Master scanner is connected to the Host on the main serial interface. The possible main interface types for the master scanner are RS232 or RS485.

There is a single reading phase and a single message from the master scanner to the Host computer.

Either On-Line or Serial On-Line Operating modes can be used in this layout.

**When On-Line Operating mode is used, the external trigger signal is unique to the system, however it is not necessary to bring the external trigger signal to the Slave scanners.**

The main and auxiliary ports are connected as shown in the figure below.

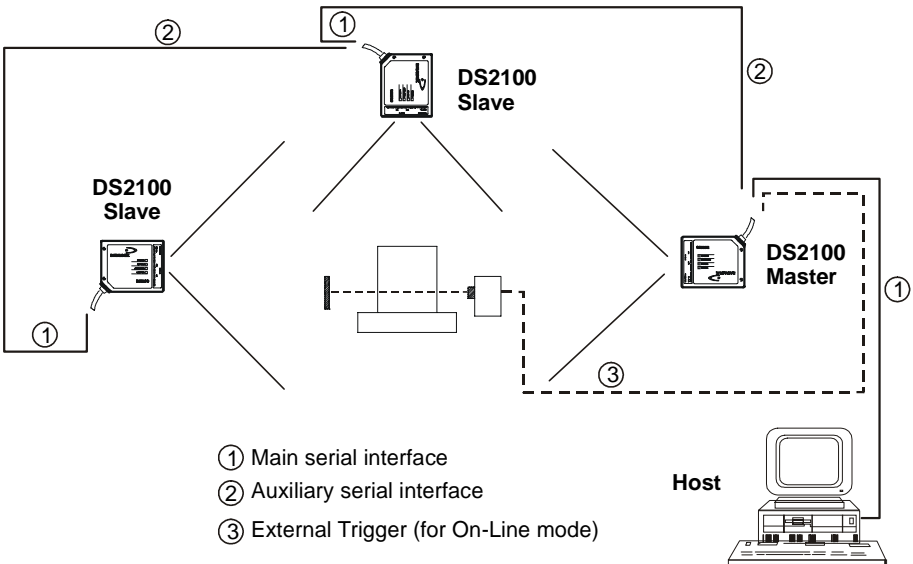

Figure 24 – RS232 Master/slave layout

## 2.5.4 RS485 Master/Slave

The RS485 master/slave connection is used to collect data from several scanners to build a multi-point or a multi-sided reading system; there can be one master and up to 5 slaves connected together.

The slave scanners are connected together using RS485 half-duplex on the main serial interface. Every slave scanner must have a multidrop address in the range 0-4.

The master scanner is also connected to the Host on the RS232 auxiliary serial interface.

The External Trigger signal is unique to the system; there is a single reading phase and a single message from the master scanner to the Host computer.

**It is necessary to bring the External Trigger signal to all the scanners.**

The main and auxiliary ports are connected as shown in the figure below.

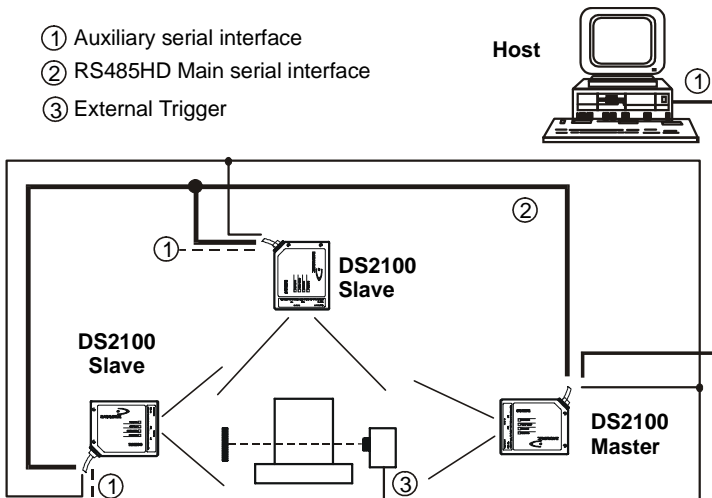

Figure 25 – RS485 Master/slave layout



**NOTE**

*The auxiliary serial interface of the slave scanners can be used in Local Echo communication mode to control any single scanner (visualize collected data) or to configure it using the WinHost utility or Host Mode programming procedure.*

*The termination resistors of the RS485 bus must not be installed.*

### 2.5.5 Multiplexer Layout

Each scanner is connected to a Multiplexer (for example MX4000) with the RS485 half-duplex main interface.

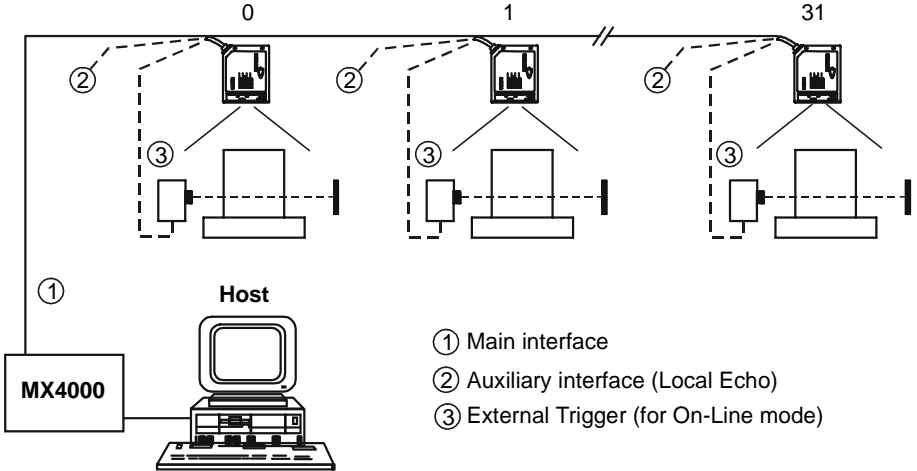

Figure 26 - Multiplexer layout

The auxiliary serial interface can be used in Local Echo mode to control any single scanner (visualize collected data) or to configure it using the WinHost utility or Host Mode programming procedure.

When On-Line Operating mode is used, the scanner is activated by an External Trigger (photoelectric sensor) when the object enters its reading zone.

## 3 READING FEATURES

The number of scans performed on the code by the DS2100 and therefore the decoding capability is influenced by the following parameters:

- number of scans per second
- code motion speed
- label dimensions
- scan direction with respect to code motion

At least 5 scans during the code passage should be allowed to ensure a successful read.

### 3.1 STEP-LADDER MODE

If scanning is perpendicular to the code motion direction (Figure 27), the number of effective scans performed by the reader is given by the following formula:

$$SN = [(LH/LS) * SS] - 2$$

Where: SN = number of effective scans  
 LH = label height (in mm)  
 LS = label movement speed in (mm/s)  
 SS = number of scans per second

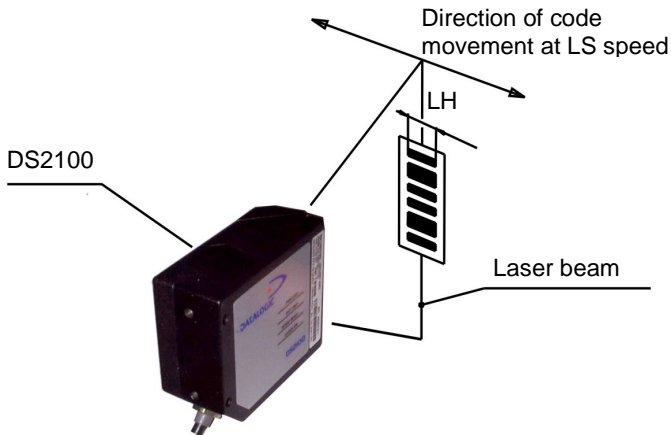

Figure 27 - "Step-Ladder" scanning mode

For example, the DS2100 (350 scans/sec.) for a 25 mm high code moving at 500 mm/s performs:

$$[(25/500) * 350] - 2 = 15 \text{ effective scans.}$$

### 3.2 PICKET-FENCE MODE

If scanning is parallel to the code motion, (Figure 28), the number of effective scans is given by the following formula:

$$SN = [((FW-LW)/LS) * SS] - 2$$

- Where: SN = number of effective scans  
 FW = reading field width (in mm)  
 LW = label width (in mm)  
 LS = label movement speed (in mm/s)  
 SS = scans per second

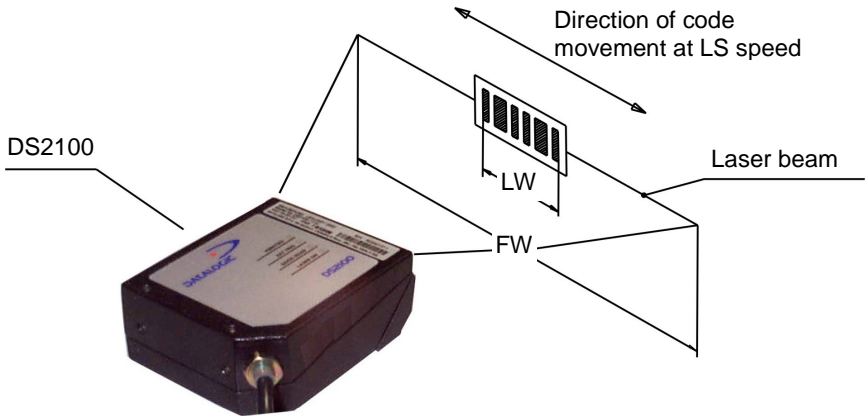

Figure 28 - "Picket-Fence" scanning mode

For example, for a 50 mm wide code moving in a point where the reading field is 200 mm wide at a 1500 mm/s speed, the DS2100 (350 scans per sec.), performs:

$$[((200-50)/1500) * 350] - 2 = 33 \text{ scans}$$

### 3.3 PERFORMANCE

The DS2100 scanner is available in different versions according to the reading performance.

Version	Max Code Resolution	Speed
	mm (mils)	scans/s
1XX0	0.20 (8)	350
1XX4	0.20 (8)	800
2XX0	0.15 (6)	350
2XX4	0.12 (5)	600

Version	Reading Distance
1XX0	40 mm (1.6 in) - 300 mm (11.8 in) on 0.50 mm (20 mils) codes
1XX4	45 mm (1.8 in) - 300 mm (11.8 in) on 0.50 mm (20 mils) codes
2XX0	30 mm (1.2 in) - 90 mm (3.5 in) on 0.30 mm (12 mils) codes
2XX4	45 mm (1.8 in) - 100 mm (3.9 in) on 0.20 mm (8 mils) codes

Refer to the diagrams given in par. 3.4 for further details on the reading features. They are taken on various resolution sample codes at a 25 °C ambient temperature, depending on the conditions in the notes under the diagrams.

#### 3.3.1 Raster

Raster versions are available. If standard devices do not satisfy specific requirements, contact your nearest Datalogic distributor, supplying code samples, to obtain complete information on the reading possibilities.

The max. capture of the Raster version is 18 mm (0.7 in) at 300 mm (11.8 in).



### 3.4 READING DIAGRAMS

#### DS2100-1XX0 (Standard Resolution, 350 scans/s)

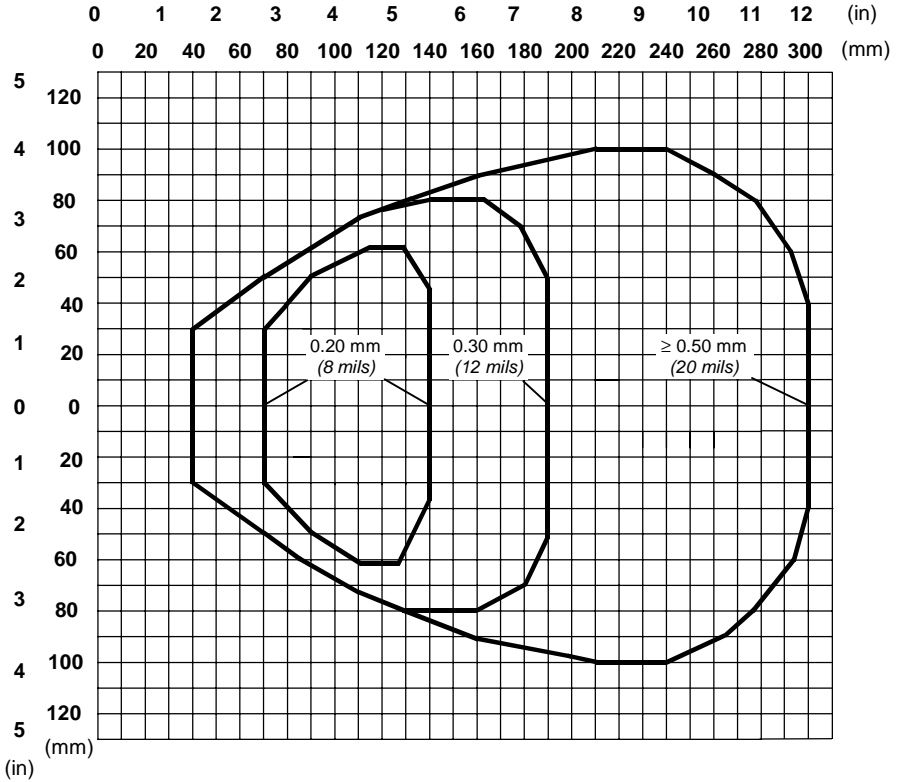

**NOTE:** (0,0) is the center of the laser beam output window.

#### CONDITIONS

- Code = Interleaved 2/5 or Code 39
- PCS = 0.90
- "Pitch" angle = 0°
- "Skew" angle = 10°
- "Tilt" angle = 0°

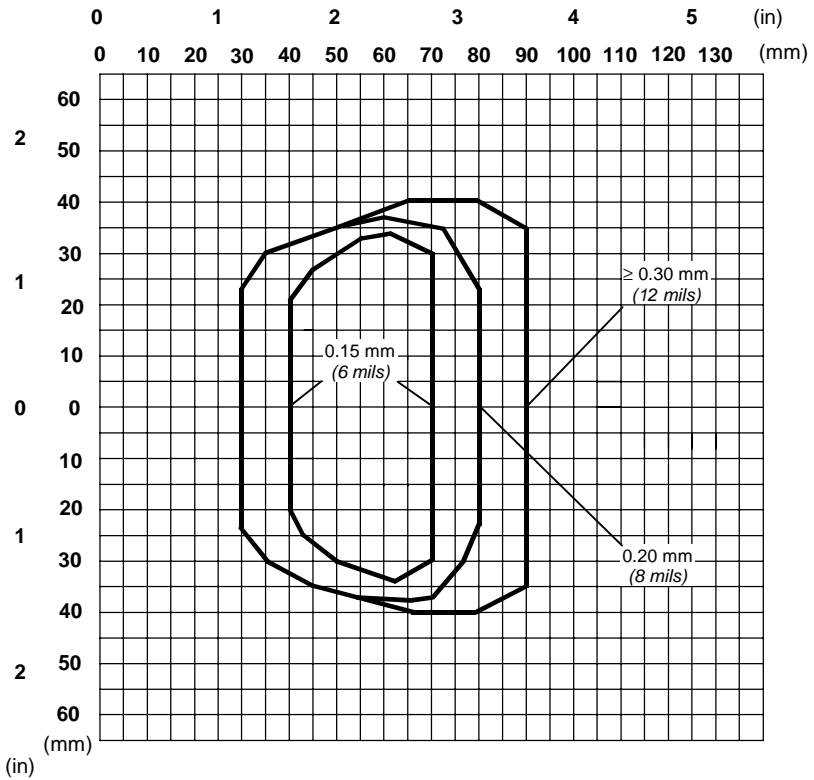
**DS2100-2XX0** (High resolution, 350 scans/s)

**NOTE:** (0,0) is the center of the laser beam output window.

**CONDITIONS**

Code	=	Interleaved 2/5 or Code 39
PCS	=	0.90
"Pitch" angle	=	0°
"Skew" angle	=	10°
"Tilt" angle	=	0°

**DS2100-1XX4** *Testarossa™*

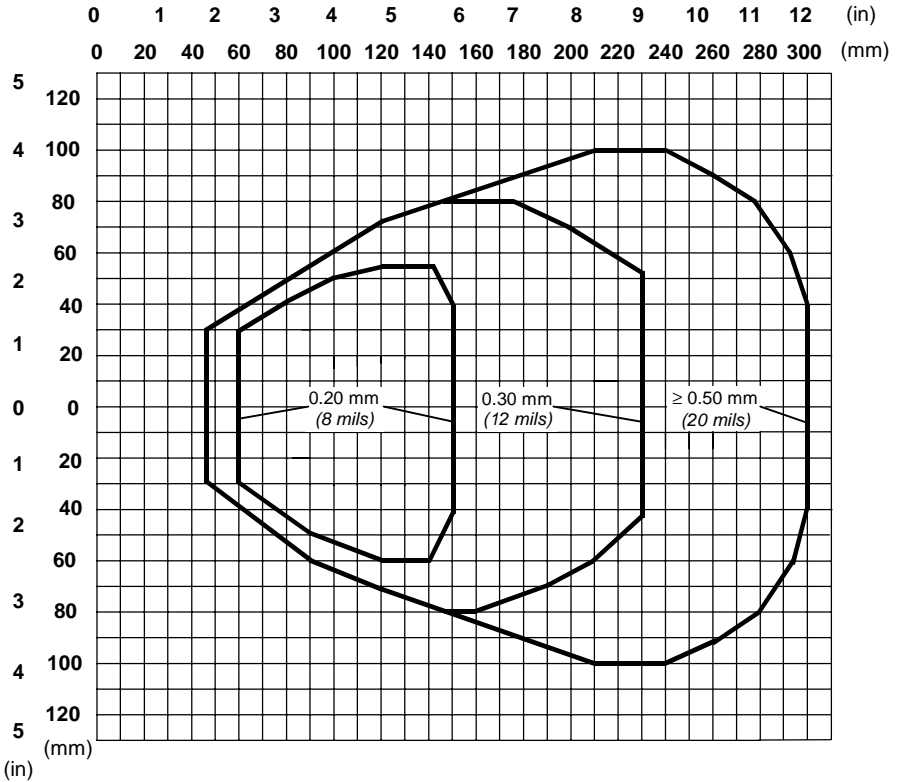

**NOTE:** (0,0) is the center of the laser beam output window.

**CONDITIONS**

- Code = Interleaved 2/5 or Code 39
- PCS = 0.90
- "Pitch" angle = 0°
- "Skew" angle = 10°
- "Tilt" angle = 0°
- Code Resolution\* = High – for 0.20 mm (8 mils) codes and 0.30 mm, (12 mils) codes  
 Standard – for 0.50 mm (20 mils) codes and greater

\* Parameter selectable in WinHost.

## DS2100-2XX4 Testarossa™ - High Resolution

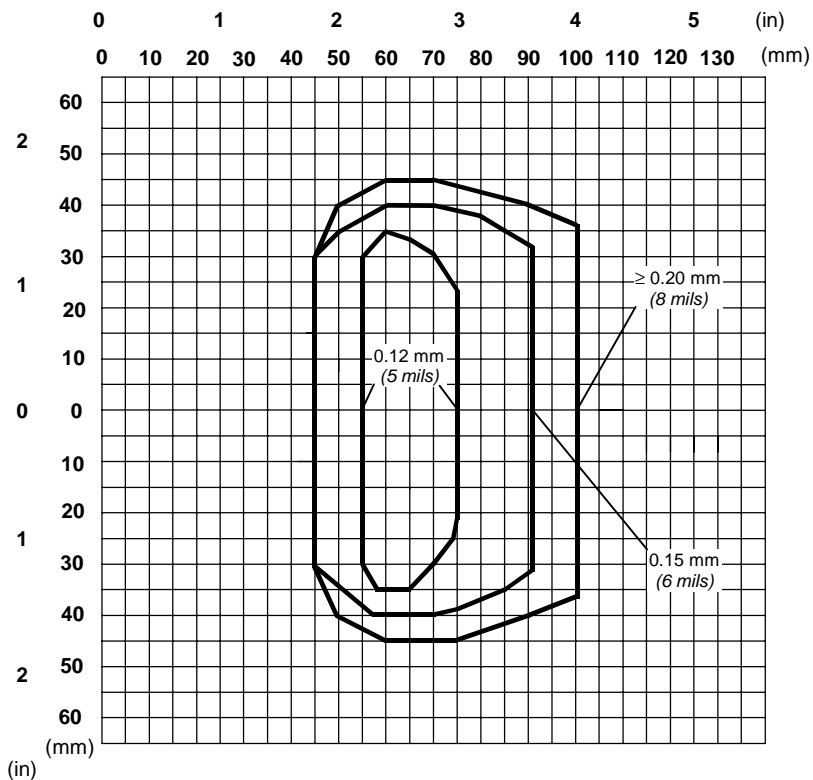

**NOTE:**(0,0) is the center of the laser beam output window.

### CONDITIONS

Code	=	Interleaved 2/5 or Code 39
PCS	=	0.90
"Pitch" angle	=	0°
"Skew" angle	=	10°
"Tilt" angle	=	0°
Code Resolution*	=	High      - for 0.12 mm (5 mils) codes Standard - for 0.15 mm (6 mils) codes and greater

\* Parameter selectable in WinHost.

## 4 MAINTENANCE

---

### 4.1 CLEANING

Clean the laser beam output window periodically for continued correct operation of the reader.

Dust, dirt, etc. on the window may alter the reading performance.

Repeat the operation frequently in particularly dirty environments.

Use soft material and alcohol to clean the window and avoid any abrasive substances.



**WARNING**

*Clean the window of the DS2100 when the scanner is turned off or, at least, when the laser beam is deactivated.*

## 5 TECHNICAL FEATURES

	DS2100-XXX0		DS2100-XXX4 <i>Testarossa</i> <sup>™</sup>	
	Standard Resolution	High Resolution	Standard Resolution	High Resolution
<b>ELECTRICAL FEATURES</b>				
<b>Power</b>				
Supply voltage	10 to 30 Vdc			
Power consumption max.	3 W		4 W	
<b>Serial Interfaces (depends on model)</b>				
Main	RS232; RS485 Full-duplex / Half-duplex; 20 mA C.L. (only with INT-22 accessory)			
Auxiliary	RS232			
Baud Rates	150 to 115200			
<b>Inputs</b>				
External Trigger	(optocoupled NPN or PNP)			
Voltage max.	30 Vdc			
Input current max.	25 mA			
<b>Outputs (except X3X0 models)</b>				
OUT1, OUT2	(optocoupled)			
V <sub>CE</sub> max.	40 Vdc			
Collector current max.	40 mA continuous; 130 mA pulsed			
V <sub>CE</sub> saturation	1V at 10 mA max.			
Power dissipation max.	90 mW at 40 °C (Ambient temp.)			
<b>OPTICAL FEATURES</b>				
Light source	Semiconductor laser diode			
Wave length (Note 1)	630 to 680 nm			
Ambient light immunity			Complete immunity	
Safety class	Class 2 - IEC 825-1; Class II - CDRH			
<b>READING FEATURES (Note 2)</b>				
Scan rate	350 scans/sec.		800 scans/sec.	600 scans/sec.
Reading distance	see diagrams in par. 3.4			
Maximum resolution mm (mils)	0.20 (8)	0.15 (6)	0.20 (8)	0.12 (5)
Aperture angle	60°			
<b>USER INTERFACE</b>				
LED indicators	Laser On, Good Read, External Trigger, Data TX / Power On			

<b>SOFTWARE FEATURES</b>	
<b>READABLE CODE SYMBOLOGIES</b>	
<ul style="list-style-type: none"> <li>• EAN/UPC (including Add-on 2 and Add-on 5)</li> <li>• 2/5 Interleaved</li> <li>• Code 39 (Standard and Full ASCII)</li> <li>• Codabar</li> <li>• Code 93</li> <li>• Code 128</li> <li>• EAN 128</li> <li>• Pharmacode</li> </ul> <p>Other symbologies available on request.</p>	
<b>Code Selection</b>	up to six different codes during one reading phase
<b>Decoding Safety</b>	can enable multiple good reads of same code
<b>Headers and Terminators</b>	up to four headers and four terminators
<b>Operating Modes</b>	On-Line, Automatic, Serial-On-Line, Test
<b>Configuration Modes</b>	<ul style="list-style-type: none"> <li>• through menus using WinHost utility</li> <li>• receiving commands from one of the serial ports (HOST MODE)</li> </ul>
<b>Parameter Storage</b>	Non-volatile internal EEPROM
<b>ENVIRONMENTAL FEATURES</b>	
Operating temperature (Note 3)	0° to 40 °C (32° to 104 °F)
Storage temperature	-20° to 70 °C (-4° to 158 °F)
Humidity max.	90% non condensing
Vibration resistance	IEC 68-2-6 test FC 1.5 mm; 10 to 55 Hz; 2 hours on each axis
Shock resistance	IEC 68-2-27 test EA 30G; 11 ms; 3 shocks on each axis
Protection class	IP65
<b>PHYSICAL FEATURES</b>	
Mechanical dimensions	68 x 84 x 34 mm (2.68 x 3.3 x 1.3 in)
Weight	300 g. (10.6 oz)

**Note 1:** The features given are typical at a 25 °C ambient temperature (if not otherwise indicated).

**Note 2:** Further details given in par. 3.3.

**Note 3:** If the reader is used in high temperature environments (over 35 °C), use of the Beam-shutter is advised (see the WinHost configuration program).

We

**Datalogic S.p.A.**  
**Via Candini, 2**  
**40012 - Lippo di Calderara**  
**Bologna - Italy**

declare under our sole responsibility that the product

**DS2100-XXXX, Laser Scanner and all its models**

to which this declaration relates is in conformity with the following standards or other normative documents

**EN 55022, August 1994:** LIMITS AND METHODS OF MEASUREMENTS OF RADIO DISTURBANCE CHARACTERISTICS OF INFORMATION TECHNOLOGY EQUIPMENT (ITE)

**EN 50082-2, March 1995:** ELECTROMAGNETIC COMPATIBILITY. GENERIC IMMUNITY STANDARD. PART 2: INDUSTRIAL ENVIRONMENT

Following the provision of the Directive(s):

**89/336 CEE AND SUCCESSIVE AMENDMENTS, 92/31 CEE; 93/68 CEE**

Lippo di Calderara, 29.01.1998

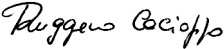
Ruggero Cacioppo  
  
Quality Assurance Supervisor