



Allen-Bradley

*AdaptaScan
Bar Code
Readers*

*(Cat. Nos. 2755-SN3, -SN5, and
-SN8)*



Application Guide

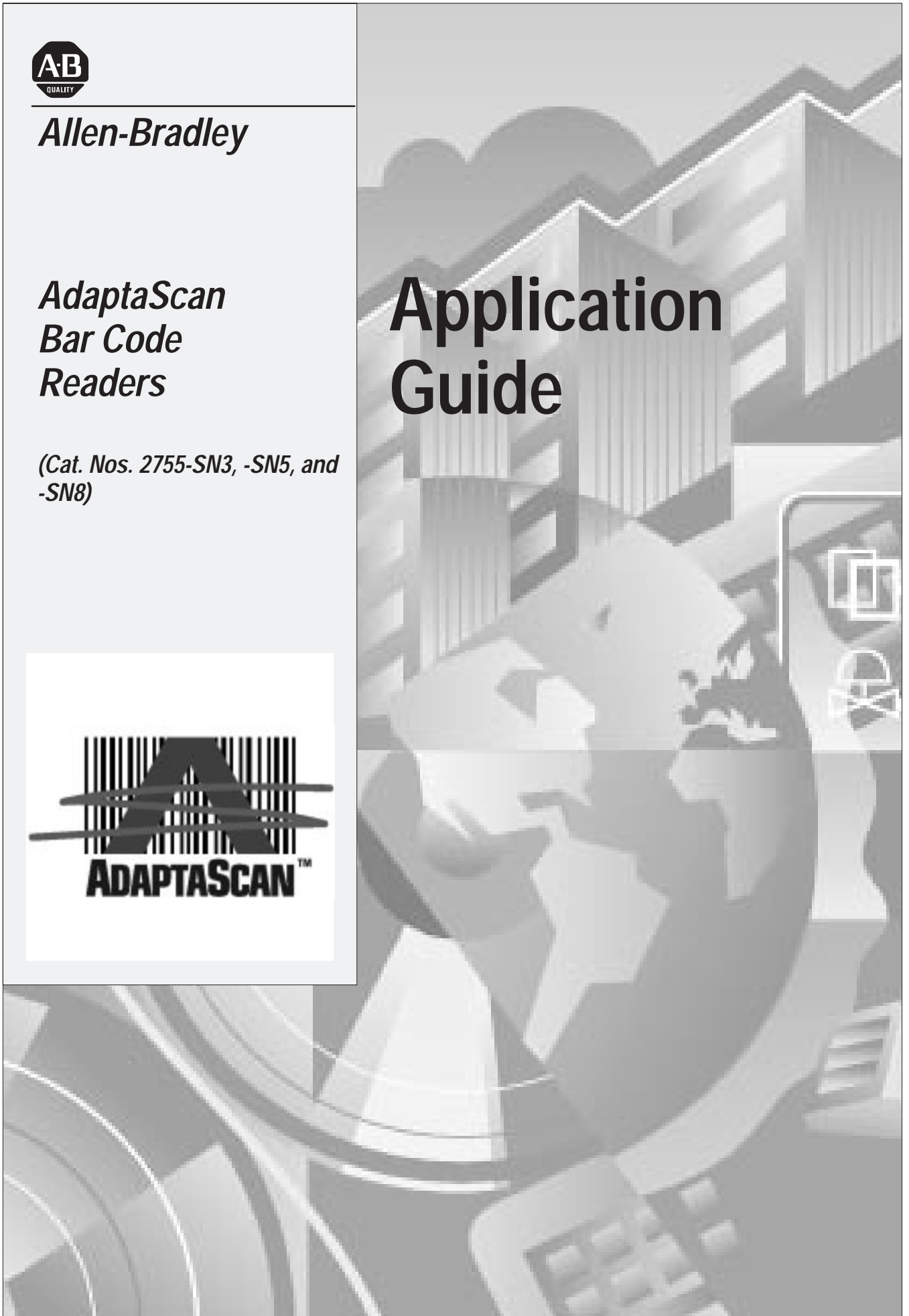

Important User Information

Because of the variety of uses for the products described in this publication, those responsible for the application and use of this control equipment must satisfy themselves that all necessary steps have been taken to assure that each application and use meets all performance and safety requirements, including any applicable laws, regulations, codes and standards.

The illustrations, charts, sample programs and layout examples shown in this guide are intended solely for purposes of example. Since there are many variables and requirements associated with any particular installation, Allen-Bradley does not assume responsibility or liability (to include intellectual property liability) for actual use based upon the examples shown in this publication.

Allen-Bradley publication SGI-1.1, *Safety Guidelines for the Application, Installation, and Maintenance of Solid-State Control* (available from your local Allen-Bradley office), describes some important differences between solid-state equipment and electromechanical devices that should be taken into consideration when applying products such as those described in this publication.

Reproduction of the contents of this copyrighted publication, in whole or in part, without written permission of Allen-Bradley Company, Inc., is prohibited.

Throughout this manual we use notes to make you aware of safety considerations:



ATTENTION: Identifies information about practices or circumstances that can lead to personal injury or death, property damage or economic loss.

Attention statements help you to:

- identify a hazard
- avoid the hazard
- recognize the consequences

Important: Identifies information that is critical for successful application and understanding of the product.

Table of Contents

	Preface	
	Contents of this Guide	P-2
	Intended Audience	P-4
	Related Publications	P-4
	Technical Support Services	P-4
Using the Auto-Load Function	Chapter 1	
	Overview	1-1
	Hardware Requirements	1-1
	Software Requirements	1-1
	Related Publications	1-1
	Internal Power Source	1-2
	Connecting a Power Supply to the Reader	1-2
	Configuring the Reader	1-3
	Create a New Project	1-3
	Define a Bar Code Label	1-4
	Define the DeviceNet Address	1-5
	Configure the Scanner	1-5
	Configure the Decoder	1-6
	Configure the Discrete Input Module	1-6
	Configure the Match Table	1-7
	Configure a Package	1-8
	Configure the Auto-Load Trigger Source	1-9
	Sending the Configuration to the Reader	1-10
	Running the Application	1-10
Using ASCII Command Input	Chapter 2	
	Overview	2-1
	Hardware Requirements	2-1
	Software Requirements	2-1
	Related Publications	2-1
	Connecting a Computer to the Reader	2-2
	Connecting a Power Supply to the Reader	2-2
	Configuring the Reader	2-3
	Create a New Project	2-3
	Define the Bar Code Label	2-4
	Define the DeviceNet Address	2-5
	Configure the Scanner	2-5
	Configure the Decoder Trigger	2-6
	Configure the ASCII Commands	2-6
	Configure the Serial Port	2-8

	Create a Message	2-10
	Define the Message Format	2-11
	Sending the Configuration to the Reader	2-12
	Running the Application	2-12
Downloading Match Codes from a Host Device	Chapter 3	
	Overview	3-1
	Hardware Requirements	3-1
	Software Requirements	3-1
	Related Publications	3-1
	Connecting a Computer to the Reader	3-2
	Connecting a Power Supply to the Reader	3-2
	Configuring the Reader	3-3
	Create a New Project	3-3
	Define the Bar Code Label	3-4
	Define the DeviceNet Address	3-5
	Configure the Scanner	3-5
	Configure the Decoder Trigger	3-6
	Configure the Serial Port	3-7
	Configuring a Match Entry and I/O Indicator LED	3-8
	Sending the Configuration to the Reader	3-9
	Finding Match Table Instances	3-10
	Connecting the Computer to the RS-232 Port	3-10
	Downloading Match Codes	3-11
	Convert the Bar Code String to Hex	3-11
	Place the String in the Data Packet	3-11
	Send Data to the Reader	3-12
	Response Codes	3-14
	Downloading Other Host Commands	3-15
Downloading Match Codes via DH485 Protocol with an SLC 5/03 or SLC 5/04 Controller	Chapter 4	
	Overview	4-1
	Hardware Requirements	4-1
	Software Requirements	4-1
	Related Publications	4-2
	Connecting a Power Supply to the Reader	4-2
	Connecting to the DH-485 Network	4-2
	Connecting Readers to SLC 5/03 Controller	4-3
	Connecting Readers to SLC 5/04 Controller – 2 AIC Modules	4-4
	Connecting Readers to SLC 5/04 Controller – 1 AIC Module	4-5
	Configuring Bar Code Reader 1	4-6
	Create a New Project	4-6
	Define the Bar Code Label	4-7
	Define the DeviceNet Address	4-8
	Configure the Scanner	4-9

Configure the Decoder Trigger	4-9
Configure the Serial Port	4-10
Configure for Match Codes	4-13
Configure for a Package	4-14
Configure for an Output	4-15
Sending the Configuration to the Reader	4-16
Finding Match Table Instances	4-16
Downloading Match Codes	4-17
Convert the Bar Code String to Hex	4-17
Place the String in the Data Packet	4-17
Response Codes	4-19
Configuring the SLC Controller	4-20
SLC 5/04 Configuration	4-20
SLC Ladder Logic	4-21
Viewing Match Codes in Slave Mode via the Reader's LEDs	4-21
Viewing Match Code Downloads in Slave Mode via Ladder Logic	4-22
Viewing Match Code Downloads in Master Mode via Ladder Logic	4-25

**Communicating with a
1746-BAS BASIC Module**

Chapter 5

Overview	5-1
Hardware Requirements	5-1
Software Requirements	5-1
Related Publications	5-1
Connecting a BASIC Module to the Reader	5-2
SLC Ladder Logic	5-3
Programming the BASIC Module	5-4
SLC BASIC Module Code	5-5
Configuring the Reader	5-5
Create a New Project	5-5
Define the Bar Code Label	5-7
Define the DeviceNet Address	5-8
Configure the Scanner	5-9
Configure the Decoder Trigger	5-10
Configure the Serial Port	5-10
Create a Message	5-11
Define the Message Format	5-12
Sending the Configuration to the Reader	5-13
Running the Application	5-13

**Communicating with an SLC
over an RS-232 Link**

Chapter 6

Overview	6-1
Hardware Requirements	6-1
Software Requirements	6-1
Related Publications	6-1

Connecting an SLC Controller to the Reader	6-2
Configuring the SLC Controller	6-2
SLC Ladder Logic Program	6-3
Configuring the Reader	6-4
Create a New Project	6-4
Define the Bar Code Label	6-5
Define the DeviceNet Address	6-6
Configure the Scanner	6-7
Configure the Decoder Trigger	6-7
Configure the Serial Port	6-8
Create a Message	6-9
Define the Message Format	6-10
Sending the Configuration to the Reader	6-11
Running the Application	6-11

Communicating with an SLC on a DH-485 Network

Chapter 7

Overview	7-1
Hardware Requirements	7-1
Software Requirements	7-1
Related Publications	7-2
Connecting a Power Supply to the Reader	7-3
Connecting to the DH-485 Network	7-3
Connecting Readers to SLC 5/03 Controller	7-4
Connecting Readers to SLC 5/04 Controller – 2 AIC Modules ...	7-5
Connecting Readers to SLC 5/04 Controller – 1 AIC Module	7-6
Configuring the SLC Controller	7-7
SLC 5/04 Configuration	7-7
Configuring Bar Code Reader 1	7-8
Create a New Project	7-8
Define the Bar Code Label	7-9
Define the DeviceNet Address	7-10
Configure the Scanner	7-11
Configure the Decoder Trigger	7-12
Configure the Serial Port	7-12
Create a Message	7-14
Define the Message Format	7-15
Sending the Configuration to Reader 1	7-16
Configuring Bar Code Reader 2	7-16
Add a Second Bar Code Reader to the Project	7-16
Define the DeviceNet Address	7-16
Define the Bar Code Label	7-17
Configure the Scanner	7-18
Configure the Decoder Trigger	7-18
Configure the Serial Port	7-19
Create a Message	7-20

Define the Message Format	7-21
Sending the Configuration to Reader 2	7-22
Running the Application	7-22

**Communicating with a PLC-5
over an RS-232 or RS-422
Link**

Chapter 8

Overview	8-1
Hardware Requirements	8-1
Software Requirements	8-1
Related Publications	8-1
Connecting the PLC-5 Processor to the Reader	8-2
Cabling	8-2
Configuring the PLC Processor	8-3
PLC-5 Ladder Logic Program	8-4
Configuring the Reader	8-5
Create a New Project	8-5
Define the Bar Code Label	8-6
Define the DeviceNet Address	8-7
Configure the Scanner	8-8
Configure the Decoder Trigger	8-8
Configure the Serial Port	8-9
Create a Message	8-10
Define the Message Format	8-11
Sending the Configuration to the Reader	8-12
Running the Application	8-12

**Communicating with an SLC
5/03 Processor on a
DeviceNet Network**

Chapter 9

Overview	9-1
Hardware Requirements	9-1
Software Requirements	9-1
Related Publications	9-2
Connecting to the DeviceNet Network	9-2
Connecting a Power Supply to the Reader	9-2
SLC Ladder Logic	9-3
Message Addressing	9-3
Message Flow Control	9-4
N23 Data Table File Monitor	9-6
N22 Data Table File Monitor	9-6
Data Table File 0 Monitor	9-7
Data Table File M1 Monitor	9-7
Configuring the DeviceNet Scanner	9-8
Configuring the Reader	9-13
Create a New Project	9-13
Change the Baud Rate	9-14
Define the Bar Code Label	9-15
Define the DeviceNet Address	9-16

Configure the Scanner	9-16
Configure the Decoder Trigger	9-17
Create a Message	9-17
Define the Message Format	9-19
Sending the Configuration to the Reader	9-19
Running the Application	9-19
Troubleshooting the Module and Network	9-20

Communicating with an SLC 5/03 Processor on a DeviceNet Network using Explicit Messaging

Chapter 10

Overview	10-1
Hardware Requirements	10-1
Software Requirements	10-1
Related Publications	10-2
Connecting to the DeviceNet Network	10-2
Connecting a Power Supply to the Reader	10-2
SLC Ladder Logic	10-3
Message Addressing	10-3
Message Flow Control	10-4
N23 Data Table File Monitor	10-6
N22 Data Table File Monitor	10-6
Data Table File 0 Monitor	10-7
Data Table File M1 Monitor	10-7
Configuring the DeviceNet Scanner	10-8
Configuring the Reader	10-13
Create a New Project	10-13
Change the Baud Rate	10-14
Define the Bar Code Label	10-15
Define the DeviceNet Address	10-16
Configure the Scanner	10-16
Configure the Decoder Trigger	10-17
Create a Message	10-17
Define the Message Format	10-19
Configure for Match Codes	10-20
Configure for a Package	10-22
Configure for an Output	10-23
Sending the Configuration to the Reader	10-23
Running the Application	10-23
Explicit Message Program Control	10-24
Explicit Message Program Control Feature	10-25
Formatting the Explicit Message Transaction Block	10-26
Processor and Scanner Module Manage Messages	10-28
Explicit Message Program Control Limitations	10-29
Explicit Messaging Ladder Logic Program	10-31
Example Data Tables	10-31
Notes on using Explicit Messaging	10-32

Troubleshooting the Module and Network 10-33
 Downloading Other Host Commands 10-36

Communicating with a PLC-5 Processor on a DeviceNet Network

Chapter 11

Overview 11-1
 Hardware Requirements 11-1
 Software Requirements 11-1
 Related Publications 11-2
 Connecting to the DeviceNet Network 11-2
 Connecting a Power Supply to the Reader 11-2
 PLC Ladder Logic 11-3
 Message Addressing 11-3
 Message Flow Control 11-4
 Data Table File N23 Monitor 11-6
 Data Table File N22 Monitor 11-6
 Configuring the DeviceNet Scanner 11-7
 Configuring the Reader 11-12
 Create a New Project 11-12
 Change the Baud Rate 11-13
 Define the Bar Code Label 11-14
 Define the DeviceNet Address 11-15
 Configure the Scanner 11-15
 Configure the Decoder Trigger 11-16
 Create a Message 11-16
 Define the Message Format 11-18
 Sending the Configuration to the Reader 11-18
 Running the Application 11-18
 Troubleshooting Your Module 11-19

Communicating with a PLC-5 Processor on a DeviceNet Network using Explicit Messaging

Chapter 12

Overview 12-1
 Hardware Requirements 12-1
 Software Requirements 12-1
 Related Publications 12-2
 Connecting to the DeviceNet Network 12-2
 Connecting a Power Supply to the Reader 12-2
 PLC Ladder Logic 12-3
 Message Addressing 12-3
 Message Flow Control 12-4
 Data Table File N23 Monitor 12-6
 Data Table File N22 Monitor 12-6
 Configuring the DeviceNet Scanner 12-7
 Configuring the Reader 12-12
 Create a New Project 12-12
 Change the Baud Rate 12-13

Define the Bar Code Label	12-14
Define the DeviceNet Address	12-15
Configure the Scanner	12-15
Configure the Decoder Trigger	12-16
Create a Message	12-16
Define the Message Format	12-18
Sending the Configuration to the Reader	12-18
Running the Application	12-18
Explicit Message Program Control	12-19
Explicit Message Program Control Feature	12-20
Formatting the Explicit Message Transaction Block	12-21
How the Processor and Scanner Module Manage Messages	12-23
Explicit Message Program Control Limitations	12-24
Explicit Messaging Ladder Logic Program	12-26
Example Data Tables	12-26
Notes on using Explicit Messaging	12-27
Troubleshooting Your Module	12-28
Downloading Other Host Commands	12-31

**Communicating with a
2760-RB Module over an
RS-232 Link**

Chapter 13

Overview	13-1
Hardware Requirements	13-1
Software Requirements	13-1
Related Publications	13-2
PLC-5 Compatibility	13-2
Connecting the RB Module to the Reader	13-2
Classic PLC-5 Processor DIP Switches	13-3
Enhanced PLC-5 Processor DIP Switches	13-3
I/O Chassis Backplane DIP Switches	13-3
2760-RB Module DIP Switches	13-3
Cabling	13-5
Configuring the PLC-5 Processor	13-6
Using the 2760-RB Module, Revision H or Above, with the New Generation PLC-5 Processor	13-7
Configuring the 2760-RB Interface Module	13-7
Configuring the Reader	13-10
Create a New Project	13-10
Define the Bar Code Label	13-11
Define the DeviceNet Address	13-12
Configure the Scanner	13-13
Configure the Decoder Trigger	13-13
Configure the Serial Port	13-14
Create a Message	13-15
Sending the Configuration to the Reader	13-16

**Communicating with a
2760-RB Module on a DH-485
Network****Chapter 14**

Overview	14-1
Hardware Requirements	14-1
Software Requirements	14-1
Related Publications	14-1
PLC-5 Compatibility	14-2
Connecting the RB Module to the Reader	14-2
Classic PLC-5 Processor DIP Switches	14-2
Enhanced PLC-5 Processor DIP Switches	14-3
I/O Chassis Backplane DIP Switches	14-3
2760-RB Module DIP Switches	14-3
Cabling	14-4
Configuring the PLC-5 Processor	14-5
Using the 2760-RB Module, Revision H or Above, with the New Generation PLC-5 Processor	14-6
Configuring the 2760-RB Interface Module	14-6
Configuring the Bar Code Reader	14-8
Create a New Project	14-8
Define the Bar Code Label	14-9
Define the DeviceNet Address	14-10
Configure the Scanner	14-11
Configure the Decoder Trigger	14-12
Configure the Serial Port	14-12
Create a Message	14-14
Define the Message Format	14-15
Sending the Configuration to the Reader	14-15

**Downloading Match Codes
via DH485 using a PLC-5
Processor and a 2760-RB
Module****Chapter 15**

Overview	15-1
Hardware Requirements	15-1
Software Requirements	15-1
Related Publications	15-1
PLC-5 Compatibility	15-2
Connecting the RB Module to the Reader	15-2
Classic PLC-5 Processor DIP Switches	15-2
Enhanced PLC-5 Processor DIP Switches	15-3
I/O Chassis Backplane DIP Switches	15-3
2760-RB Module DIP Switches	15-3
Cabling	15-4
Configuring the PLC-5 Processor	15-5
Using the 2760-RB Module, Revision H or Above, with the New Generation PLC-5 Processor	15-6
Configuring the 2760-RB Interface Module	15-6
Configuring the Bar Code Reader	15-8
Create a New Project	15-8

Define the Bar Code Label	15-9
Define the DeviceNet Address	15-10
Configure the Scanner	15-10
Configure the Decoder Trigger	15-11
Configure the Serial Port	15-12
Configure for Match Codes	15-13
Configure for a Package	15-14
Configure for an Output	15-15
Sending the Configuration to the Reader	15-15
Downloading Match Codes	15-16
PLC Command Files	15-16
Convert the Bar Code String to Hex	15-16
Place the String in the Data Packet	15-17
Match Code String in Block Transfer Write	15-17
Response Codes	15-18

Communicating with AdaptaScan Bar Code Readers via DeviceNet Peer-to-Peer Protocol

Chapter 16

Overview	16-1
Hardware Requirements	16-1
Software Requirement	16-1
Related Publications	16-1
Connecting to the DeviceNet Network	16-2
Connecting a Power Supply to a Reader	16-2
Multiple Reader Connections using Other Power Supply	16-3
Configuring Bar Code Reader 1	16-4
Create a New Project	16-4
Define the DeviceNet Address	16-5
Define the Bar Code Label	16-6
Configure the Scanner	16-7
Configure the Decoder Trigger	16-8
Configure the Serial Port	16-8
Create a Message	16-9
Define the Message Format	16-10
Configuring Bar Code Reader 2	16-11
Select Bar Code Reader 2 in the Project	16-11
Define the DeviceNet Address	16-11
Configure the Scanner	16-12
Configure the Decoder Trigger	16-12
Create a Message	16-13
Define the Message Format	16-14
Configuring Bar Code Reader 3	16-15
Selecting Bar Code Reader 3 in the Project	16-15
Define the DeviceNet Address	16-15
Configure the Scanner	16-16
Configure the Decoder Trigger	16-16

**Communicating with
PanelView 900 Terminals on
a DeviceNet Network**

Create a Message	16-17
Define the Message Format	16-18
Sending the Configurations to the Readers	16-19
Running the Application	16-19

Chapter 17

Introduction	17-1
Hardware Requirements	17-1
Software Requirements	17-1
Related Publications	17-2
DeviceNet PanelView Terminals	17-2
Typical DeviceNet Network	17-3
Making DeviceNet Connections	17-4
Making Serial Port Connections	17-5
Modifying DeviceNet Settings from the Terminal	17-6
Setting up Communications using PanelBuilder	17-8
Selecting a DeviceNet PanelView Terminal	17-8
Configuring DeviceNet Communications	17-9
PanelView Message Types	17-11
Server Explicit and I/O Slave Messaging	17-11
Client Explicit Messaging	17-12
PanelView Tag Editor	17-14
Using the Electronic Data Sheet	17-17
Downloading Applications over a Serial Link	17-18
Downloading Application using the Internal DF1 Driver	17-18
DeviceNet Application Report	17-19
Error Messages and Codes	17-19
PanelBuilder Tag Error Messages	17-19
PanelBuilder Device Error Messages	17-20
PanelBuilder Translation Error Messages	17-20
Electronic Data Sheet (EDS) File Error Messages	17-21
Communication Status Error Messages	17-22
Alert Messages	17-23
Fault Messages	17-24
AdaptaScan Application	17-25
Connections	17-25
PanelView Screen	17-26
Read Bar Code Data Tag Configuration	17-27
Read Package Counter Tag Configuration	17-28
Write Package Count Reset	17-29
AdaptaScan Configuration	17-30
Making Bar Code Data Available	17-30
Making Package Counter Data Available	17-31

Preface

This guide describes a variety of applications in which the AdaptaScan™ Bar Code Reader is used. Each chapter covers a separate application and provides:

- overview of the application
- hardware requirements
- software requirements

Each application shows how to:

- connect the AdaptaScan Reader to a network or host device
- configure the AdaptaScan Bar Code Reader
- configure the controller, providing the necessary ladder logic (if required)

Because of the variety of uses for the information, the user of and those responsible for applying this information must satisfy themselves as to the acceptability of each application and use of the program. In no event will Allen-Bradley Company be responsible or liable for indirect or consequential damages resulting from the use of application of this information.

The examples shown in this document are intended solely to illustrate the principles of the bar code reader and some of the methods used to apply them. Particularly because of the many requirements associated with any particular installation, Allen-Bradley Company cannot assume responsibility or liability for actual use based upon the illustrative uses and applications.

Contents of this Guide

The following table describes the contents of this manual.

Chapter	Title	Contents
	Preface	Describes the purpose, background, and scope of this guide. Also specifies the audience for whom this guide is intended.
1	Using the Auto-Load Function	Describes how to configure the reader to autoload data into the match code table.
2	Using ASCII Command Input	Shows how to configure the reader to start/stop scanning when receiving ASCII commands from a terminal emulator and then display the bar code data on the emulator.
3	Downloading Match Codes from a Host Device	Shows how to download match codes (and other host commands) from a terminal emulator to the reader.
4	Downloading Match Codes via DH485 Protocol with an SLC 5/03™ or SLC 5/04™ Controller	Shows how to download match codes from an SLC 5/03 or SLC 5/04 controller to the reader.
5	Communicating with a 1746-BAS BASIC Module	Describes how to configure the reader to communicate with a 1746-BAS BASIC module.
6	Communicating with an SLC™ over an RS-232 Link	Describes how to configure the reader to communicate with an SLC controller over an RS-232 serial connection.
7	Communicating with an SLC on a DH-485 Network	Tells how to configure two readers to communicate with an SLC controller over a DH-485 network using master mode.
8	Communicating with an PLC-5® over an RS-232 or RS-422 Link	Describes how to configure the reader to communicate with an PLC controller using either RS-232 or RS-422 communication.
9	Communicating with an SLC 5/03 Processor on a DeviceNet™ Network	Shows how to configure a reader to communicate with an SLC controller over a DeviceNet network in master/slave mode.
10	Communicating with an SLC 5/03 Processor on a DeviceNet Network using Explicit Messaging	Shows how to configure a reader to communicate with an SLC controller over a DeviceNet network in master/slave mode using explicit messaging.
11	Communicating with a PLC-5 Processor on a DeviceNet Network	Shows how to configure a reader to communicate with a PLC-5 controller over a DeviceNet network in master/slave mode.

Table continued on the next page.

Chapter	Title	Contents
12	Communicating with a PLC-5 Processor on a DeviceNet Network using Explicit Messaging	Shows how to configure a reader to communicate with a PLC-5 controller over a DeviceNet network in master/slave mode using explicit messaging.
13	Communicating with a 2760-RB Module over an RS-232 Link	Describes how to configure the reader to communicate with a 2760-RB module using RS-232 communication.
14	Communicating with a 2760-RB Module on a DH-485 Network	Describes how to configure the reader to communicate with a 2760-RB module using DH-485 communication.
15	Downloading Match Codes via DH485 using a PLC-5 Processor and a 2760-RB Module	Describes how to configure the reader to communicate with a PLC-5 processor via DH485 protocol, using a 2760-RB module.
16	Communicating with AdaptaScan Bar Code Readers via DeviceNet Peer-to-Peer Protocol	Describes how to configure three readers to communicate with each other over a DeviceNet network via peer-to-peer protocol.
17	Communicating with PanelView 900™ Terminals on a DeviceNet Network	Describes how to configure the reader to communicate with the DeviceNet versions of the PanelView 900 terminals.

Intended Audience

This application guide assumes that you understand how to:

- configure and operate the AdaptaScan Bar Code Reader using the AdaptaScan Software.
- program and operate the logic controller that will communicate with the reader
- configure the appropriate network communications

Related Publications

Publications that relate to the AdaptaScan Bar Code Readers and other Allen-Bradley products used with the readers are:

Publication Number	Description
2755-837	AdaptaScan Bar Code Reader User Manual
2755-838	AdaptaScan Software User Manual
1485-6.7.1	DeviceNet Cable System Planning and Installation Manual
1770-6.2.2	Data Highway / Data Highway Plus™ / Data Highway-485 Cable Installation Manual
1787-6.5.3	DeviceNet Manager Software (Catalog No. 1787-MGR) User Manual
1749-6.5.5	DeviceNet Adapter Module (Catalog No. 1749-ADN) User Manual
1747-6.5.2	DeviceNet Scanner (Catalog No. 1747-SDN) Configuration Manual
1771-6.5.118	DeviceNet Scanner (Catalog No. 1771-SDN) Configuration Manual

Each chapter refers to additional publications that relate to a specific application.

Technical Support Services

If you have any questions about the AdaptaScan Bar Code Reader, please consult this application guide first. If you can't find the answer, contact Rockwell Automation International Support:

Rockwell Automation
 Technical Support
 6680 Beta Drive
 Mayfield Village, Ohio 36849

Inside USA and Canada, call 1-800-289-2279.

Outside USA and Canada, contact your Allen-Bradley office or call USA (216) 646-6800.

Using the Auto-Load Function

Overview

This application describes how to set up the AdaptaScan Bar Code Reader to use the Auto-Load function. The application uses a PHOTOSWITCH[®] (Catalog No. 42SRU-6203) as a package detector to trigger the decoder and a discrete input to activate the Auto-Load.

Hardware Requirements

The hardware items required for this application are:

- 2755-SN3, -SN5 or -SN8 AdaptaScan Bar Code Reader
- 2755-NB40 or -NB41 Wiring Base
- 2755-PW46 or -PW47 Power Supply
- 2755-NC43 or -NC48 Configuration Cable
- PHOTOSWITCH 42SRU-6203
- 2755-IB5S DC Input Module
- Computer running Windows[™] 3.1 (or later) or Windows 95
- 9-to-25 Pin Adapter (for computers with a 25-pin COM port)

Software Requirements

The software requirements for this application is the 2755-ASN AdaptaScan Offline Programming Software.

Related Publications

Publications you may want to refer to include:

Publication	Description
2755-837	AdaptaScan Bar Code Readers User Manual
2755-838	AdaptaScan Software User Manual

Internal Power Source

The following illustration shows the wiring base connections. The 2755-IB5S DC input module and the 42SRU-6203 PHOTOSWITCH receive power from the Package Detect +12V internal power source in this application. You could also use an external AC or DC power source. Refer to the *AdaptaScan Bar Code Readers User Manual* (Publication No. 2755-837) for more information regarding using an external power source.

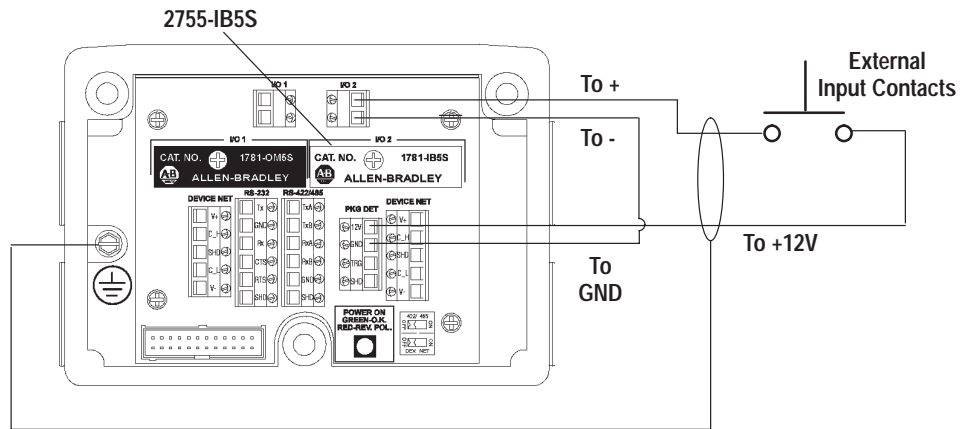

The circuit must not draw more than 50mA from the Package Detect terminal block.

Connecting a Power Supply to the Reader

The following illustration shows how to connect a 2755-PW46 or -PW47 power supply to a single bar code reader.

Use a shielded cable (Belden 9316 recommended) to make the connections. Connect the shield to the ground screw on the reader's wiring base.

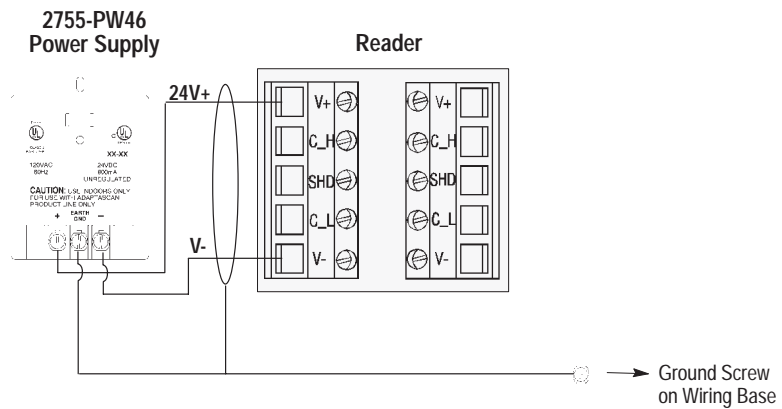

Configuring the Reader

This section shows how to configure the AdaptaScan Reader using the AdaptaScan software (Catalog No. 2755-ASN).

The procedures in this section show how to:

- configure a bar code label and symbol
- define a DeviceNet address
- configure the scanner
- configure the decoder trigger
- configure the discrete input module
- configure the match table, package and autoloader trigger source

Create a New Project

1. Select New from the Project menu to create a new project.
2. Click the New button to add a bar code reader (Bar Code Reader 1) to the project.

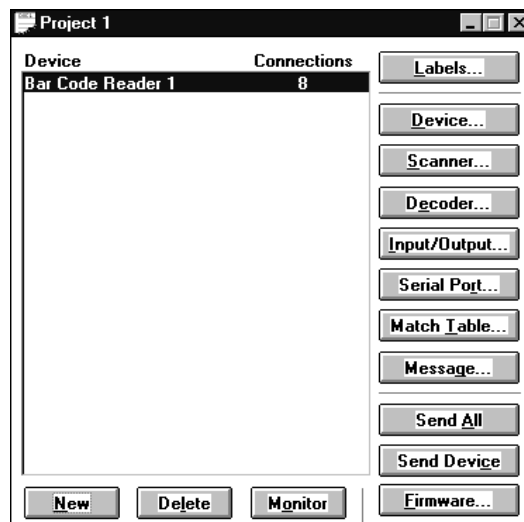

3. Choose Edit from the Project menu to rename the project **AutoLoad**.



4. Click Save to save the project under the new name and then click Close to return to the Project dialog.

Define a Bar Code Label

1. Click the Labels button to open the Bar Code Labels dialog.
2. Click the New button to add a label.

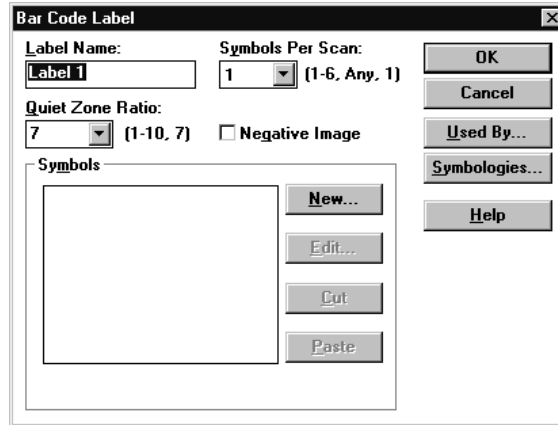

3. Click the New button to add a symbol.

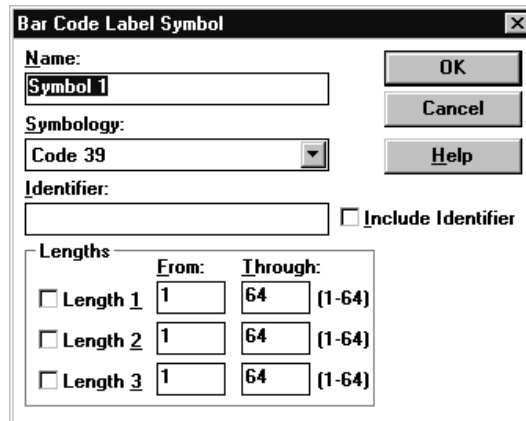

4. Select the symbology and define attributes such as Identifier and Lengths.
5. Click OK until you return to the Bar Code Labels dialog.
6. Click Save to save the new label setup.
7. Click Close to return to the main Project dialog.

Define the DeviceNet Address

1. Click the Device button on the Project dialog.

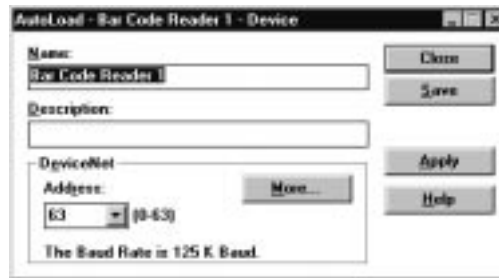

2. Select a DeviceNet address.
3. Connect the 2755-NC43 or -NC48 Configuration Cable to the reader.
4. Click the Apply button to send the DeviceNet address to the reader.
5. Click Save and Close to return to the main Project dialog.

Configure the Scanner

1. Click the Scanner button on the Project dialog to open the Scanner dialog.

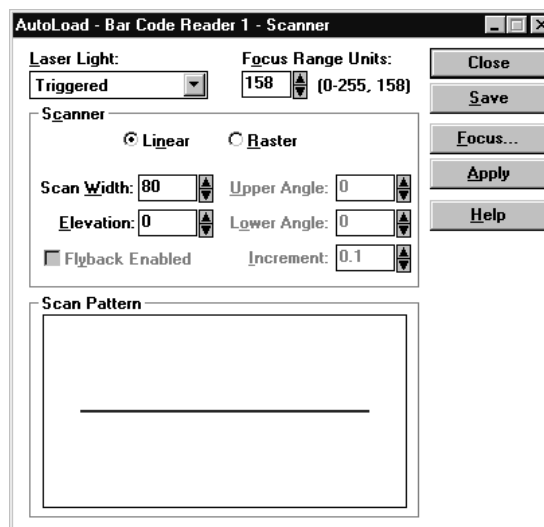

2. Configure the scan pattern and use the Focus procedure for optimum scanner focus.
3. Click the Close button to return to the main Project dialog.

Configure the Decoder

1. Click the Decoder button from the main Project dialog.
2. Under Triggered By, select **Package Detect** from the Input list.

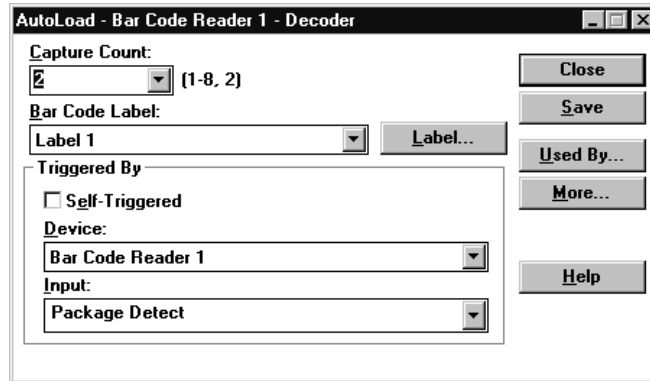

3. Click the Save button.
4. Click the Close button and return to the main Project dialog.

Configure the Discrete Input Module

The application uses a discrete input module to trigger the Auto-Load function. The following procedure defines one of the two input/output modules available in the AdaptaScan Bar Code Reader as an input.

1. Click the Input/Output button on the main Project dialog.
2. Under Inputs & Outputs, select **Discrete Input/Output 2**. This is the location of the 2755-IB5S DC Input Module in the reader's wiring base.
3. Under Use As, select **Input**.

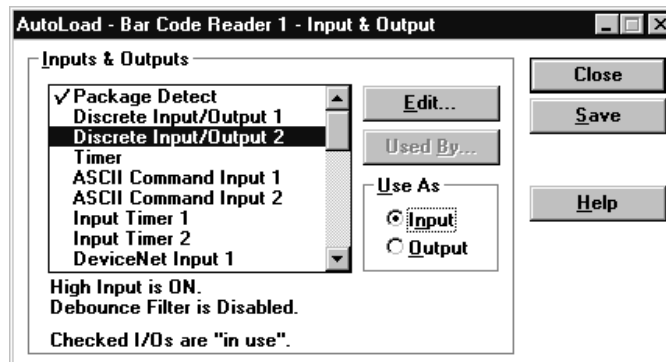

4. Click the Save button.
5. Click the Close button to return to the main Project dialog.

Configure the Match Table

The following procedure defines the contents of the match table and the source of the symbol to be matched.

1. Click the Match Table button on the main Project dialog.



2. Click the New button to open the Match Function dialog.
3. Select the following parameters for the Match Function:
 - Under Function, select **Auto-Load**
 - Under Symbol Source, select **Bar Code Reader 1**
 - Under Bar Code Labels & Symbols, select **Symbol 1** under Label 1
 - Check (enable) the Match Exactly check box

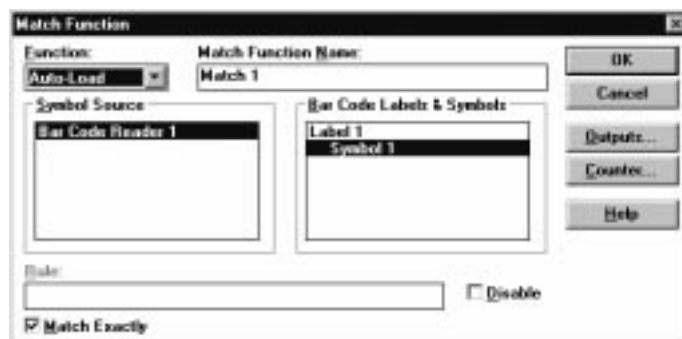

4. Click the OK button to return to the Match Table dialog.

Configure a Package

When the application is running, the I/O 1 LED energizes (no output module is actually installed in wiring base) when a No-Match or No-Read occurs. The following procedure defines this package function.

1. From the Match Table dialog, click the Package button to open the Packages dialog.

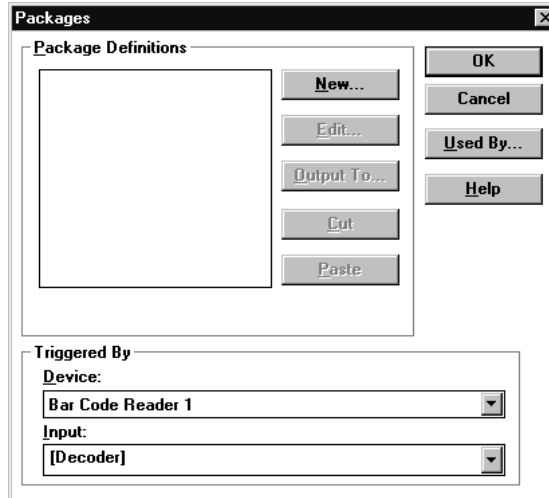

2. Click the New button to create a package.
3. Under Mode, select **No-Read or No-Match**.
4. Select **Match 1** under Match Functions.

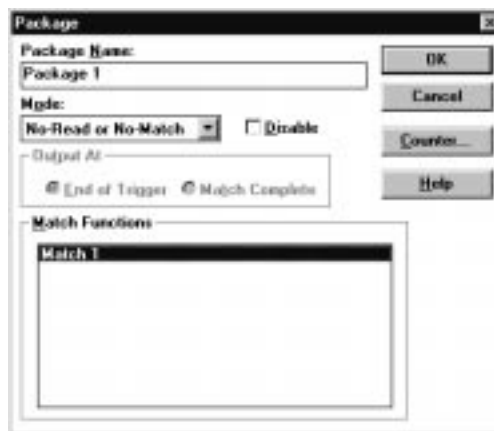

5. Click OK to return to the Packages dialog.

6. Click the Output To button to open the Package Outputs dialog.
7. Under Available Outputs, select **Discrete Input/Output 1**.
8. Click the Add>> button to add this selection under Output To:

Note: Discrete Input/Output 2 does not appear as an Available Output because it was previously defined as an input.

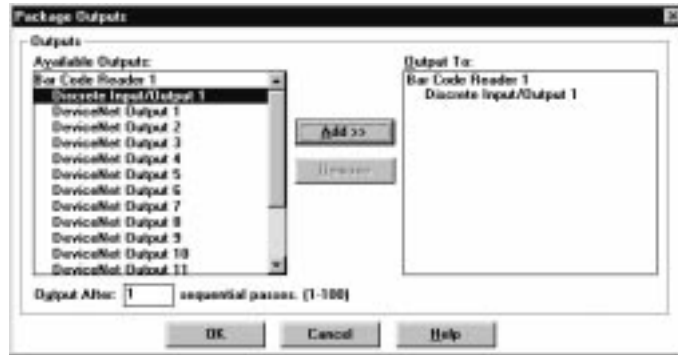

9. Click OK until you return to the Match Table dialog.

Configure the Auto-Load Trigger Source

The application uses a discrete input module (Discrete Input/Output 2) to activate the Auto-Load function. The following procedure shows how to configure the input which will activate Auto-Load.

1. Click the AutoLoad button from the Match Table dialog.
2. Under Auto-Load Trigger:
 - check the Enable check box.
 - select **Bar Code Reader 1** from the Device list.
 - select **Discrete Input/Output 2** from the Input list.

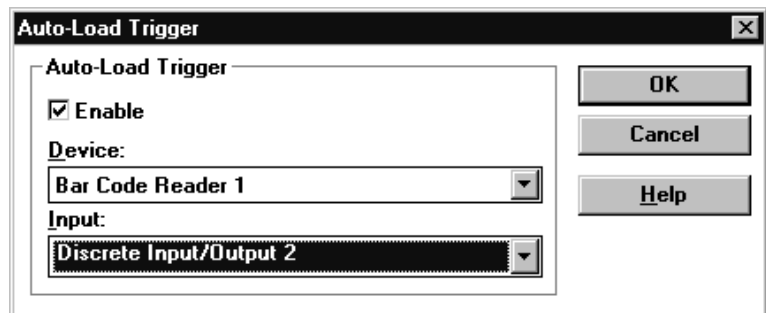

3. Click OK to return to the Match Table dialog.
4. Click Save and then Close to return to the Project dialog.

Sending the Configuration to the Reader

From the main Project dialog, click the Send Device button to download the configuration to the bar code reader.

Use the Monitor dialog to verify bar code labels as they are decoded.

Running the Application

When the application is running, bar code data is autoloaded by triggering the decoder (with Package Detect) when the desired symbol is scanned and decoded. If the bar code data is unreadable or does not match the autoloaded match string, I/O LED 1 turns on.

The following illustration shows the auto-load sequence using a Package Detect as a decoder trigger.

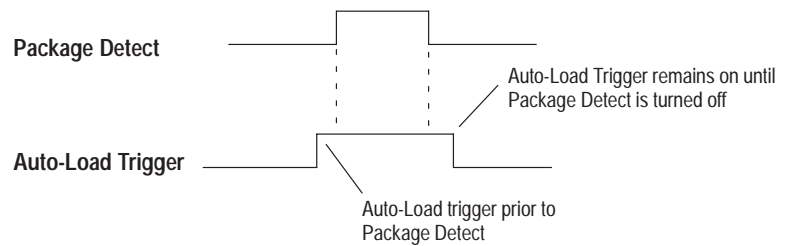

For more information on using Auto-Load, refer to chapter 10 in the *AdaptaScan Software User Manual* (Publication No. 2755-838).

Using ASCII Command Input

Overview

This application describes how to configure an AdaptaScan Bar Code Reader to receive ASCII commands from a terminal emulator over an RS-232 link:

- Terminal Emulator in Windows 3.1
- HyperTerminal in Windows 95

One character ASCII commands trigger the reader to start/stop scanning. For each trigger command the reader receives, it echoes a bar code string on the emulator.

The application includes the necessary cable diagrams and configuration information for the AdaptaScan Bar Code Reader.

Hardware Requirements

The hardware items required for this application are:

- 2755-SN3, -SN5 or -SN8 AdaptaScan Bar Code Reader
- 2755-NB40 or -NB41 Wiring Base
- 2755-NC43 or -NC48 Configuration Cable
- 2755-PW46 or -PW47 Power Supply
- Computer running Windows 3.1 (or later) or Windows 95
- 9-to-25 Pin Adapter (for computers with a 25-pin COM port)

Software Requirements

The software requirements for this application are:

- 2755-ASN AdaptaScan Offline Programming Software
- Terminal Emulator in Windows 3.1 or HyperTerminal in Windows 95

Related Publications

Publications you may want to refer to include:

Publication	Description
2755-837	AdaptaScan Bar Code Readers User Manual
2755-838	AdaptaScan Software User Manual

Connecting a Computer to the Reader

The following illustration shows the wiring base connections between the AdaptaScan Bar Code Reader and the personal computer. This RS-232 serial connection is used to download ASCII commands to the reader and to display bar code messages on the terminal emulator.

Create a cable using Belden 8303 (or equivalent) and a connector (to match your computer's RS-232 port). The other end of the cable is wired to the RS-232 port in the reader wiring base.

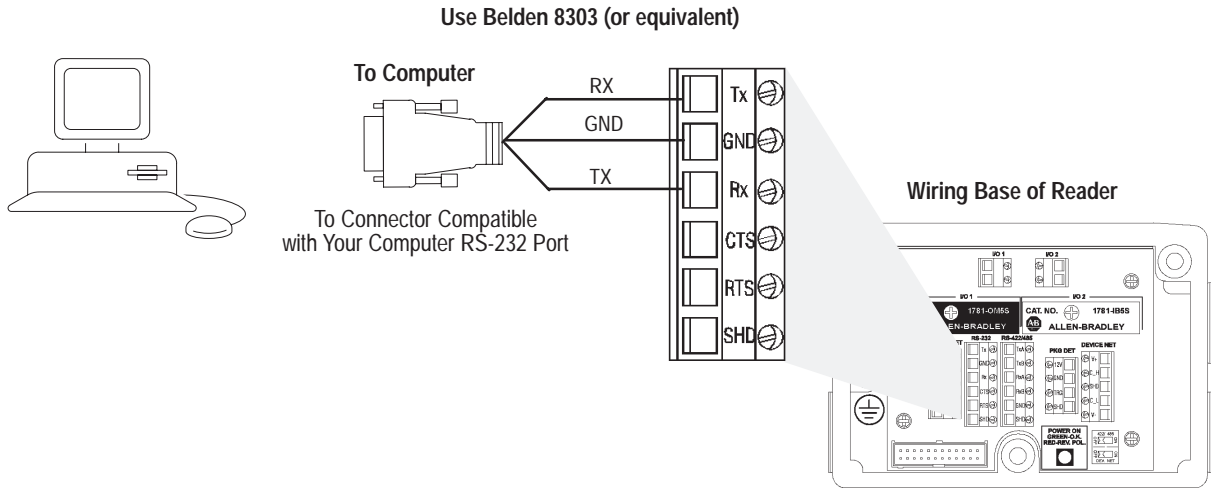

Connecting a Power Supply to the Reader

The following illustration shows how to connect a 2755-PW46 or -PW47 power supply to a single bar code reader.

Use a shielded cable (Belden 9316 recommended) to make the connections. Connect the shield to the ground screw on the reader's wiring base.

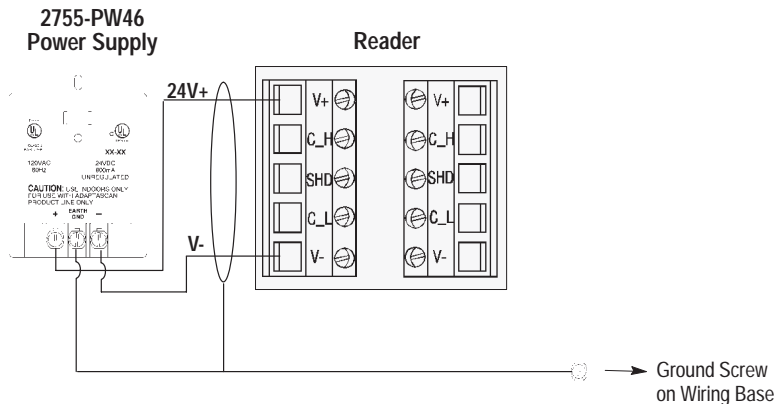

Configuring the Reader

This section shows how to configure the AdaptaScan Reader using the AdaptaScan Software (Catalog No. 2755-ASN).

The procedures in this section show how to:

- configure a bar code label and symbol
- define a DeviceNet address
- configure the scanner
- configure the decoder trigger for ASCII Command Input
- configure one character ASCII commands to start/stop scanning
- configure the serial port for terminal emulation
- define the format and content of messages

Create a New Project

Create a new project named ASCII Command Input for one AdaptaScan Bar Code Reader (Bar Code Reader 1).

1. Choose New from the Project menu to create a new project.
2. Click the New button to add a bar code reader (Bar Code Reader 1) to the project.

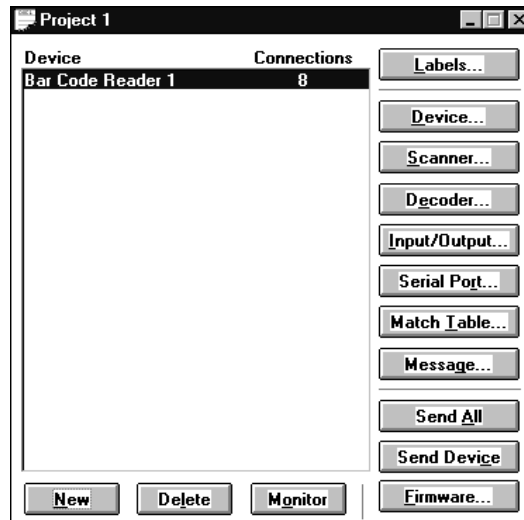

3. Choose Edit from the Project menu to rename the project **ASCII Command Input**.

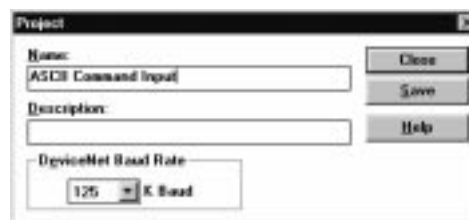

4. Click Save to save the project under the new name and then Close to return to the Project dialog.

Define the Bar Code Label

1. Click the Labels button to open the Bar Code Labels dialog.
2. Click the New button to define a label.

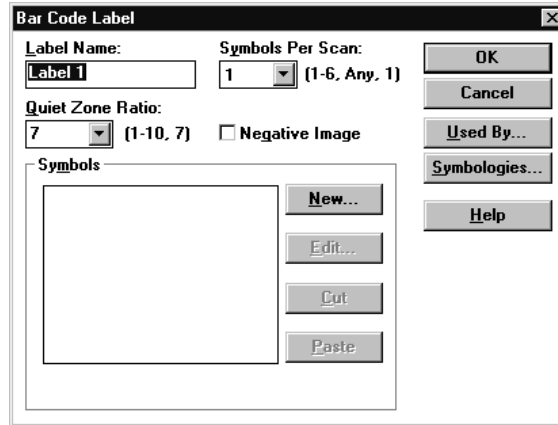

3. Click the New button to define a symbol for the label.

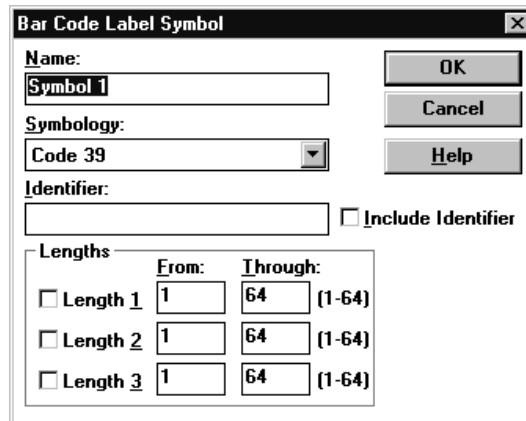

4. Select the symbology and define attributes such as Identifier and Lengths.
5. Click OK until you return to the Bar Code Labels dialog.
6. Click Save and then Close to return to the main Project dialog.

Define the DeviceNet Address

1. Click the Device button on the Project dialog.



2. Select a DeviceNet address.
3. Connect the 2755-NC43 or -NC48 Configuration Cable to the reader.
4. Click the Apply button.
5. Click Save and Close to return to the Project dialog.

Configure the Scanner

1. Click the Scanner button on the Project dialog to open the Scanner dialog.

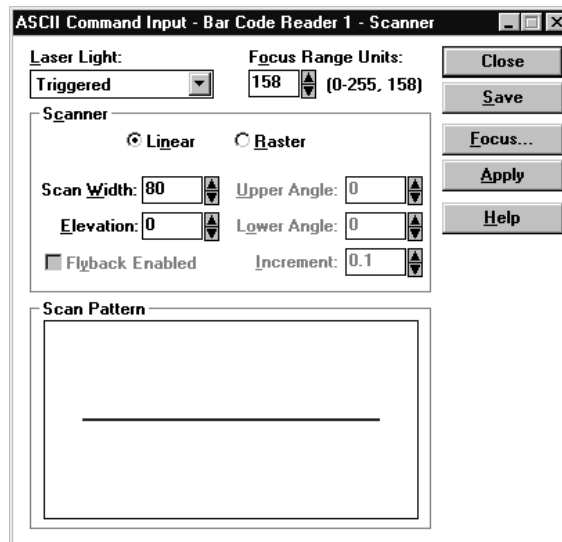

2. Configure the scan pattern and use the Focus procedure for optimum scanner focus.
3. Click the Close button and return to the Project dialog.

Configure the Decoder Trigger

This section defines ASCII Command Input 1 as the trigger for the reader's decoder.

1. Click the Decoder button from the main Project dialog.
2. Under Triggered By, select **ASCII Command Input 1** from the Input list.

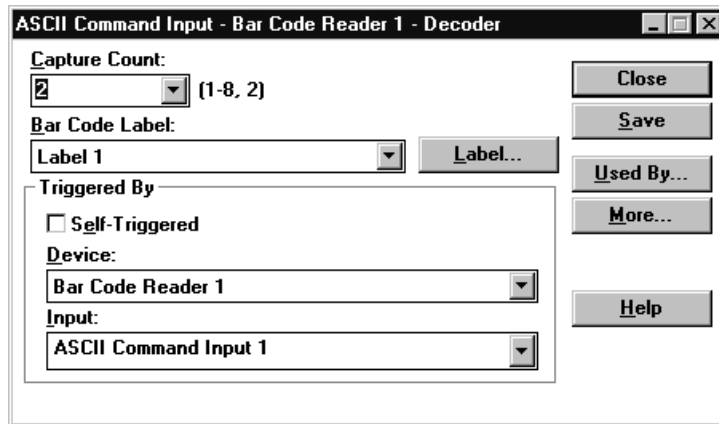

3. Click the Save button.
4. Click the Close button and return to the main Project dialog.

Configure the ASCII Commands

The following procedure defines the ASCII commands that will trigger the decoder to start/stop scanning.

1. Click the Input/Output button on the main Project dialog.
2. Under Inputs & Outputs, select **ASCII Command Input 1**.

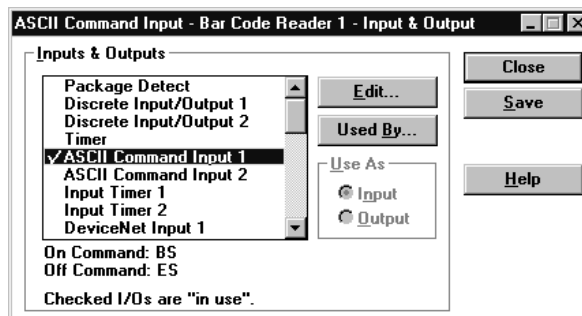

3. Click the Edit button to open the ASCII Command Input dialog.

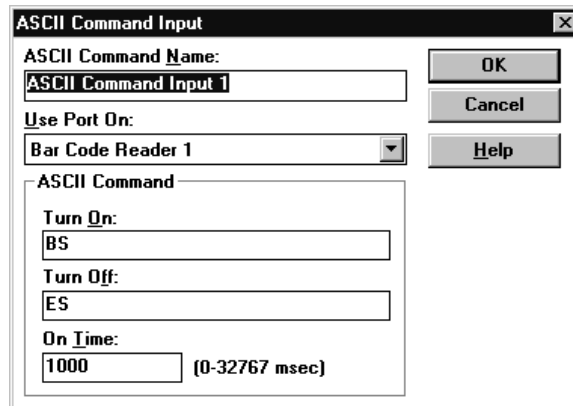

The screenshot shows a dialog box titled "ASCII Command Input". It has a close button (X) in the top right corner. The dialog contains the following fields and controls:

- ASCII Command Name:** A text box containing "ASCII Command Input 1".
- Use Port On:** A dropdown menu currently showing "Bar Code Reader 1".
- ASCII Command:** A section containing three sub-fields:
 - Turn On:** A text box containing "BS".
 - Turn Off:** A text box containing "ES".
 - On Time:** A text box containing "1000" with a range indicator "(0-32767 msec)" to its right.
- Buttons:** Three buttons are located on the right side: "OK", "Cancel", and "Help".

The default ASCII commands for triggering the decoder are two character commands:

- BS (Begin Scan)
- ES (End Scan)

This application uses one character ASCII commands to trigger the decoder.

- B (Begin Scan)
- E (End Scan)

4. In the Turn On field, type the letter **B**. (The command is case sensitive.)
5. In the Turn Off field, type the letter **E**. If you do not use an E in the Turn Off field, the trigger will then turn off in 1000 ms. (The command is case sensitive.)
6. Click the OK button.
7. Click the Save button to save the ASCII command definitions.
8. Click the Close button and return to the main Project dialog.

Configure the Serial Port

This section configures the RS-232 serial port so that it is compatible with the Terminal Emulator in Windows 3.1 or HyperTerminal in Windows 95.

1. Click the Serial Port button on the main Project dialog.

The screenshot shows a dialog box titled "ASCII Command Input - Bar Code Reader 1 - Serial Port". It contains several configuration options:

- Protocol:** A dropdown menu with "Terminal" selected. Below it is an "Edit..." button and a checkbox for "Scanner Protocol".
- Baud Rate:** A dropdown menu set to "9,600".
- Maximum Length:** A text input field containing "1" with "(0-1536, 0)" in parentheses next to it. To the right is a "Used By..." button.
- Parity:** Radio buttons for "None" (selected), "Odd", and "Even".
- Data Bits:** Radio buttons for "7" and "8" (selected).
- Stop Bits:** Radio buttons for "1" (selected) and "2".
- Connection:** A dropdown menu set to "RS232".
- Message Buffer:** A section with a checkbox for "Enable Warning", a "Warning At:" field set to "56", and a "Buffer Size:" field set to "64". Below these are "Device:" and "Output:" dropdown menus.
- Enable Pass-Through to DeviceNet:** A checkbox at the bottom of the dialog.

Buttons for "Close", "Save", "Help", and "Used By..." are also visible.

2. Verify that **Terminal** is selected in the Protocol list box.
3. In the **Maximum Length** field, type **1**.

With the Maximum Length set to 1, only one character is downloaded to the reader through the terminal via RS-232 port. If a message is configured, all bar code strings are read and uploaded to the terminal via RS-232 port.

If the Maximum Length is set to 2, only two characters are downloaded to the reader through the terminal via RS-232 port. However, if a message is configured, only 2 bar code data characters are uploaded to the terminal. The same is true for a setting ≥ 3 .

4. Select **RS232** from the Connection list box.

5. Click the Edit button under Protocol.
6. Under Flow Control, select **None**.

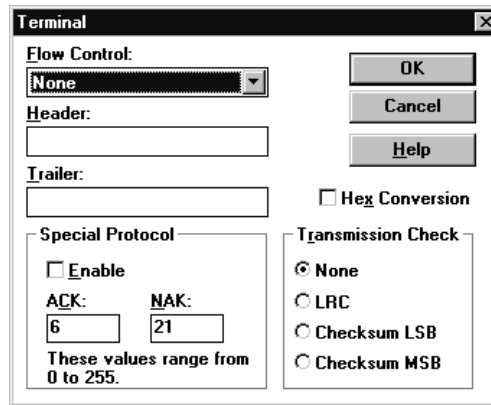

7. Click OK to close the dialog.
8. Click the Save button to save the serial configuration.
9. Click Close to return to the main Project dialog.

Create a Message

This section defines the content of the message sent from the reader to the terminal emulator.

1. Click the Message button from the main Project dialog.



2. Under Triggered By, check the Enable check box.
3. Under Device, select **Bar Code Reader 1**.
4. Under Input, select **[Decoder]**.
5. Click the New button to define a message field.



6. Under Symbol Source, select **Bar Code Reader 1**.
7. Under Bar Code Labels & Symbols, select **Symbol 1**.
8. Check (enable) the Match Exactly check box.
9. Click the Edit button to open the Message Field Edit dialog.

- Under Replacement Strings, type **nr** in the Fail: field.

Bar code data is sent to the emulator on a valid read. The Fail string sends the characters “nr” when a no read occurs.

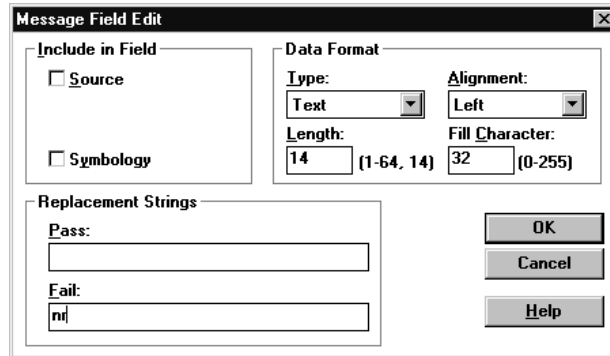

- Click OK to return to the Message Field dialog.
- Click OK to return to the Message dialog.

Define the Message Format

This section defines the format of the message to display on the terminal emulator.

- Click the Format button from the Message dialog.



- In the Trailer field, type **\r\n** (Carriage Return, Line Feed).
- Under Message Destination, select **Serial Port**.
- Click OK to return to the Message dialog.
- Click the Save button and then the Close button to return to the Project dialog.

Sending the Configuration to the Reader

From the main Project dialog, click the Send Device button to download the configuration to the bar code reader.

Running the Application

If your computer does not have two serial ports, switch the 2755-NC43 or -NC48 cable to the serial cable already wired to the AdaptaScan Reader's wiring base.

In the following illustration:

- ASCII command B is entered to trigger the decoder to start scanning.
- ASCII command E is entered to stop scanning. A timeout occurs if an E is not entered.
- Bar code data is displayed on the terminal emulator.

You must type B to trigger the decoder again and display the next bar code string on the emulator.

Terminal Emulator Example

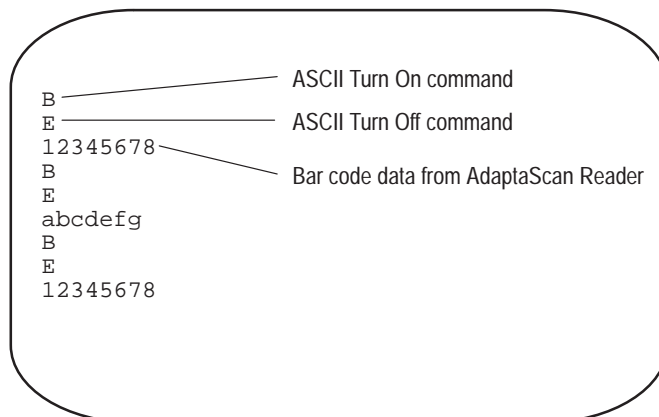

Downloading Match Codes from a Host Device

Overview

This application describes how to download match codes to the bar code reader from a terminal emulator using an RS-232 connection. It also describes how to download other host commands using the same procedures.

Hardware Requirements

The hardware items required for this application are:

- 2755-SN3, -SN5, -SN8 AdaptaScan Bar Code Reader
- 2755-NB40 or -NB41 Wiring Base
- 2755-PW46 or -PW47 Power Supply
- 2755-NC43 or -NC48 Configuration Cable
- Communication Cable with Connector for PC (Belden 8303 or equivalent)
- Computer running Windows 3.1 (or later) or Windows 95
- 9-to-25 Pin Adapter (for Computer with 25-pin COM port)

Software Requirements

The software requirements for this application are:

- 2755-ASN AdaptaScan Offline Programming Software
- Terminal Emulator in Windows 3.1 or HyperTerminal in Windows 95

Related Publications

Related publications include:

Publication	Description
2755-837	AdaptaScan Bar Code Readers User Manual
2755-838	AdaptaScan Software User Manual

Connecting a Computer to the Reader

The following illustration shows the wiring base connections between the AdaptaScan Bar Code Reader and the personal computer. This RS-232 serial connection is used to download match codes to the reader from a terminal emulator. Do not connect the cable to the computer until after the application is downloaded to the reader (see page 3-10).

Create a cable using Belden 8303 (or equivalent) and a connector (to match your computer's RS-232 port). The other end of the cable is wired to the RS-232 port in the reader wiring base.

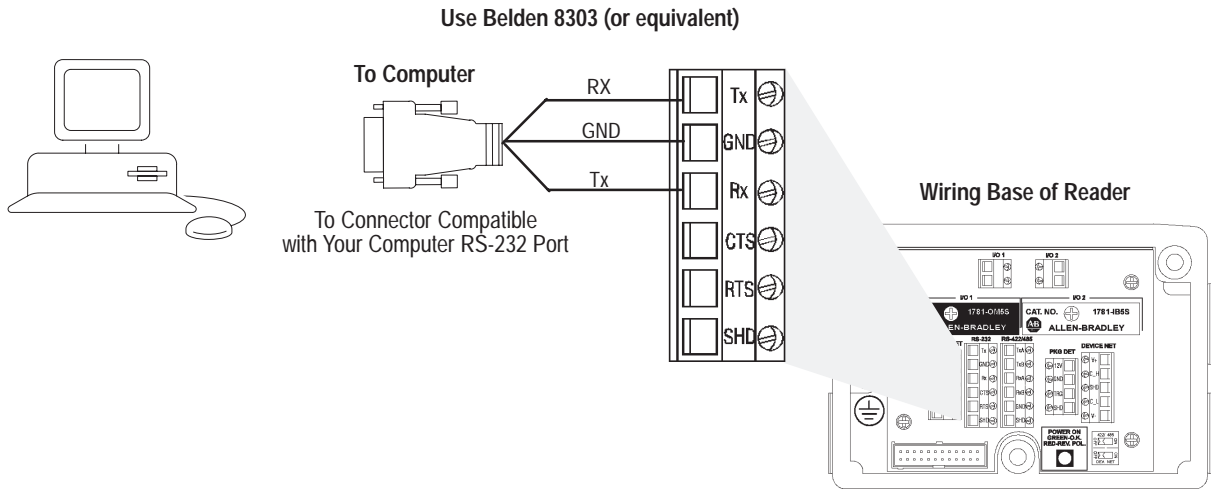

Connecting a Power Supply to the Reader

The following illustration shows how to connect a 2755-PW46 or -PW47 power supply to a single bar code reader.

Use a shielded cable (Belden 9316 recommended) to make the connections. Connect the shield to the ground screw on the reader's wiring base.

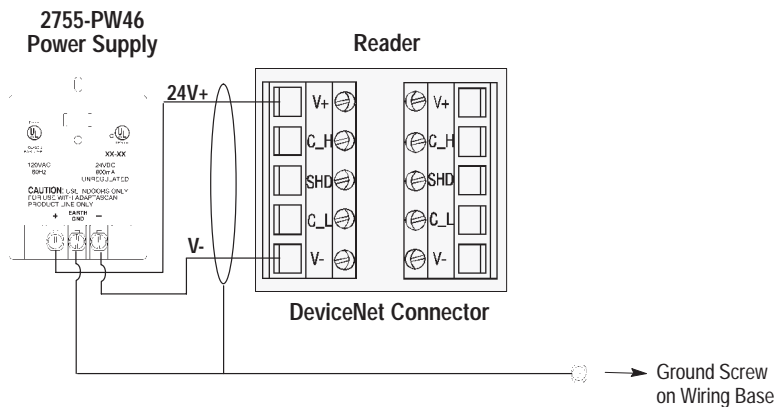

Verify the connection by applying power to the wiring base and observing the polarity LED. The LED should be green. If the LED is red, the polarity needs to be reversed. Disconnect power from wiring base until the reader is installed.

Configuring the Reader

This section shows how to configure one the AdaptaScan Bar Code Readers using the AdaptaScan Software (Catalog No. 2755-ASN).

The procedures in this section show how to:

- define the DeviceNet node address of the AdaptaScan Reader
- configure a bar code label and symbol
- configure the scanner
- configure the decoder trigger
- configure the serial port
- configure the format of messages and the message destination

The steps may vary for some procedures because of the different requirements of applications. For example, the bar code labels may vary from one application to the next.

Create a New Project

This section adds a bar code reader to a new project and then renames the project Download Match Codes.

1. Choose New from the Project menu to create a new project.
2. Click the New button to add a bar code reader (Bar Code Reader 1) to the project.



3. Choose Edit from the Project menu to rename the project **Download Match Codes**.

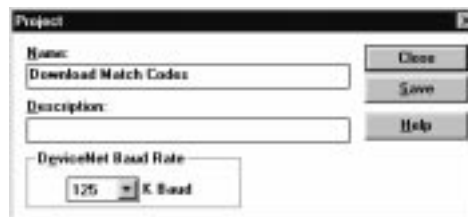

4. Click Save to save the project under the new name and then Close to return to the Project dialog.

Define the Bar Code Label

This section configures the reader to scan/decode Interleaved 2 of 5 symbols.

1. Click the Labels button to open the Bar Code Labels dialog.
2. Click the New button to define a label.

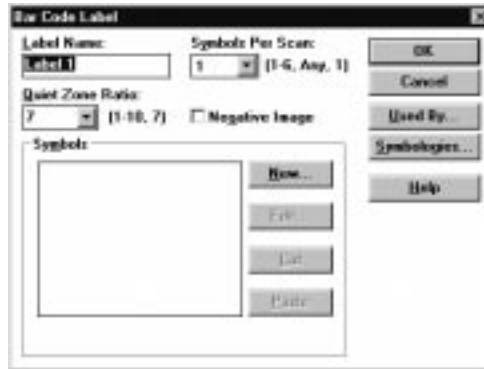

3. Click the New button to define Symbol 1.

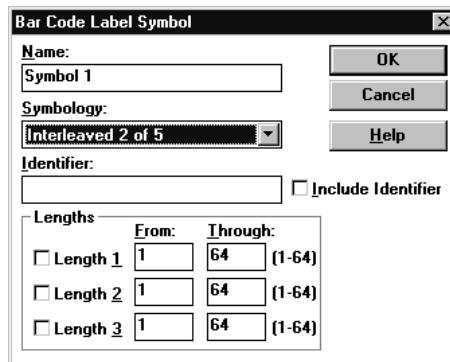

4. From the Symbology list box, select **I 2 of 5**.

To edit parameters of the selected symbology, click the Symbologies button.

5. Click OK until you return to the Bar Code Labels dialog.
6. Click Save and then Close to return to the main Project dialog.

Define the DeviceNet Address

1. Click the Device button on the Project dialog.



2. Select a DeviceNet address.
3. Connect the 2755-NC43 or -NC48 Configuration Cable to the Reader.
4. Click the Apply button.
5. Click the Close button and return to the Project dialog.

Configure the Scanner

1. Click the Scanner button on the Project dialog to open the Scanner dialog.



2. Configure the scan pattern and use the Focus procedure for optimum scanner focus.
3. Click the Close button and return to the Project dialog.

Configure the Decoder Trigger

Bar Code Reader 1 is triggered by a Timer. The Timer is typically used during initial setup to simulate a package detector.

The Timer is set for a specified On Time (1 second) and Off Time (1 second).

1. Click the Decoder button from the main Project dialog.



2. Under Triggered By, select **Timer** from the Input list.
3. Click the Save button and the Close to return to the main Project dialog.

Configure the Serial Port

Configure the parameters of the serial port to match the host device.

1. Click the Serial Port button from the main Project dialog.



2. Under Protocol, select:
 - select **Terminal**
 - check (enable) the Scanner Protocol check box

Scanner Protocol is used when a host (e.g., PLC or computer) is connected to a serial port in the reader's wiring base.

3. From the Connection list box, select **RS232**.
4. Click the Edit button to configure the parameters for Terminal protocol.



5. In the Trailer text box, type `\r\n` (inserts carriage return and line feed).
6. Check (enable) the Hex Conversion check box.
7. Click OK to return to the Serial Port dialog.
8. Click Save and then the Close button to return to the Project dialog.

Configuring a Match Entry and I/O Indicator LED

The application turns on output 1 when a symbol is read. This provides a convenient method of determining whether or not the reader is decoding a label. The discrete output is turned on by the match table.

1. Click the Match Table button on the main Project dialog.



2. Click the New button to open the Match Function dialog.

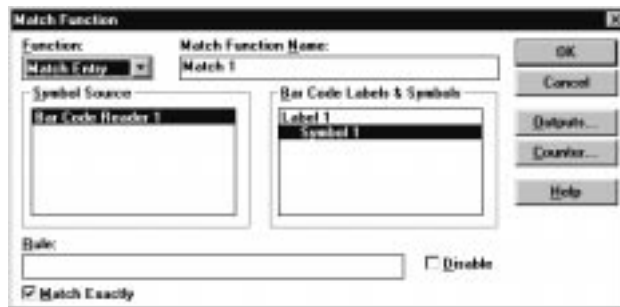

3. Under Function, select **Match Entry** from the list box.

Match Entry specifies that a match occurs whenever decoded bar code data matches the Rule: entry.

4. Under Symbol Source, select **Bar Code Reader 1**.
5. Under Bar Code Labels & Symbols, select **Symbol 1**.
6. Check (enable) the Match Exactly check box.

Match Exactly specifies that ASCII characters are matched instead of a metacharacter rule (metacharacters are not used in this example).

7. Click the Outputs button to specify which output activates when a match occurs.

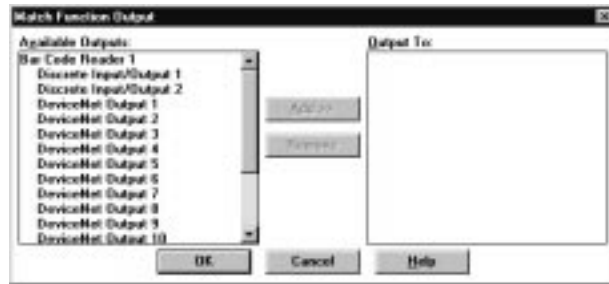

8. Under Available Outputs, select **Discrete Input/Output 1**.

9. Click the Add>> button to add this selection to the Output To: area.

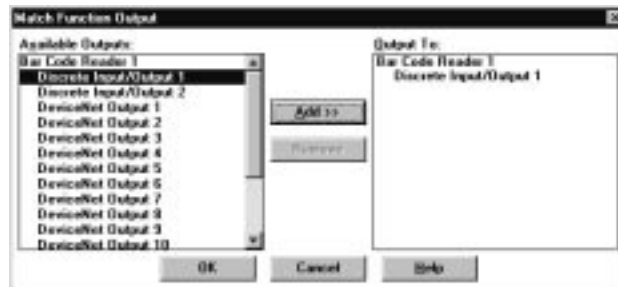

10. Click OK until you return to the Match Table dialog.

11. Click Save and then Close to return to the Project dialog.

Sending the Configuration to the Reader

From the main Project dialog, click the Send Device button to download the configuration to the bar code reader.

Finding Match Table Instances

When you download match codes from a host, you need the instance number of the match table. Do not assume that Match 1 = Instance 1, Match 2 = Instance 2.

From the Project menu, select Print. The printout will show the class and instance numbers.

Name	Class	Address/Instance
Bar Code Reader 1		63
Match 1	206	1
Match 3	206	3
Match 4	206	4
Match 2	206	5
Match 5	206	6
Field 1	204	1

Connecting the Computer to the RS-232 Port

Disconnect the 2755-NC43 or -NC48 Configuration Cable from the personal computer. Connect the communication cable previously connected to the RS-232 connector in the wiring base to the computer's RS-232 serial COM port.

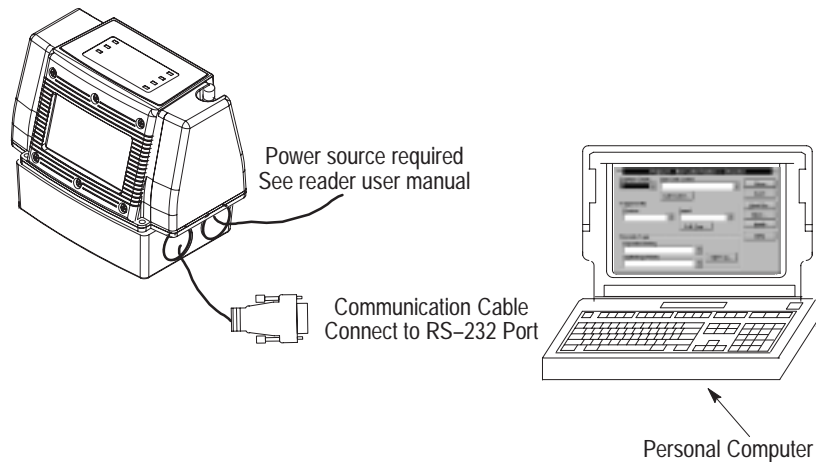

Downloading Match Codes

To download match codes from your computer you must:

1. Convert the match string to hex.
2. Enter the match string in the proper data packet format.
3. Send the data packet (containing the string) to the reader.

Convert the Bar Code String to Hex

Convert the bar code string you want to send to the reader to the hexadecimal ASCII equivalent value. For example:

Bar Code String:

0	2	0	0
---	---	---	---

Converted Hex Value:

30	32	30	30
----	----	----	----

Converted Bar Code Length Value:

0	4	0	0
---	---	---	---

In the bar code length shown above, if the number of characters 04 were changed to 14, the hexadecimal value would be 0E. This hexadecimal value is written as 0E00.

Place the String in the Data Packet

The bar code string is sent in a data packet having this format:

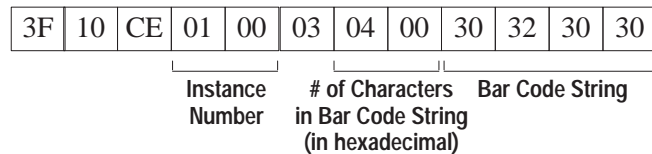

The following are descriptions of the data packet:

- 3F = DeviceNet Address (3F= 63, each reader has unique address)
- 10 = Set attribute (single request)
- CE = 206 = Class (always 206 for match table)
- 01 = Instance Number (LSB)
- 00 = Instance Number (MSB)
- 03 = Attribute Number – Rule
- 04 = Length of String (LSB)
- 00 = Length of String (MSB)
- 30 = ASCII “0”
- 32 = ASCII “2”
- 30 = ASCII “0”
- 30 = ASCII “0”

Note: You can use the Windows calculator to convert decimal values to hexadecimal.

Send Data to the Reader

1. Use the Windows terminal function to send the data. Locate the terminal icon (usually within the Accessories group icon).

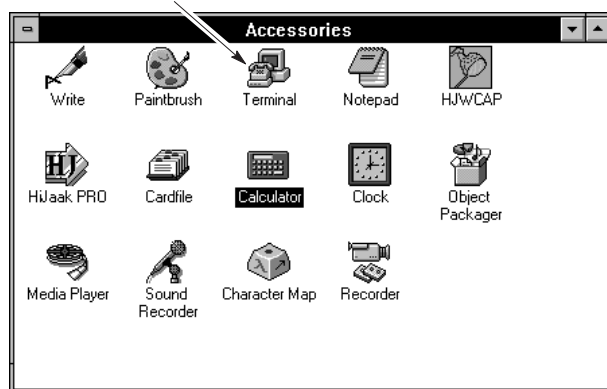

2. Open the terminal icon.



3. From the Settings menu open the Communications dialog and make sure that the settings match the reader serial port settings.

Note: 9600 Baud must be selected.

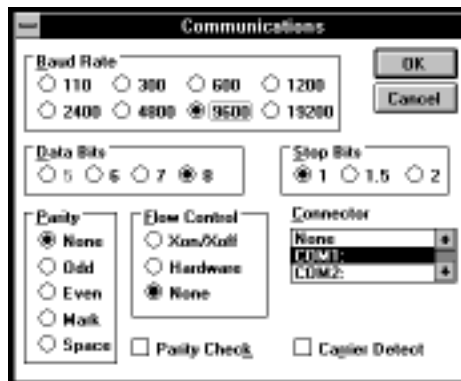

- From the Settings menu open the Terminal Preferences dialog and select Local Echo and Outbound (CR/LF).

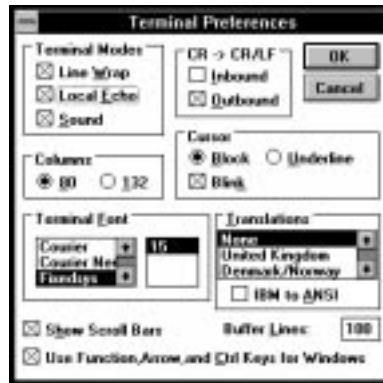

- Return to the terminal window and enter the data string to download. All characters must be in uppercase.



- Press Return to send the data.

The terminal window will display the response.



The response of 3F90 indicates a good write of the match code.



Note: Refer to the next page for a description of the response code format and codes.

You can verify whether or not a correct match code was downloaded by placing a bar code label in front of the reader so that it is scanned. Observe the Output #1 LED on the top of the reader. When the downloaded match code matches a scanned label, the output will turn on.

If you receive a response code other than 90, refer to the the response code chart on the next page.

Response Codes

Response codes have the following format:

Byte	Contents
0	Mac ID (Address)
1	94 = Error Response
2	x = General Error Code
3	x = Additional Code

General Error Codes

Code (hex)	Name
02	Resource unavailable
08	Service not supported
09	Invalid attribute value
0B	Already in requested mode/state
0C	Object cannot perform service in its current mode/state
0E	Attribute not settable
0F	Access permission does not allow service
10	Device's mode/state does not allow object to perform service
11	Reply data too large
13	Not enough data
14	Attribute not supported
15	Too much data
16	Object does not exist
18	No stored attribute data
19	Store operation failure
D0-FF	Class specific

Downloading Other Host Commands

You can download other host commands using the same procedures described in the match code example. The following tables provide the commands and responses for the other host commands (all values are hexadecimal).

Read Performance Indicator Command

Packet Contents	Data Sent
DeviceNet Address	3F*
Get Performance Request	4C
Class	C8
Instance Number (LSB)	01
Instance Number (MSB)	00

*3F = Address 63, modify as required

Read Performance Indicator Response

Packet Contents	Response
DeviceNet Address	3F
Get Performance Response	CC
Data (LSB)	01
Data (MSB)	00

Reset Package Counter Command

Packet Contents	Data Sent
DeviceNet Address	3F*
Set Attribute Request	10
Class	D2
Instance Number (LSB)	00
Instance Number (MSB)	00
Attribute Number- Reset Counters	09
Data	01

*3F = Address 63, modify as required

Reset Package Counter Response

Packet Contents	Response
DeviceNet Address	3F
Set Attribute Response	90

Read Match Counters Command

Packet Contents	Data Sent
DeviceNet Address	3F*
Get Attribute Request	0E
Class	CE
Instance Number (LSB)	01
Instance Number (MSB)	00
Attribute Number	08

*3F = Address 63, modify as required

Read Match Counters Response

Packet Contents	Response
DeviceNet Address	3F
Get Attribute Response	8E
Data	6C, 08, 00, 00

Read Package Counters Command

Packet Contents	Data Sent
DeviceNet Address	3F*
Get Attribute Request	0E
Class	D2
Instance Number (LSB)	01
Instance Number (MSB)	00
Attribute Number- Match Count	08

*3F = Address 63, modify as required

Read Package Counters Response

Packet Contents	Response
DeviceNet Address	3F
Get Attribute Response	8E
Data	6C, 08, 00, 00

Reset Match Counters Command

Packet Contents	Data Sent
Response Codes	3F*
Set Attribute Request	10
Class	CE
Instance Number (LSB)	00
Instance Number (MSB)	00
Attribute Number- Reset Counters	0B
Data	01

*3F = Address 63, modify as required

Read Message Command

Packet Contents	Data Sent
DeviceNet Address	3F*
Get Attribute Request	0E
Class	CC
Instance Number (LSB)	00
Instance Number (MSB)	00
Attribute Number - Message	14

*3F = Address 63, modify as required

Read LED Status Command

Packet Contents	Data Sent
DeviceNet Address	3F*
Read LEDS Request	43
Class	CB
Instance Number (LSB)	01
Instance Number (MSB)	00

*3F = Address 63, modify as required

Reset Match Counters Response

Packet Contents	Response
DeviceNet Address	3F
Set Attribute Response	90

Read Message Response

Packet Contents	Response
DeviceNet Address	3F
Get Attribute Response	8E
Data (LSB)	04
Data (MSB)	00
ASCII Message Data	30*
ASCII Message Data	32
ASCII Message Data	30
ASCII Message Data	30

* Example data = 0200

Read LED Status Response

Packet Contents	Response
3F	3F
Read LEDS Response	C3
I/O 1	See Table Next Page
I/O 2	See Table Next Page
Trigger / Read	See Table Next Page
On Symbol	See Table Next Page
Laser On	See Table Next Page
Module	See Table Next Page
Network	See Table Next Page

Set Output Timer Command

Packet Contents	Data Sent
DeviceNet Address	3F*
Set Attribute Request	10
Class	D0
Instance Number (LSB)	02
Instance Number (MSB)	00
Attribute Number - Max Time	09
Data (LSB)	FA
Data (MSB)	00

*3F = Address 63, modify as required

** Time in milliseconds

Set Output Timer Response

Packet Contents	Response
DeviceNet Address	3F
Set Attribute Response	90

LED Status Response

Byte	Bits	LED Indicator	Data at Indicated Bit Address = LED State							
			0 = Off	1 = Yellow	2 = Green	3 = Red	4 = Not Used	5 = Flash Yellow	6 = Flash Green	7 = Flash Red
0	0-2	I/O 1	OFF	ON						
	3-5	I/O 2	OFF	ON						
1	0-2	TRIGGER / READ	No Trigger	Triggered	Valid Read					
	3-5	ON SYMBOL	Not Reading	Reading				Read <100%		
2	0-2	LASER ON	OFF	ON						
	3-5	MODULE	No Power		Device OK	Hardware Fault			Power Up	Minor Fault
3	0-2	NETWORK			DeviceNet OK	DeviceNet Fault			Established	No Response
	3-5									

Downloading Match Codes via DH485 Protocol with an SLC 5/03™ or SLC 5/04™ Controller

Overview

This application describes how to download match codes to the bar code reader from an SLC 5/03 or SLC 5/04 controller using DH485 protocol in master and slave modes.

DH485 Master is used for bar code data traveling at medium or slow speeds. Data is sent to the SLC 5/03 or SLC 5/04 controller whether it was requested or not by the SLC 5/03 or SLC 5/04 controller.

DH485 Slave is used for bar code data traveling at high speeds. The SLC 5/03 or SLC 5/04 controller initiates the request for bar code data.

Refer to chapter 3 for a listing of additional host commands and response codes.

Hardware Requirements

The hardware items required for this application are:

- 2755-SN3, -SN5, or -SN8 AdaptaScan Bar Code Reader
- 2755-PW46 or -PW47 Power Supply
- 2755-NC43 or -NC48 Configuration Cable
- 2755-NB40 or -NB41 Wiring Base (Ser. A/Rev. B or higher)
- 1747-L532, -L541, -L542, or -L543 SLC Processor
- 1746-A4, -A7, -10, or -A13 Chassis
- 1746-P3 Power Supply
- 1747-CP3 RS-232 Programming Cable
- 1747-AIC Isolated Link Coupler or 1761-NET-AIC Advanced Interface Converter
- 1747-PIC RS-232/DH-485 Converter
- Computer running Windows 3.1 (or later) or Windows 95
- 9-to-25 Pin Adapter (for computers with a 25-pin COM port)

Software Requirements

The software requirements for this application are:

- 2755-ASN AdaptaScan Offline Programming Software
- 9323-PA2E Advanced Programming Software. (The original ICOM SLC software is not compatible with this AdaptaScan network.)

Related Publications

Related publications include:

Publication	Description
2755-837	AdaptaScan Bar Code Readers User Manual
2755-838	AdaptaScan Software User Manual
1747-6.2	SLC 500™ Modular Hardware Style Installation and Operation Manual
9399-APSUM-11.15.95	Advanced Programming Software User Manual

Connecting a Power Supply to the Reader

The following illustration shows how to connect a 2755-PW46 or -PW47 power supply to a single bar code reader.

Use a shielded cable (Belden 9316 recommended) to make the connections. Connect the shield to the ground screw on the reader's wiring base.

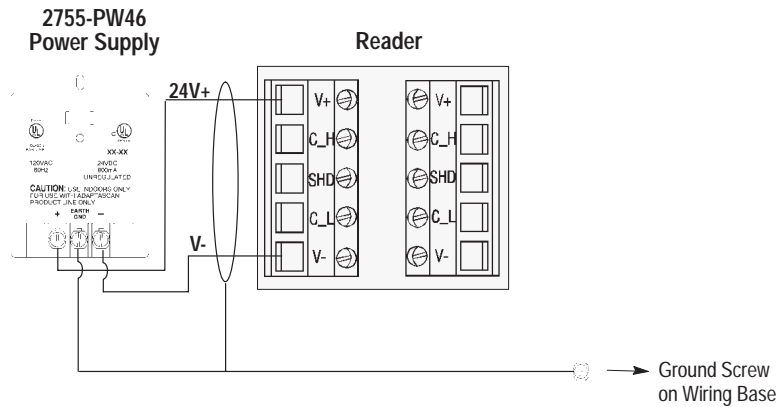

Connecting to the DH-485 Network

The wiring base of the AdaptaScan Reader has an RS-485/RS-422 terminal block for point-to-point or network connections.

This section shows three connection options:

- Connecting readers to SLC 5/03
- Connecting readers to SLC 5/04 using two 1747-AIC Modules
- Connecting readers to SLC 5/04 using one 1747-AIC Module

Note: You can use the 1761-NET-AIC Advanced Interface Converter in place of the 1747-AIC Module.

Important: The DH485 network cable requires proper shielding, grounding and termination. Refer to Data Highway/Data Highway Plus/Data Highway DH485 Cable Installation Manual (Publication 1770-6.2.2).

Important: When setting up a DH-485 network using an AdaptaScan, make sure that the nodes on the network are in sequential order. The SLC 5/03 or 5/04 should be Node 1, and AdaptaScan should be Node 2, and each node after that should be 3, 4, and so forth. If other DH-485 nodes are needed (i.e. DTAM, etc...), the AdaptaScan node number(s) must be first. Node gaps must be avoided in order to prevent the AdaptaScan from Soliciting of Successor (SOS). By preventing SOS, bar code throughput is maximized as it is sent to the SLC. In other words, when setting up the AdaptaScan via DH-485 the first priority is to process bar code data instead of finding node gaps.

Connecting Readers to SLC 5/03 Controller

You must use a link coupler if the distance between the reader and the SLC is greater than 15.2 meters (50 feet). The reader can connect directly to another RS-485/RS-422 device. Point-to-point and network connections are the same.

The end devices on the DH-485 network must be terminated. The wiring base of the AdaptaScan Reader provides a termination switch.

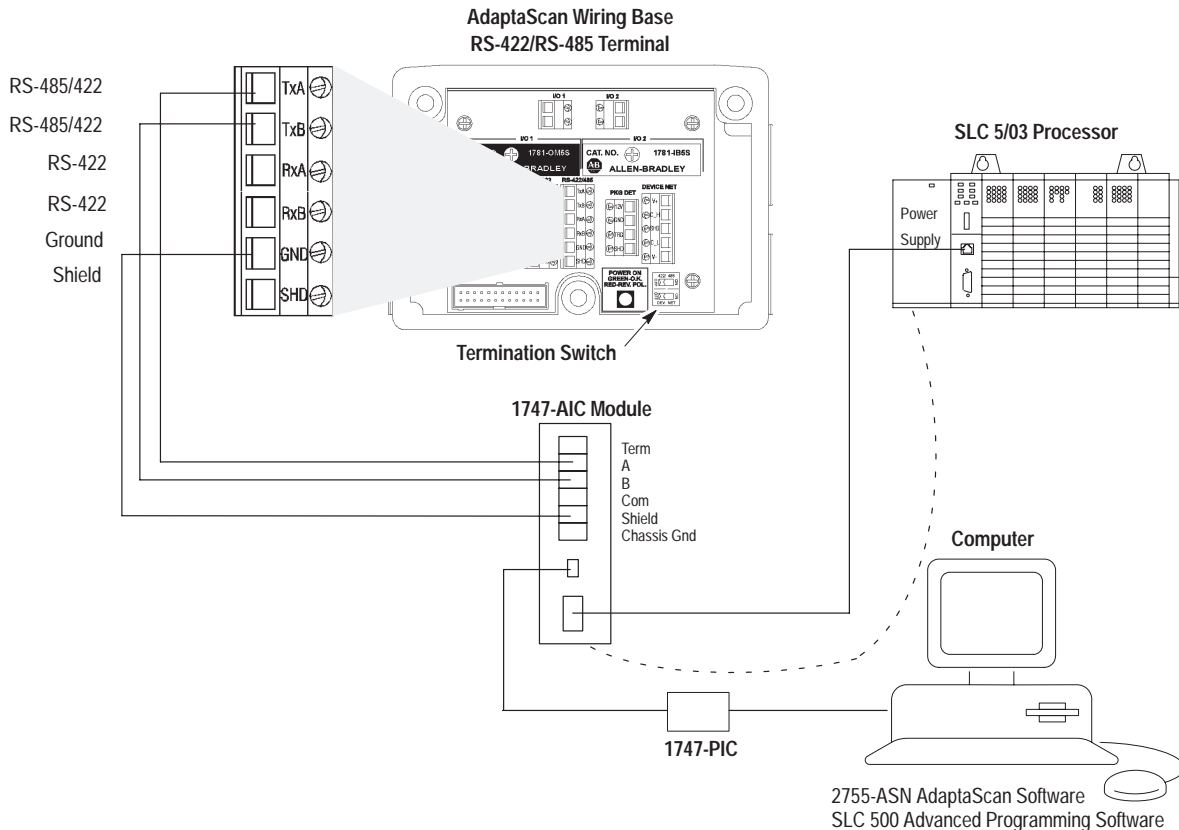

Connecting Readers to SLC 5/04 Controller – 2 AIC Modules

The SLC 5/04 controller requires two 1747-PIC converters and a power supply to connect to the second 1747-AIC module.

The end devices on a DH-485 network must be terminated. The wiring base of the AdaptaScan Reader provides a termination switch.

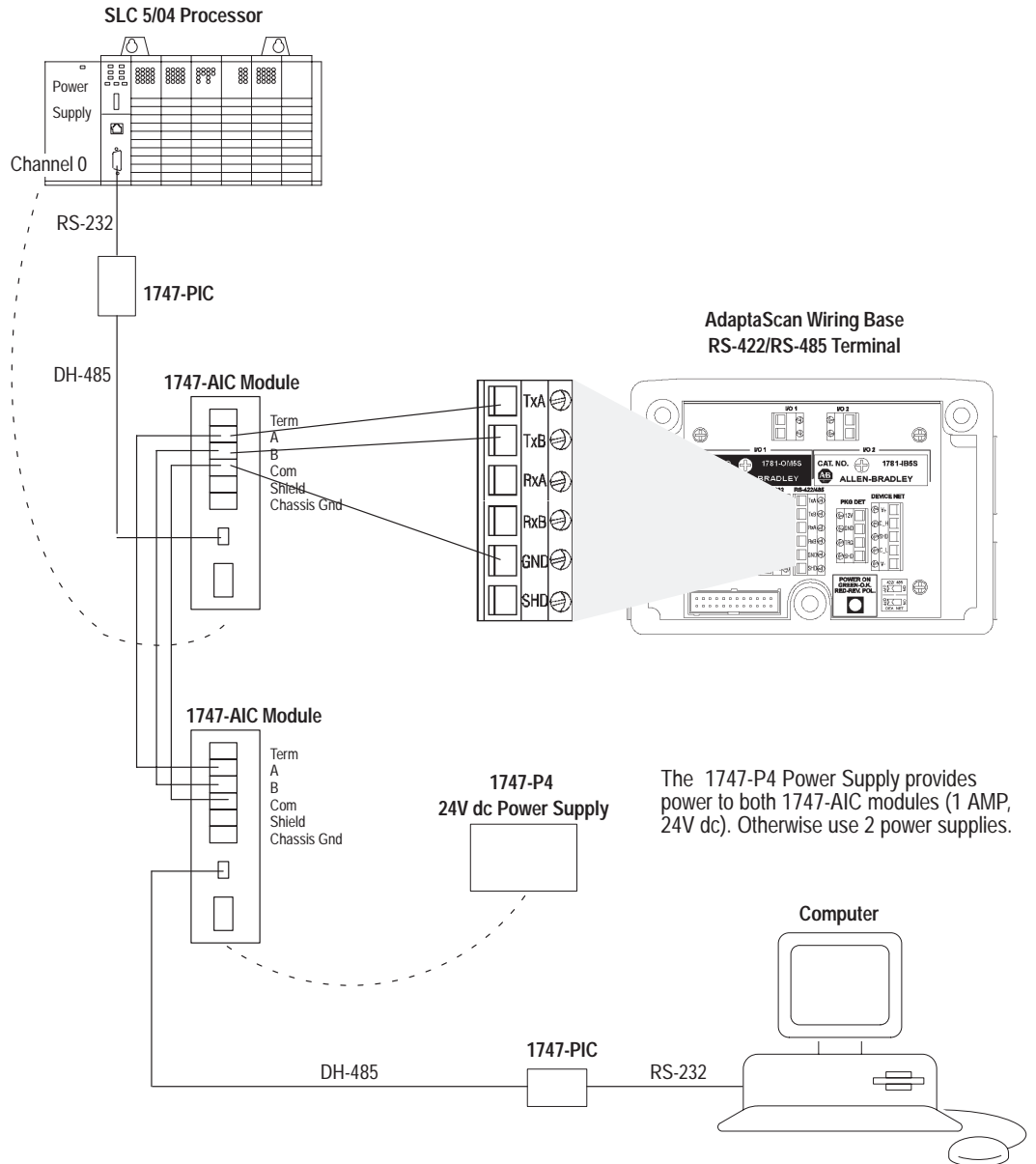

Connecting Readers to SLC 5/04 Controller – 1 AIC Module

The SLC 5/04 controller requires two 1747-PIC converters. However, you can use an RJ48 Y adapter (8-wire LAN phone jack plug) to connect the two 1747-PIC modules. The RJ48 Y adapter is a modular adapter for 4-pair cable which parallels two 4-pair jacks and one 4-pair modular plug. This adapter eliminates the second 1747-AIC module shown in the previous SLC 5/04 network diagram.

The end devices on a DH-485 network must be terminated. The wiring base of the AdaptaScan Reader provides a termination switch.

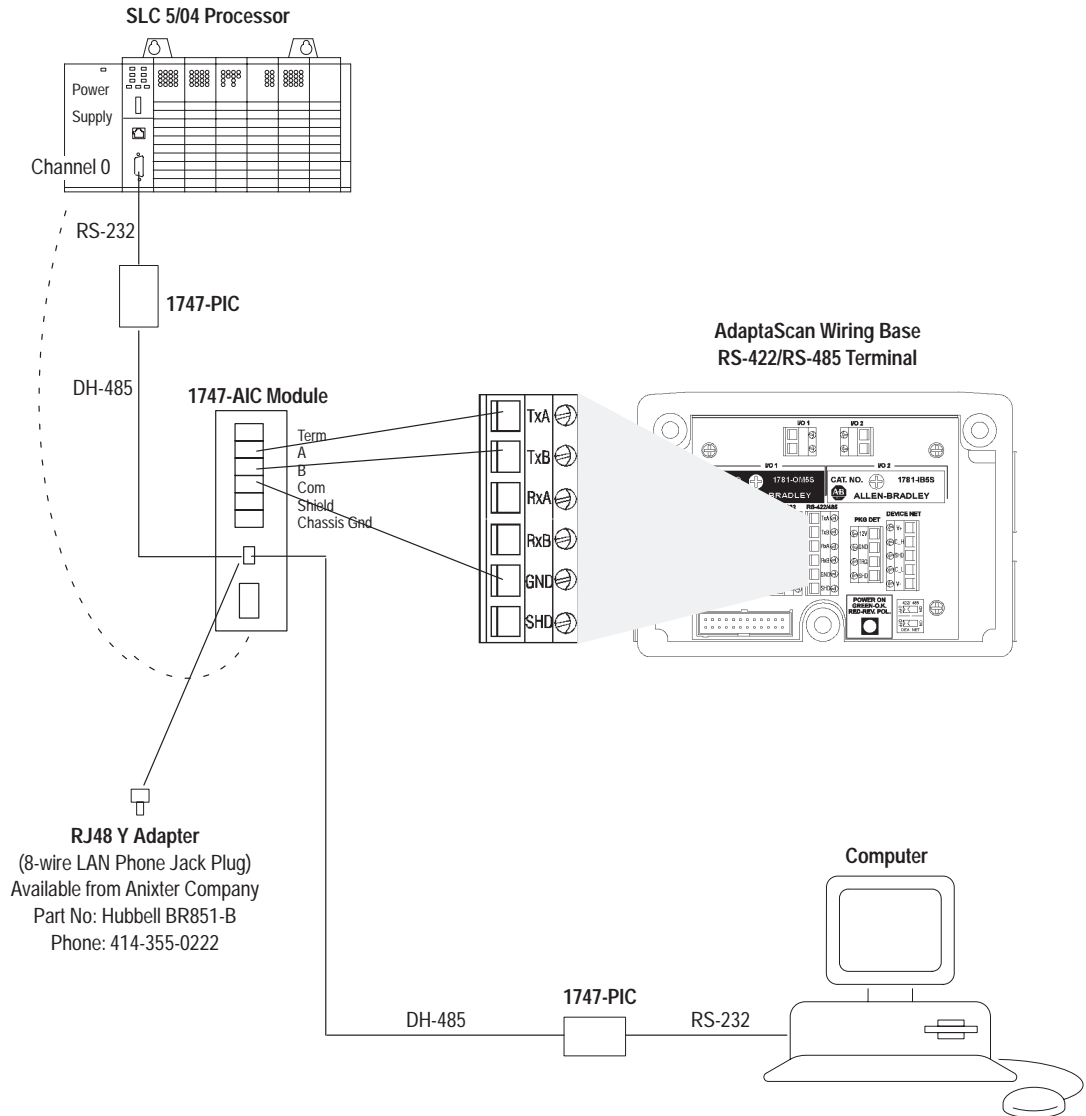

Configuring Bar Code Reader 1

This section shows how to configure one the AdaptaScan Bar Code Readers using the AdaptaScan Software (Catalog No. 2755-ASN).

The procedures in this section show how to:

- configure a bar code label and symbol
- define the DeviceNet node address of the AdaptaScan Reader
- configure the scanner
- configure the decoder trigger
- configure the serial port
- configure the format of messages and the message destination

The steps may vary for some procedures because of the different requirements of applications. For example, the bar code labels may vary from one application to the next.

Create a New Project

Create a new project named DH485 Match Code Download for the AdaptaScan Bar Code Readers.

1. Choose New from the Project menu to create a new project.
2. Click the New button to add a bar code reader (Bar Code Reader 1) to the project.



3. Choose Edit from the Project menu to rename the project **DH485 Match Code Download**.

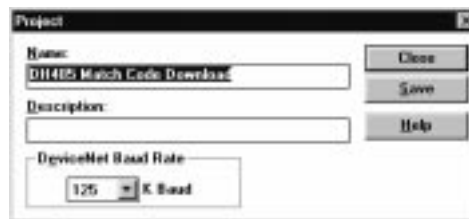

4. Click Save to save the project under the new name and then Close to return to the Project dialog.

Define the Bar Code Label

1. Click the Label button to open the Bar Code Labels dialog.

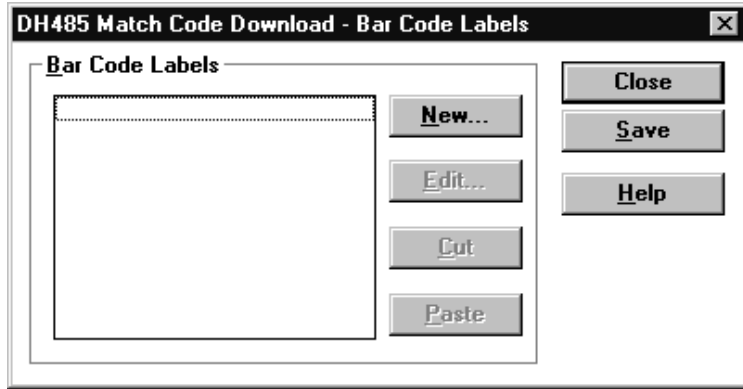

2. Click the New button to add a label to open the Bar Code Label dialog.

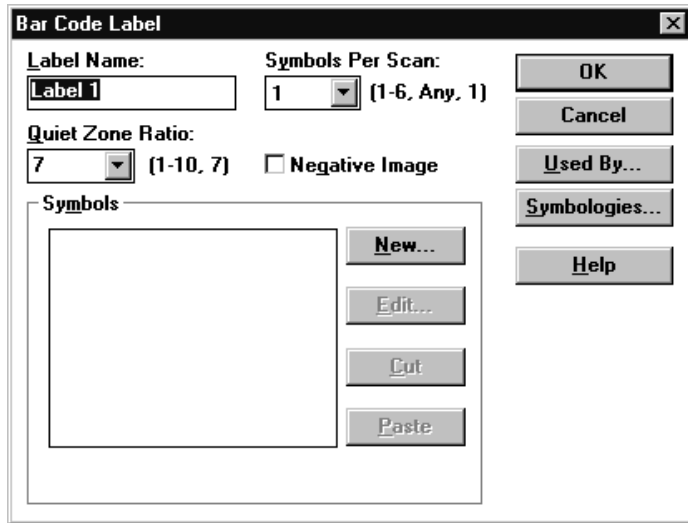

3. Click the New button to add a symbol.

4. Select a symbology and any other parameters (Identifier, Lengths) required by your application.

Bar Code Label Symbol

Name:

Symbology:

Identifier:

Include Identifier

Lengths

	From:	Through:	
<input type="checkbox"/> Length 1	1	64	(1-64)
<input type="checkbox"/> Length 2	1	64	(1-64)
<input type="checkbox"/> Length 3	1	64	(1-64)

Buttons: OK, Cancel, Help

5. Click OK to return to the main Project dialog.

Define the DeviceNet Address

1. Click the Device button to open the Device dialog.

DH485 Match Code Download - Bar Code Reader 1 - Dev...

Name:

Description:

DeviceNet Address: (0-63)

The Baud Rate is 125 K Baud.

Buttons: Close, Save, Apply, Help

2. Select a DeviceNet address.

Note: The DeviceNet address is not always the same as the DH-485 node address. A DH-485 node address is assigned later.

3. Connect the 2755-NC43 or -NC48 cable to the reader.
4. Click the Apply button.
5. Click Save and Close to return to the Project dialog.

Configure the Scanner

1. Click the Scanner button on the Project dialog to open the Scanner dialog.



2. Configure the scan pattern and use the Focus procedure for optimum scanner focus.
3. Click the Close button and return to the Project dialog.

Configure the Decoder Trigger

This application uses a Timer to trigger the reader's decoder. The Timer is typically used during application setup. Refer to Publication 2755-837 for other input sources that trigger the decoder.

1. Click the Decoder button from the main Project dialog.
2. Under Triggered By, select **Timer** from the Input list.

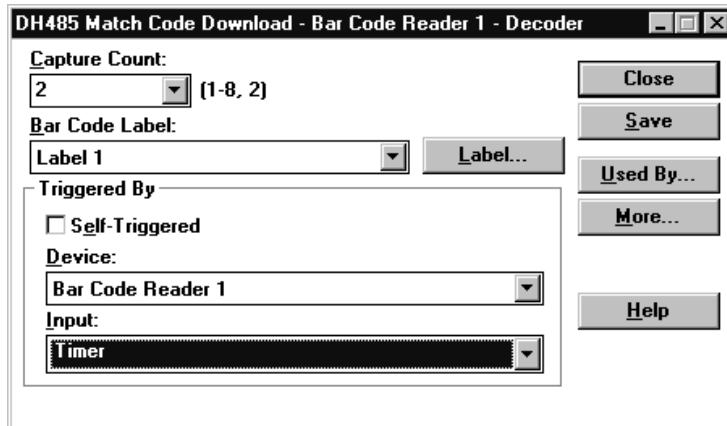

3. Click Save and Close to return to the main Project dialog.

Configure the Serial Port

1. Click the Serial Port button from the Project dialog.

The screenshot shows the 'DH485 Match Code Download - Bar Code Reader 1 - Serial Port' dialog box. The 'Protocol' dropdown is set to 'Terminal'. The 'Baud Rate' is set to '9,600'. The 'Maximum Length' is set to '0' with a range of '(0-1536, 0)'. The 'Scanner Protocol' checkbox is unchecked. Under 'Parity', 'None' is selected. Under 'Data Bits', '8' is selected. Under 'Stop Bits', '1' is selected. The 'Connection' dropdown is set to 'RS232'. In the 'Message Buffer' section, 'Enable Warning' is unchecked, 'Warning At' is set to '56', and 'Buffer Size' is set to '64'. There are empty dropdowns for 'Device:' and 'Output:'. At the bottom, the 'Enable Pass-Through to DeviceNet' checkbox is unchecked. Buttons for 'Close', 'Save', 'Used By...', 'Help', and 'Edit...' are visible.

2. Set the parameters as follows:
 - From the Protocol list box, select **DH-485**
 - From the Baud Rate list box, select **19,200**
 - Click the Scanner Protocol button
 - From the Connection list box, select **RS485**

The Serial Port must match the host configuration.

3. Click the Edit button to select *either* DH485 Slave Mode *or* DH485 Master Mode.

DH485 Slave Mode

1. Click the Protocol Edit button in the Serial Port dialog.

The screenshot shows the 'DH-485' configuration dialog box. It includes the following fields and controls:

- Node:** A dropdown menu showing '31' with a range of '(0-31)'.
- Maximum Node:** A dropdown menu showing '31' with a range of '(0-31)'.
- Destination:** A section containing:
 - Node:** A dropdown menu showing '0' with a range of '(0-31)'.
 - N9:Offset:** A text box containing '100' with a range of '(0-32765, 100)'.
- Master/Slave:** A section with two radio buttons: 'Slave' (which is selected) and 'Master'.
- PCCC Enabled:** A checked checkbox.
- Buttons:** 'OK', 'Cancel', and 'Help' buttons are located on the right side of the dialog.

2. Edit the parameters as follows:
 - Click the PCCC Enabled box
 - From the Master/Slave box, select **Slave**
 - From the Node box, select **2**
This is the DH485 node address.
3. Click OK to return to the main Serial Port dialog.
4. Click Save and Close to return to the main Project dialog.

DH485 Master Mode

1. Click the Protocol Edit button in the Serial Port dialog.

2. Set the parameters as follows:
 - From the Master/Slave box, select **Master**
 - From the Destination Node box, select **1**
This is the SLC node where the decoded bar codes are sent.
 - From the Maximum Node box, select **2**
This is the number of nodes on the network.
 - From the N9:Offset box, select **100** which is the default
This is the SLC destination address where the decoded bar codes are sent. N9: is reserved for communications. Bar code data is sent as an ASCII string to the SLC N9 file.
 - From the Node box, select **2**
This is the DH485 node address.

In this application the response in N9:100 will be 3F90 for a successful match code download or 3F94 for a match code download failure. (3F is the hexadecimal value of the AdaptaScan device address 63. This will be different for a different applied address.)

3. Click OK to return to the main Serial Port dialog.
4. Click Save and Close to return to the main Project dialog.

Configure for Match Codes

1. Click the Match Table button to open the Match Table dialog.

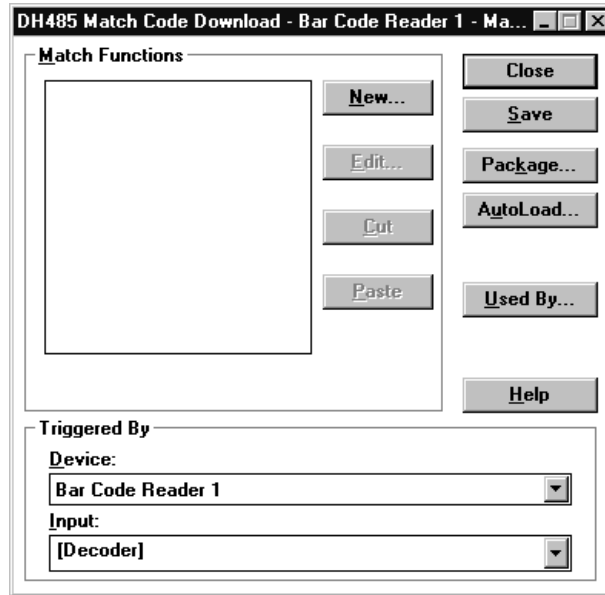

2. Click the New button to open the Match Function dialog and create a Match Function.

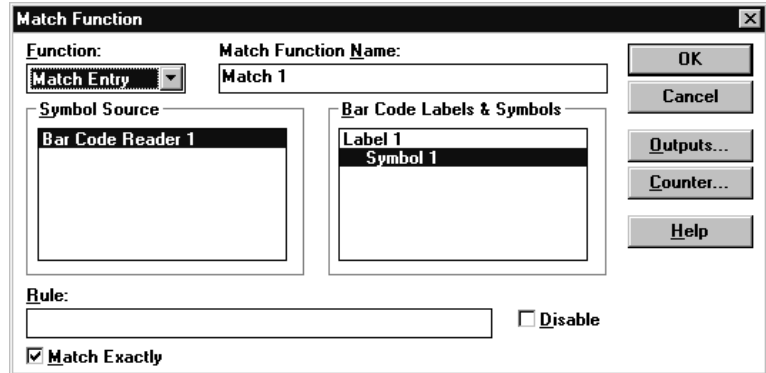

3. Under Function, select **Match Entry**.
Match Entry specifies that a match occurs whenever decoded bar code data matches the Rule: entry.
4. Under Symbol Source, select **Bar Code Reader 1**.
5. Under Bar Code Labels and Symbols, select **Symbol 1**.
6. Click the Match Exactly box.
Match Exactly specifies that ASCII characters are matched instead of a metacharacter rule.

- Click the Outputs button to specify which output activates when a match occurs.

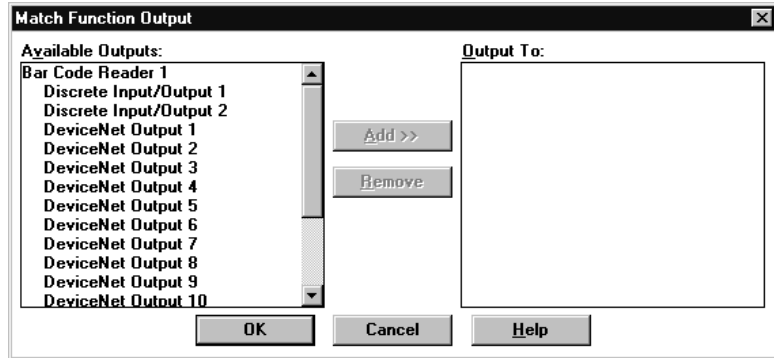

- Under Available Outputs, select **Discrete Input/Output 1**.
- Click the Add>> button to add this selection to the Output To: area.
- Click OK to return to the main Match Table dialog.

Configure for a Package

- Click the Package button to open the Package dialog.

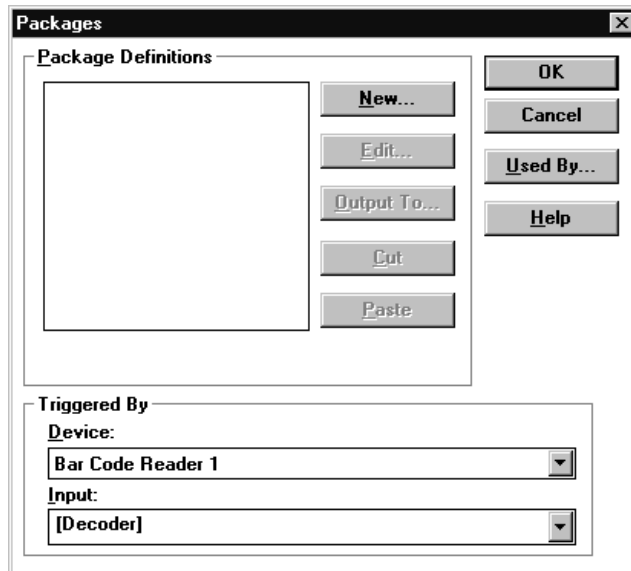

- Click the new button to create a Package.
- Under Mode, select **No-Read or No-Match**.

This mode is used to determine when a label is not read or does not match the rule defined in the Match function.

4. Highlight Match 1 to enable the Match function.

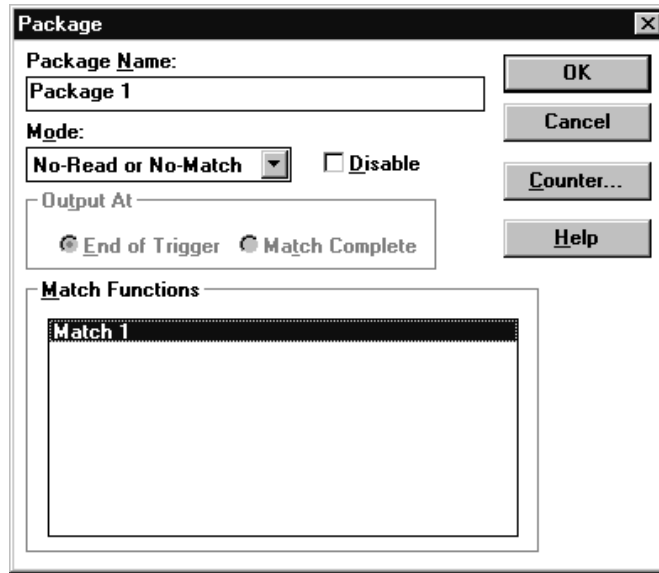

5. Click OK to return to the main Package dialog.

Configure for an Output

1. Click the Output To button to specify which output activates when a No-Read or No-Match occurs.

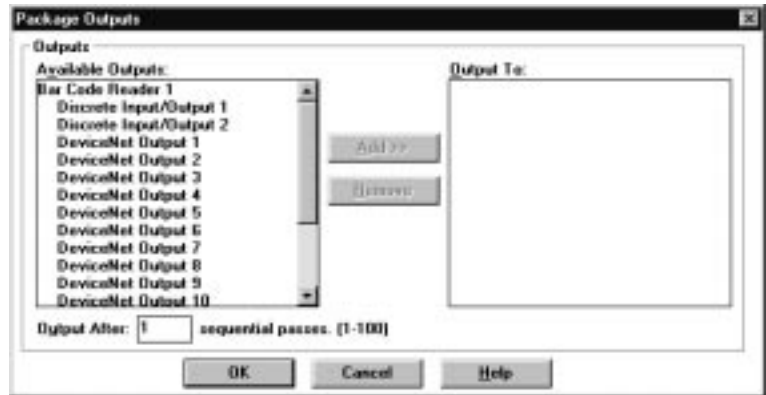

2. Under available Outputs, select **Discrete Input/Output 2**.
3. Click the Add>> button to add this selection to the Output To: area.
4. Click OK to return to the main Match Table dialog.
5. Click Save and Close to return to the Project dialog.

Sending the Configuration to the Reader

From the main Project dialog, click the Send Device button to download the configuration to the bar code reader.

Finding Match Table Instances

When you download match codes from a host, you need the instance number of the match table. Do not assume that Match 1 = Instance 1, Match 2 = Instance 2.

From the Project menu, select Print. The printout will show the class and instance numbers.



Project
Page 1 Wednesday, October 11, 1995 - 10:53 AM

Name	Class	Address/Instance
Bar Code Reader 1		63
Match 1	206	1
Match 3	206	3
Match 4	206	4
Match 2	206	5
Match 5	206	6
Field 1	204	1

Downloading Match Codes

To download match codes from the SLC you must:

1. Convert the match string to hex.
2. Enter the match string in the proper data packet format (byte swapped).
3. Send the data packet (containing the string) to the reader.

Convert the Bar Code String to Hex

Convert the bar code string you want to send to the reader to the hexadecimal ASCII equivalent value. For example:

Bar Code String:

0	3	0	0
---	---	---	---

Converted Hex Value:

30	33	30	30
----	----	----	----

Converted Bar Code Length Value:

0	4	0	0
---	---	---	---

In the bar code length value shown above, if the number of characters 04 were changed to 14, the hexadecimal value would be 0E. This hexadecimal value is written as 0E00.

Place the String in the Data Packet

The bar code string is sent in a data packet having this format:

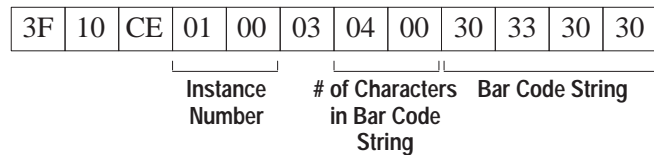

The following are descriptions of the data packet:

- 3F = DeviceNet Address (3F= 63, each reader has unique address)
- 10 = Set attribute (single request)
- CE = 206 = Class (always 206 for match table)
- 01 = Instance Number (LSB)
- 00 = Instance Number (MSB)
- 03 = Attribute Number – Rule
- 04 = Length of String (LSB)
- 00 = Length of String (MSB)
- 30 = ASCII “0”
- 33 = ASCII “3”
- 30 = ASCII “0”
- 30 = ASCII “0”

Note: You can use the Windows calculator to convert decimal values to hexadecimal.

Response Codes

Response codes have the following format:

Byte	Contents
0	Mac ID (Address)
1	94 = Error Response
2	x = General Error Code
3	x = Additional Code

General Error Codes

Code (hex)	Name
02	Resource unavailable
08	Service not supported
09	Invalid attribute value
0B	Already in requested mode/state
0C	Object cannot perform service in its current mode/state
0E	Attribute not settable
0F	Access permission does not allow service
10	Device's mode/state does not allow object to perform service
11	Reply data too large
13	Not enough data
14	Attribute not supported
15	Too much data
16	Object does not exist
18	No stored attribute data
19	Store operation failure
D0-FF	Class specific

Configuring the SLC Controller

This section describes how to configure the SLC 5/04, which is different than the 5/03.

- Using APS and an RS-232 connection, establish an online connection the Channel 0 port of the SLC 5/04.
- When online, change to DH485 protocol and do a WHO ACTIVE to view the nodes on the network.

For complete details on configuring the SLC 5/04 or 5/03 processors, refer to the Advanced Programming Software manuals.

SLC 5/04 Configuration

1. Establish communication with the Channel 0 port of the SLC 5/04 using the 1747-CP3/A RS-232 cable.

```
Default
On line configuration
DF1 Full-Duplex
No Handshaking
F7 1200
CRC Error Check
Duplicate Detention
No Parity
Enter (twice)
On line (in RS-232)
```

2. Verify that you are online in "REM RUN".

```
Change configuration driver F2 - PIC
Baud Rate 19,200
Max Node 2
F7 Utility
F5 Channel 0 (Master Mode)
Power down and up
```

SLC Ladder Logic

This section describes how to view match codes

- in Slave Mode via the reader’s LEDs
- in Slave Mode via ladder logic
- in Master Mode via ladder logic

Viewing Match Codes in Slave Mode via the Reader’s LEDs

Use a MSG Write command to download the Match Code Hex commands. The enable bit is toggled [F9] in order to make the download transition. The AdaptaScan I/O LED’s will indicate a good match or a No-Read or No-Match.

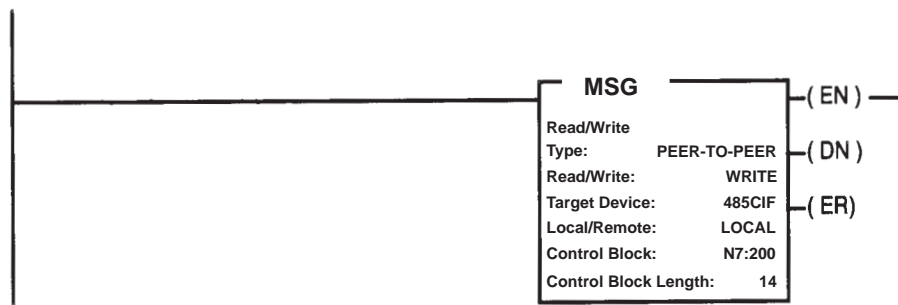

Message Instruction Configuration

Parameter	Configuration
Type	Peer-to-Peer
Read/Write	Write
Target Device	485CIF
Local/Remote	Local
Control Block	N7:200
Channel	0
Target Node	2
Destination File Access	N7:90
Target Offset	255 (Change 255 to 256 or 100H in the third word of the Control Block. An offset greater than 255 tells the MSG instruction that the SLC controller is talking to a bar code device.)
Message Length in Elements	10
Message Timeout (seconds)	10

Place the Match Code Hex command (Byte Swapped) in the Destination File Address N7:90.

- example bar code string = 0300
- 0300 converted to hex = 30333030
- ASCII Hex command = 3F10CE010003040030333030

Byte Location		0	1	2	3	4	5
Byte Swapped	N7:90	103F	01CE	0300	0004	3330	3030

You can verify whether or not a correct match code was downloaded by placing a bar code label in front of the reader so that it is scanned. Observe the Output LED's on the top of the reader. When the downloaded match code matches a scanned label, the Output 1 will turn on, otherwise Output 2 will turn on (for no read or no match).

Viewing Match Code Downloads in Slave Mode via Ladder Logic

Use the following SLC ladder logic for DH485 Slave Mode if the AdaptaScan I/O LEDs cannot be used for viewing.

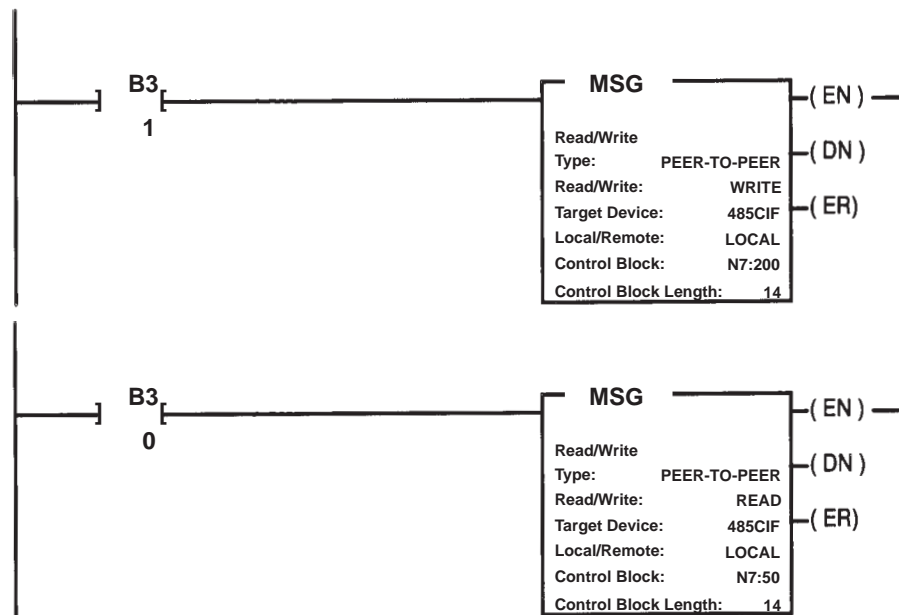

Note: You can only initiate one read or one write at a time. Reads and writes should never be initiated at the same time.

Message Instruction Configurations

For the first Message Instruction, the configuration is listed in the table below.

Parameter	Configuration
Type	Peer-to-Peer
Read/Write	Write
Target Device	485CIF
Local/Remote	Local
Control Block	N7:200
Channel	0
Target Node	2
Destination File Access	N7:90
Target Offset	255 (Change 255 to 256 or 100H in the third word of the Control Block. An offset greater than 255 tells the MSG instruction that the SLC controller is talking to a bar code device.)
Message Length in Elements	10
Message Timeout (seconds)	10

For the second Message Instruction, the configuration is listed in the table below.

Parameter	Configuration
Type	Peer-to-Peer
Read/Write	Read
Target Device	485CIF
Local/Remote	Local
Control Block	N7:50
Channel	0
Target Node	2
Destination File Access	N7:80
Target Offset	255 (Change 255 to 256 or 100H in the third word of the Control Block. An offset greater than 255 tells the MSG instruction that the SLC controller is talking to a bar code device.)
Message Length in Elements	2
Message Timeout (seconds)	0

Place the Match Code Hex command (Byte Swapped) in the Destination File Address N7:90.

- example bar code string = 0300
- 0300 converted to hex = 30333030
- ASCII Hex command = 3F10CE010003040030333030

Byte Location		0	1	2	3	4	5
Byte Swapped	N7:90	103F	01CE	0300	0004	3330	3030

In Slave Mode, file N7:80 will contain the response for a successful download (i.e. 3F90) or failure (i.e. 3F94).



Note: The response cannot be displayed at the same time as the match code download. For this reason, an Examine If Close (XIC) contact B3:0 is used to control when the response is requested.

Viewing Match Code Downloads in Master Mode via Ladder Logic

Use the following SLC ladder logic for DH485 Master Mode if the AdaptaScan I/O LEDs cannot be used for viewing.

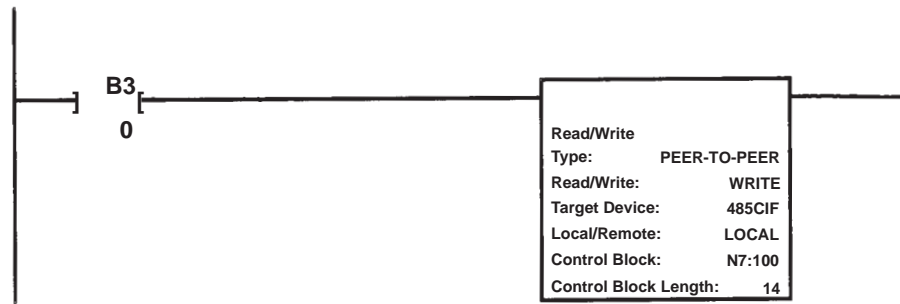

Message Instruction Configuration

Parameter	Configuration
Type	Peer-to-Peer
Read/Write	Write
Target Device	485CIF
Local/Remote	Local
Control Block	N7:100
Channel	0
Target Node	2
Destination File Access	N7:200
Target Offset	255
Message Length in Elements	10
Message Timeout (seconds)	10

Place the Match Code Hex command (Byte Swapped) in the Destination File Address N7:200.

- example bar code string = 0300
- 0300 converted to hex = 30333030
- ASCII Hex command = 3F10CE010003040030333030

Byte Location		0	1	2	3	4	5
Byte Swapped	N7:200	103F	01CE	0300	0004	3330	3030

In Master Mode, the N9:offset file will contain the response for a successful download (i.e. 3F90) or failure (i.e. 3F94). The offset address (such as N9:100) is configured in the AdaptaScan OLP software (DH485 dialog box). This offset can be any value from N9:00 to N9:255.

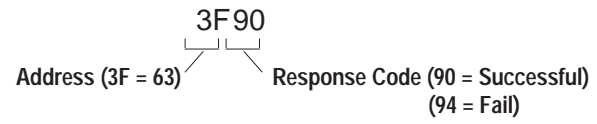

Communicating with a 1746-BAS BASIC Module

Overview

This application describes how to connect and configure an AdaptaScan Bar Code Reader to communicate with an SLC 500 processor using the 1746-BAS BASIC module. The bar code reader is reading a 4 character Interleaved 2 of 5 symbol with a <cr> for the message trailer.

The application includes cable diagrams and configuration information for the AdaptaScan Reader. It also includes a sample SLC 500 program which is needed to establish communications through the RS-232 port of the SLC 5/03 (Frn 6.0) or 5/04.

Hardware Requirements

The hardware items required for this application are:

- 2755-SN3, -SN5 or -SN8 AdaptaScan Bar Code Reader
- 2755-NB40 or -NB41 Wiring Base
- 2755-PW46 or -PW47 Power Supply
- 2755-NC43 or -NC48 Configuration Cable
- 1746 SLC 500 Processor
- 1747 chassis
- 1746 power supply
- 1746-BAS BASIC module
- 1746-PIC RS-232/DH-485 convertor or 1761-AIC+
- Computer running Windows 3.1 (or later) or Windows 95
- 9-to-25 Pin Adapter (for computer with a 25-pin COM port)

Software Requirements

The software requirements for this application are:

- 2755-ASN AdaptaScan Offline Programming Software
- 9323-PA2x Advanced Programming Software

Related Publications

Publications you might want to refer to include:

Publication	Description
2755-837	AdaptaScan Bar Code Readers User Manual
2755-838	AdaptaScan Software User Manual
1746-6.2	BASIC Development Software Programming Manual
1746-6.3	BASIC Language Reference Manual

In addition, you may want to refer to the SLC 500 Hardware and Software User Manuals.

Connecting a BASIC Module to the Reader

The SLC 500 processor occupies the first slot in a 1747 chassis. Power is supplied externally to the 1747 chassis.

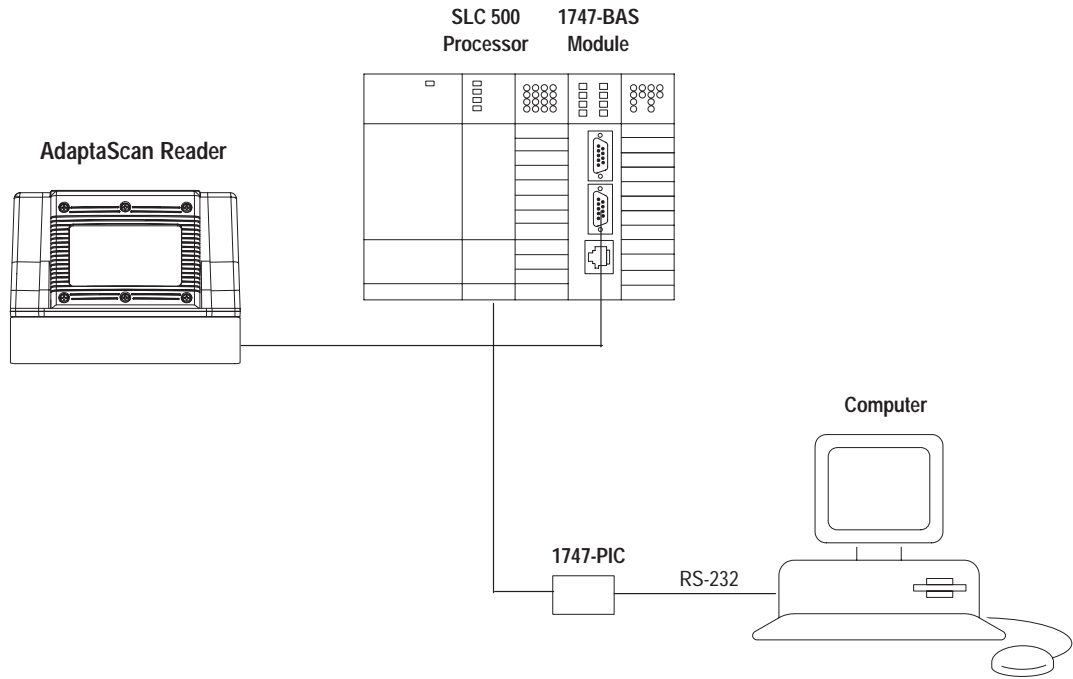

AdaptaScan Wiring Base RS232 Terminal Strip	RS-232 Cable Pinouts	BASIC Module User Port 2
PIN		PIN
RX	—————	2
TX	—————	3
GND	—————	5

SLC Ladder Logic

This section provides the SLC ladder logic program for CALL 22. The BASIC module is located in slot 1 of the SLC chassis. The SLC 500 processor is located in slot 0.

At rung 2.0, data is copied from the M1 file when the handshake bit (I:1.0/8) is set by the BASIC module. The SLC processor sets the handshake bit (O:1.0/8) once the data has been copied out of the M1 file. Setting the bit triggers the BASIC module to turn off bit I:1.0/8. The first word of the M1 file contains the byte count and this word is not included in the data byte count. The following ladder logic program example has a maximum of 6 bytes of data. I:1.0/8 is the handshake bit from the BASIC module to the SLC processor. O:1.0/8 is the handshake bit from the SLC processor to the BASIC module.

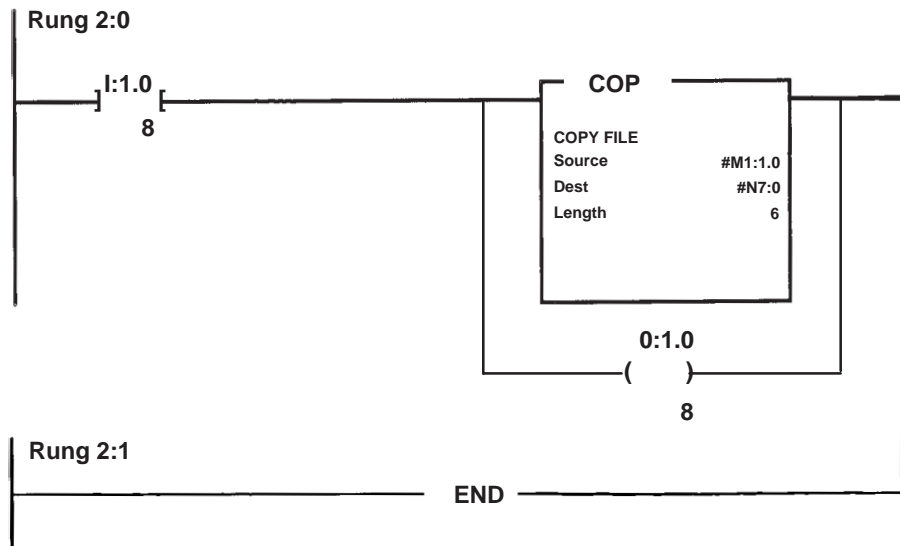

Programming the BASIC Module

Refer to the following steps to program the BASIC module.

1. Make sure the BASIC Development Software is loaded onto your personal computer. Refer to the *BASIC Development Software Programming Manual* (Publication No. 1746-6.2) for downloading information.
2. Create a project file.
3. Type in the following program. This program will port 2 of the BASIC module to receive data and then send the data to the SLC M1 file.

```
10  PUSH 2   REM PRT2 ACTIVE FOR CALL 22
20  PUSH 6   REM PORT RECEIVING 6 BYTES OF DATA
30  PUSH 13  REM USE A <CR> FOR A TERMINATOR
40  PUSH 1   REM SEND DATA TO THE M1 FILE
50  PUSH 0   REM OFFSET TO M1 FILE
55  PUSH 0   REM STRING NUMBER - NOT USED
60  PUSH 1   REM BYTE SWAPPING ENABLED
70  CALL 22  REM IMPLEMENT CALL STATEMENT
80  POP X    REM STATUS OF CALL 22 INSTRUCTION
90  END
```

4. Press F1 to save the program.
5. Press Esc to return to the Main Menu.
6. Select Terminal [RS-232]. Press Enter.
7. Press F2. Select setup. Select Autobaud. Select Yes. The default baud rate (1200) should appear.
8. Press F2. Select setup. Select Com Port settings. Verify that your communication port settings are correct.
9. Press Enter.
10. Press Enter to save your setup.
11. Press F2.
12. Press Enter.
13. Connect your PC to the BASIC module.
14. Select Download from host to module. Press Enter. Type in the name of your program (from step 4). Press Enter. Your program should now appear on the screen.
15. Type Run and press Enter. Ready should appear on your screen indicating the program ran successfully.

SLC BASIC Module Code

Refer to the partial BASIC program listed below to in order for port 2 of the BASIC module to receive data and then send the data to SLC M1 file.

```

10  PUSH 2    REM PRT2 ACTIVE FOR CALL 22
20  PUSH 6    REM PORT RECEIVING 6 BYTES OF DATA
30  PUSH 13   REM USE A <CR> FOR A TERMINATOR
40  PUSH 1    REM SEND DATA TO THE M1 FILE
50  PUSH 0    REM OFFSET TO M1 FILE
55  PUSH 0    REM STRING NUMBER - NOT USED
60  PUSH 1    REM BYTE SWAPPING ENABLED
70  CALL 22   REM IMPLEMENT CALL STATEMENT
80  POP X     REM STATUS OF CALL 22 INSTRUCTION
90  END

```

Make sure that the serial port of the BASIC module is set up the same as the AdaptaScan serial port.

Configuring the Reader

This section shows how to configure the AdaptaScan Reader using the AdaptaScan software.

The procedures listed in this section show how to:

- configure a bar code label and symbol
- configure the scanner
- configure the decoder trigger
- configure the serial port
- configure the format of messages and the message destination

Create a New Project

Create a new project named 1746 BASIC Module for the AdaptaScan Bar Code Reader.

1. Choose New from the Project menu to create a new project.
2. Click the New button to add a bar code reader (Bar Code Reader 1) to the project.



3. Choose Edit from the Project menu to rename the project **1746 BASIC Module**.

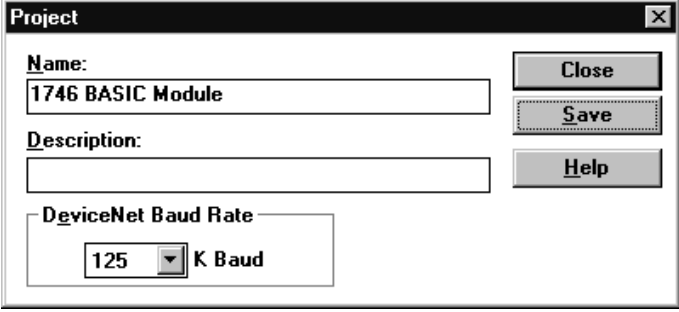

The screenshot shows a dialog box titled "Project" with a close button (X) in the top right corner. The dialog contains the following elements:

- Name:** A text input field containing "1746 BASIC Module".
- Description:** An empty text input field.
- DeviceNet Baud Rate:** A dropdown menu showing "125" and "K Baud".
- Buttons:** Three buttons are located on the right side: "Close", "Save" (with a dotted border), and "Help".

4. Click Save to save the project under the new name and then Close to return to the Project dialog.

Define the Bar Code Label

1. Click the Labels button to open the Bar Code Labels dialog.
2. Click the New button to define a label.

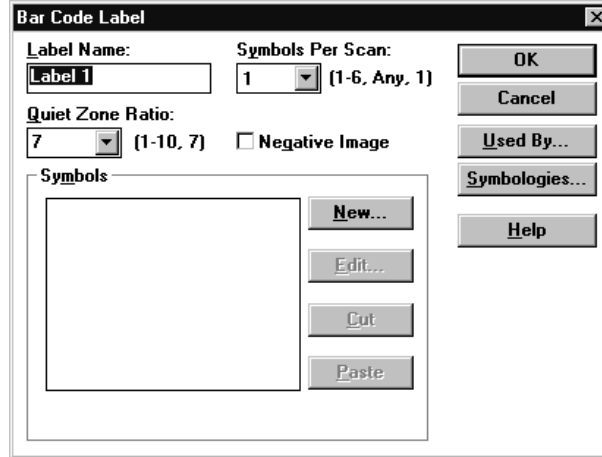

3. Click the New button to define a symbol for the label.

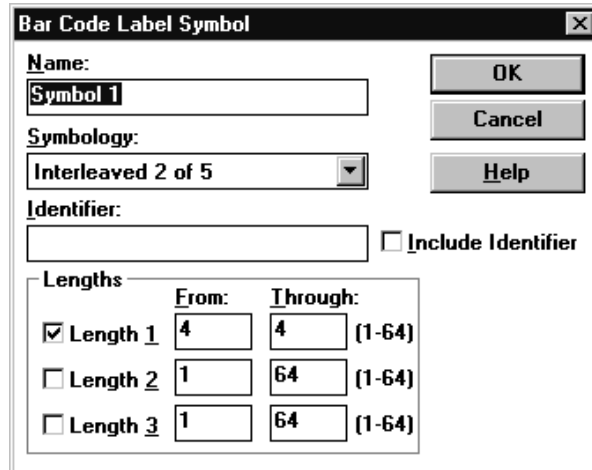

4. Select the symbology and define attributes such as Identifier and Lengths.
5. Click OK until you return to the Bar Code Labels dialog.
6. Click Save and then Close to return to the main Project dialog.

Define the DeviceNet Address

1. Click the Device button to open the Device dialog.

1746 BASIC Module - Bar Code Reader 1 - Device

Name:

Description:

DeviceNet

Address: (0-63)

The Baud Rate is 125 K Baud.

2. Select a DeviceNet address.

Note: The DeviceNet address is not always the same as the DH-485 node address. A DH-485 node address is assigned later.

3. Connect the 2755-NC43 or -NC48 cable to the reader.
4. Click the Apply button.
5. Click Save and Close to return to the Project dialog.

Configure the Scanner

1. Click the Scanner button on the Project dialog to open the Scanner dialog.

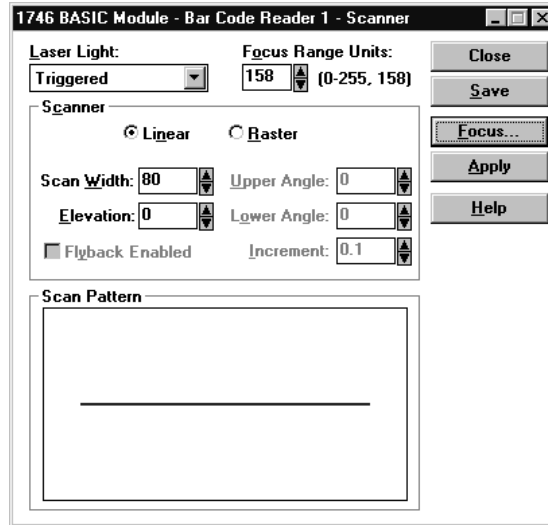

2. Configure the scan pattern and use the Focus procedure for optimum scanner focus.
3. Click the Close button and return to the Project dialog.

Configure the Decoder Trigger

This application uses a Timer to trigger the reader's decoder. The Timer is typically used during application setup. Refer to Publication 2755-837 for other input sources that trigger the decoder.

1. Click the Decoder button from the main Project dialog.
2. Under Triggered By, select **Timer** from the Input list.

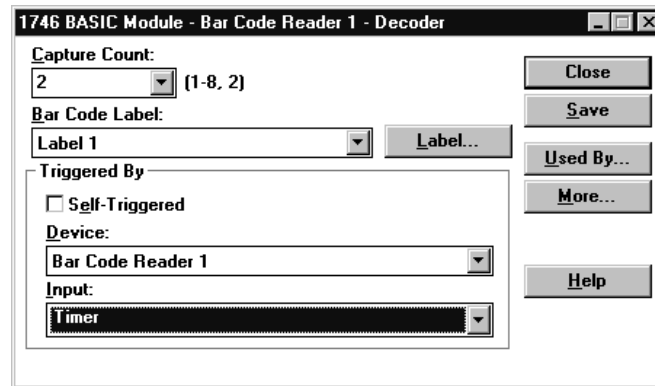

3. Click the Save button.
4. Click the Close button and return to the main Project dialog.

Configure the Serial Port

1. Click the Serial Port button from the Project dialog.

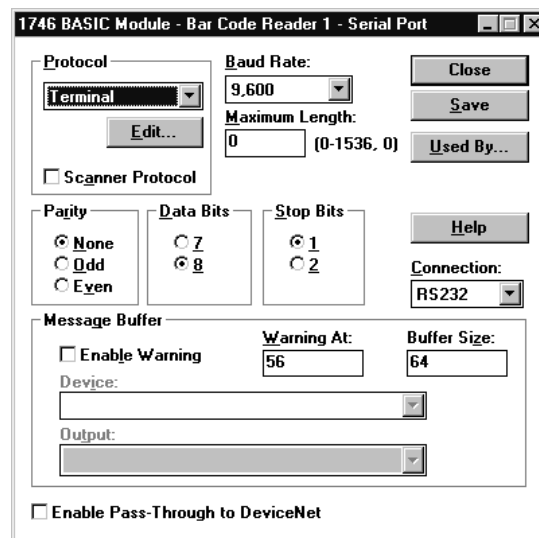

2. Configure the serial port as follows:
 - From the Protocol list box, select **Terminal**
 - From the Connection list box, select **RS232**

The configuration must match the host configuration.

3. Click Save and then Close to return to the main Project dialog.

Create a Message

Data sent from the AdaptaScan Reader to the BASIC module uses messages.

1. Click the Message button from the main Project dialog.

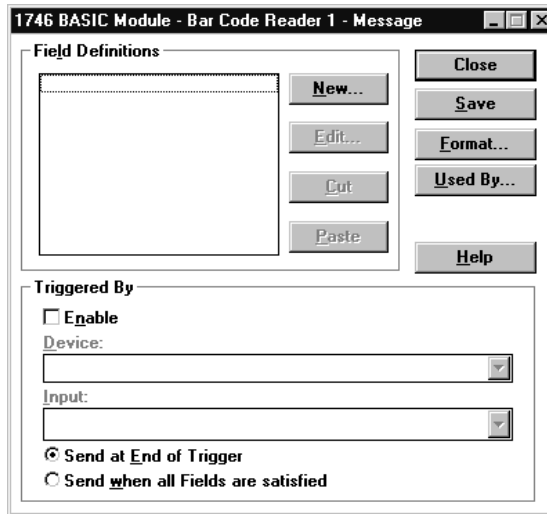

2. Under Triggered By, check the Enable check box.
3. Under Device, select **Bar Code Reader 1**.
4. Under Input, select **[Decoder]**.
5. Click the New button to create a message field.

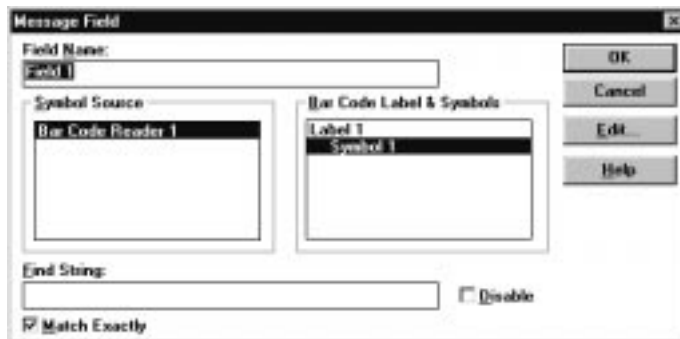

6. Under Symbol Source, select **Bar Code Reader 1**.
7. Under Bar Code Labels & Symbols, select **Symbol 1**.

8. Check (enable) the Match Exactly check box.
9. Click the Edit button to open the Message Field Edit dialog.

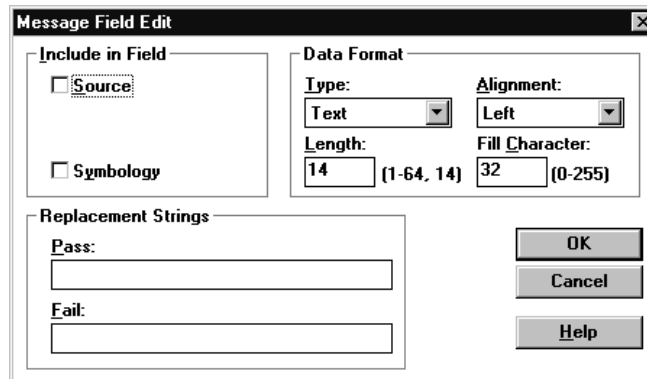

10. Under Replacement Strings, type **nr** in the Fail: box.

Bar code data is sent to the BASIC module at end of a trigger. The Fail string sends “nr” to the BASIC module when a no read occurs.

Note: Enter **4** in the Length field of the Data Format. The length parameter must be set to the number of characters in the bar code symbol. The number 4 is chosen because a 4 character I 2 of 5 symbol is being read.

11. Click OK to return to the Message Field dialog.
12. Click OK again to return to the Message dialog.

Define the Message Format

1. Click the Format button from the Message dialog.

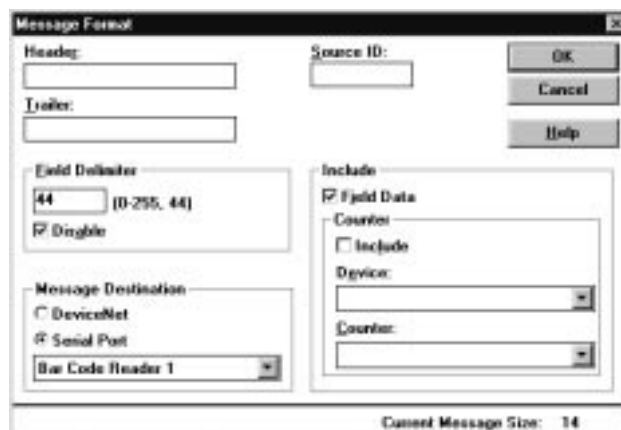

2. In the Trailer text box, type **\r\n**.
3. Under Message Destination, select **Serial Port**.
4. Click OK to return to the Message dialog.

5. Click Save and then Close to return to the Project dialog.

Sending the Configuration to the Reader

From the main Project dialog, click the Send Device button to download the configuration to the bar code reader.

Running the Application

If the AdaptaScan Bar Code Reader is configured correctly and the BASIC module and SLC programs are entered as shown in this application example, bar code data or “nr” appears in the SLC processor M1 file.

Communicating with an SLC™ over an RS-232 Link

Overview

This application describes how to connect and configure an AdaptaScan Bar Code Reader to communicate with an SLC 5/03 or SLC 5/04 processor using an RS-232 serial connection.

The application includes cable diagrams and configuration information for the AdaptaScan Readers. It also includes a sample SLC 500 program which is needed to establish communications through the RS-232 port of the SLC 5/03 (Frn 6.0) or 5/04.

Hardware Requirements

The hardware items required for this application are:

- 2755-SN3, -SN5 or -SN8 AdaptaScan Bar Code Reader
- 2755-NB40 or -NB41 Wiring Base
- 2755-PW46 or -PW47 Power Supply
- 2755-NC43 or -NC48 Configuration Cable
- 1746 SLC 5/03 Enhanced (Frn 6.0) or 5/04 Processor
- 1747 chassis
- 1746 power supply
- 1747-PIC module for communication between the processor and a personal computer
- appropriate cables to program the SLC 5/03 or 5/04
- Computer running Windows 3.1 (or later) or Windows 95
- 9-to-25 Pin Adapter (for computer with a 25-pin COM port)

Software Requirements

The software requirements for this application are:

- 2755-ASN AdaptaScan Offline Programming Software
- 9323-PA2x Advanced Programming Software

Related Publications

Publications you might want to refer to include:

Publication	Description
2755-837	AdaptaScan Bar Code Readers User Manual
2755-838	AdaptaScan Software User Manual

In addition, you may want to refer to the SLC 500 Hardware and Software User Manuals.

Connecting an SLC Controller to the Reader

The SLC 5/03 or 5/04 occupies the first slot in a 1747 chassis. Power is supplied externally to the 1747 chassis.

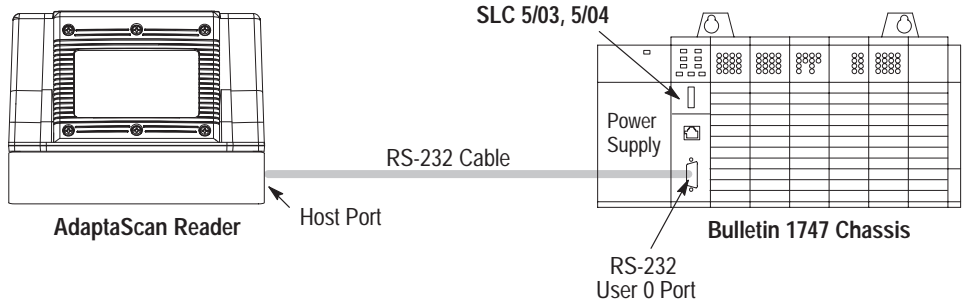

AdaptaScan Wiring Base RS232 Terminal Strip	RS-232 Cable Pinouts	SLC 500 User Port 0
PIN		PIN
RX	—————	3
TX	—————	2
GND	—————	5

Configuring the SLC Controller

The screens in this section show the software configuration for the SLC 5/03 or 5/04 using the APS Programming Software.

- Set the SLC 500 Channel 0 to **USER** in the Channel Configuration Screen.

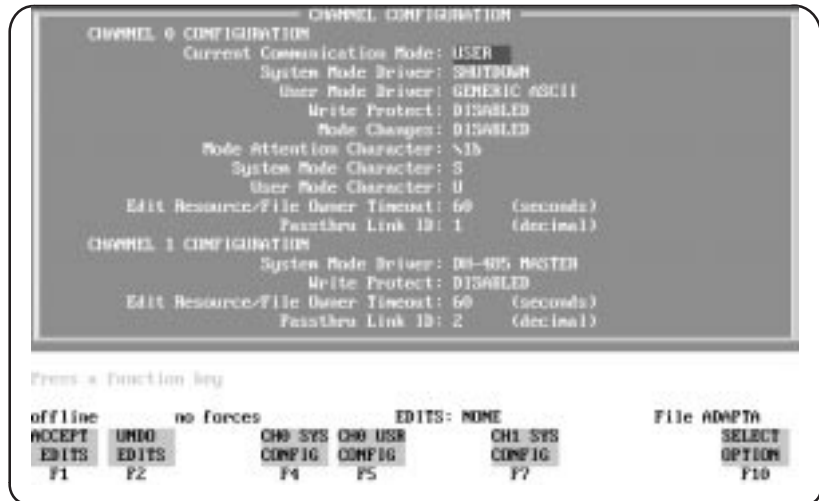

- Configure Channel 0 in the Channel 0 User Mode Configuration screen.



Note: Termination 1 is set for \n or Carriage Return [CR], and Termination 2 is set for \a or Line Feed [LF]. These terminators, along with the **ARL** instruction in the SLC 500, allow the User port to read in one message at a time with [CR][LF] terminators.

SLC Ladder Logic Program

The sample ladder logic below instructs the SLC 5/03 or 5/04 to read one string of ASCII data terminated with [CR][LF].

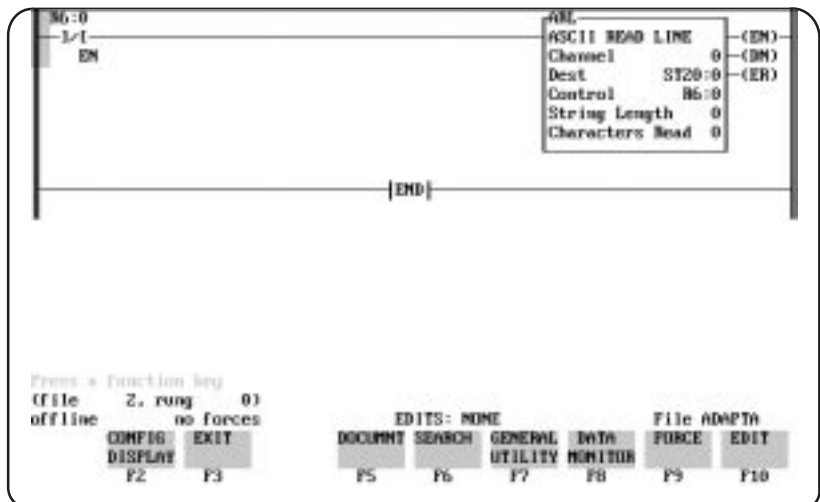

Refer to the SLC 5/03 user manual for detailed information on using the SLC 5/03 or 5/04 programming software including the ASCII instructions.

Configuring the Reader

This section shows how to configure the AdaptaScan Bar Code Reader using the AdaptaScan Software (Catalog No. 2755-ASN).

The procedures in this section show how to:

- configure a DeviceNet address
- configure a bar code label and symbol
- configure the scanner
- configure the decoder trigger
- configure the serial port
- configure the content and format of messages

These procedures provide general guidelines for setting up an application. You may need to modify the configuration for your application needs.

Create a New Project

Create a new project named SLC for one AdaptaScan Bar Code Reader (Bar Code Reader 1).

1. Choose New from the Project menu to create a new project.
2. Click the New button to add a bar code reader (Bar Code Reader 1) to the project.

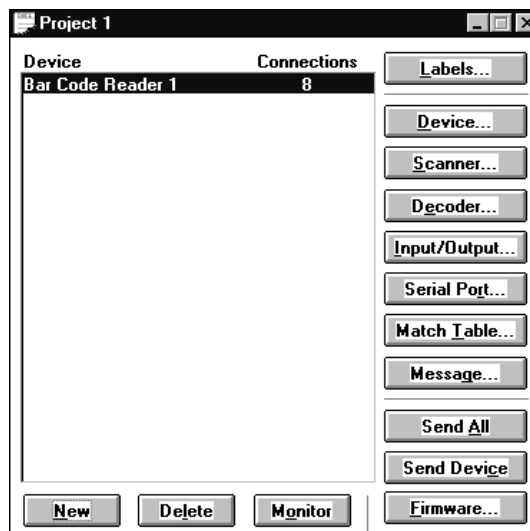

3. Choose Edit from the Project menu to rename the project SLC.

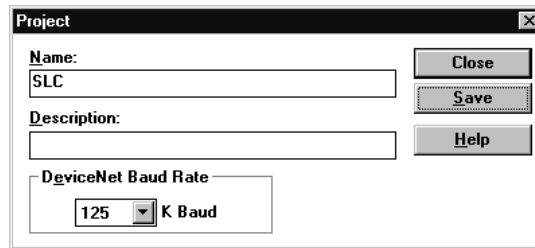

4. Click Save to save the project under the new name and then Close to return to the Project dialog.

Define the Bar Code Label

1. Click the Labels button to open the Bar Code Labels dialog.
2. Click the New button to define a label.

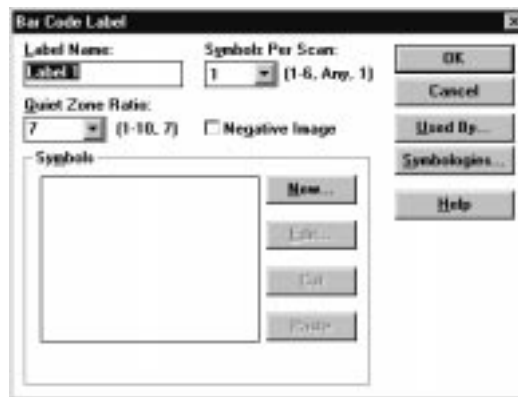

3. Click the New button to define a symbol for the label.

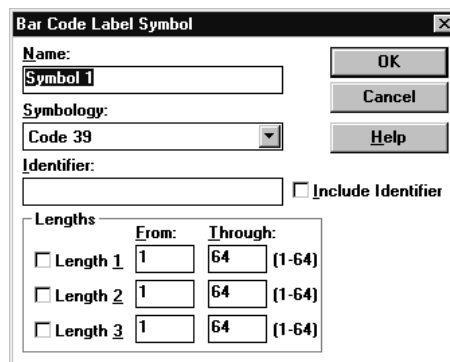

4. Select a symbology and any other parameters (Identifier, Lengths) required by your application.
5. Click OK until you return to the Bar Code Labels dialog.
6. Click Save and then Close to return to the main Project dialog.

Define the DeviceNet Address

1. Click the Device button on the Project dialog.



2. Set the DeviceNet address.
3. Connect the 2755-NC43 or -NC48 Configuration Cable to the reader.
4. Click the Apply button.
5. Click Save and Close to return to the Project dialog.

Configure the Scanner

1. Click the Scanner button on the Project dialog to open the Scanner dialog.

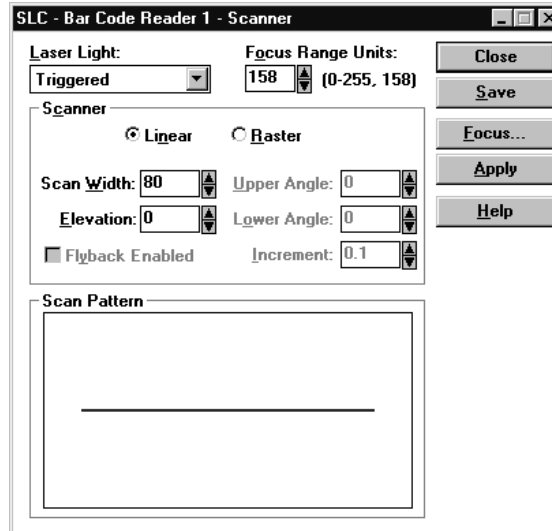

2. Configure the scan pattern and use the Focus procedure for optimum scanner focus.
3. Click the Close button and return to the Project dialog.

Configure the Decoder Trigger

This application uses a Timer to trigger the reader's decoder. The Timer is typically used during application setup. Refer to Publication No. 2755-837 for other input sources that trigger the decoder.

1. Click the Decoder button from the main Project dialog.
2. Under Triggered By, select **Timer** from the Input list.



3. Click the Save button.

Configure the Serial Port

1. Click the Serial Port button on the main Project dialog.

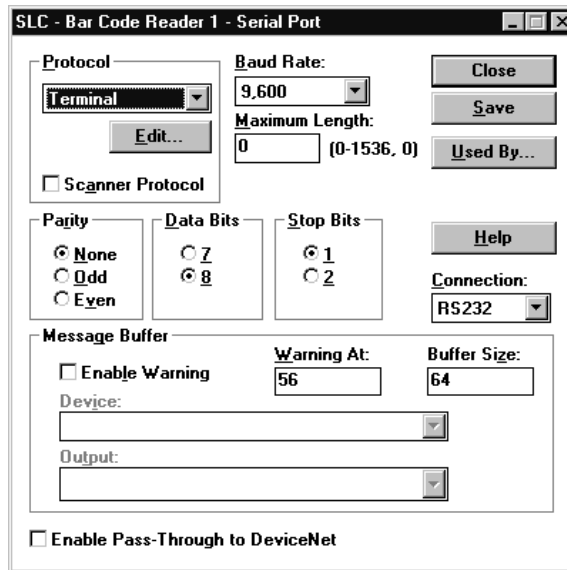

2. Verify that **Terminal** is selected in the Protocol list box. Also verify that the settings match the Channel 0 User settings.
3. Click the Edit button to open Terminal dialog.
4. Set the attributes as necessary.

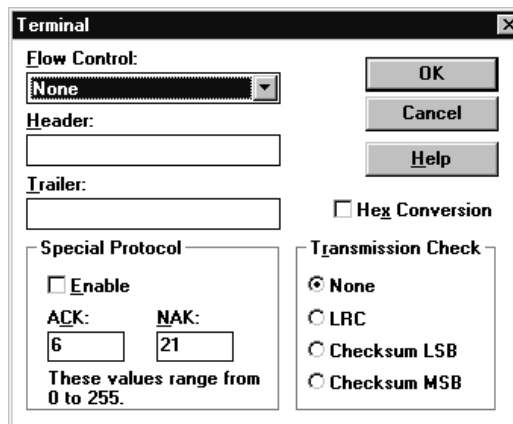

5. Click OK to exit the dialog.
6. Click the Save and then the Close button on the Serial Port dialog to return to the main Project dialog.

Create a Message

The Message dialogs define the format and content of message data sent to the host by the reader when bar codes are decoded.

1. Click the Message button from the main Project dialog.
2. Under Triggered By, check the Enable check box.



3. Under Device, select **Bar Code Reader 1**.
4. Under Input, select **[Decoder]**.
5. Click the New button to define a message field.



6. Under Symbol Source, select **Bar Code Reader 1**.
7. Under Bar Code Labels & Symbols, select **Symbol 1**.
8. Check (enable) the Match Exactly check box.
9. Click the Edit button to open the Message Field Edit dialog.

- Under Replacement Strings, type **no read** in the Fail: field.

Bar code data is sent to the controller on a valid read. The Fail string sends the characters “no read” when a no read occurs.



- Click OK to return to the Message Field dialog.
- Click OK to return to the Message dialog.

Define the Message Format

The format of the message is defined below.

- Click the Format button from the Message dialog.
- In the Trailer field, type `\r\n` (Carriage Return, Line Feed).
- Under Message Destination, select **Serial Port**.



- Click OK to return to the Message dialog.
- Click the Save button and then the Close button to return to the main Project dialog.

Sending the Configuration to the Reader

From the main Project dialog, click the Send Device button to download the configuration to the bar code reader.

Use the Monitor dialog to verify the decoding of bar code labels.

Running the Application

If the AdaptaScan Bar Code Reader is configured correctly and the SLC programs are entered as shown in this application example, bar code data or “no read” will be sent to the SLC user port.

Communicating with an SLC on a DH-485 Network

Overview

This application describes how to connect and configure two AdaptaScan Bar Code Readers to communicate with an SLC 5/03 or 5/04 processor over a DH-485 network in a master mode.

The DeviceNet network has the following nodes:

- SLC 5/03 or 5/04 on node 1
- AdaptaScan Bar Code Reader on node 2
- AdaptaScan Bar Code Reader on node 3

When configuring a DH-485 network with AdaptaScan Readers, the nodes must be in the following order:

- SLC on node 1
- AdaptaScan Readers immediately follow SLC (node 2, node 3,...)
- Other network devices (e.g., DTAM Plus) follow the AdaptaScan Readers

Avoid node gaps to prevent the AdaptaScan Reader from Soliciting of Successor (SOS). This will maximize bar code throughput as it is sent to the SLC. The priority should be on processing bar code data not on finding node gaps.

Hardware Requirements

The hardware items required for this application are:

- 2755-SN3, -SN5 or -SN8 AdaptaScan Bar Code Reader
- 2755-NB40 or -NB41 Wiring Base
- 2755-PW46 or -PW47 Power Supply
- 2755-NC43 or -NC48 Configuration Cable
- 1747-L532 or -L54x SLC processor
- 1746 Chassis and 24V dc Power Supply
- 1747-CP3 RS-232 Programmer Cable
- 1747-AIC Isolated Link Coupler or 1761-NET-AIC Advanced Interface Converter
- 1747-PIC RS-232/DH-485 Converter
- Computer running Windows 3.1 (or later) or Windows 95
- 9-to-25 Pin Adapter (for computer with a 25-pin COM port)

Software Requirements

The software requirements for this application are:

- 2755-ASN AdaptaScan Offline Programming Software
- 9323-PA2x SLC 500 Advanced Programming Software (The original ICOM SLC software is not compatible with this AdaptaScan network configuration.)

Related Publications

Related publications include:

Publication	Description
2755-837	AdaptaScan Bar Code Readers User Manual
2755-838	AdaptaScan Software User Manual

In addition, you may want to refer to the SLC 500 Hardware and Software User Manuals.

Connecting a Power Supply to the Reader

The following illustration shows how to connect a 2755-PW46 or -PW47 power supply to a single bar code reader. The power supply connection applies to both readers.

Use a shielded cable (Belden 9316 recommended) to make the connections. Connect the shield to the ground screw on the reader's wiring base.

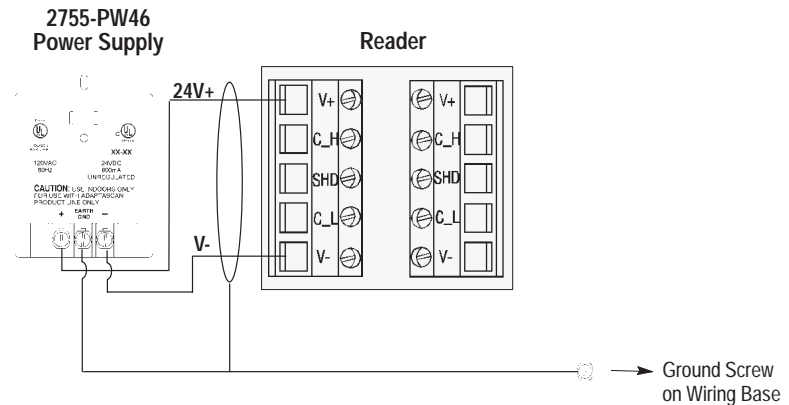

Connecting to the DH-485 Network

The wiring base of the AdaptaScan Reader has an RS-485/RS-422 terminal block for point-to-point or network connections.

This section shows three connection options:

- Connecting readers to SLC 5/03
- Connecting readers to SLC 5/04 using two 1747-AIC Modules
- Connecting readers to SLC 5/04 using one 1747-AIC Module

Note: You can use the 1761-NET-AIC Advanced Interface Converter in place of the 1747-AIC Module.

Important: The DH485 network cable requires proper shielding, grounding and termination. Refer to *Data Highway/Data Highway Plus/Data Highway DH485 Cable Installation Manual* (Publication No. 1770-6.2.2).

Connecting Readers to SLC 5/03 Controller

You must use a link coupler if the distance between the reader and the SLC is greater than 15.2 meters (50 feet). The reader can connect directly to another RS-485/RS-422 device. Point-to-point and network connections are the same.

The end devices on the DH-485 network must be terminated. The wiring base of the AdaptaScan Reader provides a termination switch.

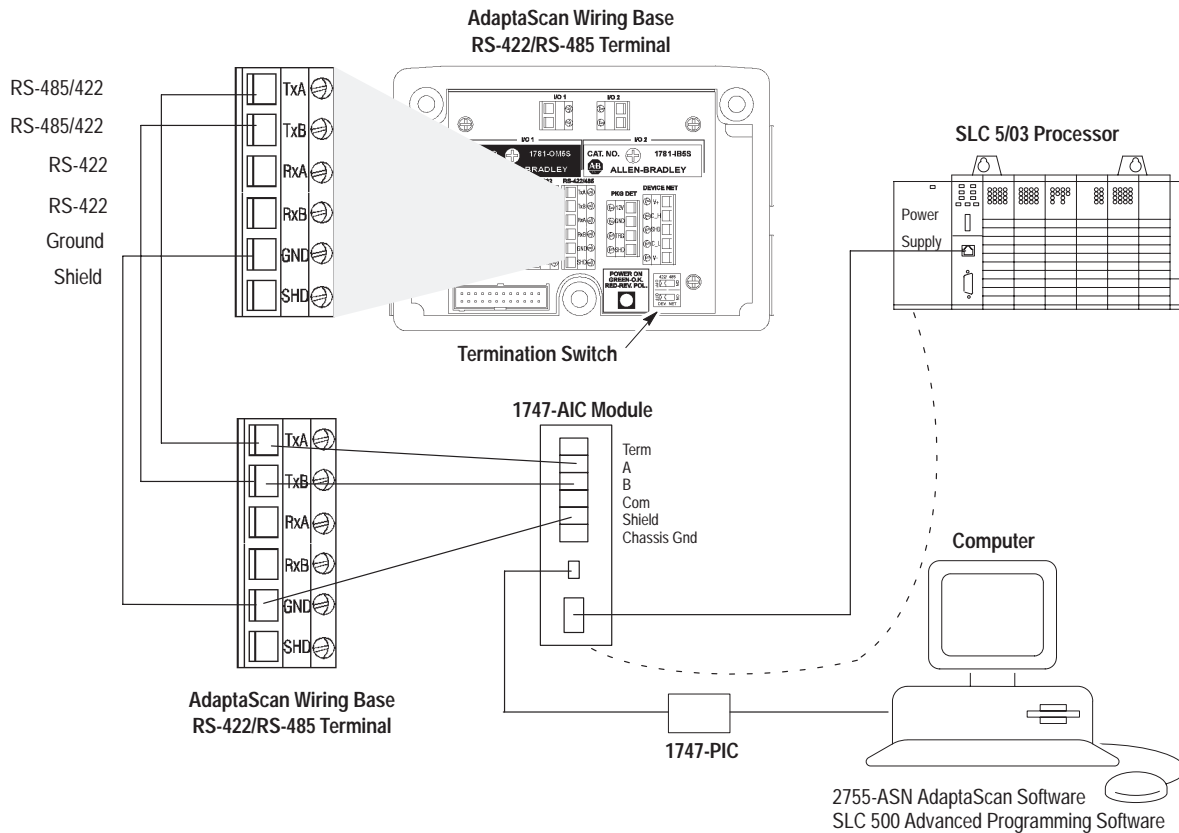

Connecting Readers to SLC 5/04 Controller – 2 AIC Modules

The SLC 5/04 controller requires two 1747-PIC converters and a power supply to connect to the second 1747-AIC module.

The end devices on a DH-485 network must be terminated. The wiring base of the AdaptaScan Reader provides a termination switch.

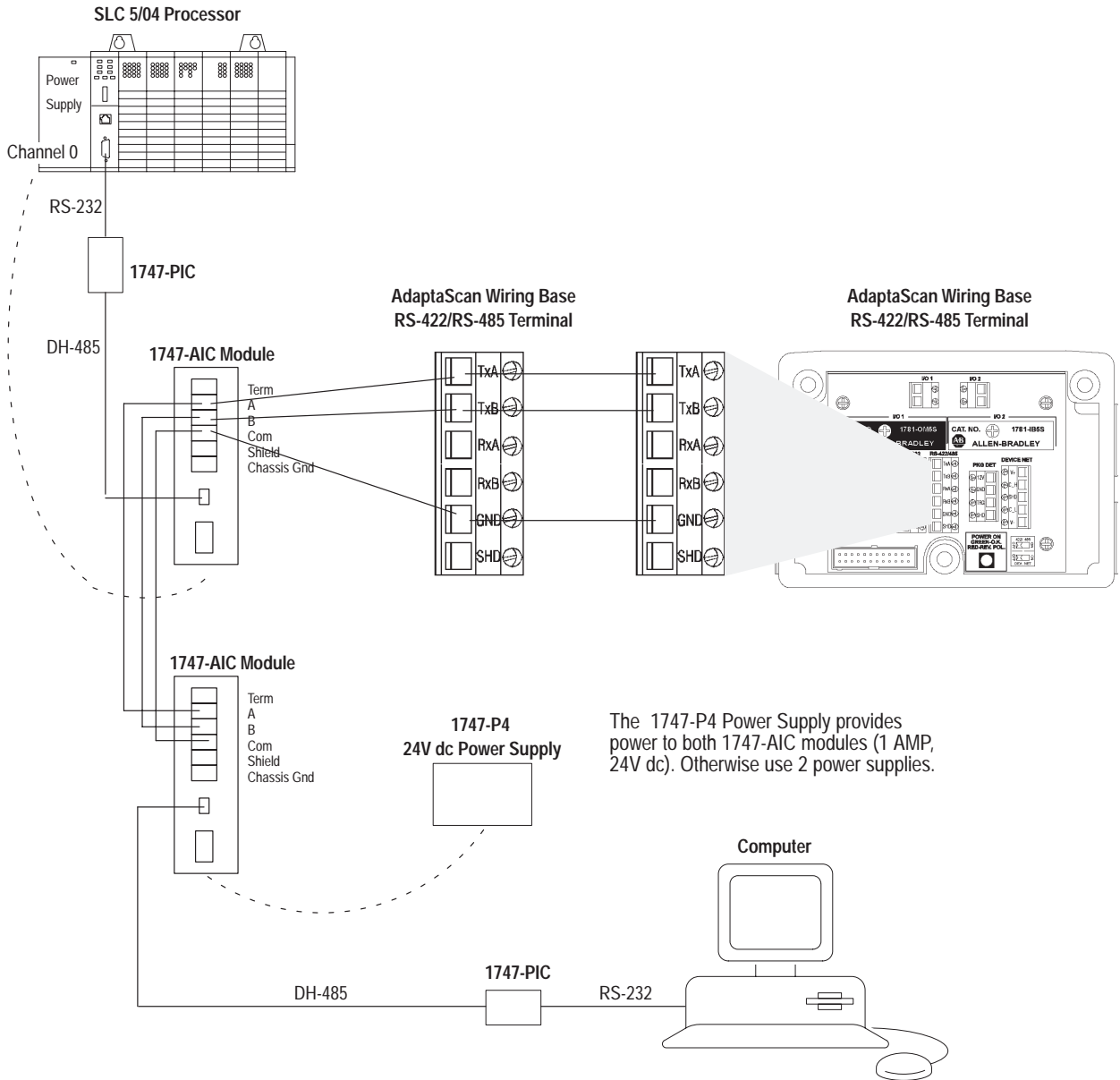

Connecting Readers to SLC 5/04 Controller – 1 AIC Module

The SLC 5/04 controller requires two 1747-PIC converters. However, you can use an RJ48 Y adapter (8-wire LAN phone jack plug) to connect the two 1747-PIC modules. The RJ48 Y adapter is a modular adapter for 4-pair cable which parallels two 4-pair jacks and one 4-pair modular plug. This adapter eliminates the second 1747-AIC module shown on the previous page.

The end devices on a DH-485 network must be terminated. The wiring base of the AdaptaScan Reader provides a termination switch.

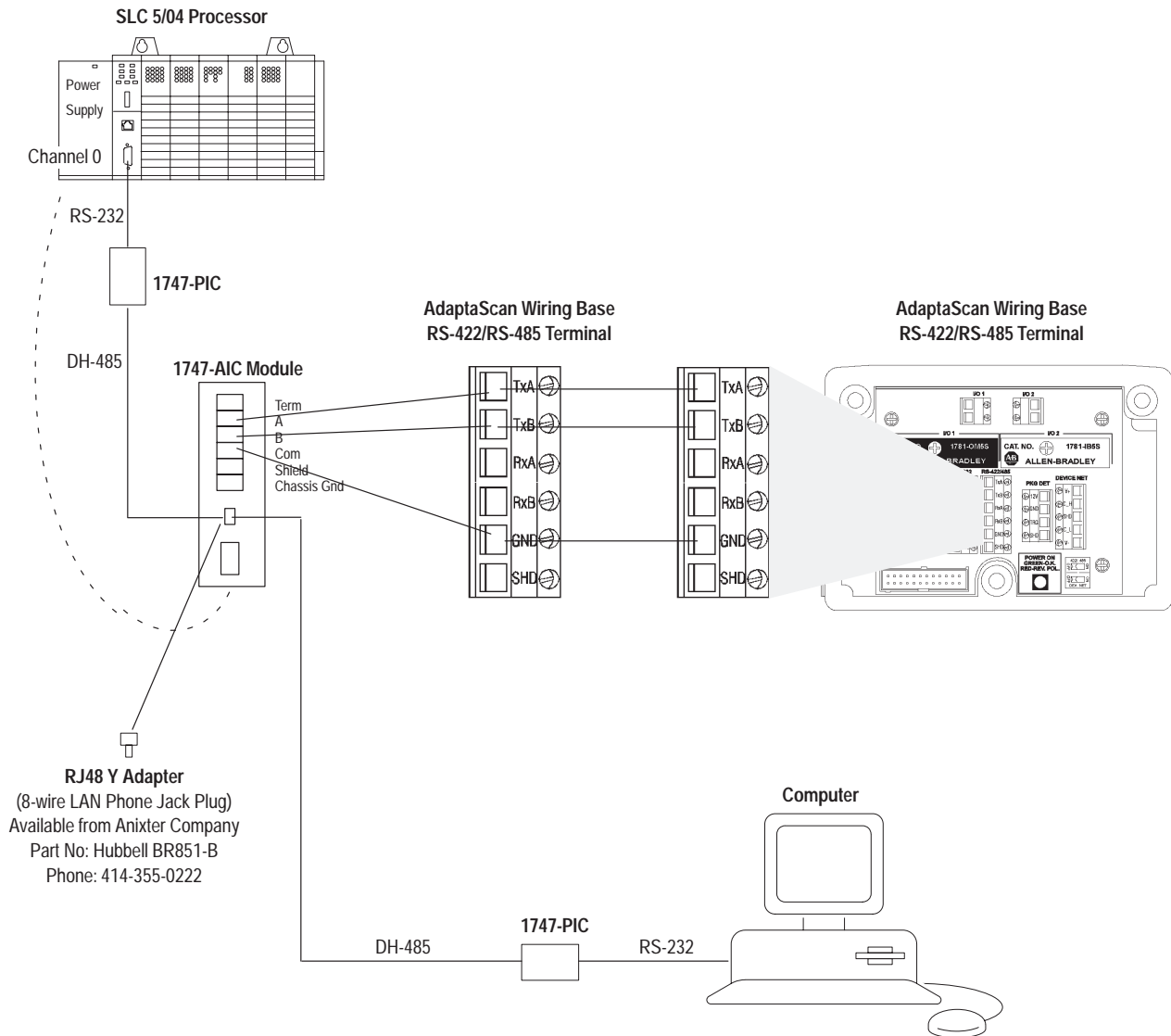

Configuring the SLC Controller

This section describes how to configure the SLC 5/04, which is different than the 5/03.

- Using APS and an RS-232 connection, establish an online connection the Channel 0 port of the SLC 5/04.
- When online, change to DH485 protocol and do a WHO ACTIVE to view the nodes on the network.

For complete details on configuring the SLC 5/04 or 5/03 processors, refer to the Advanced Programming Software manuals.

SLC 5/04 Configuration

1. Establish communication with the Channel 0 port of the SLC 5/04 using the 1747-CP3/A RS-232 cable.

```
Default
On line configuration
DF1 Full
F7 1200
Enter (twice)
On line (in RS-232)
```

2. Verify that you are online in "REM RUN".

```
Change configuration driver F2 - PIC
Baud Rate 19,200
Max Node 3
F7 Utility
F5 Channel 0 (Master Mode)
Power down and up
```

Configuring Bar Code Reader 1

This section shows how to configure one the AdaptaScan Bar Code Readers using the AdaptaScan Software (Catalog No. 2755-ASN).

The procedures in this section show how to:

- define the DeviceNet node address of the AdaptaScan Reader
- configure a bar code label and symbol
- configure the scanner
- configure the decoder trigger
- configure the serial port
- configure the format of messages and the message destination

The steps may vary for some procedures because of the different requirements of applications. For example, the bar code labels may vary from one application to the next.

Create a New Project

Create a new project named DH-485 Master Mode for the AdaptaScan Bar Code Readers.

1. Choose New from the Project menu to create a new project.
2. Click the New button to add a bar code reader (Bar Code Reader 1) to the project.

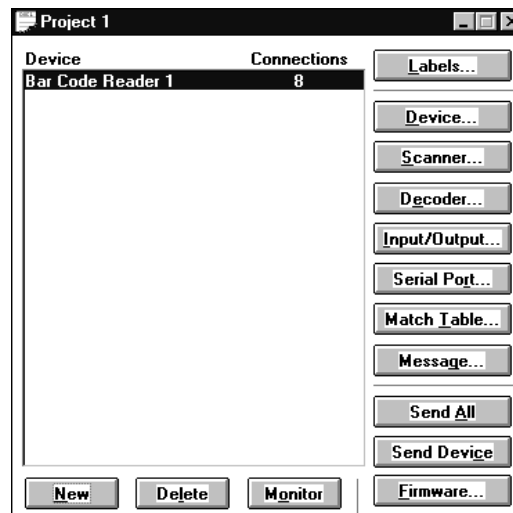

- Choose Edit from the Project menu to rename the project **DH-485 Master Mode**.



- Click Save to save the project under the new name and then Close to return to the Project dialog.

Define the Bar Code Label

- Click the Labels button to open the Bar Code Labels dialog.
- Click the New button to define a label.

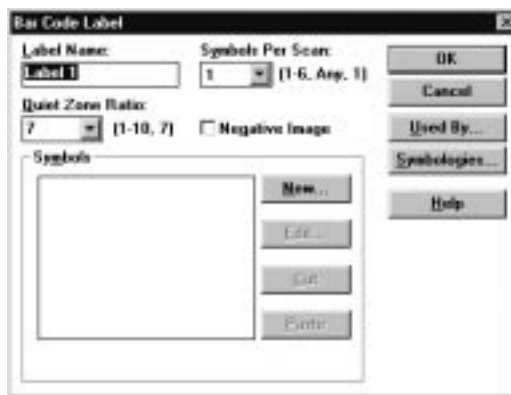

- Click the New button to define a symbol for the label.

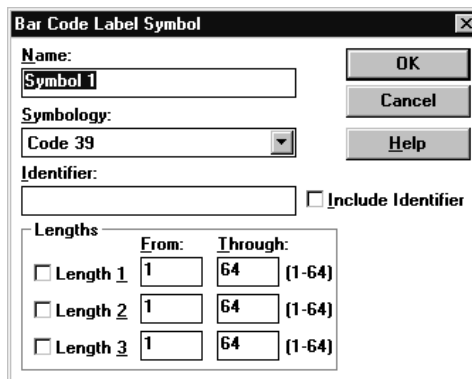

- Select a symbology and any other parameters (Identifier, Lengths) required by your application.
- Click OK until you return to the Bar Code Labels dialog.
- Click Save and then Close to return to the main Project dialog.

Define the DeviceNet Address

1. Click the Device button on the Project dialog.



2. Set the DeviceNet address to 1.

Note: The DeviceNet address is not always the same as the DH-485 node address. A DH-485 node address is assigned later.

3. Connect the 2755-NC43 or -NC48 Configuration Cable to the reader.
4. Click the Apply button.
5. Click Save and Close to return to the Project dialog.

Configure the Scanner

1. Click the Scanner button on the Project dialog to open the Scanner dialog.



2. Configure the scan pattern and use the Focus procedure for optimum scanner focus.
3. Click the Close button and return to the Project dialog.

Configure the Decoder Trigger

This application uses a Timer to trigger the reader's decoder. The Timer is typically used during application setup. Refer to Publication No. 2755-837 for other input sources that trigger the decoder.

1. Click the Decoder button from the main Project dialog.
2. Under Triggered By, select **Timer** from the Input list.



3. Click the Save button.
4. Click the Close button and return to the main Project dialog.

Configure the Serial Port

1. Click the Serial Port button from the Project dialog.

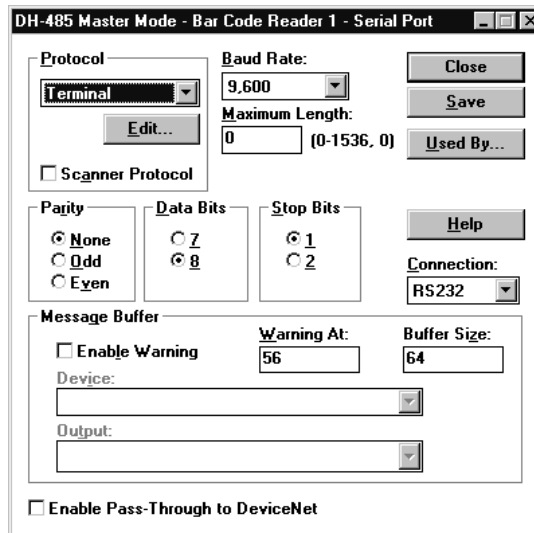

2. Configure the serial port as follows:
 - From the Protocol list box, select **DH-485**
 - From the Baud Rate list box, select **19,200**
 - From the Connection list box, select **RS485**

The configuration must match the host configuration.

- Click the Edit button under Protocol to edit the DH-485 parameters.

The screenshot shows the DH-485 configuration dialog box. The 'Node' dropdown is set to 2, 'Maximum Node' is set to 31, and 'Destination Node' is set to 0. The 'N9:Offset' is set to 100. The 'Master/Slave' section has 'Master' selected, and 'PCCC Enabled' is checked. The 'OK', 'Cancel', and 'Help' buttons are visible on the right.

Edit the parameters as follows:

- From the Node list box, select **2**
This is the node address of the reader on the network.
 - From the Maximum Node list box, select **3**
This is the number of nodes on the network.
 - Under Destination, select **1** from the Node list box
This is the SLC node where the decoded bar codes are sent.
 - In the N9:Offset box, type **100** which is the default.
This is the SLC destination address where the decoded bar codes are sent. N9: is reserved for communications. Bar code data is sent as an ASCII string to the SLC file.
- Click OK to return to the Serial Port dialog.
 - Click Save and then Close to return to the Project dialog.

Create a Message

Data sent from the AdaptaScan Reader to the SLC processor uses messages.

1. Click the Message button from the main Project dialog.

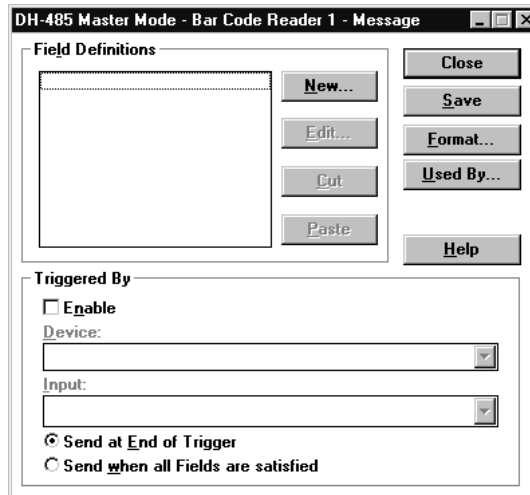

2. Under Triggered By, check the Enable check box.
3. Under Device, select **Bar Code Reader 1**.
4. Under Input, select [**Decoder**].
5. Click the New button to create a message field.



6. Under Symbol Source, select Bar Code Reader 1.
7. Under Bar Code Labels & Symbols, select **Symbol 1**.
8. Check (enable) the Match Exactly check box.

- Click the Edit button to open the Message Field Edit dialog.

- Under Replacement Strings, type **NO READ 1** in the Fail: box.
Bar code data is sent to the SLC controller on a valid read. The Fail string sends “NO READ 1” to the controller when a no read occurs on Bar Code Reader 1.
- Click OK to return to the Message Field dialog.
- Click OK again to return to the Message dialog.

Define the Message Format

- Click the Format button from the Message dialog.

- In the Trailer text box, type `\r\n` (for CR, LF).
- Under Message Destination, select **Serial Port** (This is the serial port of Bar Code Reader 1).
- Click OK to return to the Message dialog.
- Click Save and then Close to return to the Project dialog.

Sending the Configuration to Reader 1

From the main Project dialog, click the Send Device button to send the configuration to Bar Code Reader 1.

Use the Monitor dialog to verify the decoding of bar code labels.

Configuring Bar Code Reader 2

This section shows how to configure Bar Code Reader 2 which is node 3 on the DH-485 network.

Add a Second Bar Code Reader to the Project

From the Project dialog, click the New button to add Bar Code Reader 2 to the project.



Define the DeviceNet Address

1. Click the Device button on the Project dialog.



2. Set the DeviceNet address to **2** for the configuration download.

Note: The DeviceNet address is not always the same as the DH-485 node address. A DH-485 node address is assigned later.

3. Connect the 2755-NC43 or -NC48 Configuration Cable.
4. Click the Apply button.
5. Click the Close button and return to the Project dialog.

Define the Bar Code Label

1. Click the Labels button to open the Bar Code Labels dialog.
2. Click the New button to define a label.

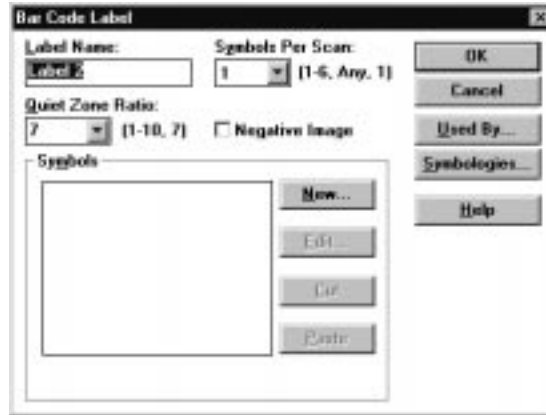

3. Click the New button to define a symbol for the label.

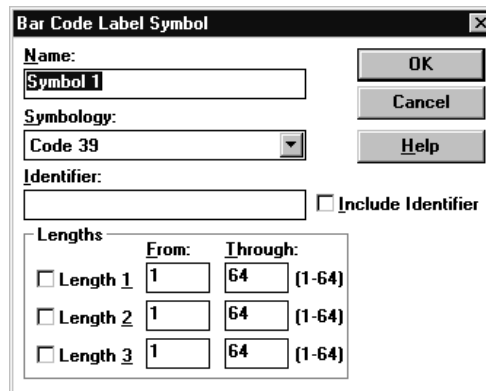

4. Select a symbology and any other parameters (Identifier, Lengths) required by your application.
5. Click OK until you return to the Bar Code Labels dialog.
6. Click Save and then Close to return to the main Project dialog.

Configure the Scanner

1. Click the Scanner button on the Project dialog to open the Scanner dialog.



2. Configure the scan pattern and use the Focus procedure for optimum scanner focus.
3. Click the Close button and return to the Project dialog.

Configure the Decoder Trigger

This application uses a Timer to trigger the reader's decoder. The Timer is typically used during application setup. Refer to Publication No. 2755-837 for other input sources that trigger the decoder.

1. Click the Decoder button from the main Project dialog.



2. Under Triggered By, select **Timer** from the Input list.
3. Click the Save button.
4. Click the Close button and return to the Project dialog.

Configure the Serial Port

1. Click the Serial Port button from the Project dialog.



2. Configure the serial port as follows:
 - From the Protocol list box, select **DH-485**
 - From the Baud Rate list box, select **19,200**
 - From the Connection list box, select **RS485**
3. Click the Edit button under Protocol to edit the DH-485 parameters.



Edit the parameters as follows:

- From the Node list box, select **3**.
This is the node address of the reader on the network.
 - From the Maximum Node list box, select **3**.
This is the number of nodes on the network.
 - Under Destination, select **1** from the Node list box.
This is the SLC node where the decoded bar codes are sent.
 - In the N9:Offset box, type **110**.
This is the SLC destination address where the decoded bar codes (ASCII string) are sent. N9: is reserved for communications.
4. Click OK to return to the Serial Port dialog.
 5. Click Save and then Close to return to the main Project dialog.

Create a Message

1. Click the Message button from the Project dialog.



2. Under Triggered By, check the Enable box.
3. Under Device, select **Bar Code Reader 1**.
4. Under Input, select **[Decoder]**.
5. Click the New button to create a message field.

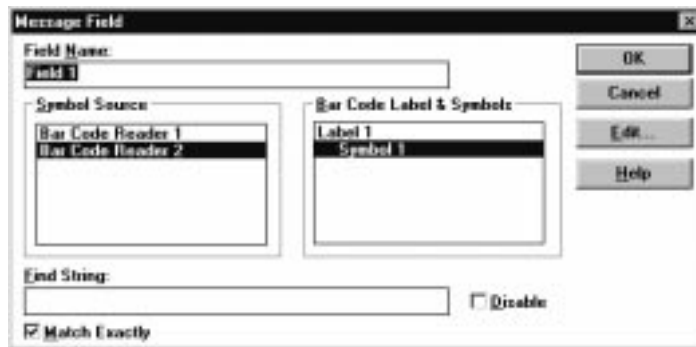

6. Under Symbol Source, select **Bar Code Reader 2**.
7. Under Bar Code Labels & Symbols, select **Symbol 1**.
8. Check (enable) the Match Exactly check box.

Match exactly specifies that ASCII characters are matched instead of a metacharacter rule.

- Click the Edit button to open the Message Field Edit dialog.



- Under Replacement Strings, type **NO READ 2** in the Fail: box.
Bar code data is sent to controller on a valid read; the Fail string sends the message NO READ 2 when a no read occurs from Bar Code Reader 2.
- Click OK to return to the Message Field dialog.
- Click OK again to return to the Message dialog.

Define the Message Format

- Click the Format button from the Message dialog.

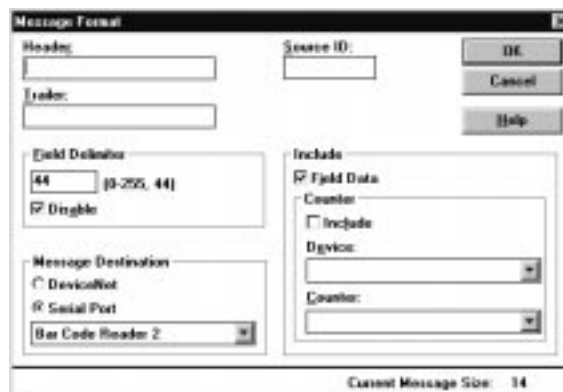

- In the Trailer text box, type **\r\n** (for CRLF).
- Under Message Destination, select **Serial Port** (This is the serial port of Bar Code Reader 2).
- Click OK to return to the Message dialog.
- Click Save and then Close to return to the Project dialog.

Sending the Configuration to Reader 2

From the main Project dialog, click the Send Device button to send the configuration to Bar Code Reader 2.

Use the Monitor dialog to verify the decoding of bar code labels.

Running the Application

After downloading the configurations to both AdaptaScan Readers, establish an online connection with the SLC processor. Use the SLC data monitor screen to view the bar code data (in ASCII format) in the N9 file.

Note: Data is not sent to the ASCII (ST) file.

Communicating with a PLC-5[®] over an RS-232 or RS-422 Link

Overview

The New Generation PLC-5 processors from Allen–Bradley have a user port that can be used to interface a single point AdaptaScan Bar Code Reader using either RS-232 or RS-422 communication.

This document includes cable diagrams and configuration information for the AdaptaScan readers. It also includes an example PLC-5 program which is needed to establish communication through Channel 0 on the new PLC-5 platform.

Hardware Requirements

The hardware items required for this application are:

- 2755-SN3, -SN5, or -SN8 AdaptaScan Bar Code Reader
- 2755-NB40 or -NB41 Wiring Base
- 2755-PW46 or -PW47 Power Supply
- 2755-NC43 or -NC48 Configuration Cable
- 1785 PLC-5 processor
- 1771 chassis
- 1771 power supply
- appropriate cables to program the PLC-5 and to configure the AdaptaScan Bar Code Reader
- 1784-KT or equivalent card installed in your personal computer to enable you to program the PLC-5

Software Requirements

The software requirements for this application are:

- 2755-ASN AdaptaScan Offline Programming Software
- PLC-5 programming software

Related Publications

Publications you might want to refer to include:

Publication	Description
2755-837	AdaptaScan Bar Code Readers User Manual
2755-838	AdaptaScan Software User Manual

In addition, you may want to refer to the PLC-5 Hardware and Software User Manuals.

Connecting the PLC-5 Processor to the Reader

For this application the PLC-5 occupies the first slot in a 1771 chassis. Power is supplied externally or from an internal power supply installed in any acceptable slot in the 1771 chassis.

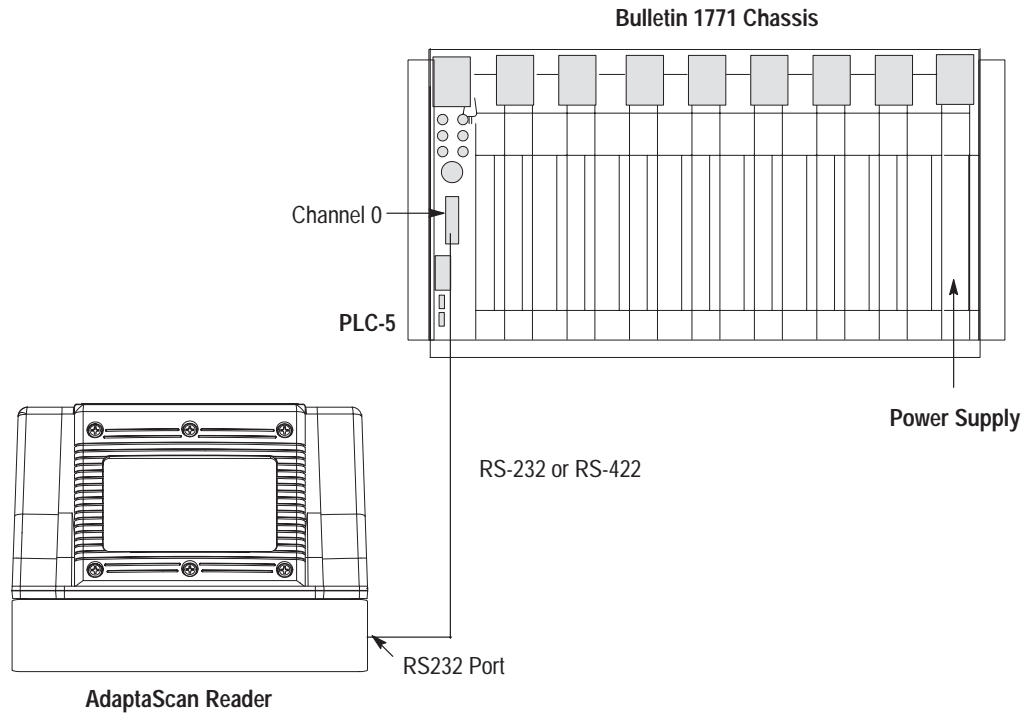

Cabling

RS-232 cabling must be constructed to connect the RS232 port of the AdaptaScan reader to User Port 0 on the PLC-5. Refer to this cabling diagram.

PLC-5/30, /40, /60 Channel 0	AdaptaScan RS232 Terminal Strip
PIN	PIN
2	Rx
3	Tx
7	GND

For RS-422 installations, a special pinout cable must be constructed.

PLC-5/30, /40, /60 Channel 0	AdaptaScan Terminal Strip RS-422/485
PIN	PIN
2 TxD+ _____	RxA-
14 TxD- _____	RxB+
3 RxD+ _____	TxA-
16 RxD- _____	TxB+

Note: Maximum run length 200 feet

Configuring the PLC Processor

The screens in this section show the software configuration for the PLC-5 using the programming software.

- Set the PLC-5 Channel 0 to **USER** in the Channel Overview screen.

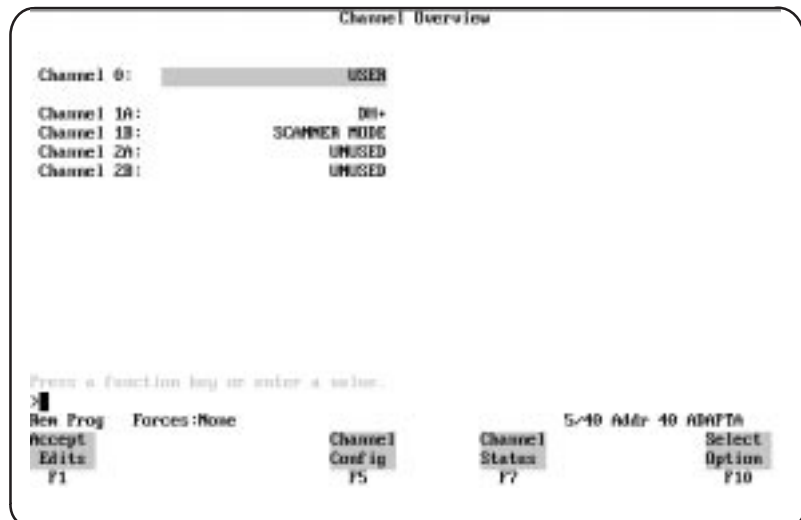

- Configure Channel 0 in the User Mode Channel 0 Configuration screen.



Note: Termination 2 is set for \0xa or Line Feed [LF], and Termination 1 is set for \0xd or Carriage Return [CR]. These terminators, along with the ARL instruction in the PLC-5, allow the User port to read in one message at a time with [CR][LF] terminators.

PLC-5 Ladder Logic Program

The sample ladder logic below instructs the PLC-5 to:

- Read one string of ASCII data terminated with a [CR][LF].

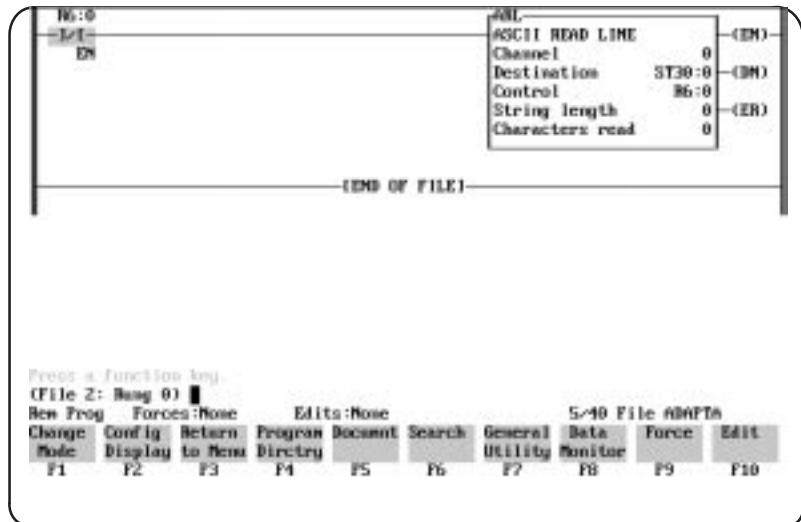

Refer to your PLC-5 user manual for detailed information on using the PLC-5 programming software including the ASCII instructions.

Configuring the Reader

This section shows how to configure the AdaptaScan Bar Code Reader using the AdaptaScan Software (Catalog No. 2755-ASN).

The procedures in this section show how to:

- configure a DeviceNet address
- configure a bar code label and symbol
- configure the scanner
- configure the decoder trigger
- configure the serial port
- configure the content and format of messages

These procedures provide general guidelines for setting up an application. You may need to modify the configuration for your application needs.

Create a New Project

Create a new project named PLC for one AdaptaScan Bar Code Reader (Bar Code Reader 1).

1. Choose New from the Project menu to create a new project.
2. Click the New button to add a bar code reader (Bar Code Reader 1) to the project.

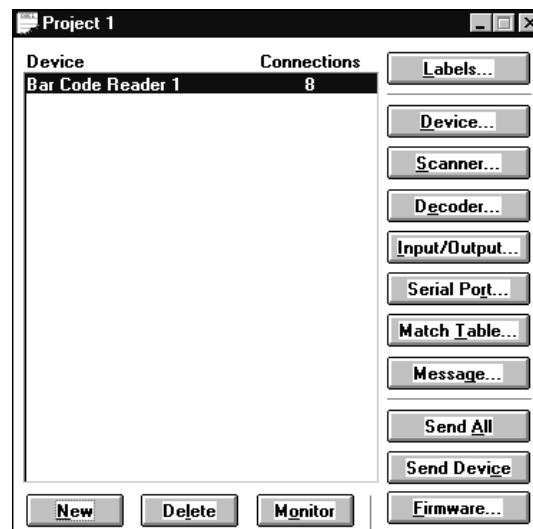

3. Choose Edit from the Project menu to rename the project **PLC**.

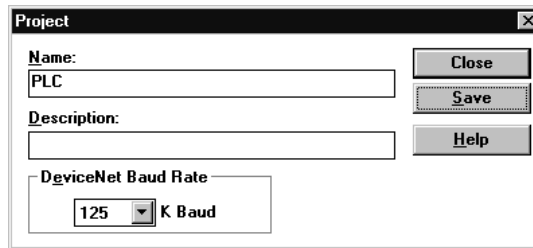

4. Click Save to save the project under the new name and then Close to return to the Project dialog.

Define the Bar Code Label

1. Click the Labels button to open the Bar Code Labels dialog.
2. Click the New button to define a label.

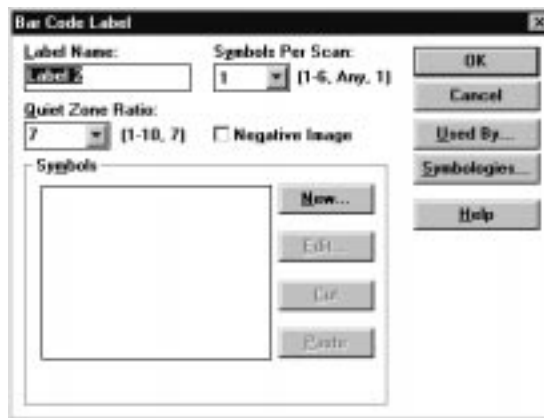

3. Click the New button to define a symbol for the label.

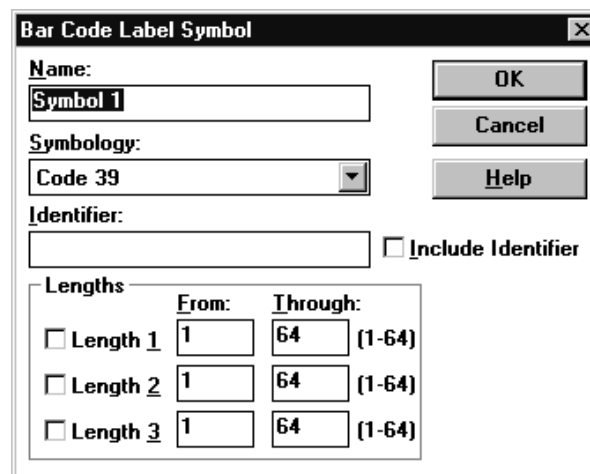

4. Select a symbology and any other parameters (Identifier, Lengths) required by your application.

5. Click OK until you return to the Bar Code Labels dialog.
6. Click Save and then Close to return to the Project dialog.

Define the DeviceNet Address

1. Click the Device button on the Project dialog.

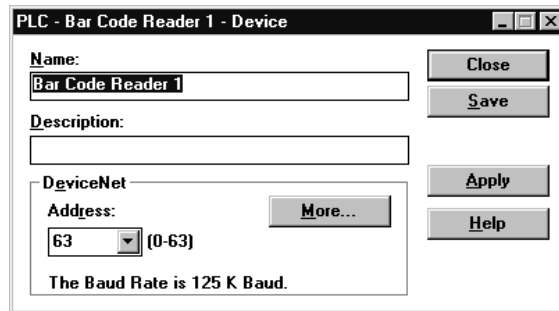

2. Set the DeviceNet address.
3. Connect the 2755-NC43 or -NC48 Configuration Cable to the reader.
4. Click the Apply button.
5. Click Save and Close to return to the Project dialog.

Configure the Scanner

1. Click the Scanner button on the Project dialog to open the Scanner dialog.

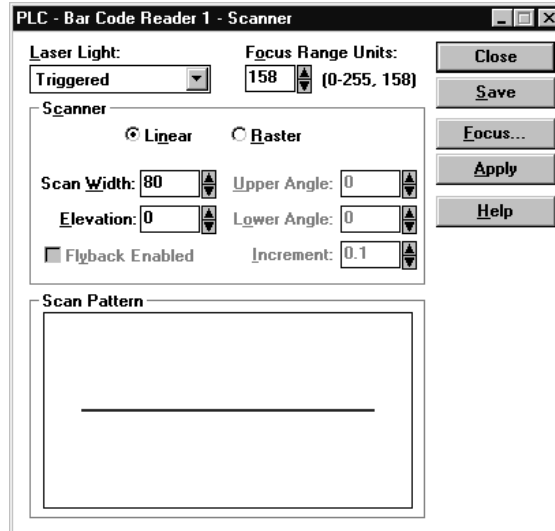

2. Configure the scan pattern and use the Focus procedure for optimum scanner focus.
3. Click the Close button and return to the Project dialog.

Configure the Decoder Trigger

This application uses a Timer to trigger the reader's decoder. The Timer is typically used during application setup. Refer to Publication No. 2755-837 for other input sources that trigger the decoder.

1. Click the Decoder button from the main Project dialog.
2. Under Triggered By, select **Timer** from the Input list.

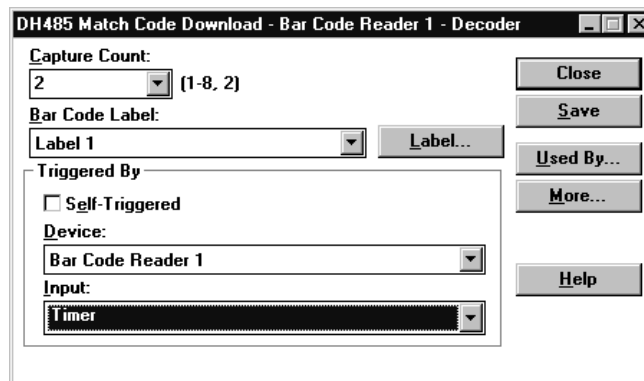

3. Click Save and then Close to return to the main Project dialog.

Configure the Serial Port

1. Click the Serial Port button on the main Project dialog.

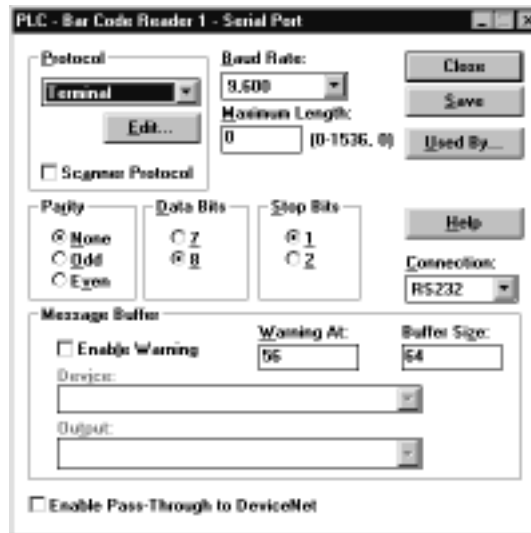

2. Verify that **Terminal** is selected in the Protocol list box. Also verify that the settings match the Channel 0 User settings. In this example, RS232 is selected in the Connection list box.
3. Click the Edit button to open Terminal dialog.
4. Set the attributes as necessary.

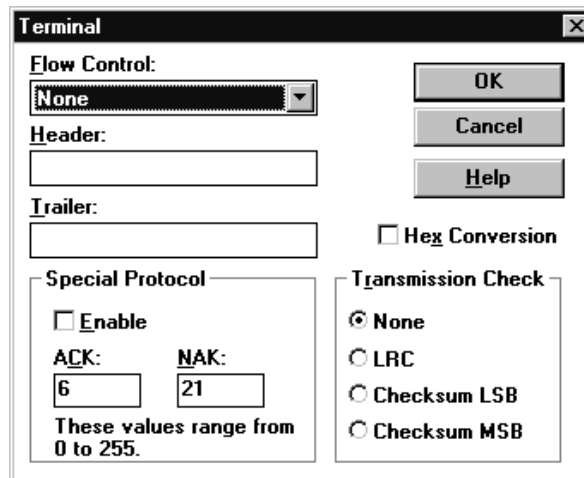

5. Click OK to exit the dialog.
6. Click the Save and then the Close button on the Serial Port dialog to return to the Project dialog.

Create a Message

The Message dialogs define the format and content of message data sent to the host by the reader when bar codes are decoded.

1. Click the Message button from the main Project dialog.
2. Under Triggered By, check the Enable check box.

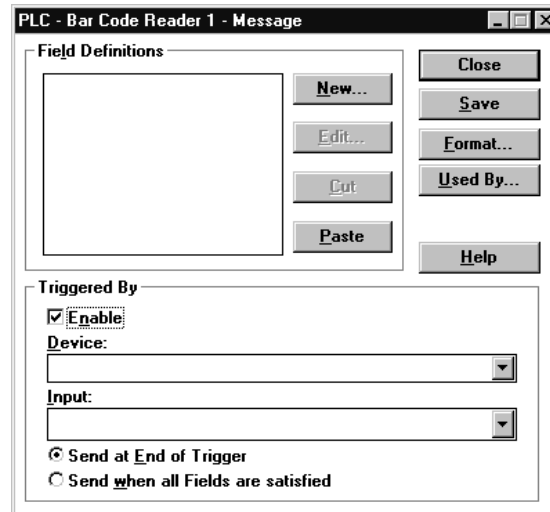

3. Under Device, select **Bar Code Reader 1**.
4. Under Input, select **[Decoder]**.
5. Click the New button to define a message field.

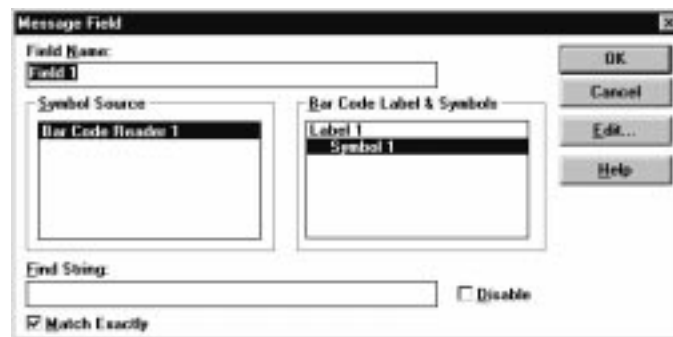

6. Under Symbol Source, select **Bar Code Reader 1**.
7. Under Bar Code Labels & Symbols, select **Symbol 1**.
8. Check (enable) the Match Exactly check box.

- Click the Edit button to open the Message Field Edit dialog.

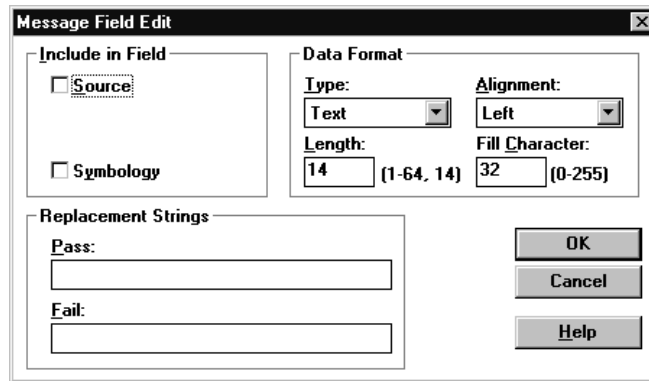

- Under Replacement Strings, type **no read** in the Fail: field.
Bar code data is sent to the controller on a valid read. The Fail string sends the characters “no read” when a no read occurs.
- Click OK to return to the Message Field dialog.
- Click OK to return to the Message dialog.

Define the Message Format

The format of the message is defined below.

- Click the Format button from the Message dialog.
- In the Trailer field, type `\r\n` (Carriage Return, Line Feed).
- Under Message Destination, select **Serial Port**.



- Click OK to return to the Message dialog.
- Click the Save button and then the Close button to return to the Project dialog.

Sending the Configuration to the Reader

From the main Project dialog, click the Send Device button to download the configuration to the bar code reader.

Use the Monitor dialog to verify the decoding of bar code labels.

Running the Application

If the AdaptaScan Bar Code Reader is configured correctly and the PLC-5 program is entered as shown in this application example, bar code data or “no read” will be sent to the PLC user port.

Communicating with an SLC 5/03 Processor on a DeviceNet™ Network

Overview

This application describes how to connect and configure an AdaptaScan Bar Code Reader to communicate with an SLC 5/03 processor over a DeviceNet network in a master/slave mode. A 4 character Interleaved 2 of 5 bar code symbol is used in this application.

The DeviceNet network has the following nodes:

- AdaptaScan Bar Code Reader on node 3
- 1747-SDN DeviceNet Scanner on node 1
- Computer running DeviceNet Manager Software on node 62.

The DeviceNet terminal block in the reader's wiring base connects the AdaptaScan Reader to the DeviceNet network. The wiring base has two DeviceNet terminal blocks; one for upstream connection and one for downstream connection.

Hardware Requirements

The hardware items required for this application are:

- 2755-SN3, -SN5 or -SN8 AdaptaScan Bar Code Reader
- 2755-NB40 or -NB41 Wiring Base
- 2755-PW46 or -PW47 Power Supply (if not power by DeviceNet)
- 2755-NC43 or -NC48 Configuration Cable
- 1747-SDN Scanner Module (v2.05 firmware or later)
- 1770-KFD DeviceNet RS-232 Interface Box
- RS-232 cable for the RS-232 Interface Box
- DeviceNet trunk cable
- 1746 Chassis and 24V dc Power Supply
- SLC 5/03 processor
- Computer running Windows 3.1 (or later) or Windows 95
- 9-to-25 Pin Adapter (for Computer with 25-pin COM port)

Software Requirements

The software requirements for this application are:

- 2755-ASN AdaptaScan Offline Programming Software (v8.0 or later)
- SLC Advanced Programming Software
- 1787-MGR DeviceNet Manager Software (v3.0 or later)

Related Publications

Related publications include:

Publication	Description
2755-837	AdaptaScan Bar Code Readers User Manual
2755-838	AdaptaScan Software User Manual
1787-6.5.3	DeviceNet Manager Software Manual
1747-6.5.2	1747-SDN DeviceNet Scanner Configuration Manual

In addition, you may want to refer to the SLC 500 Hardware and Software User Manuals.

Connecting to the DeviceNet Network

The following illustration shows the nodes of the DeviceNet master/slave network. You must terminate the first and last node in the network. Refer to the *1747-SDN DeviceNet Scanner Configuration Manual* (Publication No. 1747-6.5.2) for more information regarding user termination information.

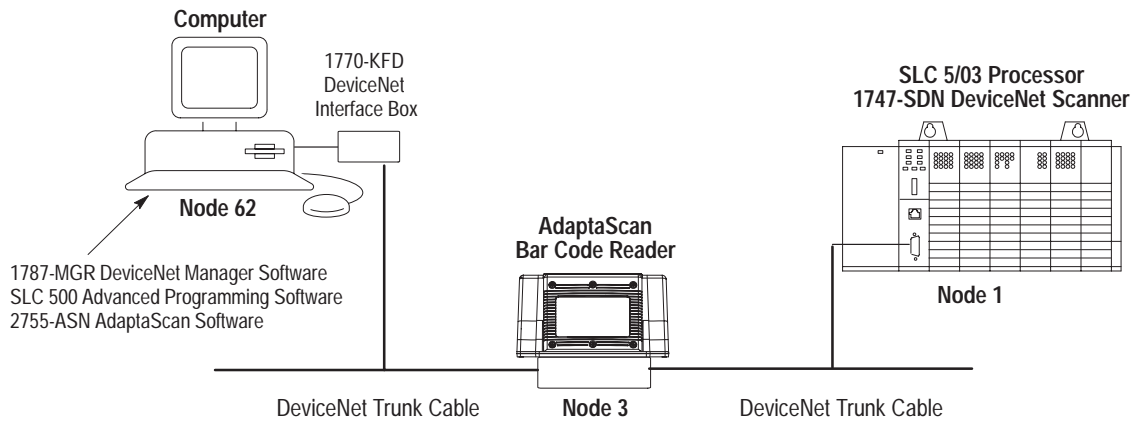

Connecting a Power Supply to the Reader

The following illustration shows how to connect a 2755-PW46 or -PW47 power supply to a single bar code reader.

Use a shielded cable (Belden 9316 recommended) to make the connections. Connect the shield to the ground screw on the reader's wiring base.

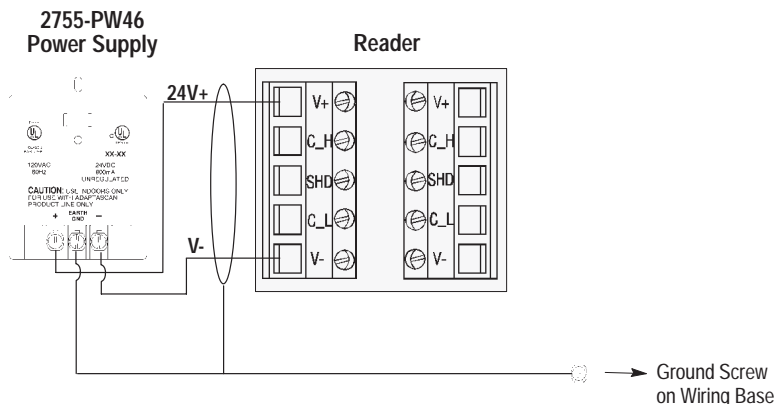

Note: Use a termination switch for DeviceNet in the wiring base for the end of the network.

SLC Ladder Logic

This section provides the SLC ladder logic program and data monitor results. The ladder logic uses:

- File N23 as the SLC interface to M1 file
- File N22 as the SLC interface to M0 file

The data table shows file N23 after the AdaptaScan Reader successfully reads and transfers data '0300' (from a 4 character, Interleaved 2 of 5 symbol) to the SLC data table.

File	Location	Description
Discrete Output O	Word 0 Bit 0	1=SDN card in run mode 0=SDN card in idle mode
N23	Word 0	Status word
	Word 1 Bit 15	'New Message Being Sent' bit from AdaptaScan Reader
N22	Word 0	Status word
	Word 1 Bit 7	'Send Message' bit to AdaptaScan Reader

Message AddressingA

Message Data is formatted the same as messages sent through the serial port. When setting up the DeviceNet scanner for addressing message data, use the following table.

Description	Word #	Byte # ^{①②}
Number of Characters (LSB)	2	2
Number of Characters (MSB)		3
First Message Character (Beginning of Message)	3	4
Other Message Characters from left to right		5 →
Last Message Character (End of Message)		3+N where N is the number of characters in the message.

^① Bytes #0 and #1 (word 1) are reserved for Discrete I/O.

^② Poll Rx Size = 4 + (# of Characters in string).

Message data is addressed and sent to other DeviceNet devices through a DeviceNet scanner (Catalog No. 1771-SDN or 1747-SDN). To configure the scanner, you will need to provide the size of the message data, the beginning byte and bit number of the message and the destination of the message data.

Message Flow Control

DeviceNet Input #8 and Output #16 control the transmission of bar code messages when using DeviceNet master-slave. Message flow control (handshaking) lets the controller know that data is available and that the reader does not send out messages faster than they can be received. Your controller logic program must transfer the message data and set the DeviceNet Input #8 (Send Next Data) for message flow control.

New Data

Is indicated by changing the state of DeviceNet Output #16 of the DeviceNet I/O. A change of state (0 to 1 or 1 to 0) indicates that a new message is being sent.

Send Next Data

Is indicated by changing the state of DeviceNet Input #8 of the DeviceNet I/O. A change of state (0 to 1 or 1 to 0) indicates that the controller is ready to receive the next message.

Flow Control Example

The following shows how DeviceNet Input #8 and Output #16 control the transmission of messages. Output #16 is changed by the reader and Input #8 is changed by the controller.

DeviceNet Scan Number	Message Data	DeviceNet Output #16	DeviceNet Input #8
1 - Poll	-		OFF (0)
1 - Response	No Message Sent	OFF (0)	
2 - Poll	-		ON (1)
2 - Response	Message 1 Sent	ON (1)	
3 - Poll	-		OFF (0)
3 - Response	Message 2 Sent	OFF (0)	

Note: The following ladder logic program is for reference only. Application specific interlocks may be necessary.

Rung 2:0

This rung enables Discrete Output bit 0 of slot 1. This will put the 1747-SDN card into run mode. Remember in order to “save to sdn” from the DeviceNet Manager Software you must disable this bit or put the processor into program mode.



Rung 2:1

This rung is toggled via the control bits sent from the AdaptaScan. Bit 15 in word 1 of N23 file is toggled when no data is being sent from adaptascan. It latches bit 7 in word 1 of N22 file to tell the adaptascan to send the next message.



Rung 2:2

This rung transfers data from the m1 file to the n23:0 file.

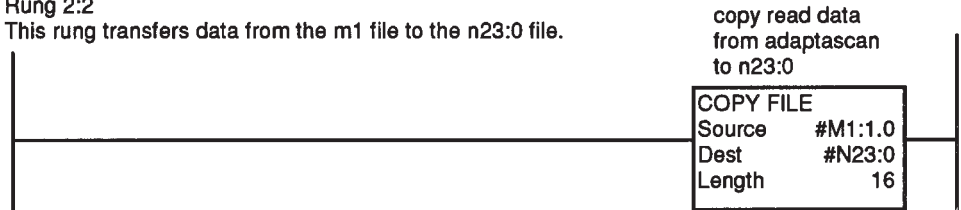

Rung 2:3

This rung transfers our control bits out to the adaptascan from n22 file

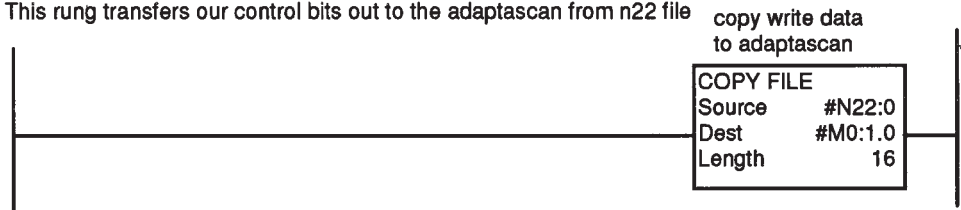

Rung 2:4

If a new message is currently being sent from the adaptascan this rung unlatches bit 7 in word 1 of N22 file. This tells the adaptascan that the sdn module is busy processing a previous message and not to send new message yet.



Rung 2:5

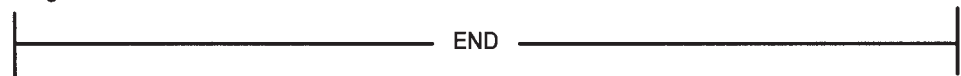

N23 Data Table File Monitor

In Data Table File N23:

- N23:1 contains the DeviceNet status bits
- Bit 15 is the control bit from the AdaptaScan Reader which toggles between 0 and 1 to indicate a ‘new message being sent’
- N23:2 is the byte count (4) of the message sent from the reader
- N23:3 is the start the of the data read 3000. Data is actually 0300. All data is byte swapped.

Note: The SLC instruction SWP can be used to swap the bar code data only.

1747-SDN to AdaptaScan Interface
Data Table

Processor File :MASTER.ACH

Data Table File N23

Address	Data (Radix = ASCII)		Processor File :MASTER.ACH				Data Table File N23					
N23:0	\00\00	\80\01	\00\04	3	0	0	0	\00\00	\00\00	\00\00	\00\00	\00\00
N23:10	\00\00	\00\00	\00\00	\00\00	\00\00	\00\00	\00\00	\00\00	\00\00	\00\00	\00\00	\00\00
N23:20	\00\00	\00\00	\00\00	\00\00	\00\00	\00\00	\00\00	\00\00	\00\00	\00\00	\00\00	\00\00
N23:30	\00\00	\00\00	\00\00	\00\00	\00\00	\00\00	\00\00	\00\00	\00\00	\00\00	\00\00	\00\00
N23:40	\00\00	\00\00	\00\00	\00\00	\00\00	\00\00	\00\00	\00\00	\00\00	\00\00	\00\00	\00\00
N23:50	\00\00	\00\00	\00\00	\00\00	\00\00	\00\00	\00\00	\00\00	\00\00	\00\00	\00\00	\00\00
N23:60	\00\00	\00\00	\00\00	\00\00	\00\00	\00\00	\00\00	\00\00	\00\00	\00\00	\00\00	\00\00
N23:70	\00\00	\00\00	\00\00	\00\00	\00\00	\00\00	\00\00	\00\00	\00\00	\00\00	\00\00	\00\00
N23:80	\00\00	\00\00	\00\00	\00\00	\00\00	\00\00	\00\00	\00\00	\00\00	\00\00	\00\00	\00\00
N23:90	\00\00	\00\00	\00\00	\00\00	\00\00	\00\00	\00\00	\00\00	\00\00	\00\00	\00\00	\00\00
N23:100	\00\00	\00\00	\00\00	\00\00	\00\00	\00\00	\00\00	\00\00	\00\00	\00\00	\00\00	\00\00
N23:110	\00\00	\00\00	\00\00	\00\00	\00\00	\00\00	\00\00	\00\00	\00\00	\00\00	\00\00	\00\00
N23:120	\00\00	\00\00	\00\00	\00\00	\00\00	\00\00	\00\00	\00\00	\00\00	\00\00	\00\00	\00\00
N23:130	\00\00	\00\00	\00\00	\00\00	\00\00	\00\00	\00\00	\00\00	\00\00	\00\00	\00\00	\00\00
N23:140	\00\00	\00\00	\00\00	\00\00	\00\00	\00\00	\00\00	\00\00	\00\00	\00\00	\00\00	\00\00
N23:150	\00\00	\00\00	\00\00	\00\00	\00\00	\00\00	\00\00	\00\00	\00\00	\00\00	\00\00	\00\00

N22 Data Table File Monitor

Below is a partial listing of the Data Table File N22. The table shows N22:1 bit 7 as the DeviceNet status bit which toggles between 0 and 1 to indicate ‘send next message’.

1747-SDN to AdaptaScan Interface

Data Table

Processor File: MASTER.ACH

Data Table File N22

Address	Data (Radix=BINARY)
N22:0	0 0 0 0 0 0 0 0 0 0 0 0 0 0 0 0
N22:1	0 0 0 0 0 0 0 0 1 0 0 0 0 0 0 0
N22:2	0 0 0 0 0 0 0 0 0 0 0 0 0 0 0 0
N22:3	0 0 0 0 0 0 0 0 0 0 0 0 0 0 0 0

Data Table File 0 Monitor

Below is a partial listing of the File 0 data table. The table shows that bit O:1/0 is set to enable run mode in the 1747-SDN Scanner (1=RUN; 0=IDLE).

1747-SDN to AdaptaScan Interface

Data Table	Processor File :MASTER.ACH	Data Table File 0
Address	Data (Radix = ASCII)	
O:1	\00101	
O:1.1	\00100	
O:1.2	\00100	
O:1.3	\00100	
O:1.4	\00100	
O:1.5	\00100	
O:1.6	\00100	
O:1.7	\00100	
O:1.8	\00100	
O:1.9	\00100	
O:1.10	\00100	
O:1.11	\00100	
O:1.12	\00100	
O:1.13	\00100	
O:1.14	\00100	
O:1.15	\00100	

Data Table File M1 Monitor

Below is a partial listing of the M1 data table.

- M1:1.1 contains the DeviceNet status bit
- M1:1.2 is the byte count (4) of a message
- M1:1.3 to M1:1.4 is data 0300 from the AdaptaScan Reader

1747-SDN to AdaptaScan Interface

Data Table	Processor File :MASTER.ACH	Data Table File M1:1
Address	Data (Radix = ASCII)	
M1:1	\00100	
M1:1.1	\80101	
M1:1.2	\00104	
M1:1.3	3 0	
M1:1.4	0 0	
M1:1.5	\00100	
M1:1.6	\00100	
M1:1.7	\00100	
M1:1.8	\00100	
M1:1.9	\00100	
M1:1.10	\00100	
M1:1.11	\00100	
M1:1.12	\00100	
M1:1.13	\00100	
M1:1.14	\00100	
M1O:1.15	\00100	

Configuring the DeviceNet Scanner

This section describes how to configure the 1747-SDN Scanner using the DeviceNet Manager software.

Before configuring the 1747-SDN Scanner, you must wire the DeviceNet network and apply DeviceNet Address 3 to the bar code reader. See page 9-16.

To configure the 1747-SDN DeviceNet Scanner:

1. Double-click the DeviceNet Manager icon.
2. Create a new project with the network name SLC503.
3. Click the Build Online button to create a DeviceNet network.
The network should have the following nodes:
 - Node 1 – 1747-SDN Scanner Module
 - Node 3 – 2755-SN5 AdaptaScan Bar Code Reader
 - Node 62 – 1787-MGR DeviceNet Manager

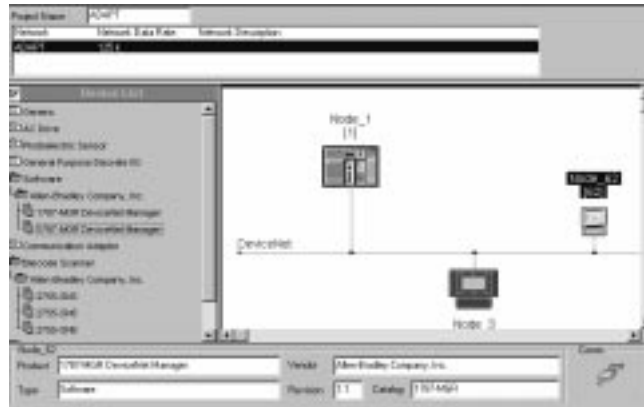

4. Double-click the 1747-SDN Scanner Module to open the 1747-SDN Module Configuration dialog.

From this dialog, you modify all configuration parameters for the 1747-SDN Scanner.

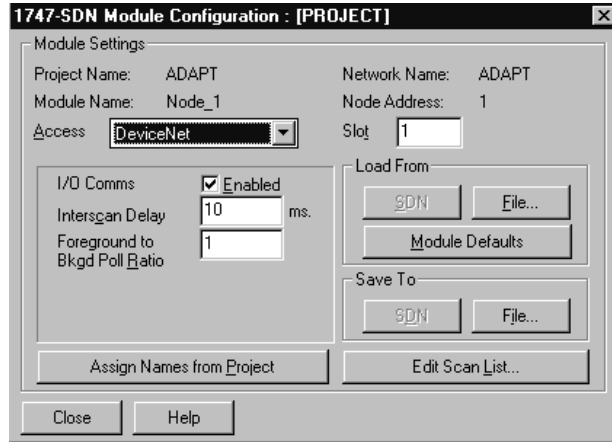

If you are using an AdaptaScan with v7.0 firmware on a network with 2 or less nodes, change the Interscan Delay parameter to 20 ms. This will allow the AdaptaScan more CPU time to process bar code data instead of responding to DeviceNet polls.

5. Click the Edit Scan List button.



Note: Version 8.0 of the AdaptaScan Offline Programming Software and firmware minimizes DeviceNet polling interruption of scanning.

6. Click the Edit I/O Parameters button.

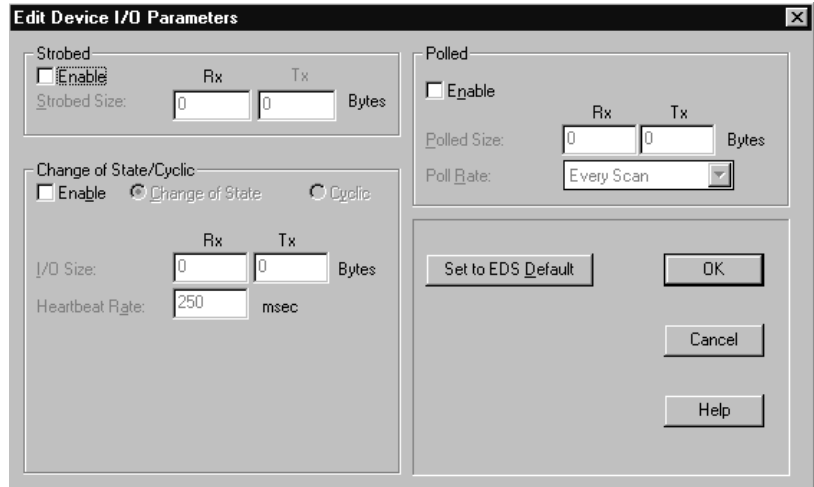

7. Click the Polled button.

8. Change the Poll Rx size to 8.

9. Change the Poll Tx size to 1.

10. Click the OK button to return to the Scan List Editor screen.

11. Click the Datable Map button.



12. Click the Data Entry button.
13. Change Map Data From to **Poll Message**.
14. Change Map Data To **M File**.
15. Change M1:1. to **1**.
16. Change No. Bits to **64**.
17. Click Apply Segment.



The dialog shows the data table map of the SLC M1 file. It displays data from the AdaptaScan Reader, which is mapped to the SLC (File N23).

Word 0 is reserved and 4 words (8 bytes) of the data table are mapped for the incoming string from the reader. Bit 15 is the 'new message being sent' bit.

18. Click the Output button.
19. Change Map Data From to **Poll Message**.
20. Change Map Data To **M File**.
21. Change M0:1. to **1**.
22. Change No. Bits to **8**.
23. Click Apply Segment button.



The dialog shows the data table map of the SLC M0 file. It displays data sent to the AdaptaScan Reader through the SDN Scanner (N22). 1 byte of data is written to the SDN Scanner.

Bit 7 of Word 1 is the 'send next message' bit.

24. Click the Close button to return to the Scanlist Editor dialog.
25. Click the Save to SDN button to download the scanlist to the 1747-SDN Scanner.

Important: Before clicking the Save to SDN button, the SDN Scanner must be in Idle Mode. Set bit O:0/1 in the SLC to 0. Another way to place the SDN Scanner in Idle Mode is to put the SLC into Program Mode.

Configuring the Reader

This section shows how to configure the AdaptaScan Bar Code Reader using the AdaptaScan Software (Catalog No. 2755-ASN).

The procedures in this section show how to:

- scan/decode 4 character, Interleaved 2 of 5 bar code symbols
- define a DeviceNet address
- configure the scanner
- trigger the decoder
- configure the format of messages and the message destination

Create a New Project

Create a new project named DeviceNet Master/Slave for one AdaptaScan Bar Code Reader (Bar Code Reader 1).

1. Choose New from the Project menu to create a new project.
2. Click the New button to add a bar code reader (Bar Code Reader 1) to the project.

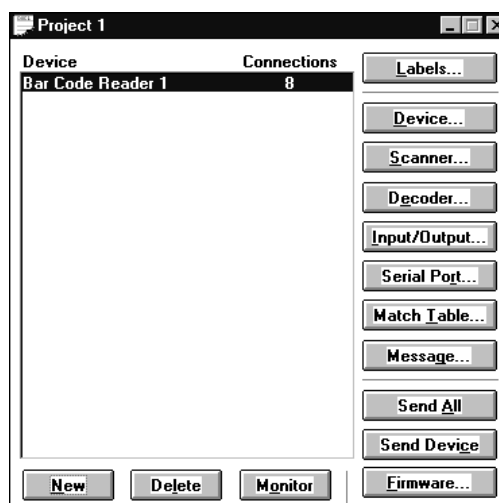

3. Choose Edit from the Project menu to rename the project **DeviceNet Master/Slave**.

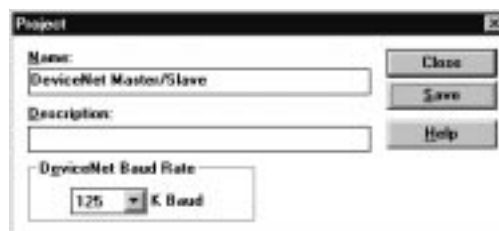

If you need to change the baud rate, proceed to the next section. If you do not need to change the baud rate, proceed to step 4.

4. Click Save to save the project under the new name and then Close to return to the Project dialog.

Change the Baud Rate

If you need to change the baud rate:

1. Click on the K Baud button and select the desired baud rate.

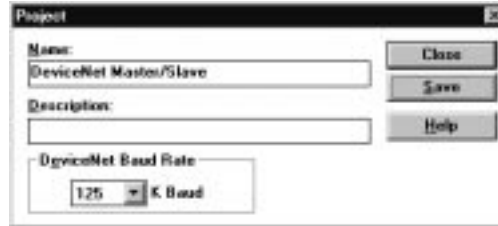

2. Click Save and Close to return to the Project dialog.
3. Click the Device button.
4. Click Apply if the desired baud rate is shown.
5. Click Save and Close to return to the Project dialog.
6. Click the Send Device button.

Define the Bar Code Label

1. Click the Labels button to open the Bar Code Labels dialog.
2. Click the New button to define a label.

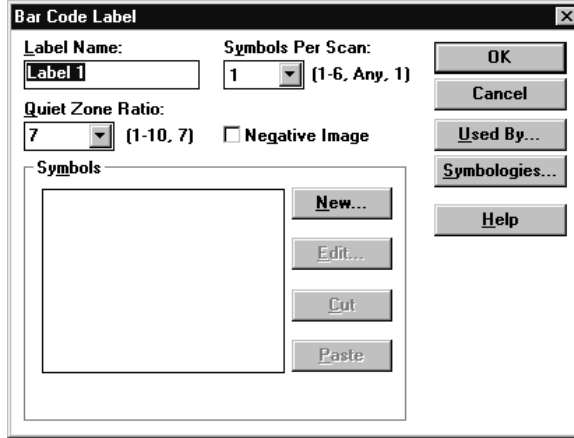

3. Click the New button to define a symbol for the label.

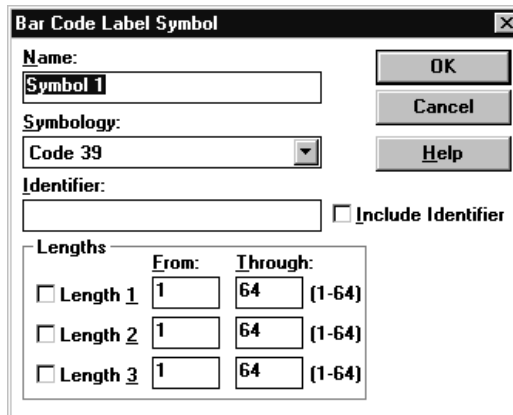

4. From the Symbology list, select **Interleaved 2 of 5**.
5. Under Lengths, select the **Length 1** check box and then type **4** in the Through box. This indicates a 4 character length for Interleaved 2 of 5 labels.
6. Click OK until you return to the Bar Code Labels dialog.
7. Click Save and then Close to return to the main Project dialog.

Define the DeviceNet Address

1. Click the Device button on the Project dialog.



2. Set the DeviceNet address to 3.
3. Connect the 2755-NC43 or -NC48 Configuration Cable to the reader.
4. Click the Apply button.
5. Click Save and Close to return to the Project dialog.

Configure the Scanner

1. Click the Scanner button on the Project dialog to open the Scanner dialog.

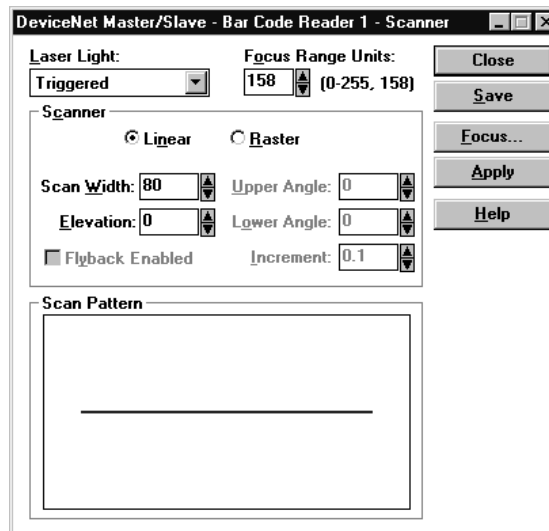

2. Configure the scan pattern and use the Focus procedure for optimum scanner focus.
3. Click the Apply button to send the scanner configuration to the AdaptaScan Bar Code Reader.
4. Click the Close button and return to the Project dialog.

Configure the Decoder Trigger

To test the application, use the Timer to trigger the reader's decoder.

1. Click the Decoder button from the main Project dialog.
2. Under Triggered By, select **Timer** from the Input list.



3. Click the Save button.
4. Click the Close button and return to the main Project dialog.

Create a Message

Defines the content of messages sent from the reader to the 1747-SDN Scanner after bar codes have been decoded.

1. Click the Message button from the main Project dialog.
2. Under Triggered By, check the Enable check box.



3. Under Device, select **Bar Code Reader 1**.
4. Under Input, select **[Decoder]**.

- Click the New button to create a message field.



- Under Symbol Source, select **Bar Code Reader 1**.
- Under Bar Code Label & Symbols, select **Symbol 1**.
- Check (enable) the Match Exactly check box.
- Click the Edit button to open the Message Field Edit dialog.



- Under Replacement Strings, type **nr** in the Fail: field.

Bar code data is sent to the 1747-SDN Scanner on a valid read; the Fail string sends the characters “nr” to the 1747-SDN when a no read occurs.

- Under Data Format, type **4** in the Length box.

Important: The Length must match the number of characters in the bar code symbol. This application uses 4 character, Interleaved 2 of 5 symbols.

- Click OK to return to the Message Field dialog.
- Click OK to return to the Message dialog.

Define the Message Format

This section defines the format and destination of messages sent from the reader.

1. Click the Format button from the Message dialog.



2. Under Message Destination, select **DeviceNet**.
3. Accept the defaults for all other parameters.
4. Click OK to return to the Message dialog.
5. Click OK again to return to the Message Field dialog.
6. Click Save and then Close to return to the main Project dialog.

Sending the Configuration to the Reader

From the main Project dialog, click the Send Device button to download the configuration to the bar code reader.

Note: If you are using Send all to download multiple reader configurations, unplug the DeviceNet scanner from the SLC processor.

Use the Monitor dialog to verify the decoding of bar code labels.

Running the Application

If the:

- AdaptaScan Reader is configured correctly,
- the 1747-SDN Scanner is configured correctly, and
- the ladder program is entered as shown in this application,

you will see bar code data or 'nr' in the SLC M1 file (N23) as bar code symbols are decoded. Remember that all data is byte swapped. If the 1747-SDN Scanner is not working properly, refer to the next section.

Troubleshooting the Module and Network

The bicolor (green/red) module status indicator (MODULE) displays module status. It indicates whether the module has power and is functioning properly.

If the Module LED is	this indicates	Take this action
Off	there is no power applied to the module.	Apply power.
Solid green	the module is operating in normal condition.	None
Flashing green	the module is not configured.	Configure the module.
Flashing red	there is invalid configuration.	Check configuration setup.
Solid red	the module has an unrecoverable fault.	Replace the module.

The DeviceNet channel has a bicolor (green/red) network status indicator (NET). The next table provides troubleshooting information about the DeviceNet channel communication link.

If the NET indicator is	this indicates	Take this action
Off	the channel is disabled for DeviceNet communication.	Power-up the module, provide network power to channel, and be sure channel is enabled in both the module configuration table and module command word.
Flashing green	the channel is enabled but no communication is occurring.	Configure scan list table for channel to add devices.
Solid green	all slave devices in the scan list table are communicating normally with the module.	None.
Solid red	the module may be defective.	Reset module. If failures continue, replace module.
Flashing red	at least one of the slave devices in the module's scan list table has failed to communicate with the module.	Examine the failed device and the scan list table for accuracy.

Your module uses numeric displays to indicate diagnostic information about the status of your module. The display flashes at 1 second intervals. The following table summarizes the meanings of the numeric codes.

Numeric Code	Indicates	Take this action
Network Address Displays 0 - 63	normal operation. The numeric display matches the scanner's node address on the DeviceNet network.	None.
70	module failed Duplicate Node Address check.	Change the module channel address to another available one. The node address you selected is already in use on that channel.
71	illegal data in scan list table (node number alternately flashes).	Reconfigure the scan list table and remove any illegal data.
72	slave device stopped communicating (node number alternately flashes).	Inspect the field devices and verify connections.
73	device key parameters do not match scan list table entry (node number alternately flashes).	Enter a matching scan list device ID. Make sure that the device at the flashing node address matches the desired key parameters (vendor, product code, product type).
74	data overrun on port detected.	Modify your configuration and check for invalid data.
75	no network traffic has been detected.	Verify connections.
76	no direct network traffic for module detected.	None. The module hears other network communication.
77	data size returned does not match scan lists entry (node number alternately flashes).	Reconfigure your module and change the addressing.
78	slave device in scan list table does not exist (node number alternately flashes).	Add the device to the network, or delete the scan list entry for that device.
79	module has failed to transmit a message.	Make sure that your module is connected to a valid network. Check for disconnected cables. Verify baud rate.
80	module is in IDLE mode.	None.
81	module is in FAULT mode.	None.
82	error detected in sequence of fragmented I/O messages from device (node number alternately flashes).	Check scan list table entry for slave device to make sure that input and output data lengths are correct. Check slave device configuration.
83	slave device is returning error responses when module attempts to communicate with it (node number alternately flashes).	Check accuracy of scan list table entry. Check slave device configuration.
84	module is initializing the DeviceNet channel.	None. This code clears itself once module attempts to initialize all slave devices on the channel.
85	data size returned is bigger than expected.	Check accuracy of scan list table entry. Check slave device configuration.
86	device is producing idle state data while the scanner is in Run Mode.	Check device configuration/slave node status.
87	available for allocation. Scanner has not yet been detected by allocated master, or slave mode is enabled but scanner is not allocated to a master.	Monitor scanner to determine if error code clears when master detects scanner. If error remains, check scanner slave mode configuration.
88	this is not an error. At power-up and reset, the module displays all 14 segments of the node address and status display LEDs.	None.

Table continued on the next page.

Numeric Code	Indicates	Take this action
90	user has disabled communication port	reconfigure your module. Check the disable bit in the Module Command Register.
91	bus-off condition detected on comm port. module is detecting communication errors.	Check DeviceNet connections and physical media integrity. Check system for failed slave devices or other possible sources of network interference.
92	no network power detected on comm port.	Provide network power. Make sure that module drop cable is providing network power to module comm port.
95	application FLASH update in progress.	None. Do not disconnect the module while application FLASH is in progress. You will lose any existing data in the module's memory.
97	module halted by user command.	None.
98	Unrecoverable firmware failure.	Service or replace your module.
99	Unrecoverable hardware failure.	Service or replace your module.

Communicating with an SLC 5/03 Processor on a DeviceNet Network using Explicit Messaging

Overview

This application describes how to connect and configure an AdaptaScan Bar Code Reader to communicate with an SLC 5/03 processor over a DeviceNet network in a master/slave mode using explicit messaging. A 4 character Interleaved 2 of 5 bar code symbol is used in this application.

The DeviceNet network has the following nodes:

- AdaptaScan Bar Code Reader on node 3
- 1771-SDN DeviceNet Scanner on node 1
- Computer running DeviceNet Manager Software on node 62.

The DeviceNet terminal block in the reader's wiring base connects the AdaptaScan Reader to the DeviceNet network. The wiring base has two DeviceNet terminal blocks; one for upstream connection and one for downstream connection.

Hardware Requirements

The hardware items required for this application are:

- 2755-SN3, -SN5 or -SN8 AdaptaScan Bar Code Reader
- 2755-NB40 or -NB41 Wiring Base
- 2755-PW46 or -PW47 Power Supply (if not power by DeviceNet)
- 2755-NC43 or -NC48 Configuration Cable
- 1747-SDN Scanner Module (v2.05 firmware or later)
- 1770-KFD DeviceNet RS-232 Interface
- DeviceNet trunk cable
- 1747 I/O chassis
- SLC 5/03 processor
- Computer running Windows 3.1 (or later) or Windows 95
- 9-to-25 Pin Adapter (for Computer with 25-pin COM port)

Software Requirements

The software requirements for this application are:

- 2755-ASN AdaptaScan Offline Programming Software (v8.0 or later)
- SLC Advanced Programming Software
- 1787-MGR DeviceNet Manager Software (v3.0 or later)

Related Publications

Related publications include:

Publication	Description
2755-837	AdaptaScan Bar Code Readers User Manual
2755-838	AdaptaScan Software User Manual
1787-6.5.3	DeviceNet Manager Software Manual
1747-6.5.2	1747-SDN DeviceNet Scanner Configuration Manual

In addition, you may want to refer to the SLC 500 Hardware and Software User Manuals.

Connecting to the DeviceNet Network

The following illustration shows the nodes of the DeviceNet master/slave network. Refer to the *1747-SDN DeviceNet Scanner Configuration Manual* (Publication No. 1747-6.5.2) for more information regarding user termination information.

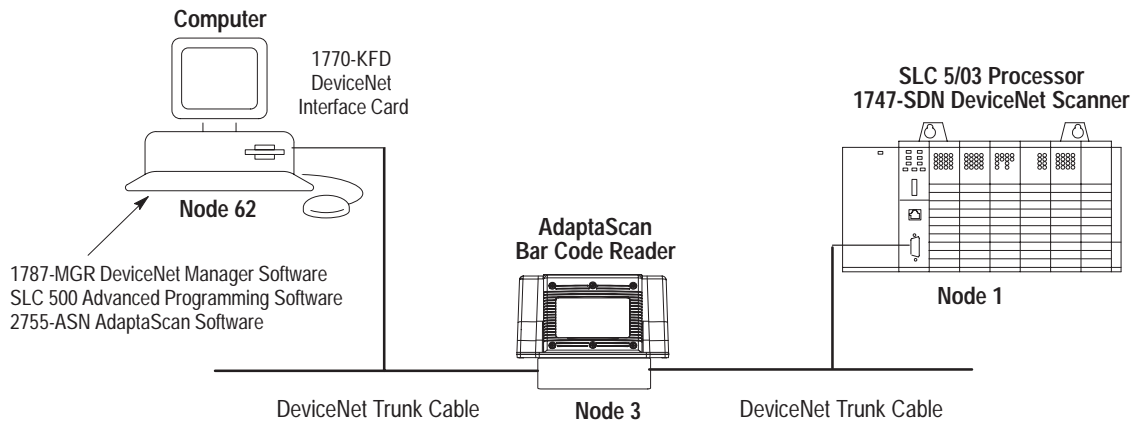

Connecting a Power Supply to the Reader

The following illustration shows how to connect a 2755-PW46 or -PW47 power supply to a single bar code reader.

Use a shielded cable (Belden 9316 recommended) to make the connections. Connect the shield to the ground screw on the reader's wiring base.

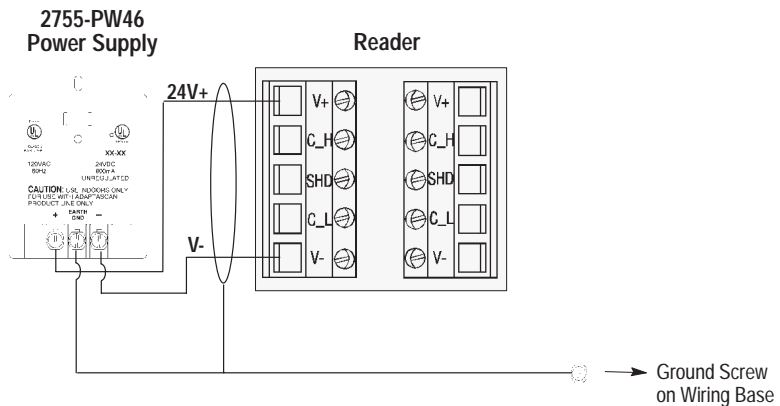

Note: Use a termination switch for DeviceNet in the wiring base for the end of the network.

SLC Ladder Logic

This section provides the SLC ladder logic program and data monitor results. The ladder logic uses:

- File N23 as the SLC interface to M1 file
- File N22 as the SLC interface to M0 file

The data table shows file N23 after the AdaptaScan Reader successfully reads and transfers data '0300' (from a 4 character, Interleaved 2 of 5 symbol) to the SLC data table.

File	Location	Description
Discrete Output O	Word 0 Bit 0	1=SDN card in run mode 0=SDN card in idle mode
N23	Word 0	Status word
	Word 1 Bit 15	'New Message Being Sent' bit from AdaptaScan Reader
N22	Word 0	Status word
	Word 1 Bit 7	'Send Message' bit to AdaptaScan Reader

Message AddressingB

Message Data is formatted the same as messages sent through the serial port. When setting up the DeviceNet scanner for addressing message data, use the following table.

Description	Word #	Byte # ^{①②}
Number of Characters (LSB)	2	2
Number of Characters (MSB)		3
First Message Character (Beginning of Message)	3	4
Other Message Characters from left to right		5 →
Last Message Character (End of Message)		3+N where N is the number of characters in the message.

^① Bytes #0 and #1 (word 1) are reserved for Discrete I/O.

^② Poll Rx Size = 4 + (# of Characters in string).

Message data is addressed and sent to other DeviceNet devices through a DeviceNet scanner (Catalog No. 1771-SDN or 1747-SDN). To configure the scanner, you will need to provide the size of the message data, the beginning byte and bit number of the message and the destination of the message data.

Message Flow Control

DeviceNet Input #8 and Output #16 control the transmission of bar code messages when using DeviceNet master-slave. Message flow control (handshaking) lets the controller know that data is available and that the reader does not send out messages faster than they can be received. Your controller logic program must transfer the message data and set the DeviceNet Input #8 (Send Next Data) for message flow control.

New Data

Is indicated by changing the state of DeviceNet Output #16 of the DeviceNet I/O. A change of state (0 to 1 or 1 to 0) indicates that a new message is being sent.

Send Next Data

Is indicated by changing the state of DeviceNet Input #8 of the DeviceNet I/O. A change of state (0 to 1 or 1 to 0) indicates that the controller is ready to receive the next message.

Flow Control Example

The following shows how DeviceNet Input #8 and Output #16 control the transmission of messages. Output #16 is changed by the reader and Input #8 is changed by the controller.

DeviceNet Scan Number	Message Data	DeviceNet Output #16	DeviceNet Input #8
1 - Poll	-		OFF (0)
1 - Response	No Message Sent	OFF (0)	
2 - Poll	-		ON (1)
2 - Response	Message 1 Sent	ON (1)	
3 - Poll	-		OFF (0)
3 - Response	Message 2 Sent	OFF (0)	

Note: The following ladder logic program is for reference only. Application specific interlocks may be necessary.

Rung 2:0

This rung enables Discrete Output bit 0 of slot 1. This will put the 1747-SDN card into run mode. Remember in order to "save to sdn" from the DeviceNet Manager Software you must disable this bit or put the processor into program mode.



Rung 2:1

This rung is toggled via the control bits sent from the AdaptaScan. Bit 15 in word 1 of N23 file is toggled when no data is being sent from adaptascan. It latches bit 7 in word 1 of N22 file to tell the adaptascan to send the next message.

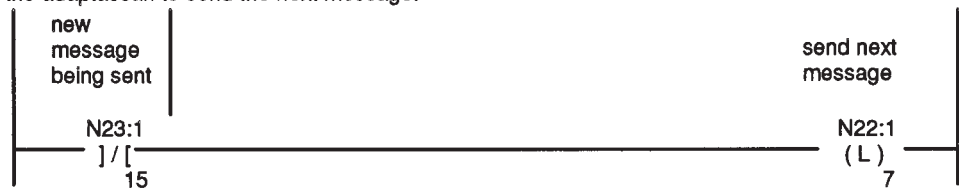

Rung 2:2

This rung transfers data from the m1 file to the n23:0 file.

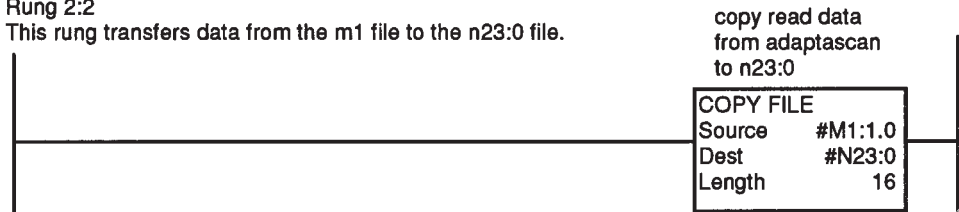

Rung 2:3

This rung transfers our control bits out to the adaptascan from n22 file

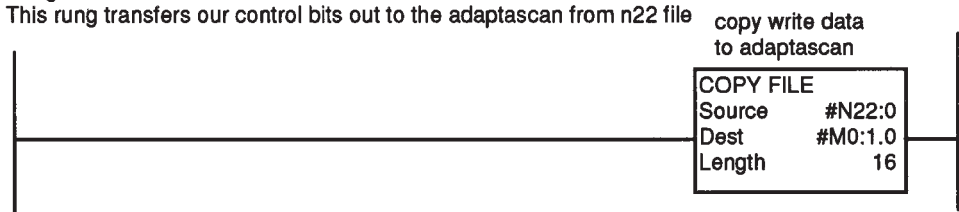

Rung 2:4

If a new message is currently being sent from the adaptascan this rung unlatches bit 7 in word 1 of N22 file. This tells the adaptascan that the sdn module is busy processing a previous message and not to send new message yet.



Rung 2:5



N23 Data Table File Monitor

In Data Table File N23:

- N23:1 contains the DeviceNet status bits
- Bit 15 is the control bit from the AdaptaScan Reader which toggles between 0 and 1 to indicate a ‘new message being sent’
- N23:2 is the byte count (4) of the message sent from the reader
- N23:3 is the start the of the data read 3000. Data is actually 0300. All data is byte swapped.

Note: The SLC instruction SWP can be used to swap the bar code data only.

1747-SDN to AdaptaScan Interface
Data Table

Processor File :MASTER.ACH

Data Table File N23

Address	Data (Radix = ASCII)		Processor File :MASTER.ACH				Data Table File N23					
N23:0	\00\00	\80\01	\00\04	3	0	0	0	\00\00	\00\00	\00\00	\00\00	\00\00
N23:10	\00\00	\00\00	\00\00	\00\00	\00\00	\00\00	\00\00	\00\00	\00\00	\00\00	\00\00	\00\00
N23:20	\00\00	\00\00	\00\00	\00\00	\00\00	\00\00	\00\00	\00\00	\00\00	\00\00	\00\00	\00\00
N23:30	\00\00	\00\00	\00\00	\00\00	\00\00	\00\00	\00\00	\00\00	\00\00	\00\00	\00\00	\00\00
N23:40	\00\00	\00\00	\00\00	\00\00	\00\00	\00\00	\00\00	\00\00	\00\00	\00\00	\00\00	\00\00
N23:50	\00\00	\00\00	\00\00	\00\00	\00\00	\00\00	\00\00	\00\00	\00\00	\00\00	\00\00	\00\00
N23:60	\00\00	\00\00	\00\00	\00\00	\00\00	\00\00	\00\00	\00\00	\00\00	\00\00	\00\00	\00\00
N23:70	\00\00	\00\00	\00\00	\00\00	\00\00	\00\00	\00\00	\00\00	\00\00	\00\00	\00\00	\00\00
N23:80	\00\00	\00\00	\00\00	\00\00	\00\00	\00\00	\00\00	\00\00	\00\00	\00\00	\00\00	\00\00
N23:90	\00\00	\00\00	\00\00	\00\00	\00\00	\00\00	\00\00	\00\00	\00\00	\00\00	\00\00	\00\00
N23:100	\00\00	\00\00	\00\00	\00\00	\00\00	\00\00	\00\00	\00\00	\00\00	\00\00	\00\00	\00\00
N23:110	\00\00	\00\00	\00\00	\00\00	\00\00	\00\00	\00\00	\00\00	\00\00	\00\00	\00\00	\00\00
N23:120	\00\00	\00\00	\00\00	\00\00	\00\00	\00\00	\00\00	\00\00	\00\00	\00\00	\00\00	\00\00
N23:130	\00\00	\00\00	\00\00	\00\00	\00\00	\00\00	\00\00	\00\00	\00\00	\00\00	\00\00	\00\00
N23:140	\00\00	\00\00	\00\00	\00\00	\00\00	\00\00	\00\00	\00\00	\00\00	\00\00	\00\00	\00\00
N23:150	\00\00	\00\00	\00\00	\00\00	\00\00	\00\00	\00\00	\00\00	\00\00	\00\00	\00\00	\00\00

N22 Data Table File Monitor

Below is a partial listing of the Data Table File N22. The table shows N22:1 bit 7 as the DeviceNet status bit which toggles between 0 and 1 to indicate ‘send next message’.

1747-SDN to AdaptaScan Interface

Data Table

Processor File: MASTER.ACH

Data Table File N22

Address	Data (Radix=BINARY)
N22:0	0 0 0 0 0 0 0 0 0 0 0 0 0 0 0 0
N22:1	0 0 0 0 0 0 0 0 1 0 0 0 0 0 0 0
N22:2	0 0 0 0 0 0 0 0 0 0 0 0 0 0 0 0
N22:3	0 0 0 0 0 0 0 0 0 0 0 0 0 0 0 0

Data Table File 0 Monitor

Below is a partial listing of the File 0 data table. The table shows that bit O:1/0 is set to enable run mode in the 1747-SDN Scanner (1=RUN; 0=IDLE).

1747-SDN to AdaptaScan Interface

Data Table	Processor File :MASTER.ACH	Data Table File 0
Address	Data (Radix = ASCII)	
O:1	\00101	
O:1.1	\00100	
O:1.2	\00100	
O:1.3	\00100	
O:1.4	\00100	
O:1.5	\00100	
O:1.6	\00100	
O:1.7	\00100	
O:1.8	\00100	
O:1.9	\00100	
O:1.10	\00100	
O:1.11	\00100	
O:1.12	\00100	
O:1.13	\00100	
O:1.14	\00100	
O:1.15	\00100	

Data Table File M1 Monitor

Below is a partial listing of the M1 data table.

- M1:1.1 contains the DeviceNet status bit
- M1:1.2 is the byte count (4) of a message
- M1:1.3 to M1:1.4 is data 0300 from the AdaptaScan Reader

1747-SDN to AdaptaScan Interface

Data Table	Processor File :MASTER.ACH	Data Table File M1:1
Address	Data (Radix = ASCII)	
M1:1	\00100	
M1:1.1	\80101	
M1:1.2	\00104	
M1:1.3	3 0	
M1:1.4	0 0	
M1:1.5	\00100	
M1:1.6	\00100	
M1:1.7	\00100	
M1:1.8	\00100	
M1:1.9	\00100	
M1:1.10	\00100	
M1:1.11	\00100	
M1:1.12	\00100	
M1:1.13	\00100	
M1:1.14	\00100	
M1O:1.15	\00100	

Configuring the DeviceNet Scanner

This section describes how to configure the 1747-SDN Scanner using the DeviceNet Manager software.

Before configuring the 1747-SDN Scanner, you must wire the DeviceNet network and apply DeviceNet Address 3 to the bar code reader. See page 10–16.

To configure the 1747-SDN DeviceNet Scanner:

1. Double-click the DeviceNet Manager icon.
2. Create a new project with the network name SLC503.
3. Click the Build Online button to create a DeviceNet network. The network should have the following nodes:
 - Node 1 – 1747-SDN Scanner Module
 - Node 3 – 2755-SN5 AdaptaScan Bar Code Reader
 - Node 62 – 1787-MGR DeviceNet Manager



4. Double-click the 1747-SDN Scanner Module to open the 1747-SDN Module Configuration dialog.

From this dialog, you modify all configuration parameters for the 1747-SDN Scanner.

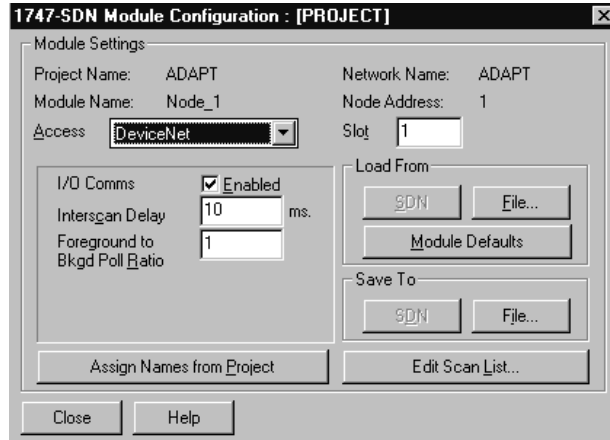

If you are using an AdaptaScan with v7.0 (or lower) firmware on a network with 2 or less nodes, change the Interscan Delay parameter to 20 ms. This will allow the AdaptaScan more CPU time to process bar code data instead of responding to DeviceNet polls.

5. Click the Edit Scan List button.



Note: Version 8.0 of the AdaptaScan Offline Programming Software and firmware minimizes DeviceNet polling interruption of scanning.

6. Click the Edit I/O Parameters button.

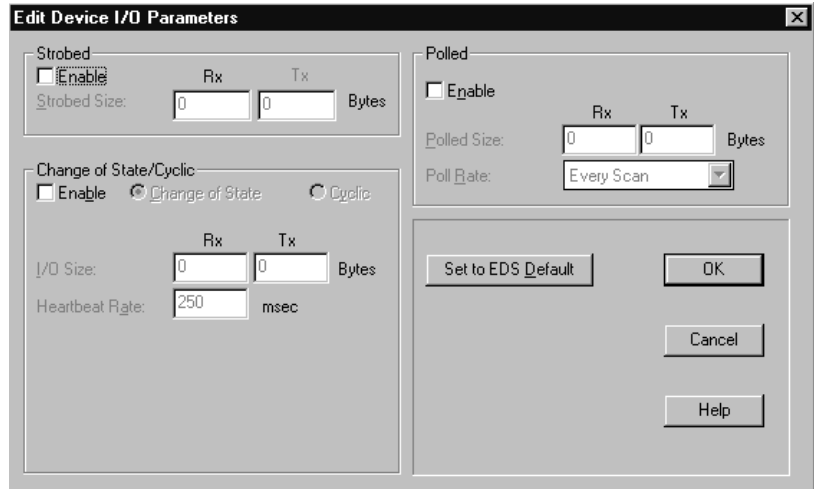

7. Click the Polled button.

8. Change the Poll Rx size to 8.

9. Change the Poll Tx size to 1.

10. Click the OK button to return to the Scan List Editor screen.

11. Click the Datable Map button.



12. Click the Data Entry button.
13. Change Map Data From to **Poll Message**.
14. Change Map Data To **M File**.
15. Change M1:1. to **1**.
16. Change No. Bits to **64**.
17. Click Apply Segment.



The dialog shows the data table map of the SLC M1 file. It displays data from the AdaptaScan Reader, which is mapped to the SLC (File N23).

Word 0 is reserved and 4 words (8 bytes) of the data table are mapped for the incoming string from the reader. Bit 15 is the 'new message being sent' bit.

18. Click the Output button.
19. Change Map Data From to **Poll Message**.
20. Change Map Data To **M File**.
21. Change M0:1. to **1**.
22. Change No. Bits to **8**.
23. Click Apply Segment button.



The dialog shows the data table map of the SLC M0 file. It displays data sent to the AdaptaScan Reader through the SDN Scanner (N22). 1 byte of data is written to the SDN Scanner.

Bit 7 of Word 1 is the 'send next message' bit.

24. Click the Close button to return to the Scanlist Editor dialog.
25. Click the Save to SDN button to download the scanlist to the 1747-SDN Scanner.

Important: Before clicking the Save to SDN button, the SDN Scanner must be in Idle Mode. Set bit O:0/1 in the SLC to 0. Another way to place the SDN Scanner in Idle Mode is to put the SLC into Program Mode.

Configuring the Reader

This section shows how to configure the AdaptaScan Bar Code Reader using the AdaptaScan Software (Catalog No. 2755-ASN).

The procedures in this section show how to:

- scan/decode 4 character, Interleaved 2 of 5 bar code symbols
- define a DeviceNet address
- configure the scanner
- trigger the decoder
- configure the format of messages and the message destination

Create a New Project

Create a new project named SLC DeviceNet for one AdaptaScan Bar Code Reader (Bar Code Reader 1).

1. Choose New from the Project menu to create a new project.
2. Click the New button to add a bar code reader (Bar Code Reader 1) to the project.

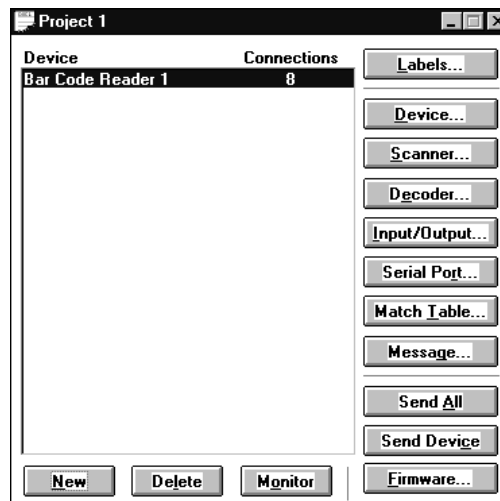

3. Choose Edit from the Project menu to rename the project **SLC DeviceNet**.

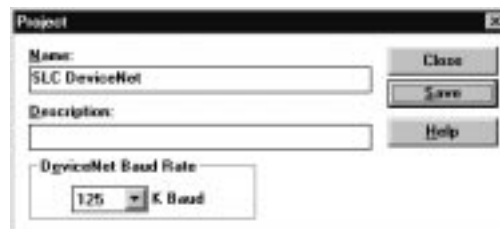

If you need to change the baud rate, proceed to the next section. If you do not need to change the baud rate, proceed to step 4.

4. Click Save to save the project under the new name and then Close to return to the Project dialog.

Change the Baud Rate

If you need to change the baud rate:

1. Click on the K Baud button and select the desired baud rate.

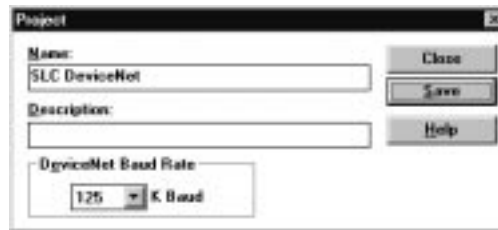

2. Click Save and Close to return to the Project dialog.
3. Click the Device button.
4. Click Apply if the desired baud rate is shown.
5. Click Save and Close to return to the Project dialog.
6. Click the Send Device button.

Define the Bar Code Label

1. Click the Labels button to open the Bar Code Labels dialog.
2. Click the New button to define a label.

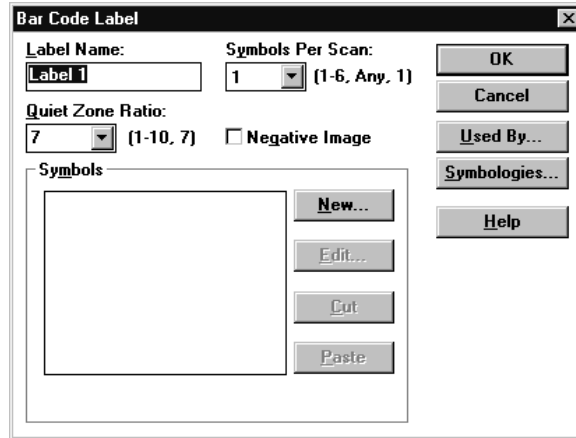

3. Click the New button to define a symbol for the label.

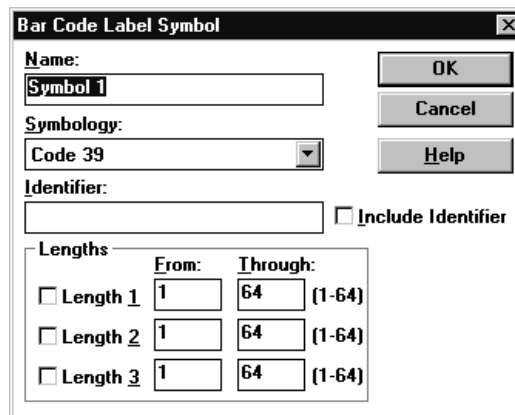

4. From the Symbology list, select **Interleaved 2 of 5**.
5. Under Lengths, select the **Length 1** check box and then type **4** in the Through box. This indicates a 4 character length for Interleaved 2 of 5 labels.
6. Click OK until you return to the Bar Code Labels dialog.
7. Click Save and then Close to return to the main Project dialog.

Define the DeviceNet Address

1. Click the Device button on the Project dialog.



2. Set the DeviceNet address to 3.
3. Connect the 2755-NC43 or -NC48 Configuration Cable to the reader.
4. Click the Apply button.
5. Click Save and Close to return to the Project dialog.

Configure the Scanner

1. Click the Scanner button on the Project dialog to open the Scanner dialog.

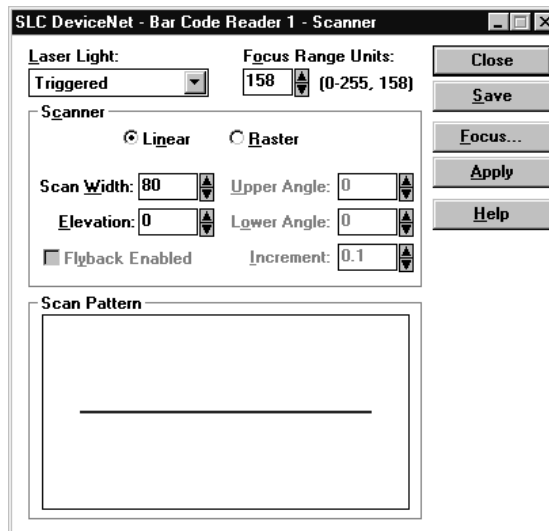

2. Configure the scan pattern and use the Focus procedure for optimum scanner focus.
3. Click the Close button and return to the Project dialog.

Configure the Decoder Trigger

To test the application, use the Timer to trigger the reader's decoder.

1. Click the Decoder button from the main Project dialog.
2. Under Triggered By, select **Timer** from the Input list.



3. Click the Save button.
4. Click the Close button and return to the main Project dialog.

Create a Message

Defines the content of messages sent from the reader to the 1747-SDN Scanner after bar codes have been decoded.

1. Click the Message button from the main Project dialog.
2. Under Triggered By, check the Enable check box.



3. Under Device, select **Bar Code Reader 1**.
4. Under Input, select **[Decoder]**.

- Click the New button to create a message field.



- Under Symbol Source, select **Bar Code Reader 1**.
- Under Bar Code Label & Symbols, select **Symbol 1**.
- Check (enable) the Match Exactly check box.
- Click the Edit button to open the Message Field Edit dialog.



- Under Replacement Strings, type **nr** in the Fail: field.

Bar code data is sent to the 1747-SDN Scanner on a valid read; the Fail string sends the characters “nr” to the 1747-SDN when a no read occurs.

- Under Data Format, type **4** in the Length box.

Important: The Length must match the number of characters in the bar code symbol. This application uses 4 character, Interleaved 2 of 5 symbols.

- Click OK to return to the Message Field dialog.
- Click OK to return to the Message dialog.

Define the Message Format

This section defines the format and destination of messages sent from the reader.

1. Click the Format button from the Message dialog.



The screenshot shows the 'Message Format' dialog box. It has a title bar with a close button. The dialog is divided into several sections: 'Header' with 'Header:' and 'Leader:' text boxes; 'Source ID:' with a text box; 'Field Definition' with a text box containing '44' and '(0-255, 44)' and a checked 'Dingle' checkbox; 'Message Destination' with radio buttons for 'DeviceNet' (selected), 'Serial Port', and a dropdown menu showing 'Bar Code Reader 1'; 'Include' with a checked 'Field Data' checkbox, an unchecked 'Include' checkbox, a 'Device:' dropdown menu, and a 'Counter:' dropdown menu. On the right side, there are 'OK', 'Cancel', and 'Help' buttons. At the bottom right, it says 'Current Message Size: 4'.

2. Under Message Destination, select **DeviceNet**.
3. Accept the defaults for all other parameters.
4. Click OK to return to the Message dialog.
5. Click OK again to return to the Message Field dialog.
6. Click Save and then Close to return to the main Project dialog.

Configure for Match Codes

1. Click the Match Table button to open the Match Table dialog.

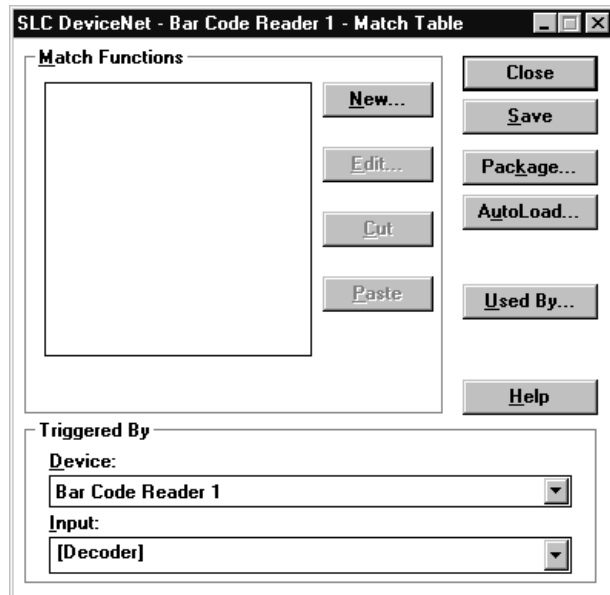

2. Click the New button to open the Match Function dialog and create a Match Function.

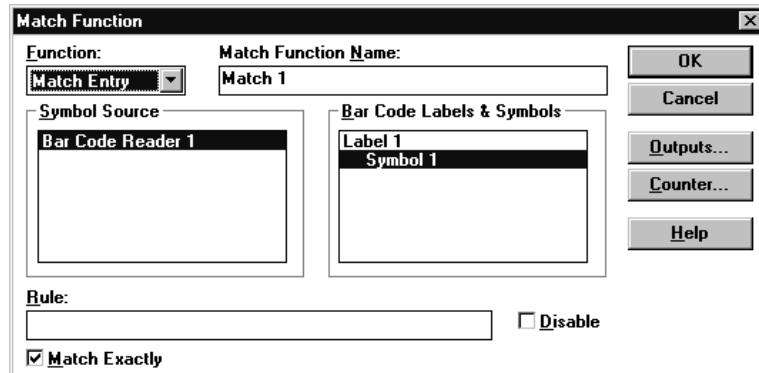

3. Under Function, select **Match Entry**.
Match Entry specifies that a match occurs whenever decoded bar code data matches the Rule: entry.
4. Under Symbol Source, select **Bar Code Reader 1**.
5. Under Bar Code Labels and Symbols, select **Symbol 1**.
6. Click the Match Exactly box.
Match Exactly specifies that ASCII characters are matched instead of a metacharacter rule.

- Click the Outputs button to specify which output activates when a match occurs.

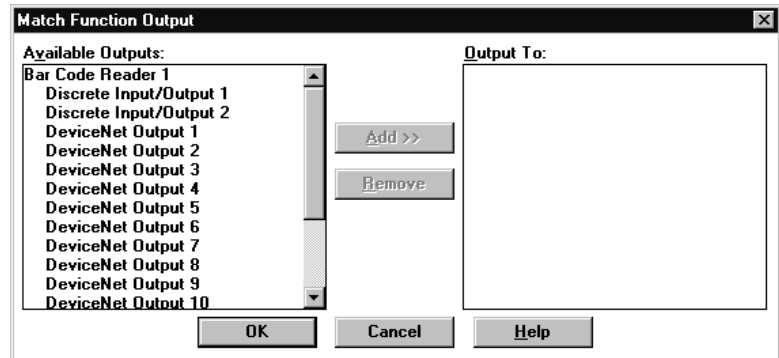

- Under Available Outputs, select **Discrete Input/Output 1**.
- Click the Add>> button to add this selection to the Output To: area.
- Click OK to return to the main Match Table dialog.

Configure for a Package

1. Click the Package button to open the Package dialog.

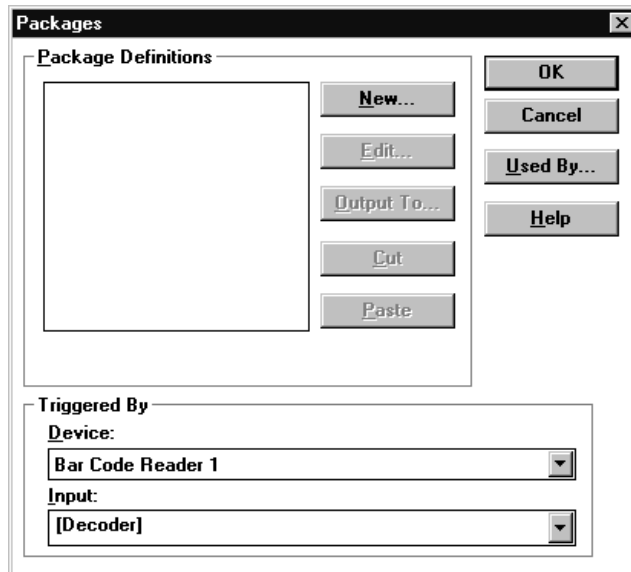

2. Click the new button to create a Package.
3. Under Mode, select **No-Read or No-Match**.
This mode is used to determine when a label is not read or does not match the rule defined in the Match function.
4. Highlight Match 1 to enable the Match function.

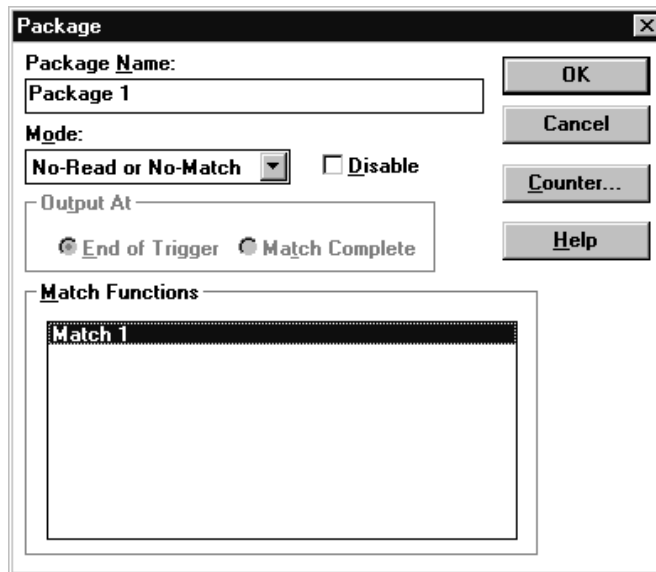

5. Click OK to return to the main Package dialog.

Configure for an Output

1. Click the Output To button to specify which output activates when a No-Read or No-Match occurs.

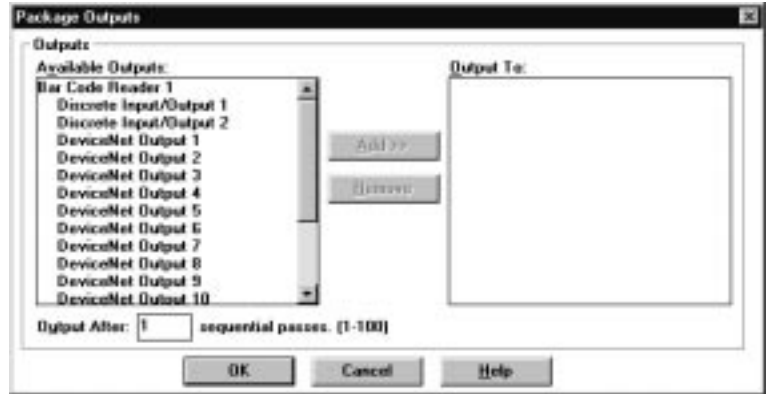

2. Under available Outputs, select **Discrete Input/Output 2**.
3. Click the Add>> button to add this selection to the Output To: area.
4. Click OK to return to the main Match Table dialog.
5. Click Save and Close to return to the main Project dialog.

Sending the Configuration to the Reader

From the main Project dialog, click the Send Device button to download the configuration to the bar code reader.

Use the Monitor dialog to verify the decoding of bar code labels.

Running the Application

If the:

- AdaptaScan Reader is configured correctly,
- the 1747-SDN Scanner is configured correctly, and
- the ladder program is entered as shown in this application,

you will see bar code data or 'nr' in the SLC M1 file (N23) as bar code symbols are decoded. Remember that all data is byte swapped. If the 1747-SDN Scanner is not working properly, refer to the troubleshooting section.

Explicit Message Program Control

Use the Explicit Message Program Control feature to configure device parameters on your DeviceNet network via the M0 and M1 files in the SLC processor that is controlling these devices.

You can use Explicit Message Program Control only with devices that are slaves of your 1747-SDN Scanner Module. These slave devices must be mapped in the scanner module's scan list.

Use the Explicit Message Program Control feature to:

- transmit configuration data from your scanner module to its slave devices on your DeviceNet network
- receive status and diagnostics from these devices on your DeviceNet network
- make runtime adjustments to device parameters according to changing conditions detected by your processor

Explicit Message Program Control Feature

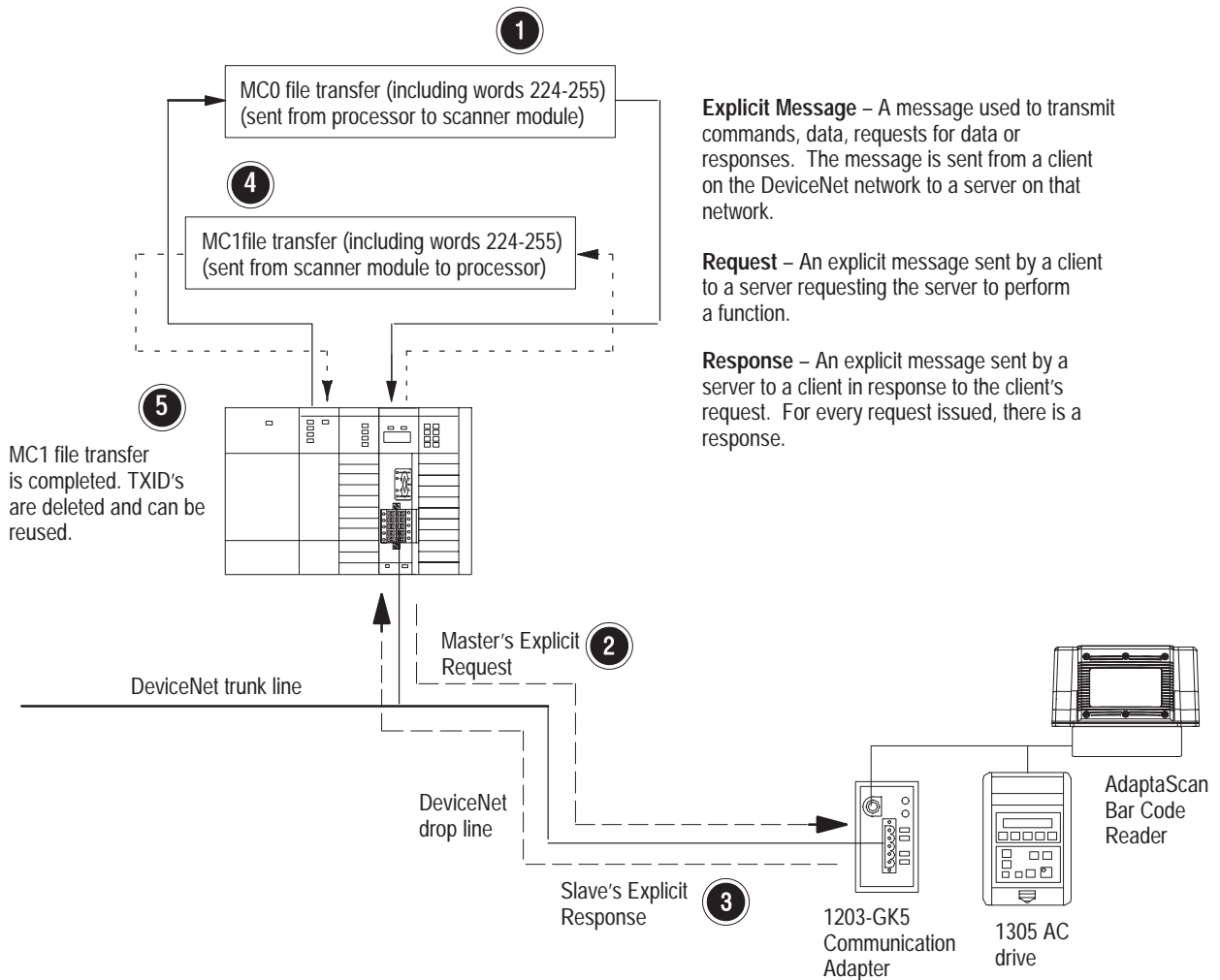

Explicit Message – A message used to transmit commands, data, requests for data or responses. The message is sent from a client on the DeviceNet network to a server on that network.

Request – An explicit message sent by a client to a server requesting the server to perform a function.

Response – An explicit message sent by a server to a client in response to the client's request. For every request issued, there is a response.

1. Format an M0 file transfer in the processor to send an Explicit Message Request to the scanner module (**download**).
2. The scanner module transmits the Explicit Message Request to the slave device over the DeviceNet network.
3. The slave device transmits the Explicit Message Response back to the scanner and is queued into a file transfer buffer.
4. The processor uses an M1 file transfer to retrieve the Explicit Message Response from the scanner's buffer (**upload**).
5. Format an M0 file transfer with a Delete Response Command and the current transaction ID read in step 4. The transaction IDs are deleted and can be reused.

Formatting the Explicit Message Transaction Block

Up to ten 32-word transaction blocks may be queued within the scanner module for Explicit Message Program Control. The transaction blocks accommodate both the download of Explicit Message Requests and the upload of Explicit Message Responses.

The scanner module can accommodate one request or response for each transaction block. You must format each transaction block as shown in the following figure.

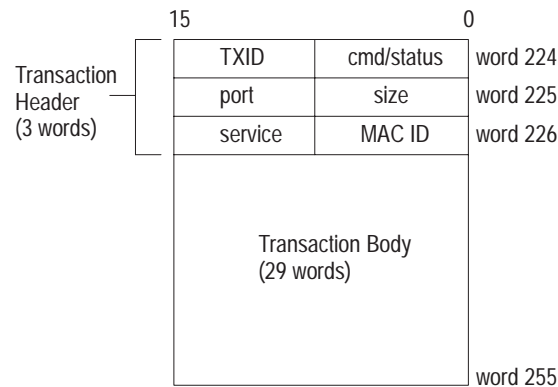

One word = two bytes = 16 bits

The transaction block is divided into two parts:

- **transaction header** – Contains information that identifies the transaction to the scanner and processor.
- **transaction body** – In a request, this contains the DeviceNet Class, Instance, Attribute and Service Data portion of the transaction. In a response, this contains only the response message.

Each of the data attributes in the transaction header are one byte in length:

- **command/status** – For each download, you assign a command code to instruct the scanner how to administer the request.

Command Code	Description
0	Ignore transaction block (block empty).
1	Execute this transaction block.
2	Get status of transaction TXID.
3	Reset all client/server transactions.
4	Delete transaction from response queue.
5-255	Reserved

For each upload, the status code provides the processor with status on the device and its response.

Status Code	Description
0	Ignore transaction block (block empty).
1	Transaction completed successfully
2	Transaction in progress (not ready)
3	Error – slave not in scan list
4	Error – slave offline
5	Error – DeviceNet port disabled/offline
6	Error – transaction TXID unknown
7	Unused
8	Error – Invalid command code
9	Error – Scanner out of buffers
10	Error – Other Client/server transaction in progress
11	Error – could not connect to slave device
12	Error – response data too large for block
13	Error – invalid port
14	Error – invalid size specified
15	Error – connection busy
16–255	Reserved

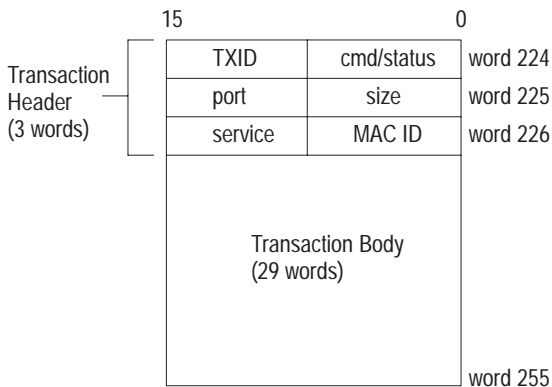

One word = two bytes = 16 bits

- TXID (transaction ID)** – When you create and download a request to the scanner, the processor’s ladder logic program assigns a TXID to the transaction. This is a one-byte integer in the range of 1 to 255. The scanner uses this value to track the transaction to completion, and returns the value with the response that matches the request downloaded by the processor. The ladder logic program monitors rollover and usage of TXID values.
- size** – The size of the transaction body in bytes. The transaction body can be as many as 29 words (58 bytes) in length. If the size exceeds 29 words, an error code will be returned.
- port** – The DeviceNet port (zero) where the transaction is routed.
- MAC ID (node address)** – The DeviceNet network address of the slave device where the transaction is sent. This value can range from 0 to 63. The port and MAC ID attributes coupled together identify the target slave device. The slave device must be listed in the scanner module’s scan list and be online for the Explicit Message transaction to be completed successfully.
- service** – For each Explicit Message Request and Response, the service attribute contains the service request and response codes that match the corresponding request for the TXID.

The following figure describes the format and mapping of transaction blocks for request and response messages in the scanner module.

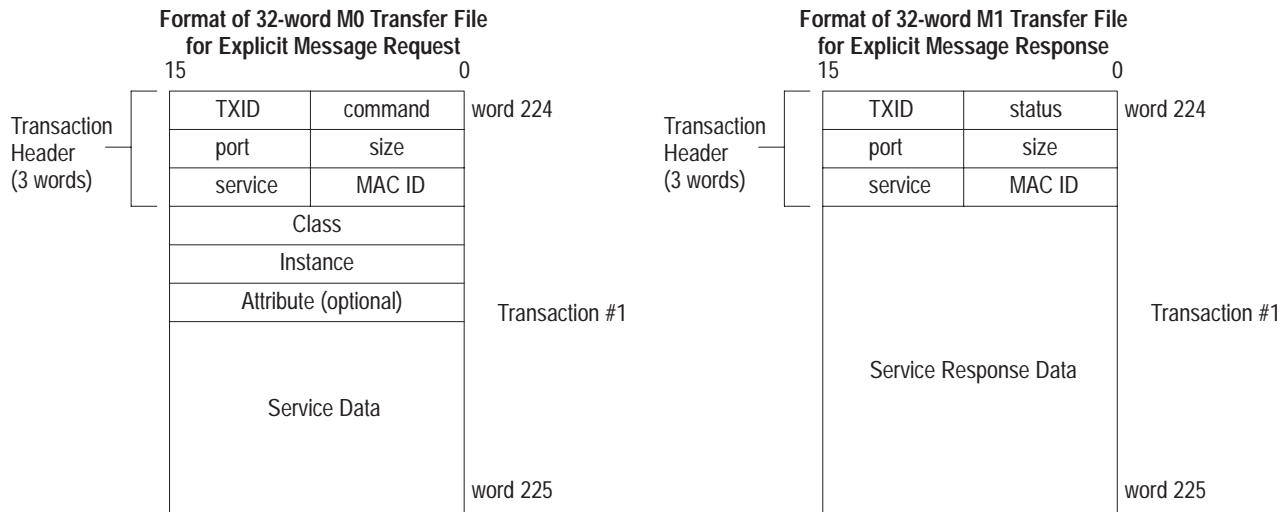

Processor and Scanner Module Manage Messages

File transfer operations between the processor and the scanner always originate in the processor. The scanner module can only wait for the processor to download a transaction block to the module or request an upload of a transaction block from the module.

Once an Explicit Message Request transaction block is downloaded to the scanner module, a ladder logic program in the processor polls the scanner module for the transaction block containing the Explicit Message Response for that request. This is done by the processor with an M1 file transfer on the scanner module. Depending on the network load, the scanner could take a few seconds to complete the request. When a response is loaded, bit 15 of the module status register is set to 1. The program may have to poll the scanner module a number of times before the scanner returns a Response Transaction Block.

The scanner module recognizes I/O data and control as higher priorities over explicit messaging on DeviceNet.

Message lengths and slave device types impact transaction message completion times. If the processor has queued multiple Explicit Message Transactions to the scanner module for multiple slave devices, the transactions with the slaves may not complete in the order in which the requests were received. The slave responses are queued to the 32 word M1 file transfer in the order in which they are received. As response transaction blocks are uploaded, the processor's program matches the responses to the requests using the TXID field.

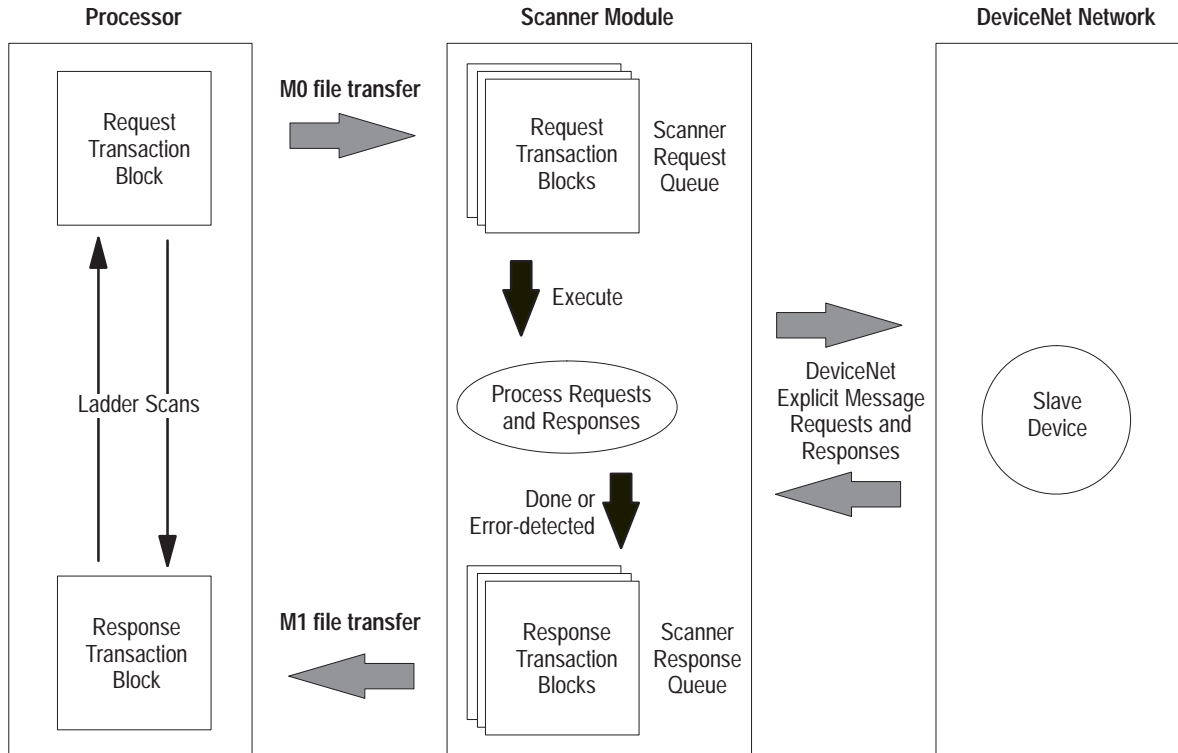

Explicit Message Program Control Limitations

- The processor is always the DeviceNet client and the slave is always the DeviceNet server.
- A maximum of 10 Explicit Message Request Transaction Blocks with the execute command can be queued to the scanner module at any time. For example, 10 M0 file transfers containing one transactions each, can be queued at any time. The scanner module receives and deletes any additional client/server requests with the execute command over the maximum of 10.

As transactions are removed from the queue and response transaction blocks are returned to the processor, additional transaction blocks can be issued in their place, as long as the total does not exceed ten.

- The scanner module supports one transaction block per upload and download.
- Request Transaction Blocks can only be queued for slave devices of the scanner module and must appear in the scanner module's scan list.
- If a slave device is not communicating at the time the scanner module processes its Request Transaction Block, the scanner module will return an error status for that transaction.
- At a minimum, the scanner module supports the following DeviceNet services in Request Transaction Blocks.

Service Name	Service Code	Example
Get_Attribute_Single	0E _{hex}	Upload a single parameter value from a device
Set_Attribute_Single	10 _{hex}	Download a single parameter value to a device
Get_Attribute_All	01 _{hex}	Upload all parameter values from a device
Set_Attribute_All	02 _{hex}	Download all parameter values to a device

- All transaction blocks are processed, therefore, an unused transaction block must be left blank.
- Client/Server commands and requests with transaction IDs that are in use are ignored by the scanner module.
- If a slave device returns a DeviceNet error in response to the request downloaded from the processor, the scanner recognizes the error as a successful transaction (status code =1).

A failure to respond to the request within the number of retries or timeout period specified for the Explicit Message Connection is recognized by the scanner module as an error. The error code is returned in the status attribute of the transaction header.

Explicit Messaging Ladder Logic Program

Note: The following ladder logic program is for reference only. Application specific interlocks may be necessary.

Enable Rung B3 to initiate the writing of an APM command to the AdaptaScan. The APM command that resides in N20:0. The DeviceNet address being written to, in this example is, 10 or 0AH.

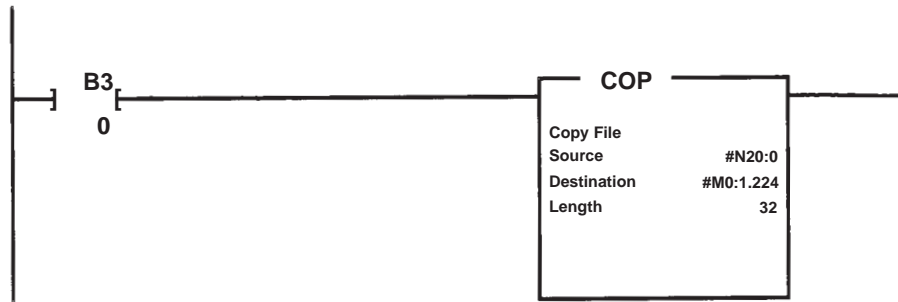

If bit 15 is enabled, read the response data from the above command into file N25:0.

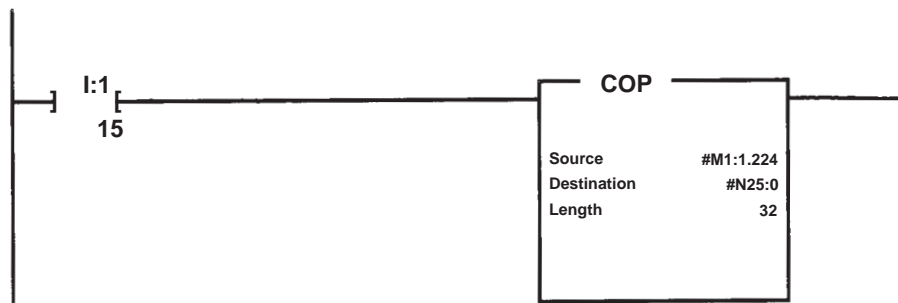

Example Data Tables

Refer to p. 10-27 for information regarding each byte.

Address	Data = Hex Code (matchcode download of 0300 data)								
N20:0	0101	000C	100A	00CE	0001	0003	0004	3330	3030

Address	Response File (good response)	
N25:0	0101	900C

Address	Data = Hex Code (turn on LED1)						
N20:0	0101	0008	100A	00C9	0002	0003	0001

Note: You need to send a reset command for every explicit command that is executed in order to receive a good response.

Notes on using Explicit Messaging

- You can send messages sequentially from the SLC 5/03 to different bar code readers, but the response will not update properly (when the response is read in N25:0).
- The TXID byte does not need to be incremented, although you may not know where the response came from.
- To receive the correct response from the command sent from the SLC 5/03 you must:
 1. Send command down, matchcode download (TXID=11).
 2. Send a 03 in the status command. Refer to page 10-26 for more information.
 3. Increment TXID to 12.
 4. Send command down, turn on LED 1 (TXID=12).
 5. View N25:0 for response to step 4.
 6. Confirm that TXID=12. If your response is 90, the command was sent correctly. If you receive a 94, the was not sent correctly.
- If an incorrectly formatted command is sent from the SLC 5/03, you must send a 03 in the status command byte in order for the system to operate properly.
- When sending a 03 in the status command byte, the SDN card will produce an error until the next command is sent.

Troubleshooting the Module and Network

The bicolor (green/red) module status indicator (MODULE) displays module status. It indicates whether the module has power and is functioning properly.

If the Module LED is	this indicates	Take this action
Off	there is no power applied to the module.	Apply power.
Solid green	the module is operating in normal condition.	None
Flashing green	the module is not configured.	Configure the module.
Flashing red	there is invalid configuration.	Check configuration setup.
Solid red	the module has an unrecoverable fault.	Replace the module.

The DeviceNet channel has a bicolor (green/red) network status indicator (NET). The next table provides troubleshooting information about the DeviceNet channel communication link.

If the NET indicator is	this indicates	Take this action
Off	the channel is disabled for DeviceNet communication.	Power-up the module, provide network power to channel, and be sure channel is enabled in both the module configuration table and module command word.
Flashing green	the channel is enabled but no communication is occurring.	Configure scan list table for channel to add devices.
Solid green	all slave devices in the scan list table are communicating normally with the module.	None.
Solid red	the module may be defective.	Reset module. If failures continue, replace module.
Flashing red	at least one of the slave devices in the module's scan list table has failed to communicate with the module.	Examine the failed device and the scan list table for accuracy.

Your module uses numeric displays to indicate diagnostic information about the status of your module. The display flashes at 1 second intervals. The following table summarizes the meanings of the numeric codes.

Numeric Code	Indicates	Take this action
Network Address Displays 0 - 63	normal operation. The numeric display matches the scanner's node address on the DeviceNet network.	None.
70	module failed Duplicate Node Address check.	Change the module channel address to another available one. The node address you selected is already in use on that channel.
71	illegal data in scan list table (node number alternately flashes).	Reconfigure the scan list table and remove any illegal data.
72	slave device stopped communicating (node number alternately flashes).	Inspect the field devices and verify connections.
73	device key parameters do not match scan list table entry (node number alternately flashes).	Enter a matching scan list device ID. Make sure that the device at the flashing node address matches the desired key parameters (vendor, product code, product type).
74	data overrun on port detected.	Modify your configuration and check for invalid data.
75	no network traffic has been detected.	Verify connections.
76	no direct network traffic for module detected.	None. The module hears other network communication.
77	data size returned does not match scan lists entry (node number alternately flashes).	Reconfigure your module and change the addressing.
78	slave device in scan list table does not exist (node number alternately flashes).	Add the device to the network, or delete the scan list entry for that device.
79	module has failed to transmit a message.	Make sure that your module is connected to a valid network. Check for disconnected cables. Verify baud rate.
80	module is in IDLE mode.	None.
81	module is in FAULT mode.	None.
82	error detected in sequence of fragmented I/O messages from device (node number alternately flashes).	Check scan list table entry for slave device to make sure that input and output data lengths are correct. Check slave device configuration.
83	slave device is returning error responses when module attempts to communicate with it (node number alternately flashes).	Check accuracy of scan list table entry. Check slave device configuration.
84	module is initializing the DeviceNet channel.	None. This code clears itself once module attempts to initialize all slave devices on the channel.
85	data size returned is bigger than expected.	Check accuracy of scan list table entry. Check slave device configuration.
86	device is producing idle state data while the scanner is in Run Mode.	Check device configuration/slave node status.
87	available for allocation. Scanner has not yet been detected by allocated master, or slave mode is enabled but scanner is not allocated to a master.	Monitor scanner to determine if error code clears when master detects scanner. If error remains, check scanner slave mode configuration.
88	this is not an error. At power-up and reset, the module displays all 14 segments of the node address and status display LEDs.	None.

Table continued on the next page.

Numeric Code	Indicates	Take this action
90	user has disabled communication port	reconfigure your module. Check the disable bit in the Module Command Register.
91	bus-off condition detected on comm port. module is detecting communication errors.	Check DeviceNet connections and physical media integrity. Check system for failed slave devices or other possible sources of network interference.
92	no network power detected on comm port.	Provide network power. Make sure that module drop cable is providing network power to module comm port.
95	application FLASH update in progress.	None. Do not disconnect the module while application FLASH is in progress. You will lose any existing data in the module's memory.
97	module halted by user command.	None.
98	Unrecoverable firmware failure.	Service or replace your module.
99	Unrecoverable hardware failure.	Service or replace your module.

Downloading Other Host Commands

You can download other host commands using the same procedures described in the match code example. The following tables provide the commands and responses for the other host commands (all values are hexadecimal).

Read Performance Indicator Command

Packet Contents	Data Sent
DeviceNet Address	3F*
Get Performance Request	4C
Class	C8
Instance Number (LSB)	01
Instance Number (MSB)	00

*3F = Address 63, modify as required

Read Performance Indicator Response

Packet Contents	Response
DeviceNet Address	3F
Get Performance Response	CC
Data (LSB)	01
Data (MSB)	00

Reset Package Counter Command

Packet Contents	Data Sent
DeviceNet Address	3F*
Set Attribute Request	10
Class	D2
Instance Number (LSB)	00
Instance Number (MSB)	00
Attribute Number- Reset Counters	09
Data	01

*3F = Address 63, modify as required

Reset Package Counter Response

Packet Contents	Response
DeviceNet Address	3F
Set Attribute Response	90

Read Match Counters Command

Packet Contents	Data Sent
DeviceNet Address	3F*
Get Attribute Request	0E
Class	CE
Instance Number (LSB)	01
Instance Number (MSB)	00
Attribute Number	08

*3F = Address 63, modify as required

Read Match Counters Response

Packet Contents	Response
DeviceNet Address	3F
Get Attribute Response	8E
Data	6C, 08, 00, 00

Read Package Counters Command

Packet Contents	Data Sent
DeviceNet Address	3F*
Get Attribute Request	0E
Class	D2
Instance Number (LSB)	01
Instance Number (MSB)	00
Attribute Number- Match Count	08

*3F = Address 63, modify as required

Read Package Counters Response

Packet Contents	Response
DeviceNet Address	3F
Get Attribute Response	8E
Data	6C, 08, 00, 00

Reset Match Counters Command

Packet Contents	Data Sent
Response Codes	3F*
Set Attribute Request	10
Class	CE
Instance Number (LSB)	00
Instance Number (MSB)	00
Attribute Number- Reset Counters	0B
Data	01

*3F = Address 63, modify as required

Read Message Command

Packet Contents	Data Sent
DeviceNet Address	3F*
Get Attribute Request	0E
Class	CC
Instance Number (LSB)	00
Instance Number (MSB)	00
Attribute Number - Message	14

*3F = Address 63, modify as required

Read LED Status Command

Packet Contents	Data Sent
DeviceNet Address	3F*
Read LEDS Request	43
Class	CB
Instance Number (LSB)	01
Instance Number (MSB)	00

*3F = Address 63, modify as required

Reset Match Counters Response

Packet Contents	Response
DeviceNet Address	3F
Set Attribute Response	90

Read Message Response

Packet Contents	Response
DeviceNet Address	3F
Get Attribute Response	8E
Data (LSB)	04
Data (MSB)	00
ASCII Message Data	30*
ASCII Message Data	32
ASCII Message Data	30
ASCII Message Data	30

* Example data = 0200

Read LED Status Response

Packet Contents	Response
3F	3F
Read LEDS Response	C3
I/O 1	See Table Next Page
I/O 2	See Table Next Page
Trigger / Read	See Table Next Page
On Symbol	See Table Next Page
Laser On	See Table Next Page
Module	See Table Next Page
Network	See Table Next Page

Set Output Timer Command

Packet Contents	Data Sent
DeviceNet Address	3F*
Set Attribute Request	10
Class	D0
Instance Number (LSB)	02
Instance Number (MSB)	00
Attribute Number - Max Time	09
Data (LSB)	FA
Data (MSB)	00

*3F = Address 63, modify as required

** Time in milliseconds

Set Output Timer Response

Packet Contents	Response
DeviceNet Address	3F
Set Attribute Response	90

LED Status Response

Byte	Bits	LED Indicator	Data at Indicated Bit Address = LED State							
			0 = Off	1 = Yellow	2 = Green	3 = Red	4 = Not Used	5 = Flash Yellow	6 = Flash Green	7 = Flash Red
0	0-2	I/O 1	OFF	ON						
	3-5	I/O 2	OFF	ON						
1	0-2	TRIGGER / READ	No Trigger	Triggered	Valid Read					
	3-5	ON SYMBOL	Not Reading	Reading				Read <100%		
2	0-2	LASER ON	OFF	ON						
	3-5	MODULE	No Power		Device OK	Hardware Fault			Power Up	Minor Fault
3	0-2	NETWORK			DeviceNet OK	DeviceNet Fault			Established	No Response
	3-5									

Communicating with a PLC-5 Processor on a DeviceNet Network

Overview

This application describes how to connect and configure an AdaptaScan Bar Code Reader to communicate with a PLC-5 processor over a DeviceNet network in a master/slave mode. A 4 character Interleaved 2 of 5 bar code symbol is used in this application.

The DeviceNet network has the following nodes:

- AdaptaScan Bar Code Reader on node 3
- 1771-SDN DeviceNet Scanner on node 1
- Computer running DeviceNet Manager Software on node 62

The DeviceNet terminal block in the reader's wiring base connects the AdaptaScan Reader to the DeviceNet network. The wiring base has two DeviceNet terminal blocks; one for upstream connection and one for downstream connection.

Hardware Requirements

The hardware items required for this application are:

- 2755-SN3, -SN5 or -SN8 AdaptaScan Bar Code Reader
- 2755-NB40 or -NB41 Wiring Base
- 2755-PW46 or -PW47 Power Supply
- 2755-NC43 or -NC48 Configuration Cable
- 1771-SDN Scanner Module (v3.04 firmware or later)
- 1770-KFD DeviceNet RS-232 Interface
- DeviceNet trunk cable
- 1771 I/O chassis
- PLC-5 processor
- Computer running Windows 3.1 (or later) or Windows 95
- 9-to-25 Pin Adapter (for Computer with 25-pin COM port)

Software Requirements

The software requirements for this application are:

- 2755-ASN AdaptaScan Offline Programming Software (v8.0 or later)
- 6200 Series Programming Software
- 1787-MGR DeviceNet Manager Software (v3.0 or later)

Related Publications

Related publications include:

Publication	Description
2755-837	AdaptaScan Bar Code Readers User Manual
2755-838	AdaptaScan Software User Manual
1787-6.5.3	DeviceNet Manager Software Manual
1771-6.5.118	DeviceNet Scanner Configuration Manual

In addition, you may want to refer to the PLC-5 Hardware and Software User Manuals.

Connecting to the DeviceNet Network

The following illustration shows the three nodes of the DeviceNet master/slave network.

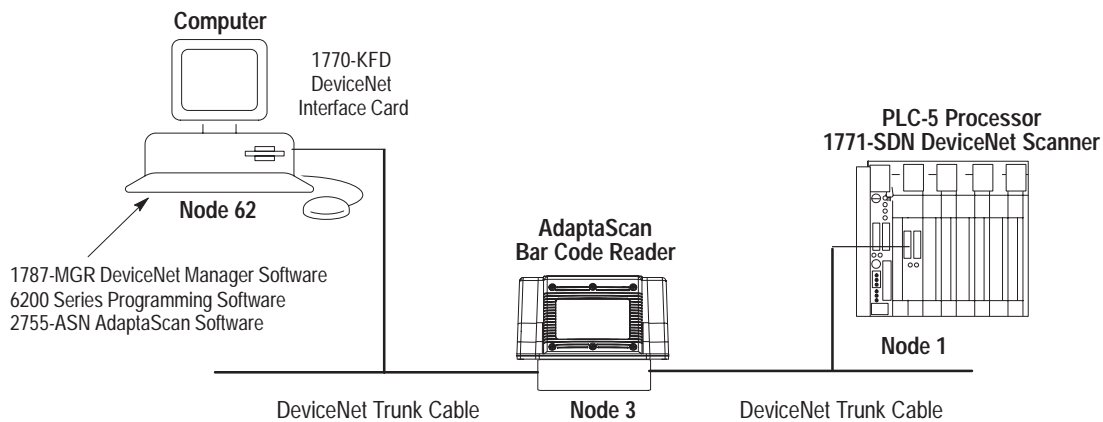

Connecting a Power Supply to the Reader

The following illustration shows how to connect a 2755-PW46 or -PW47 power supply to a single bar code reader.

Use a shielded cable (Belden 9316 recommended) to make the connections. Connect the shield to the ground screw on the reader's wiring base.

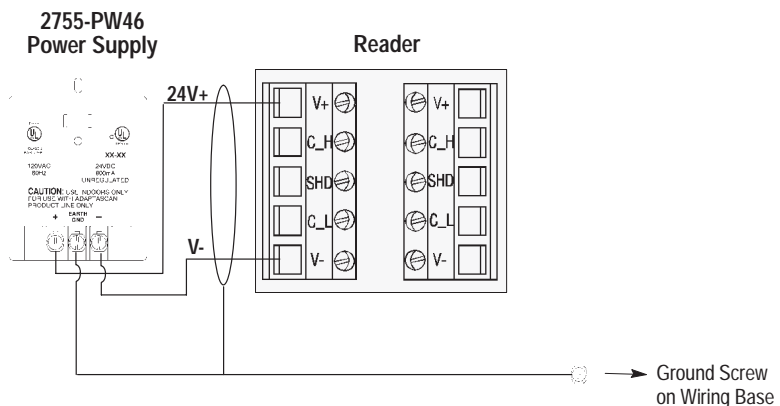

PLC Ladder Logic

This section provides the PLC-5 ladder logic program and data monitor results. The ladder logic uses:

- File N23 as the BTR file
- File N22 as the BTW file

The data table shows file N23 after the AdaptaScan Reader successfully reads and transfers data '0300' (from a 4 character, Interleaved 2 of 5 symbol) to the PLC-5 data table.

File	Location	Description
N23	Word 0	Status word for SDN Scanner
	Word 1 Bit 15	'New Message Being Sent' bit from AdaptaScan Reader
N22	Word 0	Status word
	Word 0 Bit 0	1=SDN Scanner in run mode 0=SDN Scanner in idle mode Idle mode is used to write the DeviceNet configuration to the SDN Scanner.
	Word 1 Bit 7	'Send Message' bit to AdaptaScan Reader

Message Addressing

Message Data is formatted the same as messages sent through the serial port. When setting up the DeviceNet scanner for addressing message data, use the following table.

Description	Word #	Byte # ^{①②}
Number of Characters (LSB)	2	2
Number of Characters (MSB)		3
First Message Character (Beginning of Message)	3	4
Other Message Characters from left to right		5 →
Last Message Character (End of Message)		3+N where N is the number of characters in the message.

^① Bytes #0 and #1 (word 1) are reserved for Discrete I/O.

^② Poll Rx Size = 4 + (# of Characters in string).

Message data is addressed and sent to other DeviceNet devices through a DeviceNet scanner (Catalog No. 1771-SDN or 1747-SDN). To configure the scanner, you will need to provide the size of the message data, the beginning byte and bit number of the message and the destination of the message data.

Message Flow Control

DeviceNet Input #8 and Output #16 control the transmission of bar code messages when using DeviceNet master-slave. Message flow control (handshaking) lets the controller know that data is available and that the reader does not send out messages faster than they can be received. Your controller logic program must transfer the message data and set the DeviceNet Input #8 (Send Next Data) for message flow control.

New Data

Is indicated by changing the state of DeviceNet Output #16 of the DeviceNet I/O. A change of state (0 to 1 or 1 to 0) indicates that a new message is being sent.

Send Next Data

Is indicated by changing the state of DeviceNet Input #8 of the DeviceNet I/O. A change of state (0 to 1 or 1 to 0) indicates that the controller is ready to receive the next message.

Flow Control Example

The following shows how DeviceNet Input #8 and Output #16 control the transmission of messages. Output #16 is changed by the reader and Input #8 is changed by the controller.

DeviceNet Scan Number	Message Data	DeviceNet Output #16	DeviceNet Input #8
1 - Poll	-		OFF (0)
1 - Response	No Message Sent	OFF (0)	
2 - Poll	-		ON (1)
2 - Response	Message 1 Sent	ON (1)	
3 - Poll	-		OFF (0)
3 - Response	Message 2 Sent	OFF (0)	

Note: The following ladder logic program is for reference only. Application specific interlocks may be necessary.

Rung 2:0

This rung is toggled via the control bits sent from the AdaptaScan. Bit 15 of word 1 is toggled when no data is being sent from adaptascan. It latches bit 7 if word 1 in our Block Transfer Write file. This tells the adaptascan to send the next message.



Rung 2:1

This rung block transfers our data from the 1771-SDN scanner card to the PLC address N23:0. Length is corresponding to the type of block transfer executed in the SDN scanner card. This is done via the DeviceNetManager software.

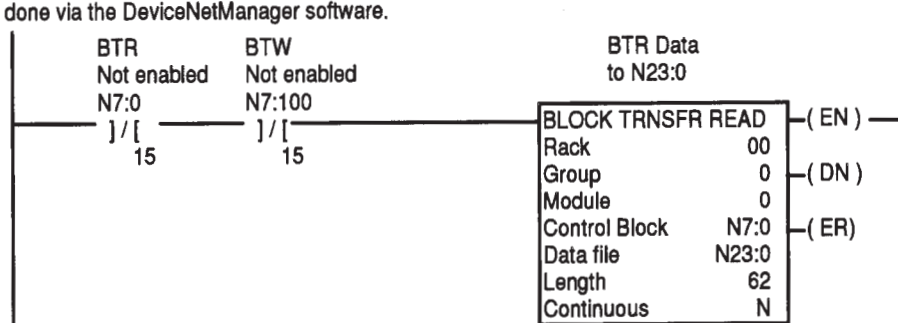

Rung 2:2

This rung executes a BTW from our N22 file. This sends the status of bit 7 to the scanner card to tell the adaptascan it can send its next message. Also very important: bit 0 of word 0 needs to be set to 1 in order to put the SDN scanner card in run mode.

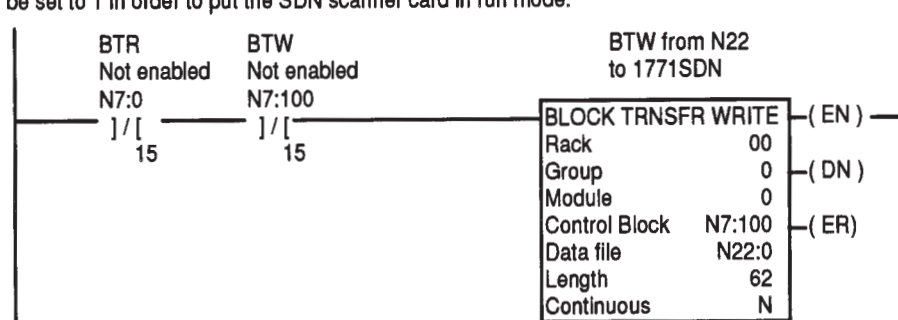

Rung 2:3

If a new message is being sent this rung unlatches our bit 7 in the BTW file telling the adaptascan the SDN module/PLC is busy processing a previous message

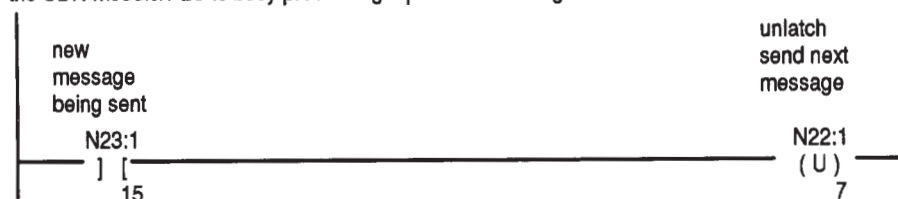

Rung 2:4

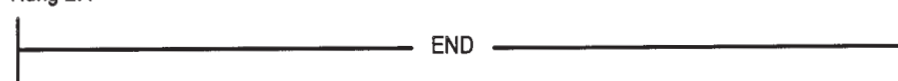

Note: If you are using channel B instead of channel A, bit 2 of word 0 needs to be set to 1.

Data Table File N23 Monitor

In Data Table File N23:

- N23:1 contains the DeviceNet status bits
- Bit 15 is the control bit from the AdaptaScan Reader which toggles between 0 and 1 to indicate a ‘new message being sent’
- N23:2 is the byte count (4) of the message sent from the reader
- N23:3 is the start the of the data read 3000. Data is actually 0300. All data is byte swapped.

1771-SDN to AdaptaScan Interface

Data Table	Processor File :MASTER.ACH					Data Table File N23						
Address	Data (Radix = ASCII)											
N23:0	\00\00	\80\01	\00\04	3	0	0	0	\00\00	\00\00	\00\00	\00\00	\00\00
N23:10	\00\00	\00\00	\00\00	\00\00	\00\00	\00\00	\00\00	\00\00	\00\00	\00\00	\00\00	\00\00
N23:20	\00\00	\00\00	\00\00	\00\00	\00\00	\00\00	\00\00	\00\00	\00\00	\00\00	\00\00	\00\00
N23:30	\00\00	\00\00	\00\00	\00\00	\00\00	\00\00	\00\00	\00\00	\00\00	\00\00	\00\00	\00\00
N23:40	\00\00	\00\00	\00\00	\00\00	\00\00	\00\00	\00\00	\00\00	\00\00	\00\00	\00\00	\00\00
N23:50	\00\00	\00\00	\00\00	\00\00	\00\00	\00\00	\00\00	\00\00	\00\00	\00\00	\00\00	\00\00
N23:60	\00\00	\00\00	\00\00	\00\00	\00\00	\00\00	\00\00	\00\00	\00\00	\00\00	\00\00	\00\00
N23:70	\00\00	\00\00	\00\00	\00\00	\00\00	\00\00	\00\00	\00\00	\00\00	\00\00	\00\00	\00\00
N23:80	\00\00	\00\00	\00\00	\00\00	\00\00	\00\00	\00\00	\00\00	\00\00	\00\00	\00\00	\00\00
N23:90	\00\00	\00\00	\00\00	\00\00	\00\00	\00\00	\00\00	\00\00	\00\00	\00\00	\00\00	\00\00
N23:100	\00\00	\00\00	\00\00	\00\00	\00\00	\00\00	\00\00	\00\00	\00\00	\00\00	\00\00	\00\00
N23:110	\00\00	\00\00	\00\00	\00\00	\00\00	\00\00	\00\00	\00\00	\00\00	\00\00	\00\00	\00\00
N23:120	\00\00	\00\00	\00\00	\00\00	\00\00	\00\00	\00\00	\00\00	\00\00	\00\00	\00\00	\00\00
N23:130	\00\00	\00\00	\00\00	\00\00	\00\00	\00\00	\00\00	\00\00	\00\00	\00\00	\00\00	\00\00
N23:140	\00\00	\00\00	\00\00	\00\00	\00\00	\00\00	\00\00	\00\00	\00\00	\00\00	\00\00	\00\00
N23:150	\00\00	\00\00	\00\00	\00\00	\00\00	\00\00	\00\00	\00\00	\00\00	\00\00	\00\00	\00\00

Data Table File N22 Monitor

Below is a partial listing of the Data Table File N22. The table shows N22:1 bit 7 as the DeviceNet status bit which toggles between 0 and 1 to indicate ‘send next message’.

1771-SDN to AdaptaScan Interface

Data Table	Processor File: MASTER.ACH	Data Table File N22
Address	Data (Radix=BINARY)	
N22:0	0 0 0 0 0 0 0 0 0 0 0 0 0 0 0 0	
N22:1	0 0 0 0 0 0 0 0 1 0 0 0 0 0 0 0	
N22:2	0 0 0 0 0 0 0 0 0 0 0 0 0 0 0 0	
N22:3	0 0 0 0 0 0 0 0 0 0 0 0 0 0 0 0	

Configuring the DeviceNet Scanner

This section describes how to configure the 1771-SDN Scanner using the DeviceNet Manager software.

Before configuring the 1771-SDN Scanner, you **must** wire the DeviceNet network and apply DeviceNet Address of 3 to the AdaptaScan Bar Code Reader. See page 11-15.

To configure the 1771-SDN DeviceNet Scanner:

1. Double-click the DeviceNet Manager icon.
2. Create a new project with the network name Network 1.
3. Click the Build Online button to create a DeviceNet network. The network should have the following nodes:
 - Node 1 – 1771-SDN Scanner Module
 - Node 3 – 2755-SNx AdaptaScan Bar Code Reader
 - Node 62 – 1787-MGR DeviceNet Manager

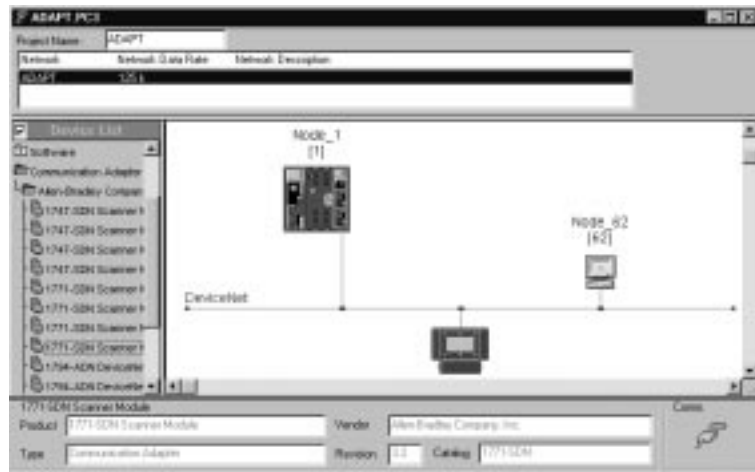

- Double-click the 1771-SDN Scanner Module to open the 1771-SDN Module and Channel Configuration dialog.

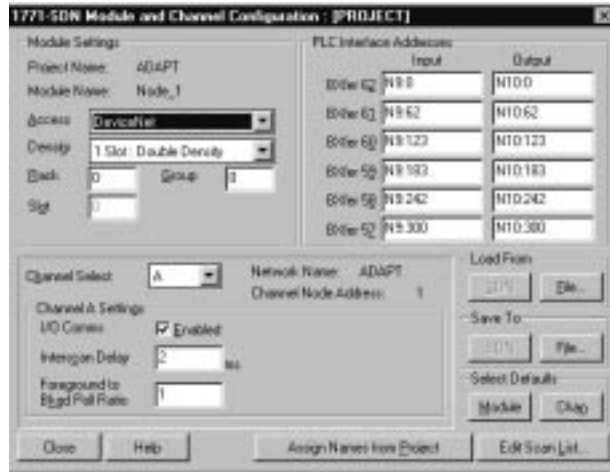

- Set the following PLC Interface Addresses. All other default values can remain the same.

	Input	Output
BXfer 62	N23:0	N22:0

The PLC ladder logic uses these addresses in the Block Transfer Read (N23:0) and Block Transfer Write (N22:0) instructions. The SDN scanner maps data from the AdaptaScan Reader to its 62 word file. This selection maps data to the N23 file in the PLC. The BTW instruction writes data from the N22 file to the 62 word file in the SDN scanner.

If you are using an AdaptaScan with v7.0 (or lower) firmware on a network with 2 or more nodes, change the InterScan Delay parameter to 20 ms. This will allow the AdaptaScan more CPU time to process bar code data instead of responding to DeviceNet polls.

Note: Version 8.0 of the AdaptaScan Offline Programming Software and firmware minimizes DeviceNet polling interruption of scanning.

6. Click the Edit Scan List button to open the Scan List Editor.

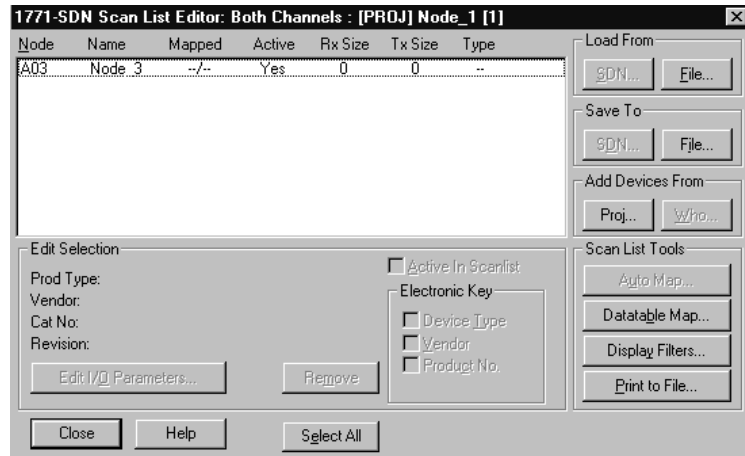

7. Select **A03** and click the Edit I/O Parameters button.
8. Edit the following parameters in the Edit Device I/O Parameters dialog:
- Under I/O Type, select the Polled check box.
 - In the Poll Rx Size box, type **8** (Bytes)
 - In the Poll Tx Size box, type **1** (Bytes)
 - From the Poll Rate list box, select **Every Scan**.

The dialog should look like this:



9. Click OK to return to the Scan List Editor dialog.

Node 3 (AdaptaScan) is enabled and will be polled by the SDN scanner. The SDN scanner will expect 8 bytes of data (4 characters + 4 bytes of overhead) and will transmit 1 byte of data back to the module (BTW N22:1).

10. Click the Datable Map button to open the Datable Map dialog.

The dialog shows the data table map of the N23 file. The data from the AdaptaScan Reader is mapped to the PLC (BTR N23).

- Word 0 is reserved
- 4 words (8 bytes) are mapped for the incoming string from the AdaptaScan Reader.
- Bit 15 is the 'new message being sent' bit.



11. Click the Data Entry button.
12. Change Map Data From to **Poll Message**.
13. Change Map Data To **Block Transfer 62**.
14. Change N23:0 to **1**.
15. Change No. Bits to **64**.
16. Click Apply Segment.

17. Next to Data Map, select **Output** to view the output file (N22).

The dialog shows the data table map for the N22 file. The data map represents data sent to the AdaptaScan Reader through the SDN Scanner (BTW N22)

- Word 1 writes one byte of data to the module.
- Bit 7 of word 1 is the 'send next message' bit.

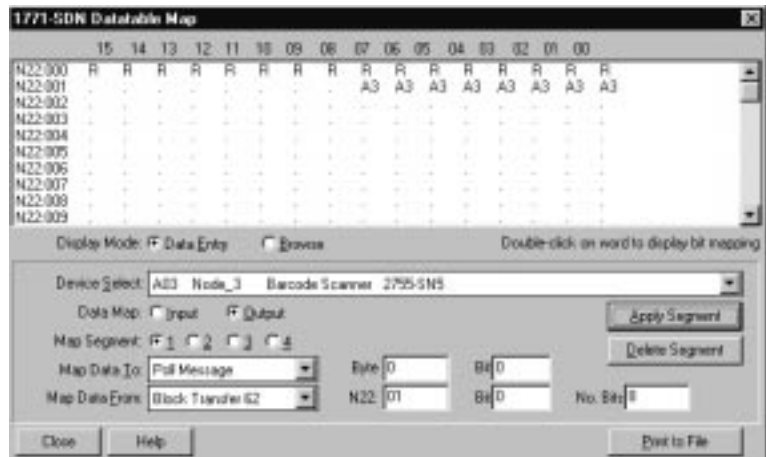

18. Change Map Data From to **Poll Message**.

19. Change Map Data To **Block Transfer 62**.

20. Change N22:0 to **1**.

21. Change No. Bits to **8**.

22. Click Apply Segment button.

23. Click Close to return the Scan List Editor dialog.

24. Click the Save To File button and then the Save to SDN button to download the scan list the 1771-SDN Scanner.

Important: Before clicking the Save to SDN button, the SDN Scanner must be in Idle Mode. Set bit 0 of word 0 in the BTW N22 file to 0 (N22:0/0=0). Another way to place the SDN Scanner in Idle Mode is to put the PLC into Program Mode.

Configuring the Reader

This section shows how to configure the AdaptaScan Bar Code Reader using AdaptaScan Software (Catalog No. 2755-ASN).

The procedures in this section show how to:

- scan/decode 4 character, Interleaved 2 of 5 labels
- define a DeviceNet address
- configure the scanner
- configure the decoder trigger
- configure the format of messages and the message destination

Create a New Project

Create a new project named PLC DeviceNet for one AdaptaScan Bar Code Reader (Bar Code Reader 1).

1. Choose New from the Project menu to create a new project.
2. Click the New button to add a bar code reader (Bar Code Reader 1) to the project.

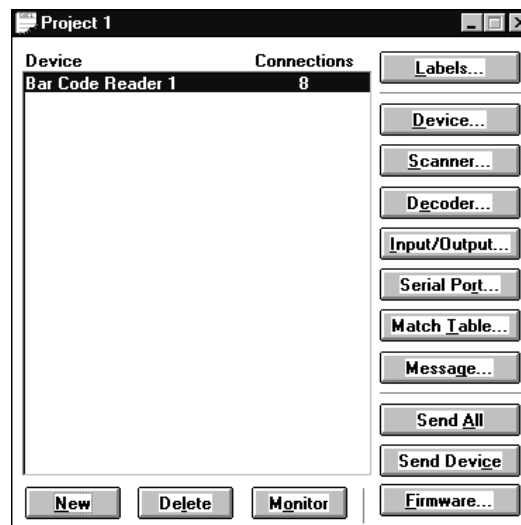

3. Choose Edit from the Project menu to rename the project **PLC DeviceNet**.

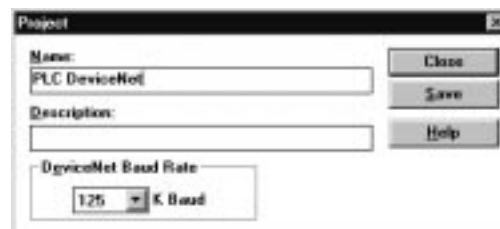

If you need to change the baud rate, proceed to the next section. If you do not need to change the baud rate, proceed to step 4.

4. Click Save to save the project under the new name and then Close to return to the Project dialog.

Change the Baud Rate

If you need to change the baud rate:

1. Click on the K Baud button and select the desired baud rate.

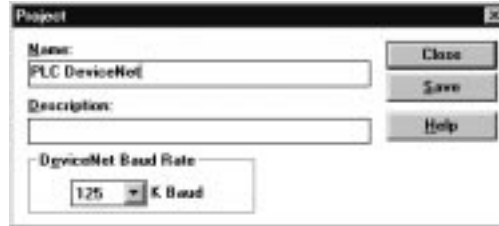

2. Click Save and Close to return to the Project dialog.
3. Click the Device button.
4. Click Apply if the desired baud rate is shown.
5. Click Save and Close to return to the Project dialog.
6. Click the Send Device button.

Define the Bar Code Label

1. Click the Labels button to open the Bar Code Labels dialog.
2. Click the New button to define a label.

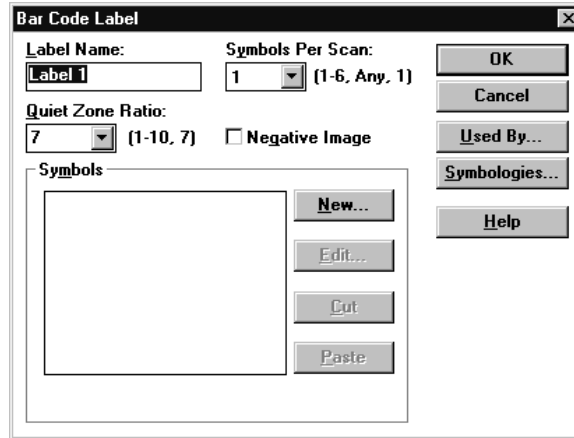

3. Click the New button to define a symbol for the label.

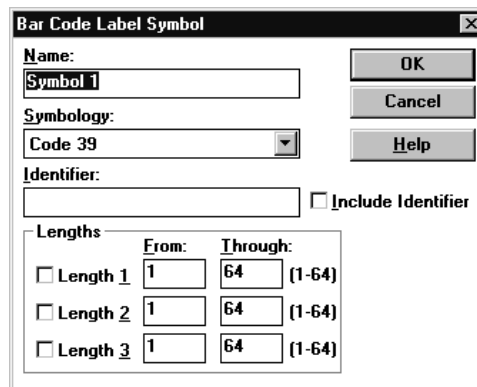

4. From the Symbology list, select **Interleaved 2 of 5**.
5. Under Lengths, select the **Length 1** check box and then type **4** in the Through box. This indicates a 4 character length for Interleaved 2 of 5 labels.
6. Click OK until you return to the Bar Code Labels dialog.
7. Click Save and then Close to return to the Project dialog.

Define the DeviceNet Address

1. Click the Device button on the Project dialog.



2. Set the DeviceNet address to 3.
3. Connect the 2755-NC43 or -NC48 Configuration Cable to the reader.
4. Click the Apply button.
5. Click Save and Close to return to the Project dialog.

Configure the Scanner

1. Click the Scanner button on the Project dialog to open the Scanner dialog.

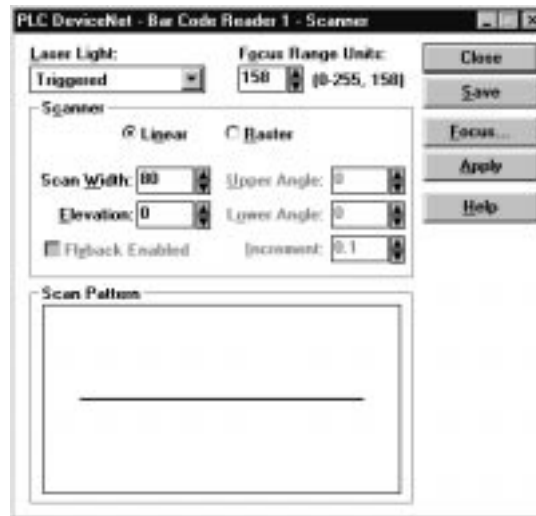

2. Configure the scan pattern and use the Focus procedure for optimum scanner focus.
3. Click the Close button and return to the Project dialog.

Configure the Decoder Trigger

To test the application, use the Timer to trigger the reader's decoder.

1. Click the Decoder button from the main Project dialog.
2. Under Triggered By, select **Timer** from the Input list.



3. Click the Save button.
4. Click the Close button and return to the main Project dialog.

Create a Message

This section defines the content of messages sent to the 1771-SDN Scanner.

1. Click the Message button from the main Project dialog.
2. Under Triggered By, check the Enable check box.

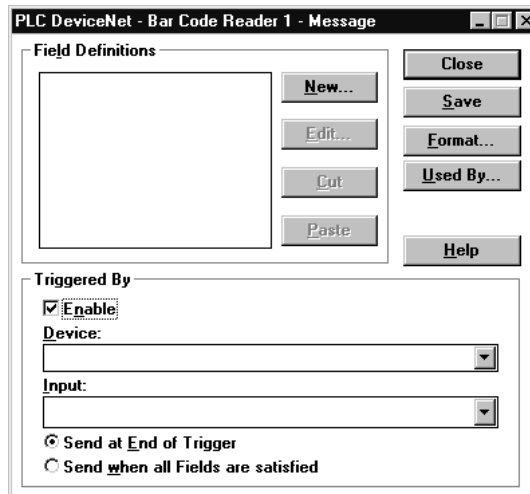

3. Under Device, select **Bar Code Reader 1**.
4. Under Input, select **[Decoder]**.

- Click the New button to create a message field.

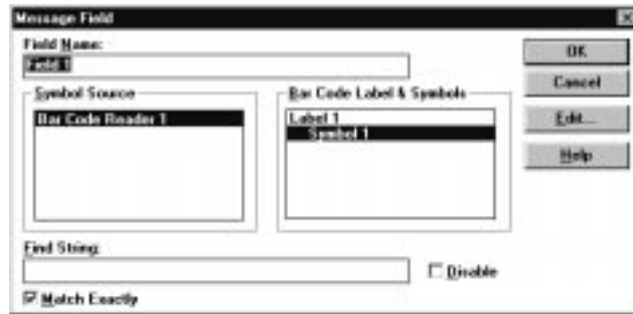

- Under Symbol Source, select **Bar Code Reader 1**.
- Under Bar Code Label & Symbols, select **Symbol 1**.
- Check (enable) the Match Exactly check box.
- Click the Edit button to open the Message Field Edit dialog.

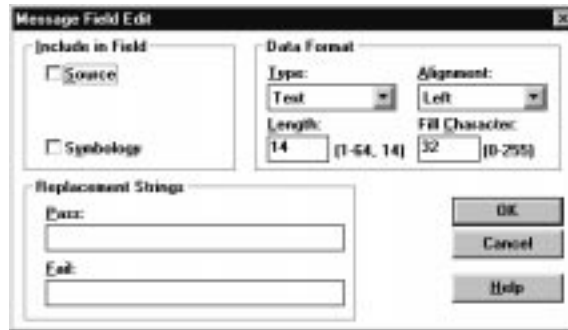

- Under Replacement Strings, type **nr** in the Fail: field.
Bar code data is sent to the 1771-SDN Scanner on a valid read; the Fail string send the characters nr when a no read occurs.
- Under Data Format, type **4** in the Length box.
Important: The Length must match the number of characters in the bar code symbol. This application uses 4 character, Interleaved 2 of 5 symbols.
- Click OK to return to the Message Field dialog.
- Click OK to return to the Message dialog.

Define the Message Format

The section defines the format and destination of the messages sent from the reader.

1. Click the Format button from the Message dialog.



2. Under Message Destination, select **DeviceNet**.
3. Accept the defaults for all other parameters.
4. Click OK to return to the Message dialog.
5. Click Save and then Close to return to the main Project dialog.

Sending the Configuration to the Reader

From the main Project dialog, click the Send Device button to download the configuration to the bar code reader.

Use the Monitor dialog to verify the decoding of bar code labels.

Running the Application

If the:

- AdaptaScan Reader is configured correctly
- 1771-SDN Scanner is configured correctly
- ladder program is entered as shown in this application

you will see bar code data or 'nr' in the PLC BTR (N23) file. Remember that all data is byte swapped.

Troubleshooting Your Module

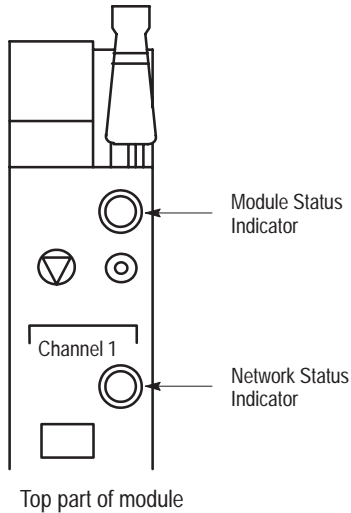

The bicolor (green/red) module status indicator displays device status. The LED indicates whether the device has power and is functioning properly.

If the Module LED is	this indicates	Take this action
Off	there is no power applied to the module.	Apply power.
Solid green	the module is operating in normal condition.	None
Flashing green	the module is not configured.	Configure the module.
Flashing red	there is invalid configuration.	Check configuration setup and verify dip switch settings.
Solid red	the module has an unrecoverable fault.	Replace the module.

Channels 1 and 2 each have a bicolor (green/red) network status indicator. The following table provides troubleshooting information about the Channel 1 and 2 communication links.

If the NET indicator is	this indicates	Take this action
Off	the channel is disabled for DeviceNet communication.	Power-up the module, provide network power to channel, and be sure channel is enabled in both the module configuration table and module command word.
Flashing green	the channel is enabled but no communication is occurring.	Configure scan list table for channel to add devices.
Solid green	all slave devices in the scan list table are communicating normally with the module.	None.
Solid red	the module may be defective.	Reset module. If failures continue, replace module.
Flashing red	at least one of the slave devices in the module's scan list table has failed to communicate with the module. The network has faulted.	Examine the failed device and the scan list table for accuracy.

Top part of module

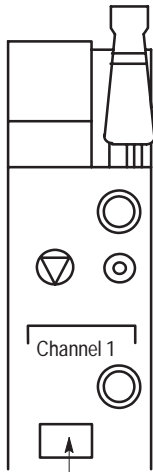

Node Address /
Status Indicator

Your 1771-SDN Scanner Module has a node address/status indicator that uses numeric displays to indicate diagnostic information about your module. The display flashes at approximately 1 second intervals, depending on network traffic. The following table summarizes the meanings of the numeric codes.

Numeric Code	Indicates	Take this action
Network Address Displays 0 - 63	normal operation. The numeric display matches the scanner's node address on the DeviceNet network.	None.
70	module failed Duplicate Node Address check.	Change the module channel address to another available one. The node address you selected is already in use on that channel.
71	illegal data in scan list table (node number alternately flashes).	Reconfigure the scan list table and remove any illegal data.
72	slave device stopped communicating (node number alternately flashes).	Inspect the field devices and verify connections.
73	device key parameters do not match scan list table entry (node number alternately flashes).	Enter a matching scan list device ID.
74	data overrun on port detected.	Modify your configuration and check for invalid data. Check network communication traffic.
75	no network traffic has been detected.	Verify connections.
76	no direct network traffic for module detected.	None. The module hears other network communication.
77	data size expected does not match scan lists entry (node number alternately flashes).	Reconfigure your module for the correct transmit and receive data sizes
78	slave device in scan list table does not exist (node number alternately flashes).	Add the device to the network, or delete the scan list entry for that device.
79	module has failed to transmit a message.	Make sure that your module is connected to a valid network. Check for disconnected cables.
80	module is in IDLE mode.	Place PLC-5 in Run mode.
81	module is in FAULT mode.	Check ladder program for cause of fault bits.
82	error detected in sequence of fragmented I/O messages from device (node number alternately flashes).	Check scan list table entry for slave device to make sure that input and output data lengths are correct. Check slave device configuration.
83	slave device is returning error responses when module attempts to communicate with it (node number alternately flashes).	Check accuracy of scan list table entry. Check slave device configuration. Slave device may be in another master's scan list. Reboot slave device.
84	module is initializing the DeviceNet channel.	None. This code clears itself once module attempts to initialize all slave devices on the channel.
85	data size returned is bigger than 255 bytes (node number alternately flashes).	Configure device for smaller data size.
86	device is producing idle state data while the scanner is in Run Mode.	Check device configuration/slave node status.
88	this is not an error. At power-up and reset, the module displays all 14 segments of the node address and status display LEDs.	None.

Table continued on the next page.

Numeric Code	Indicates	Take this action
90	user has disabled communication port	reconfigure your module. Check the disable bit in the Module Command Register.
91	bus-off condition detected on comm port. module is detecting communication errors.	Check DeviceNet connections and physical media integrity. Check system for failed slave devices or other possible sources of network interference.
92	no network power detected on comm port.	Provide network power. Make sure that module drop cable is providing network power to module comm port.
95	application FLASH update in progress.	None. Do not disconnect the module while application FLASH is in progress. You will lose any existing data in the module's memory.
97	module halted by user command.	Check ladder program for cause of fault bits.
98	Unrecoverable firmware failure.	Service or replace your module.
99	Unrecoverable hardware failure.	Service or replace your module.

Communicating with a PLC-5 Processor on a DeviceNet Network using Explicit Messaging

Overview

This application describes how to connect and configure an AdaptaScan Bar Code Reader to communicate with a PLC-5 processor over a DeviceNet network in a master/slave mode using explicit messaging. A 4 character Interleaved 2 of 5 bar code symbol is used in this application.

The DeviceNet network has the following nodes:

- AdaptaScan Bar Code Reader on node 3
- 1771-SDN DeviceNet Scanner on node 1
- Computer running DeviceNet Manager Software on node 62

The DeviceNet terminal block in the reader's wiring base connects the AdaptaScan Reader to the DeviceNet network. The wiring base has two DeviceNet terminal blocks; one for upstream connection and one for downstream connection.

Hardware Requirements

The hardware items required for this application are:

- 2755-SN3, -SN5 or -SN8 AdaptaScan Bar Code Reader
- 2755-NB40 or -NB41 Wiring Base
- 2755-PW46 or -PW47 Power Supply
- 2755-NC43 or -NC48 Configuration Cable
- 1771-SDN Scanner Module (v3.04 firmware or later)
- 1770-KFD DeviceNet RS-232 Interface
- DeviceNet trunk cable
- 1771 I/O chassis
- PLC-5 processor
- Computer running Windows 3.1 (or later) or Windows 95
- 9-to-25 Pin Adapter (for Computer with 25-pin COM port)

Software Requirements

The software requirements for this application are:

- 2755-ASN AdaptaScan Offline Programming Software (v8.0 or later)
- 6200 Series Programming Software
- 1787-MGR DeviceNet Manager Software (v3.0 or later)

Related Publications

Related publications include:

Publication	Description
2755-837	AdaptaScan Bar Code Readers User Manual
2755-838	AdaptaScan Software User Manual
1787-6.5.3	DeviceNet Manager Software Manual
1771-6.5.118	DeviceNet Scanner Configuration Manual

In addition, you may want to refer to the PLC-5 Hardware and Software User Manuals.

Connecting to the DeviceNet Network

The following illustration shows the three nodes of the DeviceNet master/slave network.

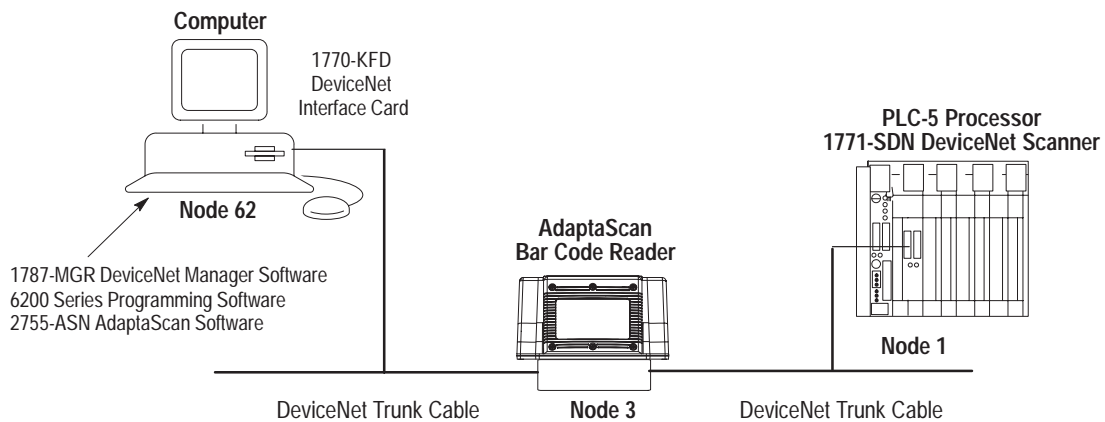

Connecting a Power Supply to the Reader

The following illustration shows how to connect a 2755-PW46 or -PW47 power supply to a single bar code reader.

Use a shielded cable (Belden 9316 recommended) to make the connections. Connect the shield to the ground screw on the reader's wiring base.

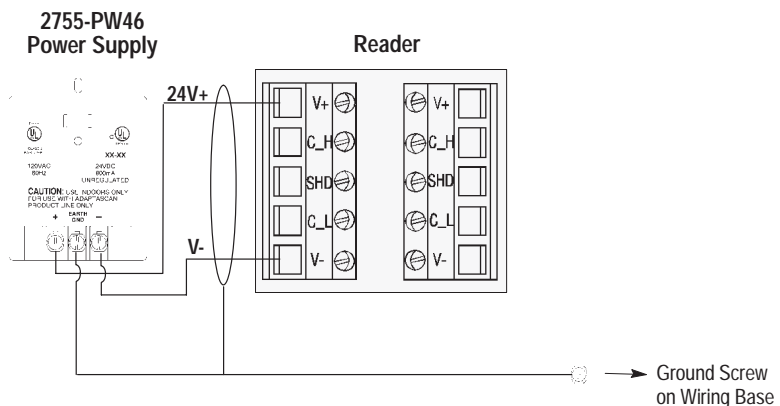

PLC Ladder Logic

This section provides the PLC-5 ladder logic program and data monitor results. The ladder logic uses:

- File N23 as the BTR file
- File N22 as the BTW file

The data table shows file N23 after the AdaptaScan Reader successfully reads and transfers data '0300' (from a 4 character, Interleaved 2 of 5 symbol) to the PLC-5 data table.

File	Location	Description
N23	Word 0	Status word for SDN Scanner
	Word 1 Bit 15	'New Message Being Sent' bit from AdaptaScan Reader
N22	Word 0	Status word
	Word 0 Bit 0	1=SDN Scanner in run mode 0=SDN Scanner in idle mode Idle mode is used to write the DeviceNet configuration to the SDN Scanner.
	Word 1 Bit 7	'Send Message' bit to AdaptaScan Reader

Message Addressing

Message Data is formatted the same as messages sent through the serial port. When setting up the DeviceNet scanner for addressing message data, use the following table.

Description	Word #	Byte # ^{①②}
Number of Characters (LSB)	2	2
Number of Characters (MSB)		3
First Message Character (Beginning of Message)	3	4
Other Message Characters from left to right		5 →
Last Message Character (End of Message)		3+N where N is the number of characters in the message.

^① Bytes #0 and #1 (word 1) are reserved for Discrete I/O.

^② Poll Rx Size = 4 + (# of Characters in string).

Message data is addressed and sent to other DeviceNet devices through a DeviceNet scanner (Catalog No. 1771-SDN or 1747-SDN). To configure the scanner, you will need to provide the size of the message data, the beginning byte and bit number of the message and the destination of the message data.

Message Flow Control

DeviceNet Input #8 and Output #16 control the transmission of bar code messages when using DeviceNet master-slave. Message flow control (handshaking) lets the controller know that data is available and that the reader does not send out messages faster than they can be received. Your controller logic program must transfer the message data and set the DeviceNet Input #8 (Send Next Data) for message flow control.

New Data

Is indicated by changing the state of DeviceNet Output #16 of the DeviceNet I/O. A change of state (0 to 1 or 1 to 0) indicates that a new message is being sent.

Send Next Data

Is indicated by changing the state of DeviceNet Input #8 of the DeviceNet I/O. A change of state (0 to 1 or 1 to 0) indicates that the controller is ready to receive the next message.

Flow Control Example

The following shows how DeviceNet Input #8 and Output #16 control the transmission of messages. Output #16 is changed by the reader and Input #8 is changed by the controller.

DeviceNet Scan Number	Message Data	DeviceNet Output #16	DeviceNet Input #8
1 - Poll	-		OFF (0)
1 - Response	No Message Sent	OFF (0)	
2 - Poll	-		ON (1)
2 - Response	Message 1 Sent	ON (1)	
3 - Poll	-		OFF (0)
3 - Response	Message 2 Sent	OFF (0)	

Note: The following ladder logic program is for reference only. Application specific interlocks may be necessary.

Rung 2:0

This rung is toggled via the control bits sent from the AdaptaScan. Bit 15 of word 1 is toggled when no data is being sent from adaptascan. It latches bit 7 if word 1 in our Block Transfer Write file. This tells the adaptascan to send the next message.



Rung 2:1

This rung block transfers our data from the 1771-SDN scanner card to the PLC address N23:0. Length is corresponding to the type of block transfer executed in the SDN scanner card. This is done via the DeviceNetManager software.

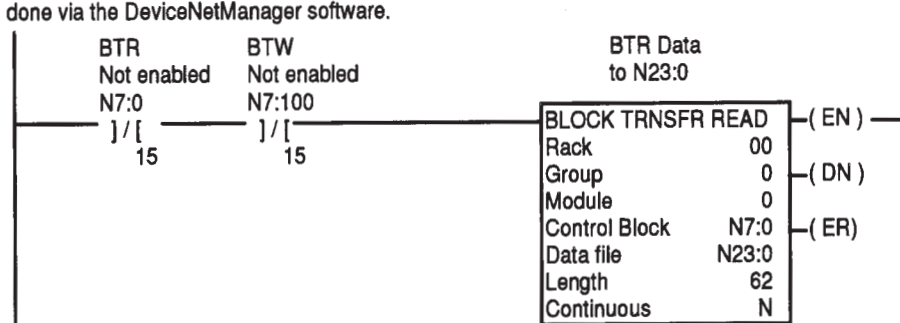

Rung 2:2

This rung executes a BTW from our N22 file. This sends the status of bit 7 to the scanner card to tell the adaptascan it can send its next message. Also very important: bit 0 of word 0 needs to be set to 1 in order to put the SDN scanner card in run mode.

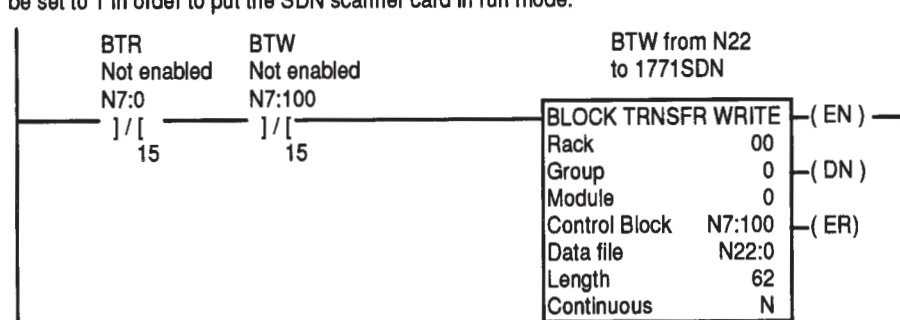

Rung 2:3

If a new message is being sent this rung unlatches our bit 7 in the BTW file telling the adaptascan the SDN module/PLC is busy processing a previous message

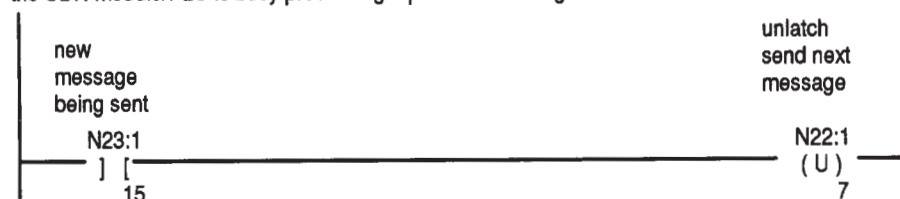

Rung 2:4

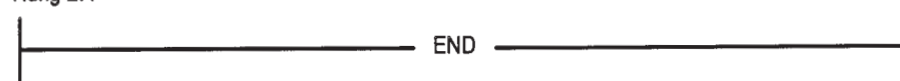

Note: If you are using channel B instead of channel A, bit 2 of word 0 needs to be set to 1.

Data Table File N23 Monitor

In Data Table File N23:

- N23:1 contains the DeviceNet status bits
- Bit 15 is the control bit from the AdaptaScan Reader which toggles between 0 and 1 to indicate a ‘new message being sent’
- N23:2 is the byte count (4) of the message sent from the reader
- N23:3 is the start of the data read 3000. Data is actually 0300. All data is byte swapped.

1771-SDN to AdaptaScan Interface

Data Table		Processor File :MASTER.ACH				Data Table File N23				
Address	Data (Radix = ASCII)									
N23:0	\00\00 \80\01 \00\04	3	0	0	0	\00\00	\00\00	\00\00	\00\00	\00\00
N23:10	\00\00 \00\00 \00\00	\00\00	\00\00	\00\00	\00\00	\00\00	\00\00	\00\00	\00\00	\00\00
N23:20	\00\00 \00\00 \00\00	\00\00	\00\00	\00\00	\00\00	\00\00	\00\00	\00\00	\00\00	\00\00
N23:30	\00\00 \00\00 \00\00	\00\00	\00\00	\00\00	\00\00	\00\00	\00\00	\00\00	\00\00	\00\00
N23:40	\00\00 \00\00 \00\00	\00\00	\00\00	\00\00	\00\00	\00\00	\00\00	\00\00	\00\00	\00\00
N23:50	\00\00 \00\00 \00\00	\00\00	\00\00	\00\00	\00\00	\00\00	\00\00	\00\00	\00\00	\00\00
N23:60	\00\00 \00\00 \00\00	\00\00	\00\00	\00\00	\00\00	\00\00	\00\00	\00\00	\00\00	\00\00
N23:70	\00\00 \00\00 \00\00	\00\00	\00\00	\00\00	\00\00	\00\00	\00\00	\00\00	\00\00	\00\00
N23:80	\00\00 \00\00 \00\00	\00\00	\00\00	\00\00	\00\00	\00\00	\00\00	\00\00	\00\00	\00\00
N23:90	\00\00 \00\00 \00\00	\00\00	\00\00	\00\00	\00\00	\00\00	\00\00	\00\00	\00\00	\00\00
N23:100	\00\00 \00\00 \00\00	\00\00	\00\00	\00\00	\00\00	\00\00	\00\00	\00\00	\00\00	\00\00
N23:110	\00\00 \00\00 \00\00	\00\00	\00\00	\00\00	\00\00	\00\00	\00\00	\00\00	\00\00	\00\00
N23:120	\00\00 \00\00 \00\00	\00\00	\00\00	\00\00	\00\00	\00\00	\00\00	\00\00	\00\00	\00\00
N23:130	\00\00 \00\00 \00\00	\00\00	\00\00	\00\00	\00\00	\00\00	\00\00	\00\00	\00\00	\00\00
N23:140	\00\00 \00\00 \00\00	\00\00	\00\00	\00\00	\00\00	\00\00	\00\00	\00\00	\00\00	\00\00
N23:150	\00\00 \00\00 \00\00	\00\00	\00\00	\00\00	\00\00	\00\00	\00\00	\00\00	\00\00	\00\00

Data Table File N22 Monitor

Below is a partial listing of the Data Table File N22. The table shows N22:1 bit 7 as the DeviceNet status bit which toggles between 0 and 1 to indicate ‘send next message’.

1771-SDN to AdaptaScan Interface

Data Table	Processor File: MASTER.ACH	Data Table File N22
Address	Data (Radix=BINARY)	
N22:0	0000000000000000	
N22:1	0000000010000000	
N22:2	0000000000000000	
N22:3	0000000000000000	

Configuring the DeviceNet Scanner

This section describes how to configure the 1771-SDN Scanner using the DeviceNet Manager software.

Before configuring the 1771-SDN Scanner, you **must** wire the DeviceNet network and apply DeviceNet Address of 3 to the AdaptaScan Bar Code Reader. See page 12-15.

To configure the 1771-SDN DeviceNet Scanner:

1. Double-click the DeviceNet Manager icon.
2. Create a new project with the network name Network 1.
3. Click the Build Online button to create a DeviceNet network. The network should have the following nodes:
 - Node 1 – 1771-SDN Scanner Module
 - Node 3 – 2755-SNx AdaptaScan Bar Code Reader
 - Node 62 – 1787-MGR DeviceNet Manager

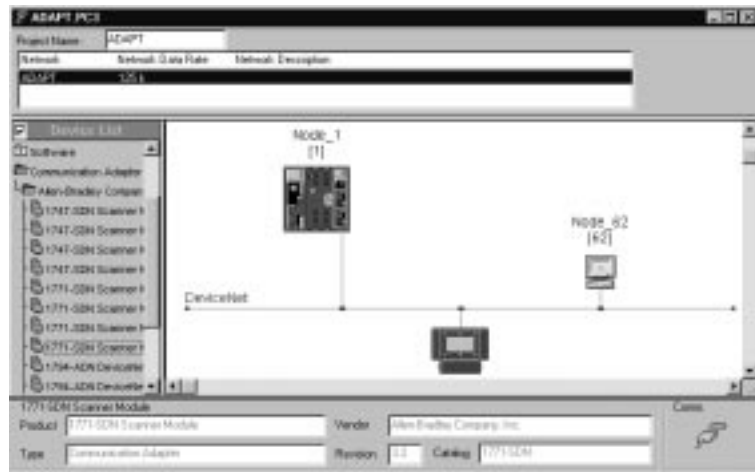

- Double-click the 1771-SDN Scanner Module to open the 1771-SDN Module and Channel Configuration dialog.

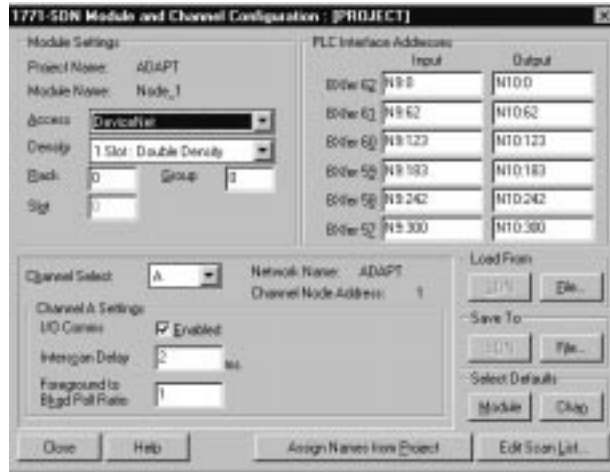

- Set the following PLC Interface Addresses. All other default values can remain the same.

	Input	Output
BXfer 62	N23:0	N22:0

The PLC ladder logic uses these addresses in the Block Transfer Read (N23:0) and Block Transfer Write (N22:0) instructions. The SDN scanner maps data from the AdaptaScan Reader to its 62 word file. This selection maps data to the N23 file in the PLC. The BTW instruction writes data from the N22 file to the 62 word file in the SDN scanner.

If you are using an AdaptaScan with v7.0 firmware on a network with 2 or more nodes, change the InterScan Delay parameter to 20 ms. This will allow the AdaptaScan more CPU time to process bar code data instead of responding to DeviceNet polls.

Note: Version 8.0 of the AdaptaScan Offline Programming Software and firmware minimizes DeviceNet polling interruption of scanning.

- Click the Edit Scan List button to open the Scan List Editor.

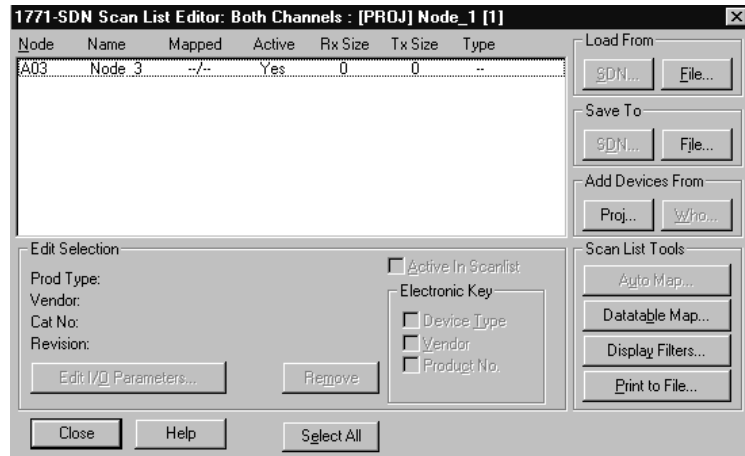

- Select **A03** and click the Edit I/O Parameters button.
- Edit the following parameters in the Edit Device I/O Parameters dialog:
 - Under I/O Type, select the Polled check box.
 - In the Poll Rx Size box, type **8** (Bytes)
 - In the Poll Tx Size box, type **1** (Bytes)
 - From the Poll Rate list box, select **Every Scan**.

The dialog should look like this:



- Click OK to return to the Scan List Editor dialog.

Node 3 (AdaptaScan) is enabled and will be polled by the SDN scanner. The SDN scanner will expect 8 bytes of data (4 characters + 4 bytes of overhead) and will transmit 1 byte of data back to the module (BTW N22:1).

10. Click the Datable Map button to open the Datable Map dialog.

The dialog shows the data table map of the N23 file. The data from the AdaptaScan Reader is mapped to the PLC (BTR N23).

- Word 0 is reserved
- 4 words (8 bytes) are mapped for the incoming string from the AdaptaScan Reader.
- Bit 15 is the 'new message being sent' bit.



11. Click the Data Entry button.
12. Change Map Data From to **Poll Message**.
13. Change Map Data To **Block Transfer 62**.
14. Change N23:0 to **1**.
15. Change No. Bits to **64**.
16. Click Apply Segment.

17. Next to Data Map, select **Output** to view the output file (N22).

The dialog shows the data table map for the N22 file. The data map represents data sent to the AdaptaScan Reader through the SDN Scanner (BTW N22)

- Word 1 writes one byte of data to the module.
- Bit 7 of word 1 is the 'send next message' bit.

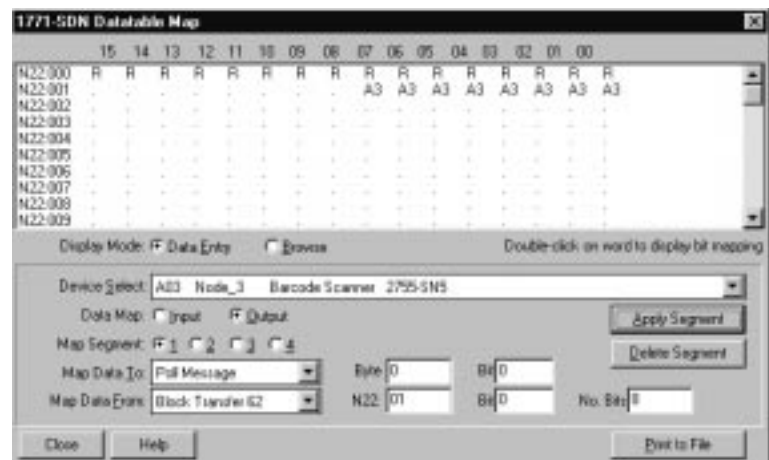

18. Change Map Data From to **Poll Message**.

19. Change Map Data To **Block Transfer 62**.

20. Change N22:0 to **1**.

21. Change No. Bits to **8**.

22. Click Apply Segment button.

23. Click Close to return the Scan List Editor dialog.

24. Click the Save To File button and then the Save to SDN button to download the scan list the 1771-SDN Scanner.

Important: Before clicking the Save to SDN button, the SDN Scanner must be in Idle Mode. Set bit 0 of word 0 in the BTW N22 file to 0 (N22:0/0=0). Another way to place the SDN Scanner in Idle Mode is to put the PLC into Program Mode.

Configuring the Reader

This section shows how to configure the AdaptaScan Bar Code Reader using AdaptaScan Software (Catalog No. 2755-ASN).

The procedures in this section show how to:

- scan/decode 4 character, Interleaved 2 of 5 labels
- define a DeviceNet address
- configure the scanner
- configure the decoder trigger
- configure the format of messages and the message destination

Create a New Project

Create a new project named PLC DeviceNet Master/Slave for one AdaptaScan Bar Code Reader (Bar Code Reader 1).

1. Choose New from the Project menu to create a new project.
2. Click the New button to add a bar code reader (Bar Code Reader 1) to the project.

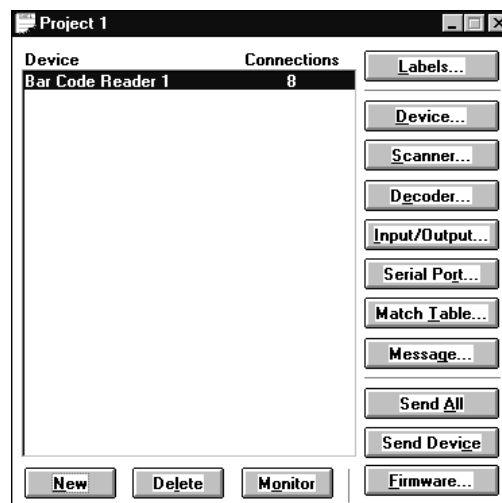

3. Choose Edit from the Project menu to rename the project **PLC DeviceNet Master/Slave**.

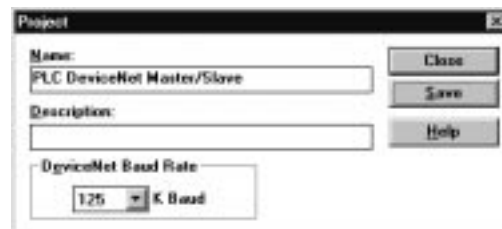

If you need to change the baud rate, proceed to the next section.
If you do not need to change the baud rate, proceed to step 4.

4. Click Save to save the project under the new name and then Close to return to the Project dialog.

Change the Baud Rate

If you need to change the baud rate:

1. Click on the K Baud button and select the desired baud rate.



2. Click Save and Close to return to the Project dialog.
3. Click the Device button.
4. Click Apply if the desired baud rate is shown.
5. Click Save and Close to return to the Project dialog.
6. Click the Send Device button.

Define the Bar Code Label

1. Click the Labels button to open the Bar Code Labels dialog.
2. Click the New button to define a label.

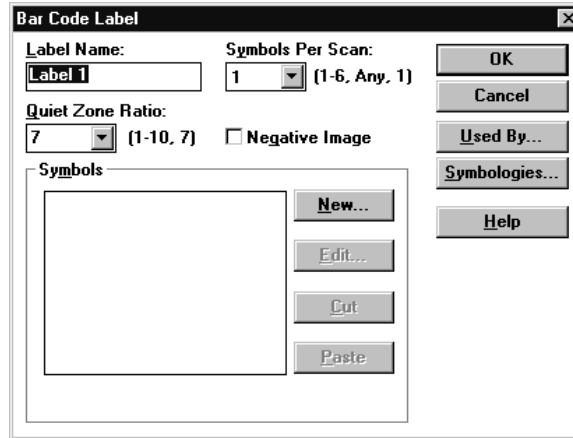

3. Click the New button to define a symbol for the label.

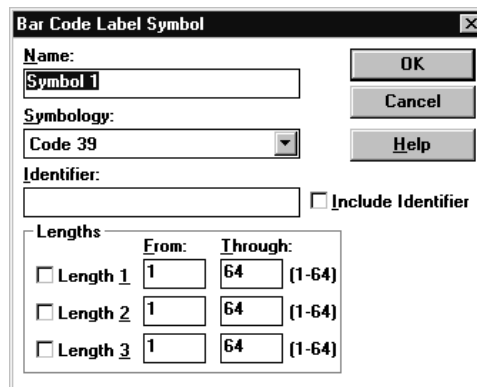

4. From the Symbology list, select **Interleaved 2 of 5**.
5. Under Lengths, select the **Length 1** check box and then type **4** in the Through box. This indicates a 4 character length for Interleaved 2 of 5 labels.
6. Click OK until you return to the Bar Code Labels dialog.
7. Click Save and then Close to return to the Project dialog.

Define the DeviceNet Address

1. Click the Device button on the Project dialog.



2. Set the DeviceNet address to 3.
3. Connect the 2755-NC43 or -NC48 Configuration Cable to the reader.
4. Click the Apply button.
5. Click Save and Close to return to the Project dialog.

Configure the Scanner

1. Click the Scanner button on the Project dialog to open the Scanner dialog.



2. Configure the scan pattern and use the Focus procedure for optimum scanner focus.
3. Click the Close button and return to the Project dialog.

Configure the Decoder Trigger

To test the application, use the Timer to trigger the reader's decoder.

1. Click the Decoder button from the main Project dialog.
2. Under Triggered By, select **Timer** from the Input list.



3. Click the Save button.
4. Click the Close button and return to the main Project dialog.

Create a Message

This section defines the content of messages sent to the 1771-SDN Scanner.

1. Click the Message button from the main Project dialog.
2. Under Triggered By, check the Enable check box.



3. Under Device, select **Bar Code Reader 1**.
4. Under Input, select **[Decoder]**.

- Click the New button to create a message field.

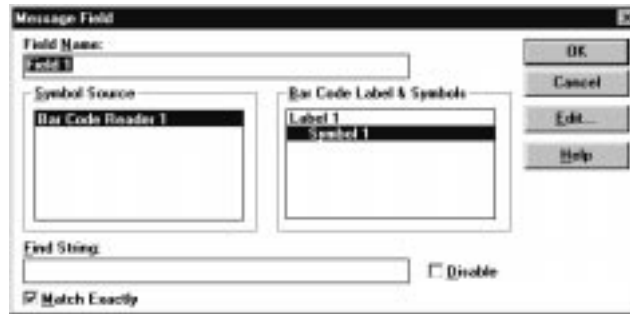

- Under Symbol Source, select **Bar Code Reader 1**.
- Under Bar Code Label & Symbols, select **Symbol 1**.
- Check (enable) the Match Exactly check box.
- Click the Edit button to open the Message Field Edit dialog.

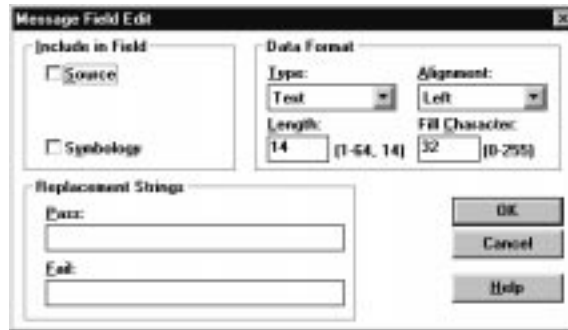

- Under Replacement Strings, type **nr** in the Fail: field.
Bar code data is sent to the 1771-SDN Scanner on a valid read; the Fail string sends the characters nr when a no read occurs.
- Under Data Format, type **4** in the Length box.
Important: The Length must match the number of characters in the bar code symbol. This application uses 4 character, Interleaved 2 of 5 symbols.
- Click OK to return to the Message Field dialog.
- Click OK to return to the Message dialog.

Define the Message Format

The section defines the format and destination of the messages sent from the reader.

1. Click the Format button from the Message dialog.



2. Under Message Destination, select **DeviceNet**.
3. Accept the defaults for all other parameters.
4. Click OK to return to the Message dialog.
5. Click Save and then Close to return to the main Project dialog.

Sending the Configuration to the Reader

From the main Project dialog, click the Send Device button to download the configuration to the bar code reader.

Use the Monitor dialog to verify the decoding of bar code labels.

Running the Application

If the:

- AdaptaScan Reader is configured correctly
- 1771-SDN Scanner is configured correctly
- ladder program is entered as shown in this application

you will see bar code data or 'nr' in the PLC BTR (N23) file. Remember that all data is byte swapped.

Explicit Message Program Control

Use the Explicit Message Program Control feature to configure device parameters on your DeviceNet network via the ladder logic program in the PLC-5 processor that is controlling these devices.

You can use Explicit Message Program Control only with devices that are slaves of your 1771-SDN Scanner Module. These slave devices must be mapped in the scanner module's scan list.

Use the Explicit Message Program Control feature to:

- transmit configuration data from your scanner module to its slave devices on your DeviceNet network
- receive status and diagnostics from these devices on your DeviceNet network
- make runtime adjustments to device parameters according to changing conditions detected by your processor

Explicit Message Program Control Feature

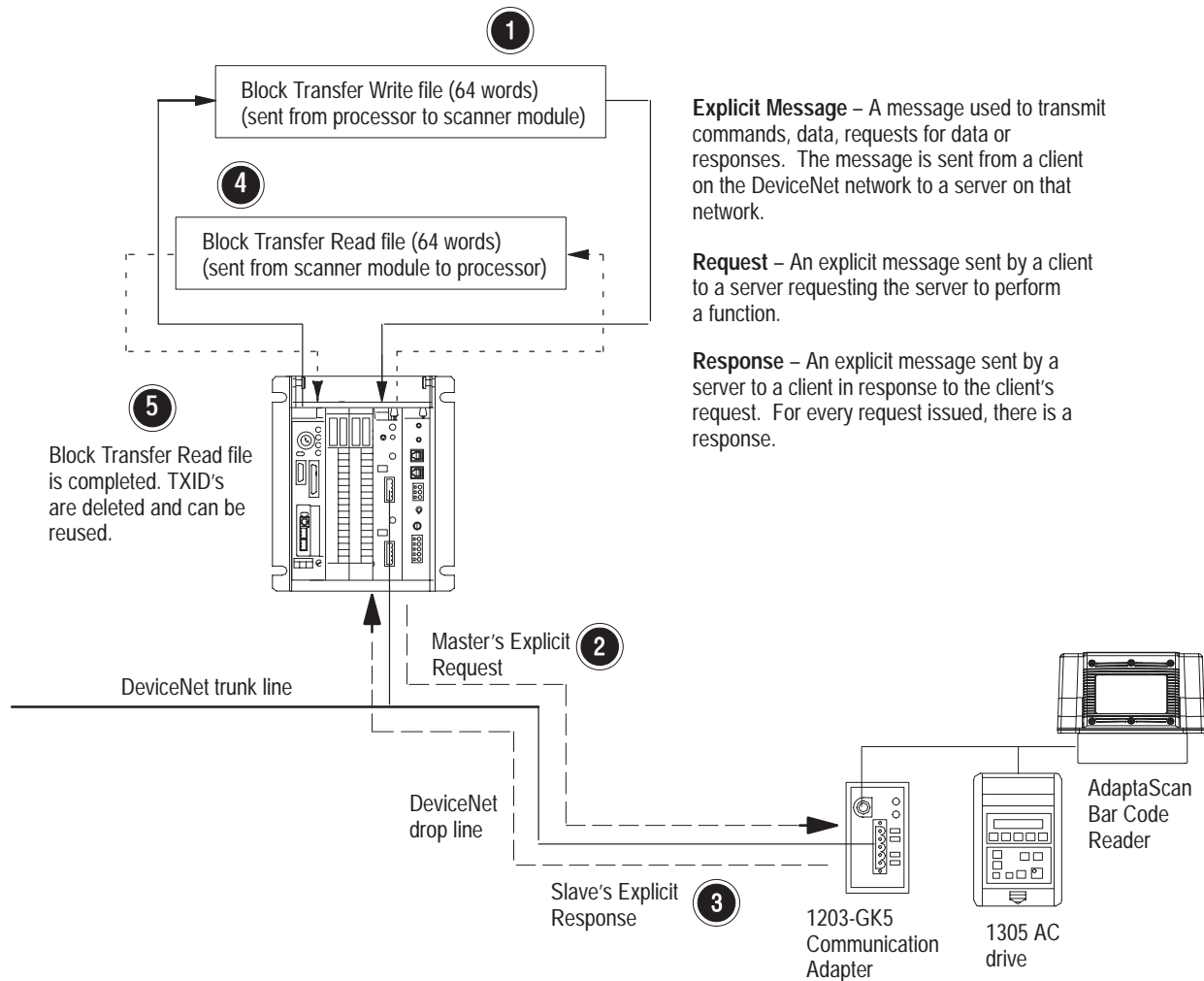

1. Format a Block Transfer Write file in the processor to send an Explicit Message Request to the scanner module (**download**).
2. The scanner module transmits the Explicit Message Request to the slave device over the DeviceNet network.
3. The slave device transmits the Explicit Message Response back to the scanner and is queued into a block transfer buffer.
4. The processor uses a Block Transfer Read file to retrieve the Explicit Message Response from the scanner's buffer (**upload**).
5. The Block Transfer Read file is completed. The transaction IDs are deleted and can be reused.

The scanner module requires a precisely-formatted block transfer read and write size of 64 words. The Explicit Message Control table in the scanner module is 64 words. The scanner module uses the block transfer size as an indicator that the content is a client/server request.

Formatting the Explicit Message Transaction Block

Ten 32-word transaction blocks within the scanner module are reserved for Explicit Message Program Control. The transaction blocks accommodate both the download of Explicit Message Requests and the upload of Explicit Message Responses.

The scanner module can accommodate one request or response for each transaction block and can transfer two blocks for each upload and download. You must format each transaction block as shown in the following figure.

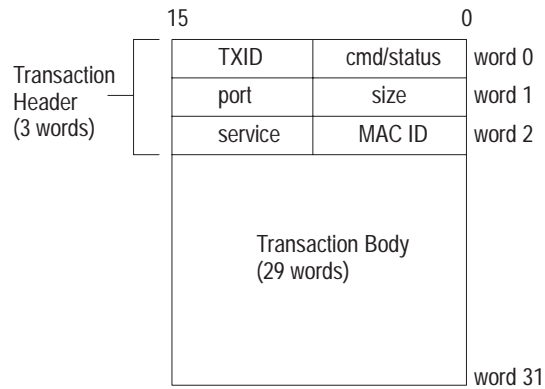

One word = two bytes = 16 bits

The transaction block is divided into two parts:

- **transaction header** – Contains information that identifies the transaction to the scanner and processor.
- **transaction body** – In a request, this contains the DeviceNet Class, Instance, Attribute and Service Data portion of the transaction. In a response, this contains only the response message.

Each of the data attributes in the transaction header are one byte in length:

- **command/status** – For each download, you assign a command code to instruct the scanner how to administer the request.

Command Code	Description
0	Ignore transaction block (block empty).
1	Execute this transaction block.
2	Get status of transaction TXID.
3	Reset all client/server transactions.
4	Delete transaction from response queue.
5-255	Reserved

For each upload, the status code provides the processor with status on the device and its response.

Status Code	Description
0	Ignore transaction block (block empty).
1	Transaction completed successfully
2	Transaction in progress (not ready)
3	Error – slave not in scan list
4	Error – slave offline
5	Error – DeviceNet port disabled/offline
6	Error – transaction TXID unknown
7	Unused
8	Error – Invalid command code
9	Error – Scanner out of buffers
10	Error – Other Client/server transaction in progress
11	Error – could not connect to slave device
12	Error – response data too large for block
13	Error – invalid port
14	Error – invalid size specified
15	Error – connection busy
16–255	Reserved

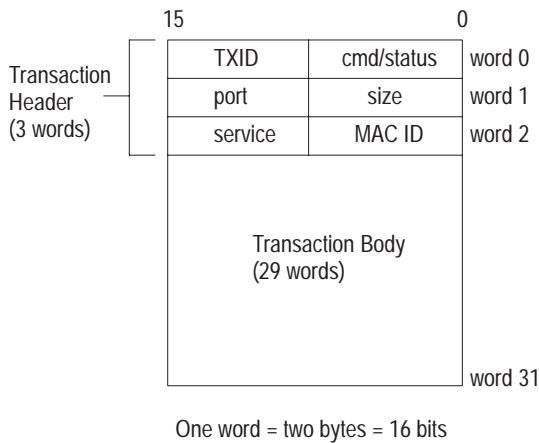

- TXID (transaction ID)** – When you create and download a request to the scanner, the processor’s ladder logic program assigns a TXID to the transaction. This is a one-byte integer in the range of 1 to 255. The scanner uses this value to track the transaction to completion, and returns the value with the response that matches the request downloaded by the processor. The ladder logic program monitors rollover and usage of TXID values.
- size** – The size of the transaction body in bytes. The transaction body can be as many as 29 words (58 bytes) in length. If the size exceeds 29 words, an error code will be returned.
- port** – The DeviceNet port where the transaction is routed. The port can be zero (Channel 1) or one (Channel 2).
- MAC ID (node address)** – The DeviceNet network address of the slave device where the transaction is sent. This value can range from 0 to 63. The port and MAC ID attributes coupled together identify the target slave device. The slave device must be listed in the scanner module’s scan list and be online for the Explicit Message transaction to be completed.
- service** – For each Explicit Message Request and Response, the service attribute contains the service request and response codes that match the corresponding request for the TXID.

The following figure describes the format and mapping of transaction blocks for request and response messages in the scanner module.

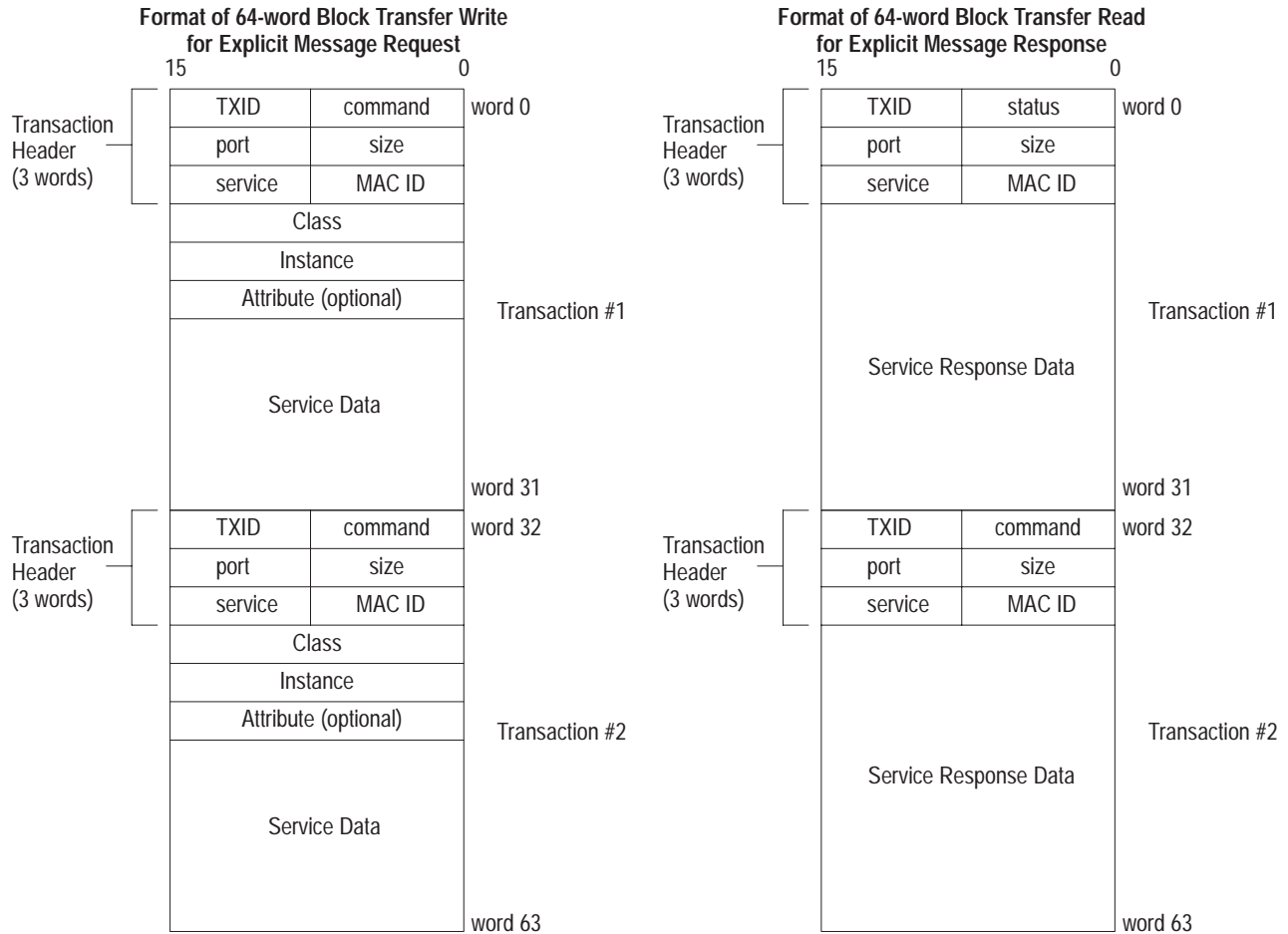

How the Processor and Scanner Module Manage Messages

Block transfer operations between the processor and the scanner always originate in the processor. The scanner module can only wait for the processor to download a transaction block to the module or request an upload of a transaction block from the module.

Once an Explicit Message Request transaction block is downloaded to the scanner module, a ladder logic program in the processor polls the scanner module for the transaction block containing the Explicit Message Response for that request. This is done by the processor with a Block Transfer Read on the scanner module. Depending on the network load, the scanner could take a few seconds to complete the request. When a response is loaded, bit 15 of the module status register is set to 1. The program may have to poll the scanner module a number of times before the scanner returns a Response Transaction Block.

The scanner module recognizes I/O data and control as higher priorities over explicit messaging on DeviceNet.

Message lengths and slave device types impact transaction message completion times. If the processor has queued multiple Explicit Message Transactions to the scanner module for multiple slave devices, the transactions with the slaves may not complete in the order in which the requests were received. The slave responses are queued to the 64 word Block Transfer Read in the order in which they are received. As response transaction blocks are uploaded, the processor's program matches the responses to the requests using the TXID field.

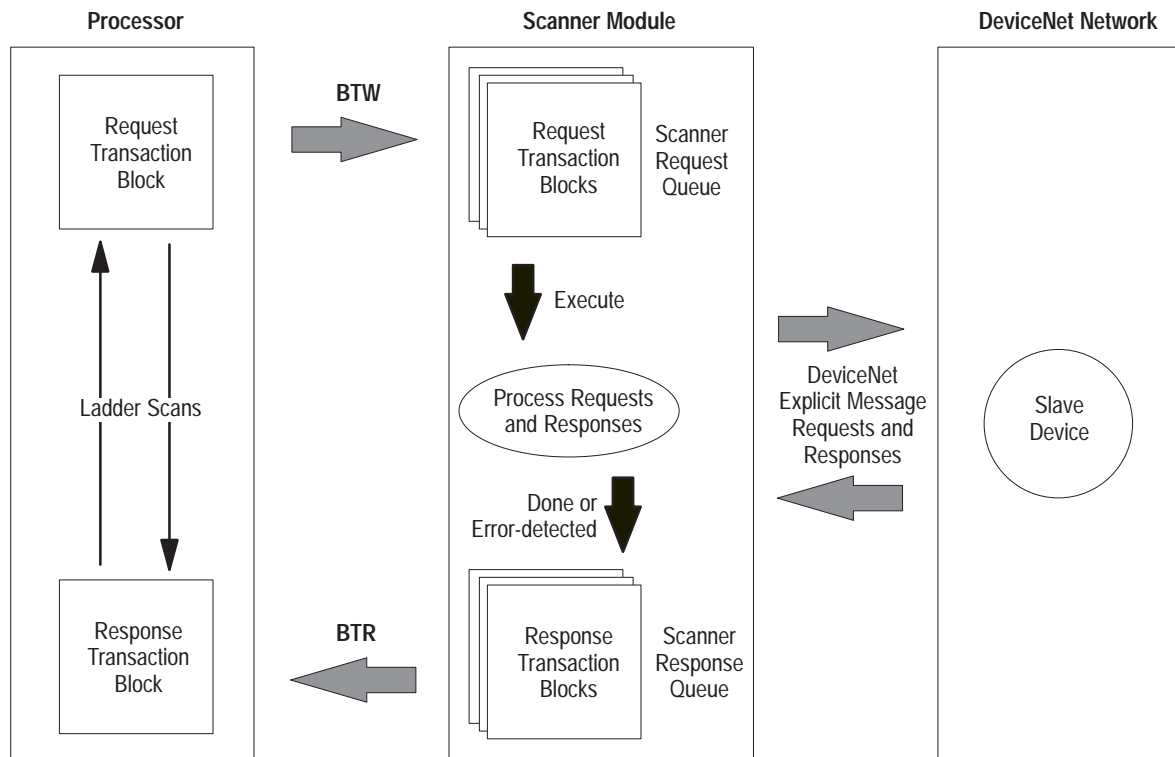

Explicit Message Program Control Limitations

- The processor is always the DeviceNet client and the slave is always the DeviceNet server.
- A maximum of 10 Explicit Message Request Transaction Blocks with the execute command can be queued to the scanner module at any time. For example, 5 Block Transfer Write files containing two transactions each, can be performed at any time. The scanner module receives and deletes any additional client/server requests with the execute command over the maximum of 10.

As transactions are removed from the queue and response transaction blocks are returned to the processor, additional transaction blocks can be issued in their place, as long as the total does not exceed ten.

- The scanner module supports two transaction blocks per upload and download.
- Request Transaction Blocks can only be queued for slave devices of the scanner module and must appear in the scanner module's scan list.
- If a slave device is not communicating at the time the scanner module processes its Request Transaction Block, the scanner module will return an error status for that transaction.
- At a minimum, the scanner module supports the following DeviceNet services in Request Transaction Blocks.

Service Name	Service Code	Example
Get_Attribute_Single	0E _{hex}	Upload a single parameter value from a device
Set_Attribute_Single	10 _{hex}	Download a single parameter value to a device
Get_Attribute_All	01 _{hex}	Upload all parameter values from a device
Set_Attribute_All	02 _{hex}	Download all parameter values to a device

- Continuous Block Transfers of 64 words are not supported.
- All transaction blocks are processed, therefore, any unused transaction blocks must be left blank.
- Client/Server commands and requests with transaction IDs that are in use are deleted by the scanner module.
- If a slave device returns a DeviceNet error in response to the request downloaded from the processor, the scanner recognizes the error as a successful transaction (status code =1).

A failure to respond to the request within the number of retries or timeout period specified for the Explicit Message Connection is recognized by the scanner module as an error. The error code is returned in the status attribute of the transaction header.

Explicit Messaging Ladder Logic Program

This section provides the explicit message ladder logic program and data monitor results.

Enable Rung B3:0 to initiate the download process to the AdaptaScan. File N20:0 contains the APM command. The DeviceNet address being written to, in this example, is 10 or 0AH. The N7 inputs are needed if the code from page 12-5 is used.

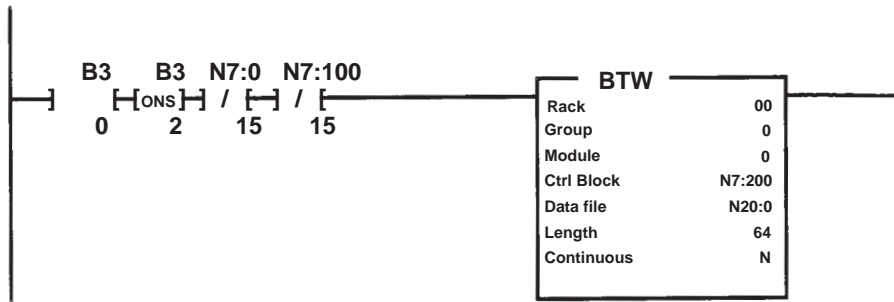

After BTW is complete, initiate the the BTR statement to retrieve the response code. The N7 inputs are needed if the code from page 12-5 is used.

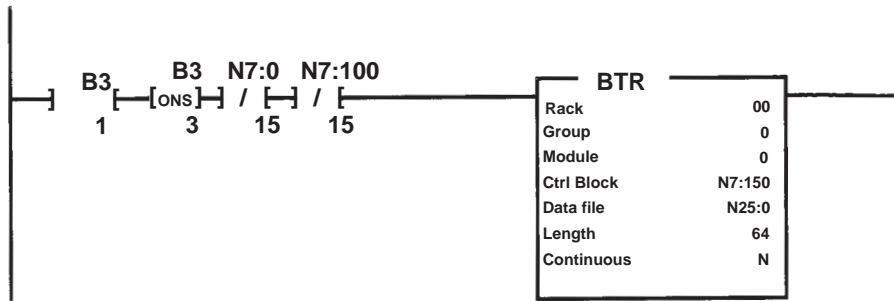

Note: You can write code to continuously change the TXID for the next transaction. Refer to page 12-21 for information regarding formatting the explicit message transaction block

Example Data Tables

Address	Data = Hex Code (matchcode download of 0300 data)								
N20:0	0101	000C	1003	00CE	0001	0003	0004	3330	3030

Address	Response File (good response)	
N25:0	0101	900C

Address	Data = Hex Code (Turn on LED 1)							
N20:0	0101	0008	1003	00C9	0002	0003	0001	

Notes on using Explicit Messaging

- You can send messages sequentially from the PLC-5 to different bar code readers, but the response will not update properly (when the response is read in N25:0).
- The TXID byte does not need to be incremented, although you may not know where the response came from.
- To receive the correct response from the command sent from the PLC-5 you must:
 1. Send command down, matchcode download (TXID=11).
 2. Send a 03 in the status command. Refer to page 12-21 for more information.
 3. Increment TXID to 12.
 4. Send command down, turn on LED 1 (TXID=12).
 5. View N25:0 for response to step 4.
 6. Confirm that TXID=12. If your response is 90, the command was sent correctly. If you receive a 94, the command was not sent correctly.
- If an incorrectly formatted command is sent from the PLC-5, you must send a 03 in the status command byte in order for the system to operate properly.

Troubleshooting Your Module

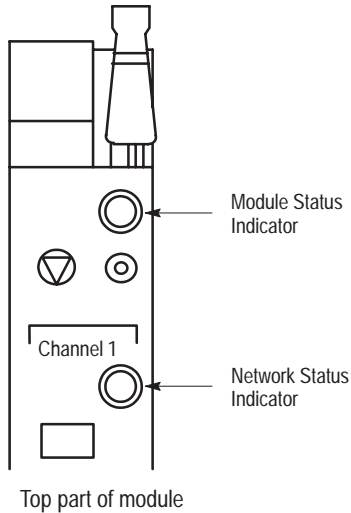

The bicolor (green/red) module status indicator displays device status. The LED indicates whether the device has power and is functioning properly.

If the Module LED is	this indicates	Take this action
Off	there is no power applied to the module.	Apply power.
Solid green	the module is operating in normal condition.	None
Flashing green	the module is not configured.	Configure the module.
Flashing red	there is invalid configuration.	Check configuration setup and verify dip switch settings.
Solid red	the module has an unrecoverable fault.	Replace the module.

Channels 1 and 2 each have a bicolor (green/red) network status indicator. The following table provides troubleshooting information about the Channel 1 and 2 communication links.

If the NET indicator is	this indicates	Take this action
Off	the channel is disabled for DeviceNet communication.	Power-up the module, provide network power to channel, and be sure channel is enabled in both the module configuration table and module command word.
Flashing green	the channel is enabled but no communication is occurring.	Configure scan list table for channel to add devices.
Solid green	all slave devices in the scan list table are communicating normally with the module.	None.
Solid red	the module may be defective.	Reset module. If failures continue, replace module.
Flashing red	at least one of the slave devices in the module's scan list table has failed to communicate with the module. The network has faulted.	Examine the failed device and the scan list table for accuracy.

Top part of module

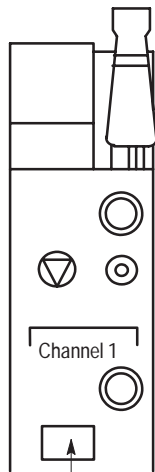
Node Address /
Status Indicator

Your 1771-SDN Scanner Module has a node address/status indicator that uses numeric displays to indicate diagnostic information about your module. The display flashes at approximately 1 second intervals, depending on network traffic. The following table summarizes the meanings of the numeric codes.

Numeric Code	Indicates	Take this action
Network Address Displays 0 - 63	normal operation. The numeric display matches the scanner's node address on the DeviceNet network.	None.
70	module failed Duplicate Node Address check.	Change the module channel address to another available one. The node address you selected is already in use on that channel.
71	illegal data in scan list table (node number alternately flashes).	Reconfigure the scan list table and remove any illegal data.
72	slave device stopped communicating (node number alternately flashes).	Inspect the field devices and verify connections.
73	device key parameters do not match scan list table entry (node number alternately flashes).	Enter a matching scan list device ID.
74	data overrun on port detected.	Modify your configuration and check for invalid data. Check network communication traffic.
75	no network traffic has been detected.	Verify connections.
76	no direct network traffic for module detected.	None. The module hears other network communication.
77	data size expected does not match scan lists entry (node number alternately flashes).	Reconfigure your module for the correct transmit and receive data sizes
78	slave device in scan list table does not exist (node number alternately flashes).	Add the device to the network, or delete the scan list entry for that device.
79	module has failed to transmit a message.	Make sure that your module is connected to a valid network. Check for disconnected cables.
80	module is in IDLE mode.	Place PLC-5 in Run mode.
81	module is in FAULT mode.	Check ladder program for cause of fault bits.
82	error detected in sequence of fragmented I/O messages from device (node number alternately flashes).	Check scan list table entry for slave device to make sure that input and output data lengths are correct. Check slave device configuration.
83	slave device is returning error responses when module attempts to communicate with it (node number alternately flashes).	Check accuracy of scan list table entry. Check slave device configuration. Slave device may be in another master's scan list. Reboot slave device.
84	module is initializing the DeviceNet channel.	None. This code clears itself once module attempts to initialize all slave devices on the channel.
85	data size returned is bigger than 255 bytes (node number alternately flashes).	Configure device for smaller data size.
86	device is producing idle state data while the scanner is in Run Mode.	Check device configuration/slave node status.
88	this is not an error. At power-up and reset, the module displays all 14 segments of the node address and status display LEDs.	None.

Table continued on the next page.

Numeric Code	Indicates	Take this action
90	user has disabled communication port	reconfigure your module. Check the disable bit in the Module Command Register.
91	bus-off condition detected on comm port. module is detecting communication errors.	Check DeviceNet connections and physical media integrity. Check system for failed slave devices or other possible sources of network interference.
92	no network power detected on comm port.	Provide network power. Make sure that module drop cable is providing network power to module comm port.
95	application FLASH update in progress.	None. Do not disconnect the module while application FLASH is in progress. You will lose any existing data in the module's memory.
97	module halted by user command.	Check ladder program for cause of fault bits.
98	Unrecoverable firmware failure.	Service or replace your module.
99	Unrecoverable hardware failure.	Service or replace your module.

Downloading Other Host Commands

You can download other host commands using the same procedures described in the match code example. The following tables provide the commands and responses for the other host commands (all values are hexadecimal).

Read Performance Indicator Command

Packet Contents	Data Sent
DeviceNet Address	3F*
Get Performance Request	4C
Class	C8
Instance Number (LSB)	01
Instance Number (MSB)	00

*3F = Address 63, modify as required

Read Performance Indicator Response

Packet Contents	Response
DeviceNet Address	3F
Get Performance Response	CC
Data (LSB)	01
Data (MSB)	00

Reset Package Counter Command

Packet Contents	Data Sent
DeviceNet Address	3F*
Set Attribute Request	10
Class	D2
Instance Number (LSB)	00
Instance Number (MSB)	00
Attribute Number- Reset Counters	09
Data	01

*3F = Address 63, modify as required

Reset Package Counter Response

Packet Contents	Response
DeviceNet Address	3F
Set Attribute Response	90

Read Match Counters Command

Packet Contents	Data Sent
DeviceNet Address	3F*
Get Attribute Request	0E
Class	CE
Instance Number (LSB)	01
Instance Number (MSB)	00
Attribute Number	08

*3F = Address 63, modify as required

Read Match Counters Response

Packet Contents	Response
DeviceNet Address	3F
Get Attribute Response	8E
Data	6C, 08, 00, 00

Read Package Counters Command

Packet Contents	Data Sent
DeviceNet Address	3F*
Get Attribute Request	0E
Class	D2
Instance Number (LSB)	01
Instance Number (MSB)	00
Attribute Number- Match Count	08

*3F = Address 63, modify as required

Read Package Counters Response

Packet Contents	Response
DeviceNet Address	3F
Get Attribute Response	8E
Data	6C, 08, 00, 00

Reset Match Counters Command

Packet Contents	Data Sent
Response Codes	3F*
Set Attribute Request	10
Class	CE
Instance Number (LSB)	00
Instance Number (MSB)	00
Attribute Number- Reset Counters	0B
Data	01

*3F = Address 63, modify as required

Read Message Command

Packet Contents	Data Sent
DeviceNet Address	3F*
Get Attribute Request	0E
Class	CC
Instance Number (LSB)	00
Instance Number (MSB)	00
Attribute Number - Message	14

*3F = Address 63, modify as required

Read LED Status Command

Packet Contents	Data Sent
DeviceNet Address	3F*
Read LEDS Request	43
Class	CB
Instance Number (LSB)	01
Instance Number (MSB)	00

*3F = Address 63, modify as required

Reset Match Counters Response

Packet Contents	Response
DeviceNet Address	3F
Set Attribute Response	90

Read Message Response

Packet Contents	Response
DeviceNet Address	3F
Get Attribute Response	8E
Data (LSB)	04
Data (MSB)	00
ASCII Message Data	30*
ASCII Message Data	32
ASCII Message Data	30
ASCII Message Data	30

* Example data = 0200

Read LED Status Response

Packet Contents	Response
3F	3F
Read LEDS Response	C3
I/O 1	See Table Next Page
I/O 2	See Table Next Page
Trigger / Read	See Table Next Page
On Symbol	See Table Next Page
Laser On	See Table Next Page
Module	See Table Next Page
Network	See Table Next Page

Set Output Timer Command

Packet Contents	Data Sent
DeviceNet Address	3F*
Set Attribute Request	10
Class	D0
Instance Number (LSB)	02
Instance Number (MSB)	00
Attribute Number - Max Time	09
Data (LSB)	FA
Data (MSB)	00

*3F = Address 63, modify as required

** Time in milliseconds

Set Output Timer Response

Packet Contents	Response
DeviceNet Address	3F
Set Attribute Response	90

LED Status Response

Byte	Bits	LED Indicator	Data at Indicated Bit Address = LED State							
			0 = Off	1 = Yellow	2 = Green	3 = Red	4 = Not Used	5 = Flash Yellow	6 = Flash Green	7 = Flash Red
0	0-2	I/O 1	OFF	ON						
	3-5	I/O 2	OFF	ON						
1	0-2	TRIGGER / READ	No Trigger	Triggered	Valid Read					
	3-5	ON SYMBOL	Not Reading	Reading				Read <100%		
2	0-2	LASER ON	OFF	ON						
	3-5	MODULE	No Power		Device OK	Hardware Fault			Power Up	Minor Fault
3	0-2	NETWORK			DeviceNet OK	DeviceNet Fault			Established	No Response
	3-5									

Communicating with a 2760-RB Module over an RS-232 Link

Overview

This application describes how to connect and configure an AdaptaScan Bar Code Reader to the 2760-RB interface module via “dumb terminal protocol” RS-232, using the 2760-SFC1 or -SFC2 protocol cartridge.

The application includes cable diagrams and configuration information for the AdaptaScan readers. It also includes a sample PLC-5 program which is needed to establish communication from the PLC-5 processor to the 2760-RB module.

Hardware Requirements

The hardware items required for this application are:

- 2755-SN3, -SN5 or -SN8 AdaptaScan Bar Code Reader
- 2755-NB40 or -NB41 Wiring Base
- 2755-PW46 or -PW47 Power Supply
- 2755-NC43 or -NC48 Configuration Cable
- 2760-RB Interface Module
- 1771 chassis
- PLC-5 processor
- 2760-SFC1 or -SFC2 protocol cartridge
- appropriate cables to program the PLC-5 and to configure the 2760-RB module and bar code reader.
- Computer running Windows 3.1 (or later) or Windows 95
- 9-to-25 Pin Adapter (for computer with a 25-pin COM port)

Software Requirements

The software requirements for this application are:

- 2755-ASN AdaptaScan Offline Programming Software
- terminal emulation software to program the 2760-RB module
- PLC-5 Programming Software

Related Publications

Publications you might want to refer to include:

Publication	Description
2755-837	AdaptaScan Bar Code Readers User Manual
2755-838	AdaptaScan Software User Manual
2760-ND001	2760-RB Interface Module User Manual
2760-ND003	2760-SFC1 Protocol Cartridge User Manual
2760-822	2760-SFC2 Protocol Cartridge User Manual

In addition, you may want to refer to the PLC-5 Hardware and Software User Manuals.

PLC-5 Compatibility

Refer to the following table for hardware compatibility in this application example.

Use the following 2760-RB Interface Module type	with the following PLC-5 type	
	PLC-5, -15, -25, etc.	New Generation PLC-5 (Series A, Rev. C or above)
Series A, Rev. G or below	Refer to the sample PLC-5 program on page 13-6.	Refer to the sample PLC-5 program on page 13-6. (Set BT compatibility bit S26/4 while in program mode.)
Series A, Rev. H or above		Refer to the sample PLC-5 program on page 13-7. (Add ladder logic using IIN update of RB. BTR must be before BTW.)

Connecting the RB Module to the Reader

The 2760-RB configuration example includes sample configuration screens and DIP switch settings needed to establish communication with the AdaptaScan Reader via RS-232.

Dip Switch Side View

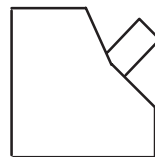

Switch pushed toward top (off position).

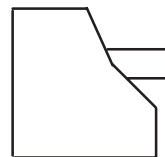

Switch pushed toward bottom (on position).

Classic PLC-5 Processor DIP Switches

Switch #	Switch Lever #							
	1	2	3	4	5	6	7	8
SW-1	on	on	on	on	on	on	on	off
SW-2	on	on	on	on	on	on	on	off
SW-3	on	on	off	off	Not Applicable			

Enhanced PLC-5 Processor DIP Switches

Switch #	Switch Lever #									
	1	2	3	4	5	6	7	8	9	10
SW-1	on	on	on	on	on	on	on	on	on	off
SW-2	on	on	on	off	off	on	on	off	on	off

I/O Chassis Backplane DIP Switches

Switch Lever #							
1	2	3	4	5	6	7	8
off	off	off	off	off	on	off	off

2760-RB Module DIP Switches

Switch #	Switch Lever #							
	1	2	3	4	5	6	7	8
SW-1	off	off	off	off	off	off	off	off
SW-2	off	off	off	off	off	off	off	off
SW-3	off	off	off	off	Not Applicable			
SW-4	off	off	on	off				

The 2760-RB module is placed in the 1771 chassis in slot 0 next to the PLC. For this application, the AdaptaScan Reader communicates through port 1 on the 2760-RB. A 1771-ASB module can also be used to communicate with the 2760-RB module over the chassis backplane to Remote I/O.

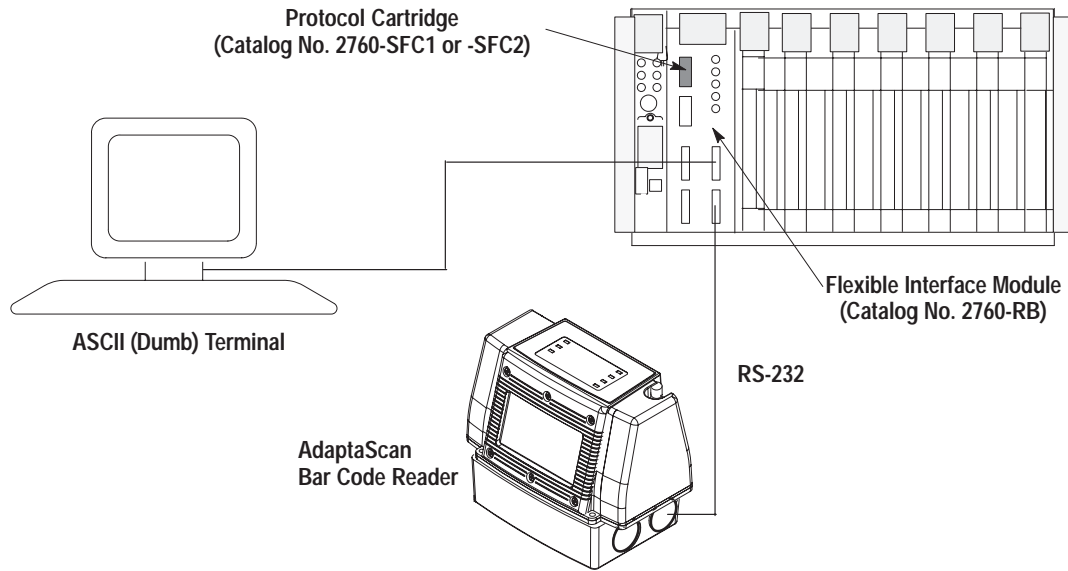

Cabling

Cable 1 must be constructed to connect a configuration terminal to the 2760-RB Module Configuration port.

Cable 2 must be constructed to connect the RS232/422 port of the bar code reader wiring base to Port 1 on the 2760-RB module. Refer to following cabling diagrams.

Cable 1

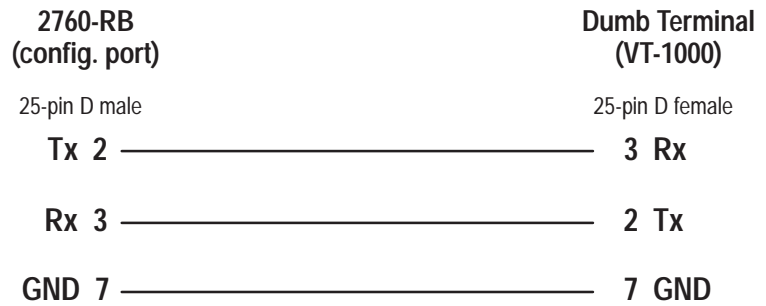

Cable 2

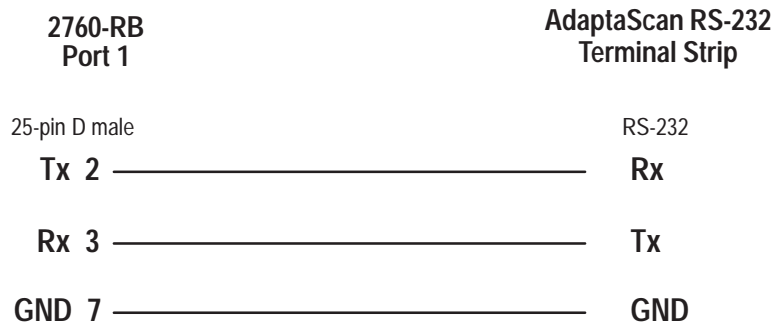

Configuring the PLC-5 Processor

A sample PLC program appropriate for using a PLC 5/15/25 with a 2760-RB module appears below.

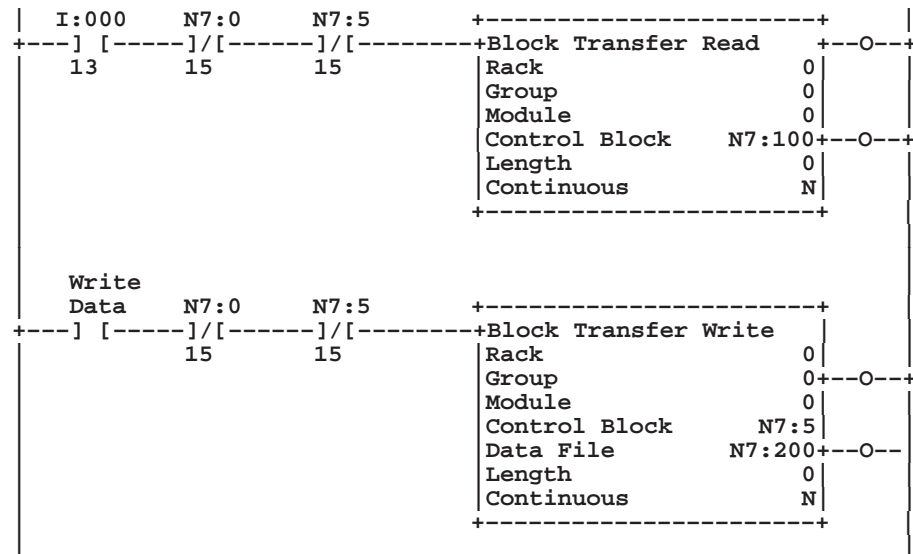

Refer to your PLC-5 Instruction Reference Manual for detailed information on using the PLC-5 programming software.

Using the 2760-RB Module, Revision H or Above, with the New Generation PLC-5 Processor

When the 2760-RB, revision H or above, is used with the new generation PLC-5 processors in a local chassis, there is a possibility that the PLC will not see the BRR bit from the 2760-RB. For the PLC-5 to see the BTR bit, an odd number of image scans must occur. To ensure that the BTR instruction sees the BRR bit (bit 13) you must place an Immediate Input Instruction addressed to the BRR bit in another rung just before the Block Transfer Read (BTR) rung. This ensures that the BRR bit is seen by the NP-5 processor.

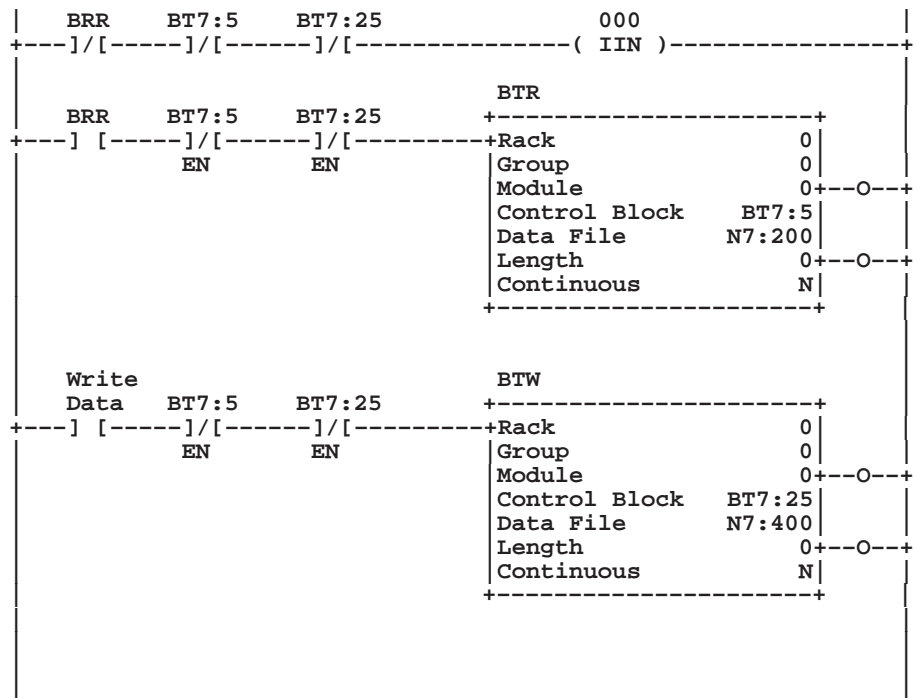

Note: BTR must come before BTW.

Refer to your PLC-5 user manual for detailed information on using the PLC-5 programming software.

Configuring the 2760-RB Interface Module

The configuration screens for the 2760-RB should be entered exactly as shown. These parameters then need to be saved.

Both the bar code reader and the 2760-RB module are configured to send and recognize the Carriage Return [cr], Line Feed [lf] characters to identify a message. When the 2760-RB senses information entering Port 1, it will look for the Cr, Lf. When it sees these trailers, it will Block transfer read (BTR) the preceding bar code data into the PLC program.

To configure the 2760-RB module:

1. Set all 2760-RB module DIP switches to Off.
2. Connect the smart cable to the Configuration port of the 2760-RB module and the serial port of the computer.
3. Send a “break sequence” to the 2760-RB module via the Terminal Emulator:
 - A. Set the baud rate to 9600, 8 data bits, 1 stop bit, no parity, no flow control, and either COM1 or COM2 depending on the smart cable connection.
 - B. Program a function key to send the “break sequence” by using the Ctrl-Shift-Break command. (This step is specifically for Windows 3.1 Terminal Emulation.)
 - C. Send the break sequence to call up the 2760-RB module configuration menu.
4. Select menu item 3: Device port protocol names. Set to:
PORT1=COPYRIGHT 1989 ALLEN-BRADLEY COMPANY INC.
2760-SFC2 DT SERIES A REVISION A (YES/NO)=YES
5. Select menu item 21: Identification numbers. Select:
DUMB TERM. UNSPECIFIED PROTOCOL, 13FH (YES/NO)=YES

6. Select option 11: Configuration parameters. Set to:

```
MODEM CONTROL (ENABLE/DISABLE)=DISABLE
9600 BITS PER SECOND (YES/NO)=YES
8 BITS NO PARITY (YES/NO)=YES
XON/XOFF (ENABLE/DISABLE)=DISABLE
RS232 (YES/NO)=YES
RECEIVE MATRIXING (ENABLE/DISABLE)=ENABLE
BYTE SWAPPING (ENABLE/DISABLE)=DISABLE
BINARY DATA NO CONVERSIONS (YES/NO)=YES
HDR/TLR ON OUTPUT (ENABLE/DISABLE)=ENABLE
HEADER BYTE LENGTH (DEC 0...4)= 0
HEADER DATA[0](HEX 0...FF)=0
HEADER DATA[1](HEX 0...FF)=0
HEADER DATA[2](HEX 0...FF)=0
HEADER DATA[3](HEX 0...FF)=0
TRAILER BYTE LENGTH (DEC 0...4)=2
TRAILER DATA[0](HEX 0...FF)=0d
TRAILER DATA[1](HEX 0...FF)=0a
TRAILER DATA[2](HEX 0...FF)=0
TRAILER DATA[3](HEX 0...FF)=0
```

Type save or quit to exit out of the editor.

7. Verify that the 2760-RB is in chassis 0, group 0 module 0.
8. Save the above configuration.

Configuring the Reader

This section shows how to configure the AdaptaScan Bar Code Reader using the AdaptaScan Software (Catalog No. 2755-ASN).

The procedures in this section show how to:

- configure a DeviceNet address
- configure a bar code label and symbol
- configure the scanner
- configure the decoder trigger
- configure the serial port
- configure the content and format of messages

These procedures provide general guidelines for setting up an application. You may need to modify the configuration for your application needs.

Create a New Project

Create a new project named RB_RS232 for one AdaptaScan Bar Code Reader (Bar Code Reader 1).

1. Choose New from the Project menu to create a new project.
2. Click the New button to add a bar code reader (Bar Code Reader 1) to the project.

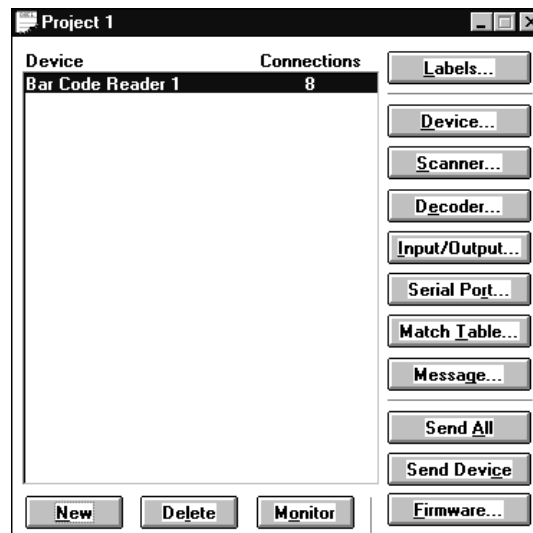

3. Choose Edit from the Project menu to rename the project **RB_RS232**.

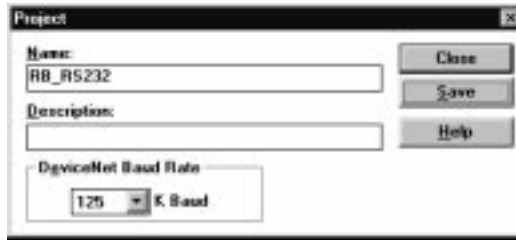

4. Click Save to save the project under the new name and then Close to return to the Project dialog.

Define the Bar Code Label

1. Click the Labels button to open the Bar Code Labels dialog.
2. Click the New button to define a label.

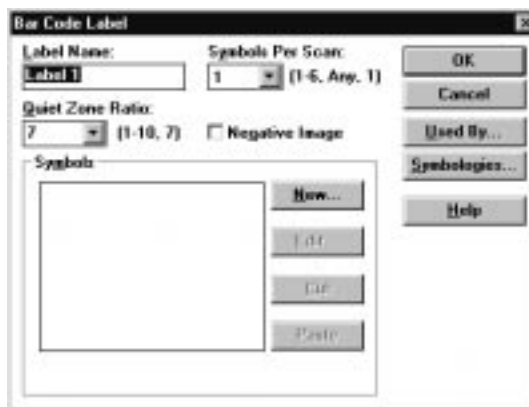

3. Click the New button to define a symbol for the label.

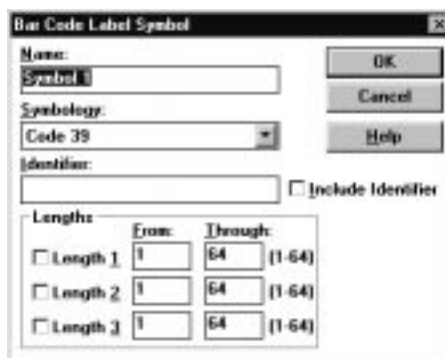

4. Select a symbology and any other parameters (Identifier, Lengths) required by your application.
5. Click OK until you return to the Bar Code Labels dialog.
6. Click Save and then Close to return to the main Project dialog.

Define the DeviceNet Address

1. Click the Device button on the Project dialog.

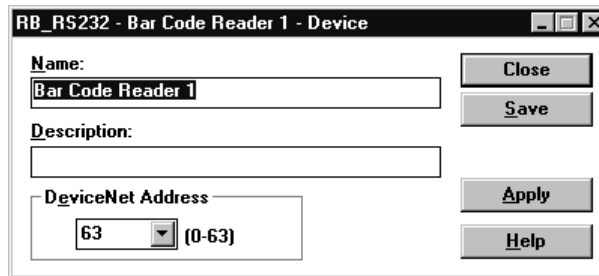

The screenshot shows a dialog box titled "RB_RS232 - Bar Code Reader 1 - Device". It contains the following fields and controls:

- Name:** A text box containing "Bar Code Reader 1".
- Description:** An empty text box.
- DeviceNet Address:** A dropdown menu showing "63" and a range "(0-63)".
- Buttons:** "Close", "Save", "Apply", and "Help" are located on the right side of the dialog.

2. Set the DeviceNet address.
3. Connect the 2755-NC43 or -NC48 Configuration Cable to the reader.
4. Click the Apply button.
5. Click Save and Close to return to the Project dialog.

Configure the Scanner

1. Click the Scanner button on the Project dialog to open the Scanner dialog.

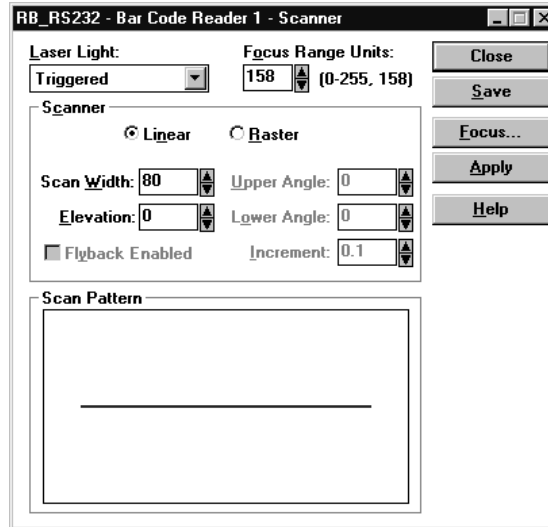

2. Configure the scan pattern and use the Focus procedure for optimum scanner focus.
3. Click the Close button and return to the Project dialog.

Configure the Decoder Trigger

This application uses a Timer to trigger the reader's decoder. The Timer is typically used during application setup. Refer to Publication No. 2755-837 for other input sources that trigger the decoder.

1. Click the Decoder button from the main Project dialog.
2. Under Triggered By, select **Timer** from the Input list.



3. Click the Save button.

Configure the Serial Port

1. Click the Serial Port button on the main Project dialog.

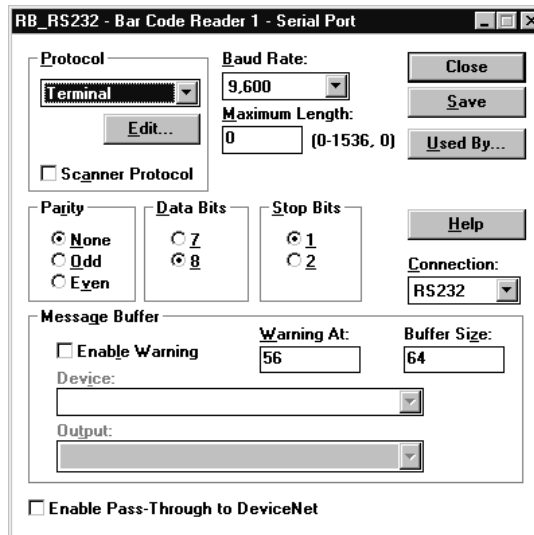

2. Verify that **Terminal** is selected in the Protocol list box. Also verify that the settings match the Channel 0 User settings.
3. Click the Edit button to open Terminal dialog.
4. Type `\r\n` in the trailer field.

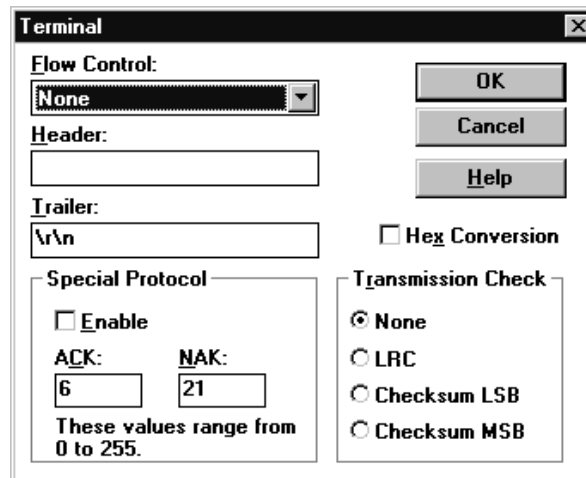

5. Click OK to exit the dialog.
6. Click the Save and then the Close button on the Serial Port dialog to return to the main Project dialog.

Create a Message

The Message dialogs define the format and content of message data sent to the RB module by the reader when bar codes are decoded.

1. Click the Message button from the main Project dialog.
2. Under Triggered By, check the Enable check box.



3. Under Device, select **Bar Code Reader 1**.
4. Under Input, select **[Decoder]**.
5. Click the New button to define a message field.

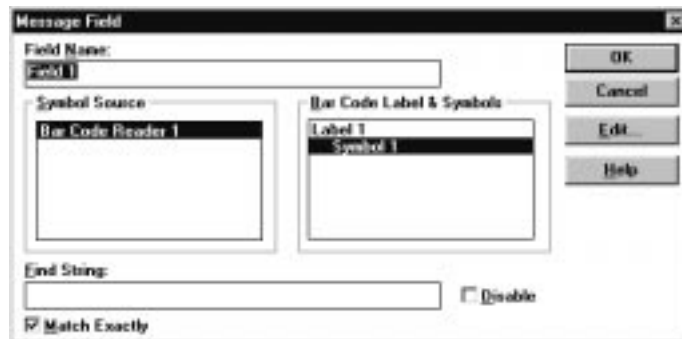

6. Under Symbol Source, select **Bar Code Reader 1**.
7. Under Bar Code Labels & Symbols, select **Symbol 1**.
8. Check (enable) the Match Exactly check box.
9. Click the Edit button to open the Message Field Edit dialog.

- Under Replacement Strings, type **no read** in the Fail: field.

Bar code data is sent to the controller on a valid read. The Fail string sends the characters “no read” when a no read occurs.

Message Field Edit

Include in Field

Source

Symbology

Data Format

Type: Text

Alignment: Left

Length: 14 (1-64, 14)

Fill Character: 32 (0-255)

Replacement Strings

Pass:

Fail: no read

OK

Cancel

Help

- Click OK to return to the Message Field dialog.
- Click OK to return to the Message dialog.
- Click Save and then Close to return to the main Project dialog.

Sending the Configuration to the Reader

From the main Project dialog, click the Send Device button to download the configuration to the bar code reader.

Use the Monitor dialog to verify the decoding of bar code labels.

Communicating with a 2760-RB Module on a DH-485 Network

Overview

This application describes how to connect and configure an AdaptaScan Bar Code Reader to the 2760-RB interface module via DH485, using the 2760-SFC2 protocol cartridge.

The application includes cable diagrams and configuration information for the AdaptaScan readers. It also includes a sample PLC-5 program which is needed to establish communication from the PLC-5 processor to the 2760-RB module.

Hardware Requirements

The hardware items required for this application are:

- 2755-SN3, -SN5 or -SN8 AdaptaScan Bar Code Reader (v7.1 firmware or later)
- 2755-NB40 or -NB41 Wiring Base
- 2755-PW46 or -PW47 Power Supply
- 2755-NC43 or -NC48 Configuration Cable
- 2760-RB Interface Module
- 1771 chassis
- PLC-5 processor
- 2760-SFC2 protocol cartridge
- appropriate cables to program the PLC-5 and to configure the 2760-RB module and bar code reader.
- Computer running Windows 3.1 (or later) or Windows 95
- 9-to-25 Pin Adapter (for computer with a 25-pin COM port)

Software Requirements

The software requirements for this application are:

- 2755-ASN AdaptaScan Offline Programming Software
- terminal emulation software to program the 2760-RB module
- PLC-5 Programming Software

Related Publications

Publications you might want to refer to include:

Publication	Description
2755-837	AdaptaScan Bar Code Readers User Manual
2755-838	AdaptaScan Software User Manual
2760-ND001	2760-RB Interface Module User Manual
2760-822	2760-SFC2 Protocol Cartridge User Manual

In addition, you may want to refer to the PLC-5 Hardware and Software User Manuals.

PLC-5 Compatibility

Refer to the following table for hardware compatibility in this application example.

Use the following 2760-RB Interface Module type	with the following PLC-5 type	
	PLC-5, -15, -25, etc.	New Generation PLC-5 (Series A, Rev. C or above)
Series A, Rev. G or below	Refer to the sample PLC-5 program on page 14-5.	Refer to the sample PLC-5 program on page 14-5. (Set BT compatibility bit S26/4 while in program mode.)
Series A, Rev. H or above		Refer to the sample PLC-5 program on page 14-6. (Add ladder logic using IIN update of RB. BTR must be before BTW.)

Connecting the RB Module to the Reader

The 2760-RB configuration example includes sample configuration screens and DIP switch settings needed to establish communication with the AdaptaScan Reader via DH-485.

Dip Switch Side View

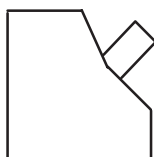

Switch pushed toward top (off position).

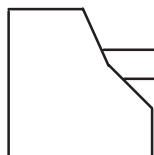

Switch pushed toward bottom (on position).

Classic PLC-5 Processor DIP Switches

Switch #	Switch Lever #							
	1	2	3	4	5	6	7	8
SW-1	on	on	on	on	on	on	on	off
SW-2	on	on	on	on	on	on	on	off
SW-3	on	on	off	off	Not Applicable			

Enhanced PLC-5 Processor DIP Switches

Switch #	Switch Level #									
	1	2	3	4	5	6	7	8	9	10
SW-1	on	on	on	on	on	on	on	on	on	off
SW-2	on	on	on	off	off	on	on	off	on	off

I/O Chassis Backplane DIP Switches

Switch Level #							
1	2	3	4	5	6	7	8
off	off	off	off	off	on	off	off

2760-RB Module DIP Switches

Switch #	Switch Level #							
	1	2	3	4	5	6	7	8
SW-1	off	off	off	off	off	off	off	off
SW-2	off	off	off	off	off	off	off	off
SW-3	off	off	off	off	Not Applicable			
SW-4	off	off	on	off				

The 2760-RB module is placed in the 1771 chassis in slot 0 next to the PLC. For this application, the AdaptaScan Reader communicates through port 1 on the 2760-RB. A 1771-ASB module can also be used to communicate with the 2760-RB module over the chassis backplane to Remote I/O.

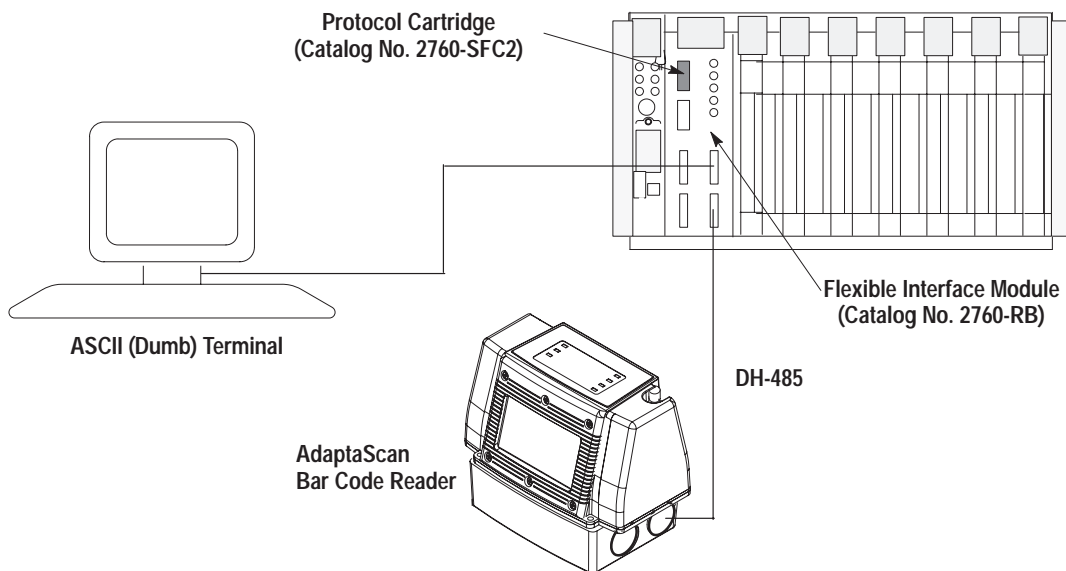

Cabling

Cable 1 must be constructed to connect a configuration terminal to the 2760-RB Module Configuration port.

Cable 2 must be constructed to connect the RS485 port of the bar code reader wiring base to Port 1 on the 2760-RB module. Refer to following cabling diagrams.

Cable 1

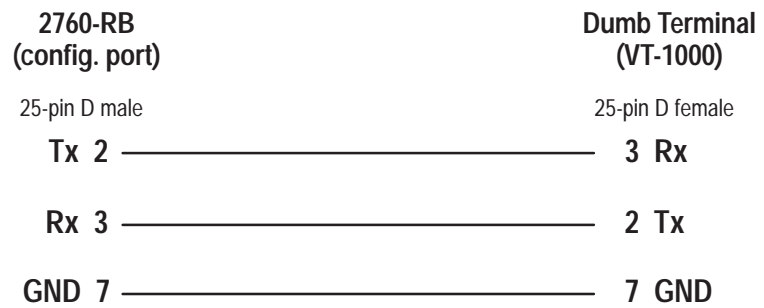

Cable 2

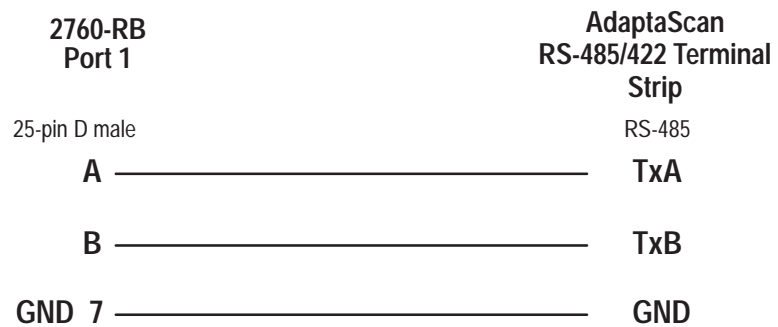

Configuring the PLC-5 Processor

A sample PLC program appropriate for using a PLC 5/15/25 with a 2760-RB module appears below.

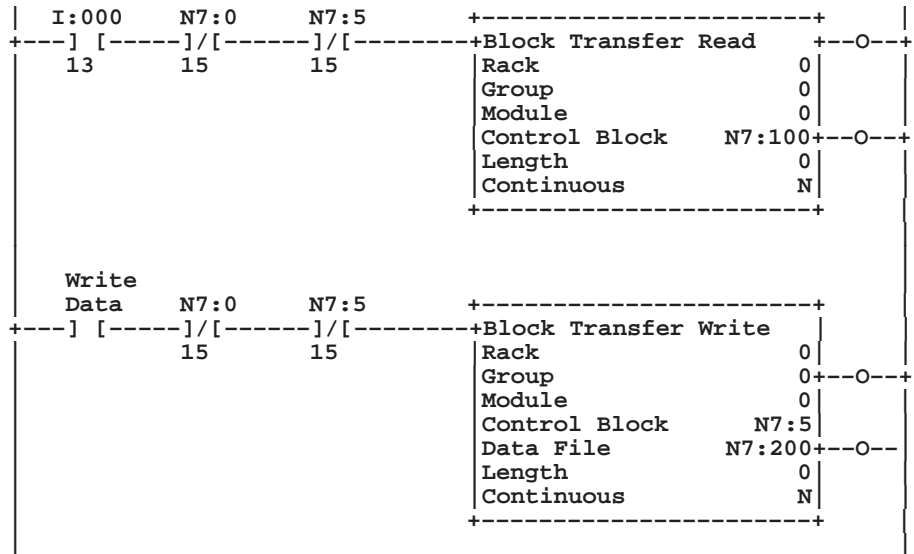

Refer to your PLC-5 Instruction Reference Manual for detailed information on using the PLC-5 programming software.

Using the 2760-RB Module, Revision H or Above, with the New Generation PLC-5 Processor

When the 2760-RB, revision H or above, is used with the new generation PLC-5 processors in a local chassis, there is a possibility that the PLC will not see the BRR bit from the 2760-RB. For the PLC-5 to see the BTR bit, an odd number of image scans must occur. To ensure that the BTR instruction sees the BRR bit (bit 13) you must place an Immediate Input Instruction addressed to the BRR bit in another rung just before the Block Transfer Read (BTR) rung. This ensures that the BRR bit is seen by the NP-5 processor.

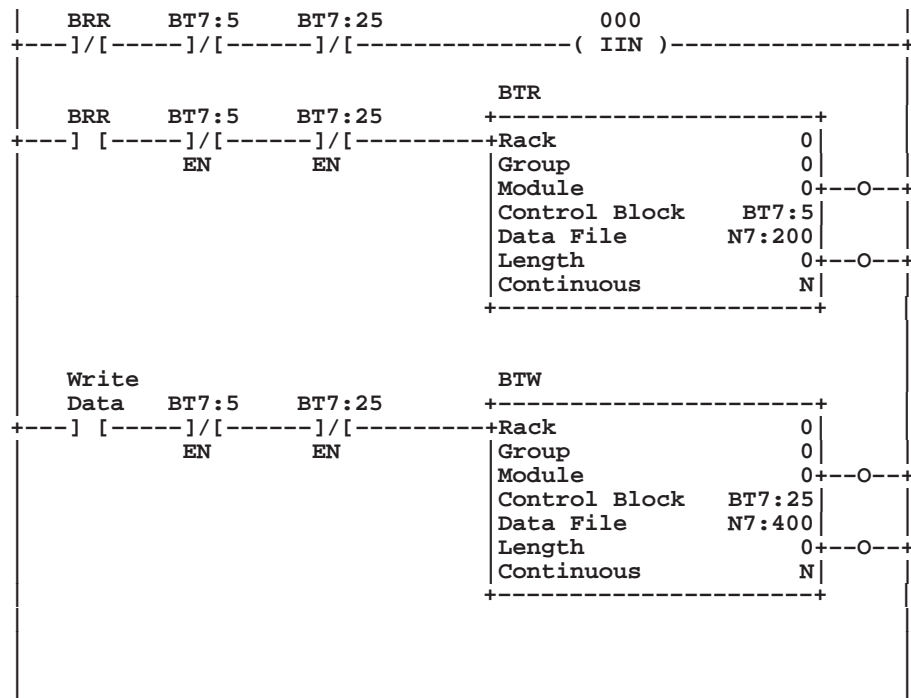

Note: BTR must come before BTW.

These parameters then need to be saved. Refer to your PLC-5 user manual for detailed information on using the PLC-5 programming software.

Configuring the 2760-RB Interface Module

The configuration screens for the 2760-RB should be entered exactly as shown.

Both the bar code reader and the 2760-RB module are configured to send and recognize the Carriage Return [cr], Line Feed [LF] characters to identify a message. When the 2760-RB senses information entering Port 1, it will look for the Cr, Lf. When it sees these trailers, it will Block transfer read (BTR) the preceding bar code data into the PLC program.

To configure the 2760-RB module:

1. Set all 2760-RB module DIP switches to Off.
2. Connect the smart cable to the Configuration port of the 2760-RB module and the serial port of the computer.
3. Send a “break sequence” to the 2760-RB module via the Terminal Emulator:
 - D. Set the baud rate to 9600, 8 data bits, 1 stop bit, no parity, no flow control, and either COM1 or COM2 depending on the smart cable connection.
 - E. Program a function key to send the “break sequence” by using the Ctrl-Shift-Break command. (This step is specifically for Windows 3.1 Terminal Emulation.)
 - F. Send the break sequence to call up the 2760-RB module configuration menu.
4. Select menu item 3: Device port protocol names. Set to:
PORT1=COPYRIGHT 1989 ALLEN-BRADLEY COMPANY INC.
2760-SFC2 LAN SERIES A REVISION B (YES/NO)=YES
5. Select menu item 21: Identification numbers. Select:
RS485 LAN 2755-DM6 ASCII MODE 0H (YES/NO)=YES
6. Select option 11: Configuration parameters. Set to:
SLOT TIME (NO. CHARS) (DEC 0 ... 255) = 15
INTER-CHAR TIME (NO. CHARS) (DEC 0 ... 255) = 7
IDLE TIME (NO. CHARS) (DEC 0 ... 255) = 3
RETRIES (DEC 0 ... 255) = 3
19,200 BITS PER SECOND (YES/NO)=YES
BCD NODE NUMBERS (ENABLE/DISABLE)= ENABLE
BYTE SWAPPING (ENABLE/DISABLE)=ENABLE
RECEIVE MATRIXING (ENABLE/DISABLE)=DISABLE
MATRIX ADDRESS (HEX 0 ... FFFF) = 0
RE-ESTABLISH FREQUENCY (DEC 0 ... 255)=5
POLL FREQUENCY/DESTINATION [0] (HEX 0 ... FFFF)=5
POLL FREQUENCY/DESTINATION [1] (HEX 0 ... FFFF)=105
POLL FREQUENCY/DESTINATION [2] (HEX 0 ... FFFF)=5
POLL FREQUENCY/DESTINATION [3] (HEX 0 ... FFFF)=5

Type save or quit to exit out of the editor.

7. Verify that the 2760-RB is in chassis 0, group 0 module 0.
8. Save the above configuration.

Configuring the Bar Code Reader

This section shows how to configure the AdaptaScan Bar Code Reader (with v7.1 firmware or later) using the AdaptaScan Software (Catalog No. 2755-ASN).

The procedures in this section show how to:

- define the DeviceNet node address of the AdaptaScan Reader
- configure a bar code label and symbol
- configure the scanner
- configure the decoder trigger
- configure the serial port
- configure the format of messages and the message destination

The steps may vary for some procedures because of the different requirements of applications. For example, the bar code labels may vary from one application to the next.

Create a New Project

Create a new project named RB_DH485 for the AdaptaScan Bar Code Readers.

1. Choose New from the Project menu to create a new project.
2. Click the New button to add a bar code reader to the project.

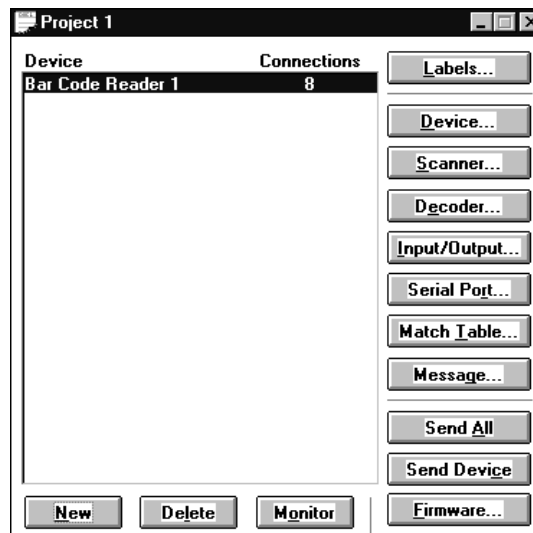

- Choose Edit from the Project menu to rename the project **RB_DH485**.

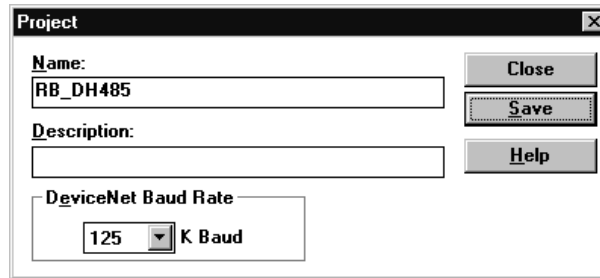

- Click Save to save the project under the new name and then Close to return to the Project dialog.

Define the Bar Code Label

- Click the Labels button to open the Bar Code Labels dialog.
- Click the New button to define a label.



- Click the New button to define a symbol for the label.

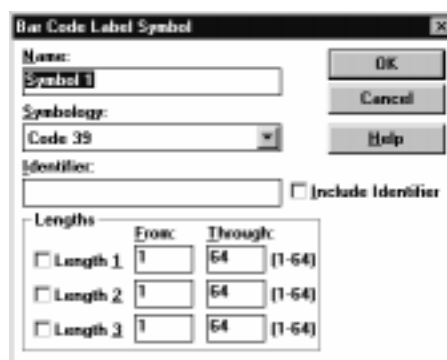

- Select a symbology and any other parameters (Identifier, Lengths) required by your application.
- Click OK until you return to the Bar Code Labels dialog.
- Click Save and then Close to return to the main Project dialog.

Define the DeviceNet Address

1. Click the Device button on the Project dialog.

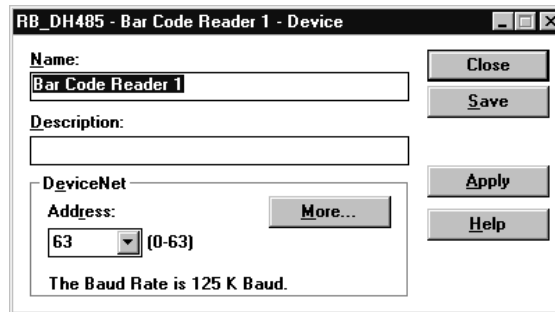

2. Set the DeviceNet address to 1.

Note: The DeviceNet address is not always the same as the DH-485 node address. A DH-485 node address is assigned later.

3. Connect the 2755-NC43 or -NC48 Configuration Cable to the reader.
4. Click the Apply button.
5. Click Save and Close to return to the Project dialog.

Configure the Scanner

1. Click the Scanner button on the Project dialog to open the Scanner dialog.

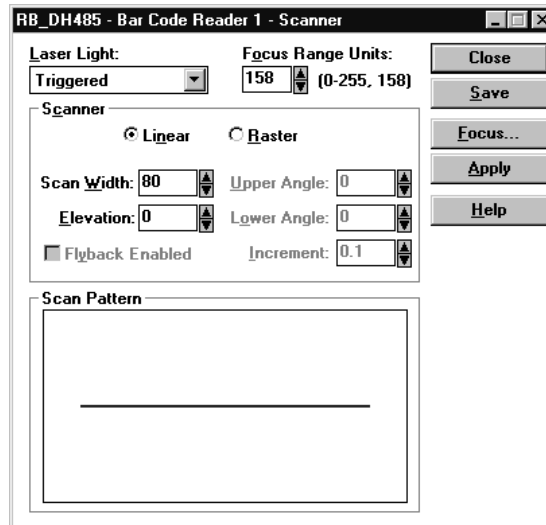

2. Configure the scan pattern and use the Focus procedure for optimum scanner focus.
3. Click the Close button and return to the Project dialog.

Configure the Decoder Trigger

This application uses a Timer to trigger the reader's decoder. The Timer is typically used during application setup. Refer to Publication No. 2755-837 for other input sources that trigger the decoder.

1. Click the Decoder button from the main Project dialog.
2. Under Triggered By, select **Timer** from the Input list.



3. Click the Save button.
4. Click the Close button and return to the main Project dialog.

Configure the Serial Port

1. Click the Serial Port button from the Project dialog.



2. Configure the serial port as follows:
 - From the Protocol list box, select **DH-485**
 - From the Baud Rate list box, select **19,200**
 - From the Connection list box, select **RS485**

The configuration must match the host configuration.

3. Click the Edit button under Protocol to edit the DH-485 parameters.

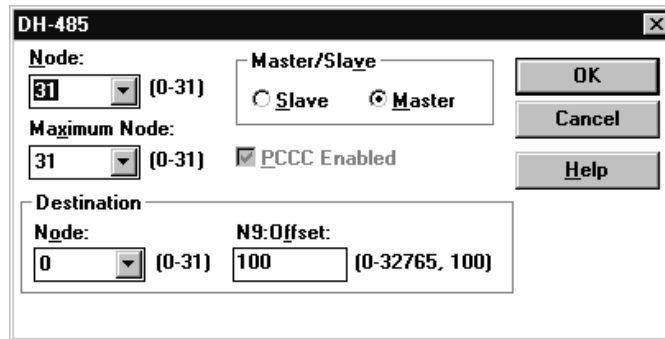

The screenshot shows a dialog box titled "DH-485" with a close button (X) in the top right corner. The dialog contains the following fields and controls:

- Node:** A dropdown menu showing "31" with "(0-31)" next to it.
- Maximum Node:** A dropdown menu showing "31" with "(0-31)" next to it.
- Master/Slave:** Two radio buttons, "Slave" (unselected) and "Master" (selected).
- PCCC Enabled:** A checked checkbox.
- Destination:** A section containing:
 - Node:** A dropdown menu showing "0" with "(0-31)" next to it.
 - N9:Offset:** A text input field showing "100" with "(0-32765, 100)" next to it.
- Buttons:** "OK", "Cancel", and "Help" buttons are located on the right side of the dialog.

Edit the parameters as follows:

- Select **Slave** under Master/Slave
 - From the Node list box, select **1**
This is the node address of the reader on the network.
4. Click OK to return to the Serial Port dialog.
 5. Click Save and then Close to return to the main Project dialog.

Create a Message

Data sent from the AdaptaScan Reader to the RB module uses messages.

1. Click the Message button from the main Project dialog.



2. Under Triggered By, check the Enable check box.
3. Under Device, select **Bar Code Reader 1**.
4. Under Input, select [**Decoder**].
5. Click the New button to create a message field.

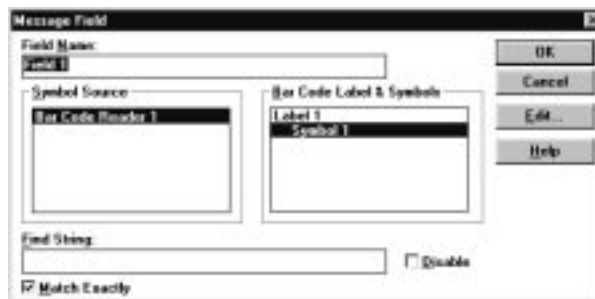

6. Under Symbol Source, select Bar Code Reader 1.
7. Under Bar Code Labels & Symbols, select **Symbol 1**.
8. Check (enable) the Match Exactly check box.

- Click the Edit button to open the Message Field Edit dialog.



- Under Replacement Strings, type **no read** in the Fail: box.

Bar code data is sent to the RB module on a valid read. The Fail string sends “no read” to the controller when a no read occurs on Bar Code Reader 1.

- Click OK to return to the Message Field dialog.
- Click OK again to return to the Message dialog.

Define the Message Format

- Click the Format button from the Message dialog.



- In the Trailer text box, type `\r\n` (for CR, LF).
- Under Message Destination, select **Serial Port**.
- Click OK to return to the Message dialog.
- Click Save and then Close to return to the Project dialog.

Sending the Configuration to the Reader

From the main Project dialog, click the Send Device button to download the configuration to the bar code reader.

Use the Monitor dialog to verify the decoding of bar code labels.

Downloading Match Codes via DH485 using a PLC-5 Processor and a 2760-RB Module

Overview

This application describes how to download match codes to the AdaptaScan Bar Code Reader from a PLC-5 processor via DH485 protocol, using the 2760-SFC2 protocol cartridge.

The application includes cable diagrams and configuration information for the AdaptaScan readers. It also includes a sample PLC-5 program which is needed to establish communication from the PLC-5 processor to the 2760-RB module.

Hardware Requirements

The hardware items required for this application are:

- 2755-SN3, -SN5 or -SN8 AdaptaScan Bar Code Reader (v7.1 firmware or later)
- 2755-NB40 or -NB41 Wiring Base
- 2755-PW46 or -PW47 Power Supply
- 2755-NC43 or -NC48 Configuration Cable
- 2760-RB Interface Module
- 1771 chassis
- PLC-5 processor
- 2760-SFC2 protocol cartridge
- appropriate cables to program the PLC-5 and to configure the 2760-RB module and bar code reader.
- Computer running Windows 3.1 (or later) or Windows 95
- 9-to-25 Pin Adapter (for computer with a 25-pin COM port)

Software Requirements

The software requirements for this application are:

- 2755-ASN AdaptaScan Offline Programming Software
- terminal emulation software to program the 2760-RB module
- PLC-5 Programming Software

Related Publications

Publications you might want to refer to include:

Publication	Description
2755-837	AdaptaScan Bar Code Readers User Manual
2755-838	AdaptaScan Software User Manual
2760-ND001	2760-RB Interface Module User Manual
2760-822	2760-SFC2 Protocol Cartridge User Manual

In addition, you may want to refer to the PLC-5 Hardware and Software User Manuals.

PLC-5 Compatibility

Refer to the following table for hardware compatibility in this application example.

Use the following 2760-RB Interface Module type	with the following PLC-5 type	
	PLC-5, -15, -25, etc.	New Generation PLC-5 (Series A, Rev. C or above)
Series A, Rev. G or below	Refer to the sample PLC-5 program on page 15-5.	Refer to the sample PLC-5 program on page 15-5. (Set BT compatibility bit S26/4 while in program mode.)
Series A, Rev. H or above		Refer to the sample PLC-5 program on page 15-6. (Add ladder logic using IIN update of RB. BTR must be before BTW.)

Connecting the RB Module to the Reader

The 2760-RB configuration example includes sample configuration screens and DIP switch settings needed to establish communication with the AdaptaScan Reader via DH-485.

Dip Switch Side View

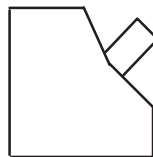

Switch pushed toward top (off position).

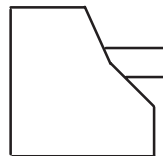

Switch pushed toward bottom (on position).

Classic PLC-5 Processor DIP Switches

Switch #	Switch Lever #							
	1	2	3	4	5	6	7	8
SW-1	on	on	on	on	on	on	on	off
SW-2	on	on	on	on	on	on	on	off
SW-3	on	on	off	off	Not Applicable			

Enhanced PLC-5 Processor DIP Switches

Switch #	Switch Level #									
	1	2	3	4	5	6	7	8	9	10
SW-1	on	on	on	on	on	on	on	on	on	off
SW-2	on	on	on	off	off	on	on	off	on	off

I/O Chassis Backplane DIP Switches

Switch Level #							
1	2	3	4	5	6	7	8
off	off	off	off	off	on	off	off

2760-RB Module DIP Switches

Switch #	Switch Level #							
	1	2	3	4	5	6	7	8
SW-1	off	off	off	off	off	off	off	off
SW-2	off	off	off	off	off	off	off	off
SW-3	off	off	off	off	Not Applicable			
SW-4	off	off	on	off				

The 2760-RB module is placed in the 1771 chassis in slot 0 next to the PLC. For this application, the AdaptaScan Reader communicates through port 1 on the 2760-RB. A 1771-ASB module can also be used to communicate with the 2760-RB module over the chassis backplane to Remote I/O.

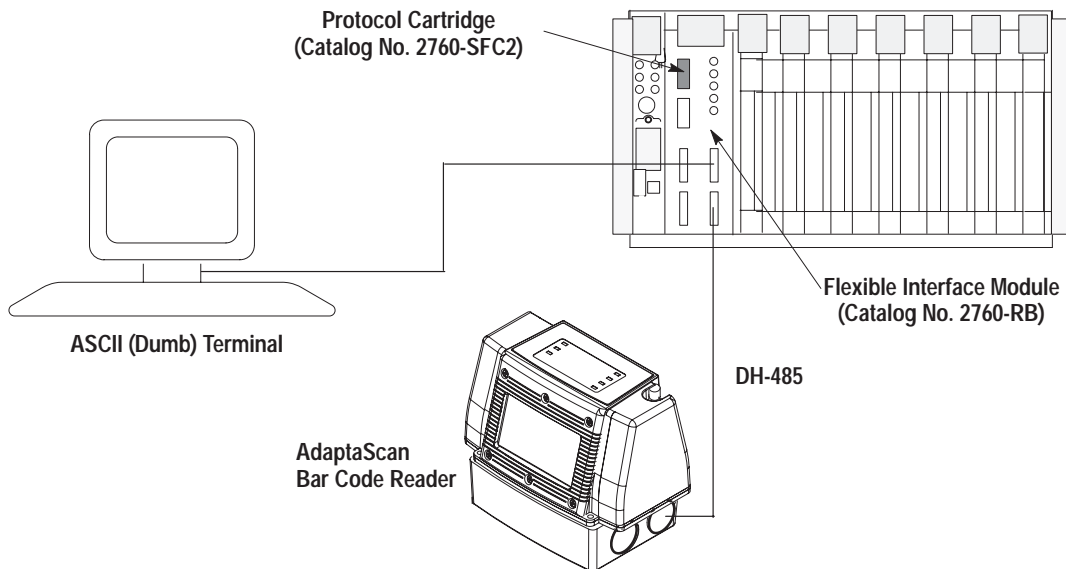

Cabling

Cable 1 must be constructed to connect a configuration terminal to the 2760-RB Module Configuration port.

Cable 2 must be constructed to connect the RS485 port of the bar code reader wiring base to Port 1 on the 2760-RB module. Refer to following cabling diagrams.

Cable 1

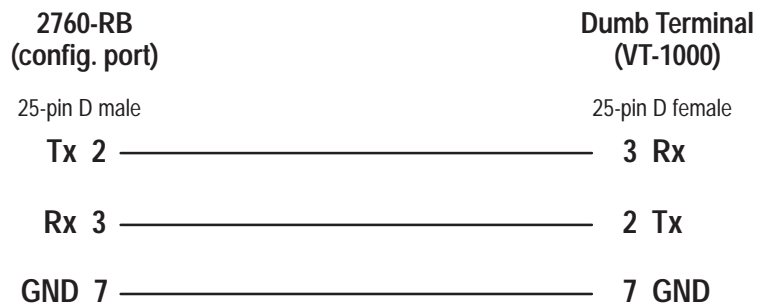

Cable 2

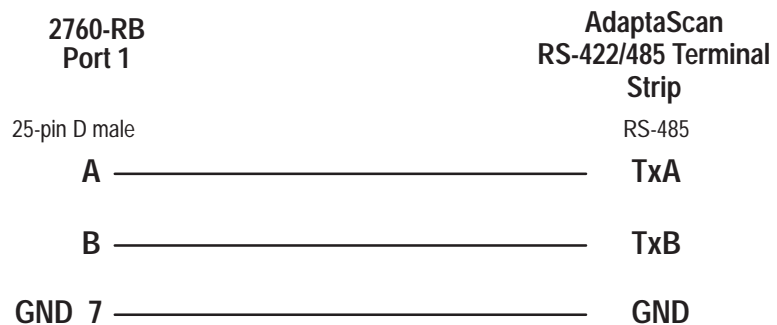

To configure the 2760-RB module:

1. Set all 2760-RB module DIP switches to Off.
2. Connect the smart cable to the Configuration port of the 2760-RB module and the serial port of the computer.
3. Send a "break sequence" to the 2760-RB module via the Terminal Emulator:
 - G. Set the baud rate to 9600, 8 data bits, 1 stop bit, no parity, no flow control, and either COM1 or COM2 depending on the smart cable connection.
 - H. Program a function key to send the "break sequence" by using the Ctrl-Shift-Break command. (This step is specifically for Windows 3.1 Terminal Emulation.)
 - I. Send the break sequence to call up the 2760-RB module configuration menu.
4. Select menu item 3: Device port protocol names. Set to:
 PORT1=COPYRIGHT 1989 ALLEN-BRADLEY COMPANY INC.
 2760-SFC2 LAN SERIES A REVISION B (YES/NO)=YES
5. Select menu item 21: Identification numbers. Select:
 RS485 LAN 2755-DM6 ASCII MODE 0H (YES/NO)=YES
6. Select option 11: Configuration parameters. Set to:
 SLOT TIME (NO. CHARS) (DEC 0 ... 255) = 15
 INTER-CHAR TIME (NO. CHARS) (DEC 0 ... 255) = 7
 IDLE TIME (NO. CHARS) (DEC 0 ... 255) = 3
 RETRIES (DEC 0 ... 255) = 3
 19,200 BITS PER SECOND (YES/NO)=YES
 BCD NODE NUMBERS (ENABLE/DISABLE)= ENABLE
 BYTE SWAPPING (ENABLE/DISABLE)=ENABLE
 RECEIVE MATRIXING (ENABLE/DISABLE)=DISABLE
 MATRIX ADDRESS (HEX 0 ... FFFF) = 0
 RE-ESTABLISH FREQUENCY (DEC 0 ... 255)=5
 POLL FREQUENCY/DESTINATION [0] (HEX 0 ... FFFF)=5
 POLL FREQUENCY/DESTINATION [1] (HEX 0 ... FFFF)=105
 POLL FREQUENCY/DESTINATION [2] (HEX 0 ... FFFF)=5
 POLL FREQUENCY/DESTINATION [3] (HEX 0 ... FFFF)=5

Type save or quit to exit out of the editor.

7. Verify that the 2760-RB is in chassis 0, group 0 module 0.
8. Save the above configuration.

Configuring the Bar Code Reader

This section shows how to configure the AdaptaScan Bar Code Reader (with v7.1 firmware or later) using the AdaptaScan Software (Catalog No. 2755-ASN).

The procedures in this section show how to:

- define the DeviceNet node address of the AdaptaScan reader
- configure a bar code label and symbol
- configure the scanner
- configure the decoder trigger
- configure the serial port
- configure the format of messages and the message destination

The steps may vary for some procedures because of the different requirements of applications. For example, the bar code labels may vary from one application to the next.

Create a New Project

Create a new project named Downloading Match Code for the AdaptaScan Bar Code Readers.

1. Choose New from the Project menu to create a new project.
2. Click the New button to add a bar code reader to the project.

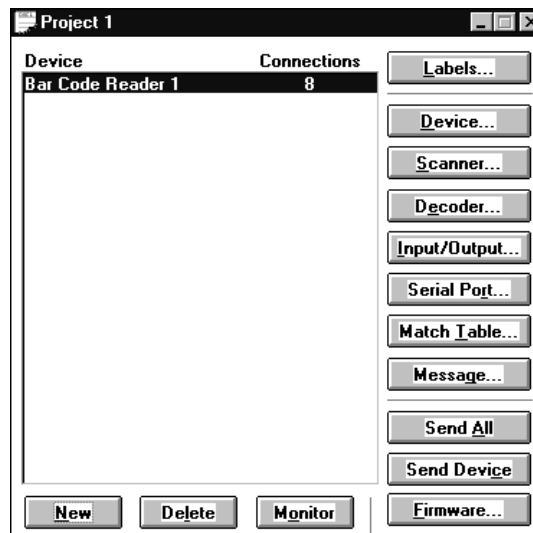

3. Choose Edit from the Project menu to rename the project
Downloading Match Code.

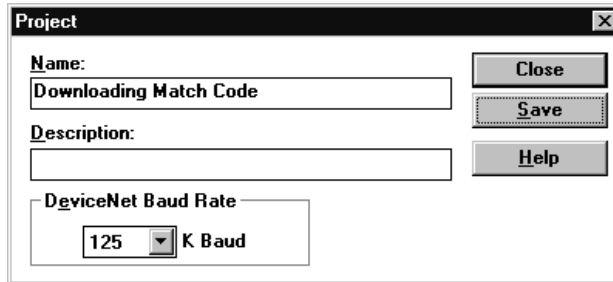

4. Click Save to save the project under the new name and then Close to return to the Project dialog.

Define the Bar Code Label

1. Click the Labels button to open the Bar Code Labels dialog.
2. Click the New button to define a label.



3. Click the New button to define a symbol for the label.

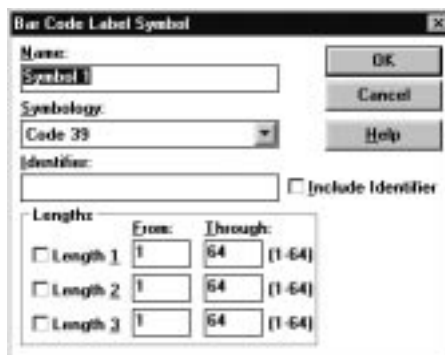

4. Select a symbology and any other parameters (Identifier, Lengths) required by your application.
5. Click OK until you return to the Bar Code Labels dialog.
6. Click Save and then Close to return to the main Project dialog.

Define the DeviceNet Address

1. Click the Device button on the Project dialog.

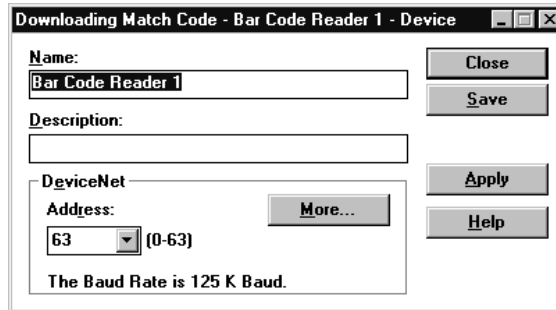

2. Set the DeviceNet address to **63**.

Note: The DeviceNet address is not always the same as the DH-485 node address. A DH-485 node address is assigned later.

3. Connect the 2755-NC43 or -NC48 Configuration Cable to the reader.
4. Click the Apply button.
5. Click Save and Close to return to the Project dialog.

Configure the Scanner

1. Click the Scanner button on the Project dialog to open the Scanner dialog.

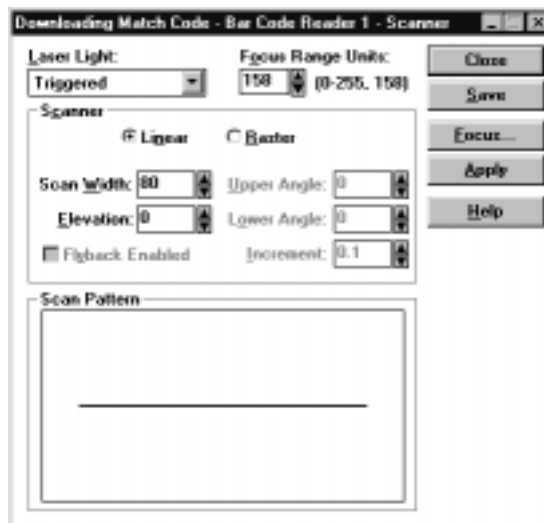

2. Configure the scan pattern and use the Focus procedure for optimum scanner focus.
3. Click the Close button and return to the Project dialog.

Configure the Decoder Trigger

This application uses a Timer to trigger the reader's decoder. The Timer is typically used during application setup. Refer to the *AdaptaScan Bar Code Readers User Manual* (Publication No. 2755-837) for other input sources that trigger the decoder.

1. Click the Decoder button from the main Project dialog.
2. Under Triggered By, select **Timer** from the Input list.



3. Click the Save button.
4. Click the Close button and return to the main Project dialog.

Configure the Serial Port

1. Click the Serial Port button from the Project dialog.

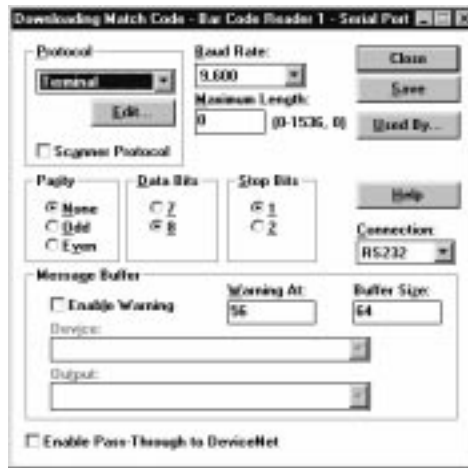

2. Configure the serial port as follows:
 - Check (enable) the Scanner Protocol check box
 - From the Protocol list box, select **DH-485**
 - From the Baud Rate list box, select **19,200**
 - From the Connection list box, select **RS485**

The configuration must match the host configuration.

3. Click the Edit button under Protocol to edit the DH-485 parameters.

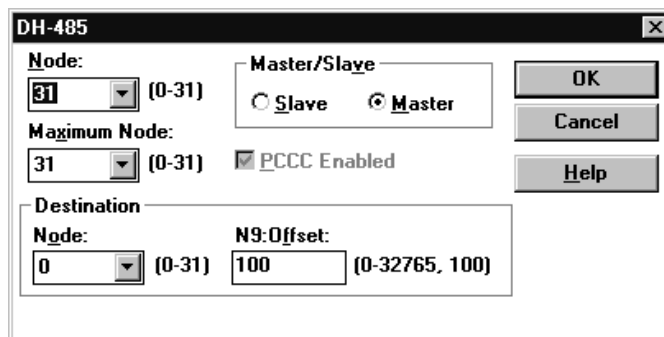

Edit the parameters as follows:

- Select **Slave** under Master/Slave
 - From the Node list box, select **2**
This is the node address of the reader on the network.
4. Click OK to return to the Serial Port dialog.
 5. Click Save and then Close to return to the main Project dialog.

Configure for Match Codes

1. Click the Match Table button to open the Match Table dialog.

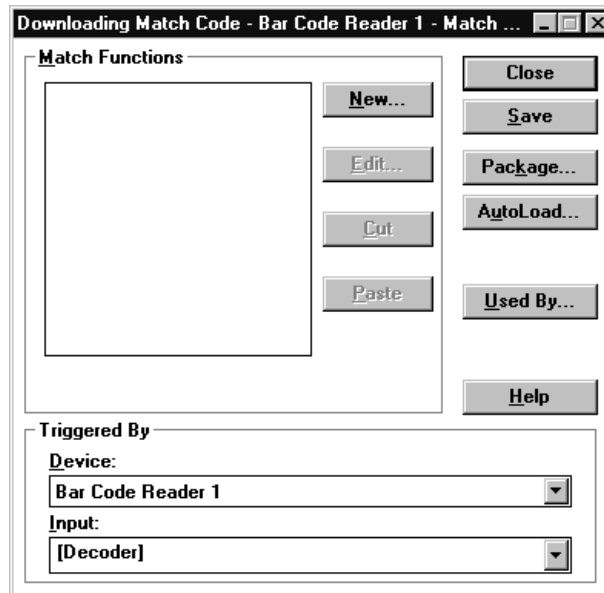

2. Click the New button to open the Match Function dialog and create a Match Function.

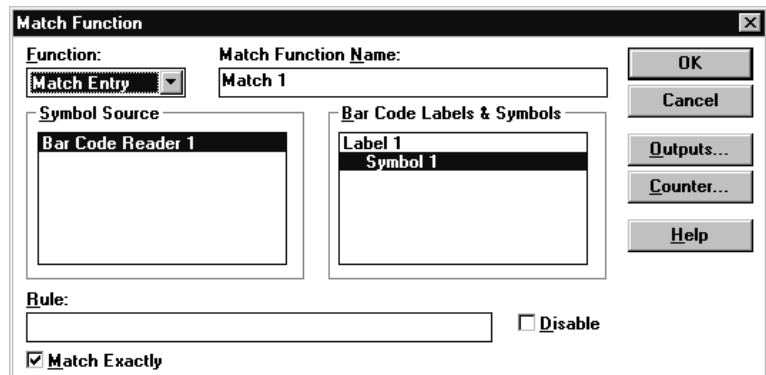

3. Under Function, select **Match Entry**.
Match Entry specifies that a match occurs whenever decoded bar code data matches the Rule: entry.
4. Under Symbol Source, select **Bar Code Reader 1**.
5. Under Bar Code Labels and Symbols, select **Symbol 1**.
6. Click the Match Exactly box.
Match Exactly specifies that ASCII characters are matched instead of a metacharacter rule.

- Click the Outputs button to specify which output activates when a match occurs.

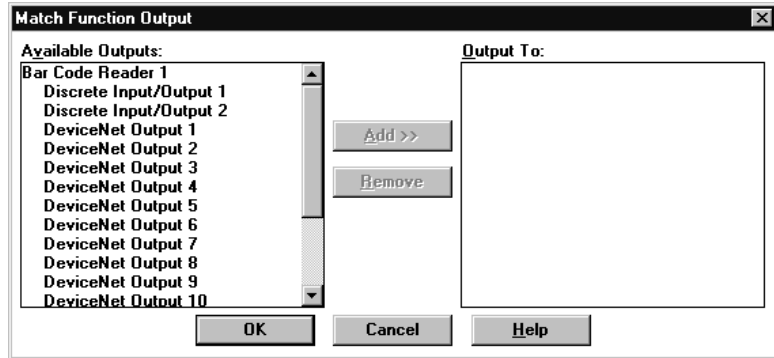

- Under Available Outputs, select **Discrete Input/Output 1**.
- Click the Add>> button to add this selection to the Output To: area.
- Click OK to return to the main Match Table dialog.

Configure for a Package

- Click the Package button to open the Package dialog.

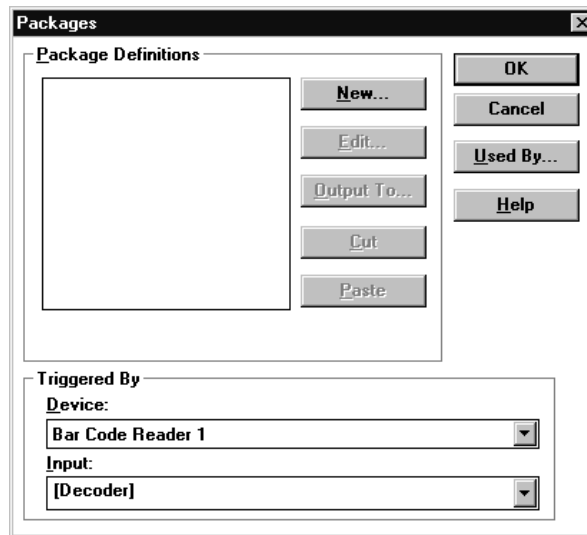

- Click the new button to create a Package.
- Under Mode, select **No-Read or No-Match**.
This mode is used to determine when a label is not read or does not match the rule defined in the Match function.
- Highlight Match 1 to enable the Match function.
- Click OK to return to the main Package dialog.

Configure for an Output

1. Click the Output To button to specify which output activates when a No-Read or No-Match occurs.

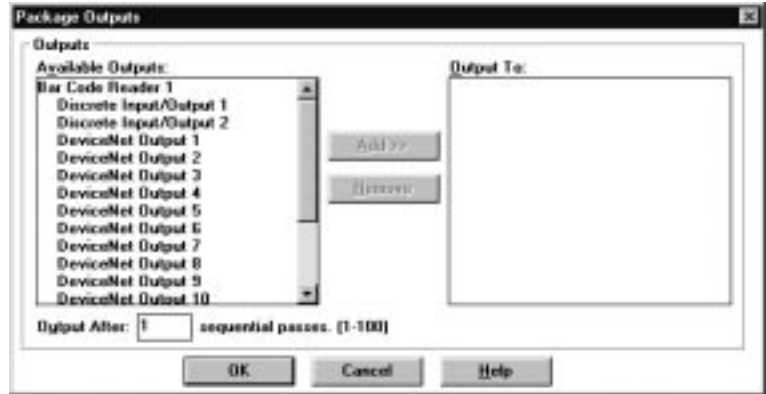

2. Under available Outputs, select **Discrete Input/Output 2**.
3. Click the Add>> button to add this selection to the Output To: area.
4. Click OK to return to the main Match Table dialog.
5. Click Save and Close to return to the main Project dialog.

Sending the Configuration to the Reader

From the main Project dialog, click the Send Device button to download the configuration to the bar code reader.

Use the Monitor dialog to verify the decoding of bar code labels.

Downloading Match Codes

To download match codes from the RB module you must:

1. Use PLC command files to send the match codes.
2. Convert the match string to hex.
3. Send the data packet (containing the string) to the reader.

PLC Command Files

Description	Word Offset	High Byte No.	Low Byte No.
Byte count length. Use the BCD/HEX screen to enter the byte count length.	0	00	18
Source 05 and destination is 01. Refer to <i>Bulletin 2760 RS-485 LAN Master/Slave Protocol User's Manual</i> (Publication No. 2760-822) for more information.	1	05	01
LSAP equals 80 and DH485 Node equals 1. Refer to <i>Bulletin 2760 RS-485 LAN Master/Slave Protocol User's Manual</i> (Publication No. 2760-822) for more information.	2	80	01
Data packet	3	Data	Data
Data packet	4	Data	Data

Convert the Bar Code String to Hex

Convert the bar code string you want to send to the reader to the hexadecimal ASCII equivalent value. For example:

Bar Code String:

0	3	0	0
---	---	---	---

Converted Hex Value:

30	33	30	30
----	----	----	----

Converted Bar Code Length Value:

0	4	0	0
---	---	---	---

In the bar code length value shown above, if the number of characters 04 were changed to 14, the hexadecimal value would be 0E. This hexadecimal value is written as 0E00.

Place the String in the Data Packet

The bar code string is sent in a data packet having this format:

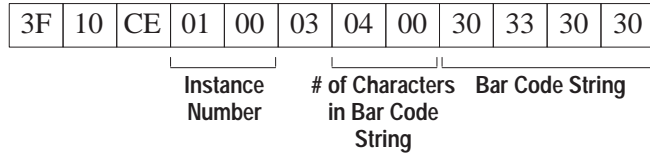

The following are descriptions of the data packet:

- 3F = DeviceNet Address (3F= 63, each reader has unique address)
- 10 = Set attribute (single request)
- CE = 206 = Class (always 206 for match table)
- 01 = Instance Number (LSB)
- 00 = Instance Number (MSB)
- 03 = Attribute Number – Rule
- 04 = Length of String (LSB)
- 00 = Length of String (MSB)
- 30 = ASCII “0”
- 33 = ASCII “3”
- 30 = ASCII “0”
- 30 = ASCII “0”

Note: You can use the Windows calculator to convert decimal values to hexadecimal.

Match Code String in Block Transfer Write

Word 0	0	1	2	3	4	5	6	7	8
N7:400	0018	0501	8001	3F10	CE01	0003	0400	3033	3030

The response of 3F90 indicates a good write of the match code.



Note: If you want to view the data after you have received the response 3F90, set up the OLP message screen. Once the message is setup, the response code will be overwritten by the bar code data.

Note: Refer to the next page for a description of the response code format and codes.

You can verify whether or not a correct match code was downloaded by placing a bar code label in front of the reader so that it is scanned. Observe the Output #1 LED on the top of the reader. When the downloaded match code matches a scanned label, the output will turn on.

If you receive a response code other than 90, refer to the the response code chart below.

Response Codes

Response codes have the following format:

Byte	Contents
0	Mac ID (Address)
1	94 = Error Response
2	x = General Error Code
3	x = Additional Code

General Error Codes

Code (hex)	Name
02	Resource unavailable
08	Service not supported
09	Invalid attribute value
0B	Already in requested mode/state
0C	Object cannot perform service in its current mode/state
0E	Attribute not settable
0F	Access permission does not allow service
10	Device's mode/state does not allow object to perform service
11	Reply data too large
13	Not enough data
14	Attribute not supported
15	Too much data
16	Object does not exist
18	No stored attribute data
19	Store operation failure
D0-FF	Class specific

Communicating with AdaptaScan Bar Code Readers via DeviceNet Peer-to-Peer Protocol

Overview

This application describes how to connect and configure AdaptaScan Bar Code Readers to communicate with each other over a DeviceNet network via peer-to-peer protocol.

The DeviceNet network has three nodes, each made up of an AdaptaScan Bar Code Reader. Each reader:

- is configured the same,
- sends a different symbol to a designated serial port on any one of the readers,
- is triggered by its own package detect unit, and
- is powered by its own power supply.

Hardware Requirements

The hardware items required for this application are:

- 2755-SN3, -SN5 or -SN8 AdaptaScan Bar Code Reader
- 2755-NB40 or -NB41 Wiring Base
- 2755-PW46 or -PW47 Power Supply (if not power by DeviceNet)
- 2755-NC43 or -NC48 Configuration Cable
- DeviceNet trunk cable
- Computer running Windows 3.1 (or later) or Windows 95
- 9-to-25 Pin Adapter (for Computer with 25-pin COM port)

Software Requirement

The 2755-ASN AdaptaScan Offline Programming Software (v8.0 or later) is the only software requirement for this application.

Related Publications

Related publications include:

Publication	Description
2755-837	AdaptaScan Bar Code Readers User Manual
2755-838	AdaptaScan Software User Manual

Connecting to the DeviceNet Network

The following illustration shows the nodes of the DeviceNet peer-to-peer network. Peer-to-Peer communications allows a single reader to gather data from the other readers over a DeviceNet network. The reader then transfers the data to the computer over an RS-232 link.

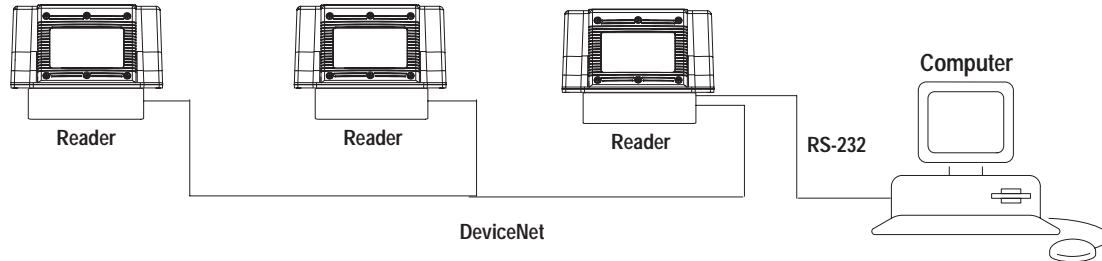

Connecting a Power Supply to a Reader

In the illustration the next page, each reader is powered by a separate Catalog No. 2755-PW46 or -PW47 power supply. The Catalog No. 2755-PW46 is shown. Do not connect power supplies in parallel.

Use a shielded cable (Belden 9316 recommended) when making power connections.

Note: You must ground V- to Earth Ground at a single point on the power supply link, preferably as near the power supply as possible.

Ensure that the V+ lines are not connected together and that the V- lines are connected together as shown on top of next page.

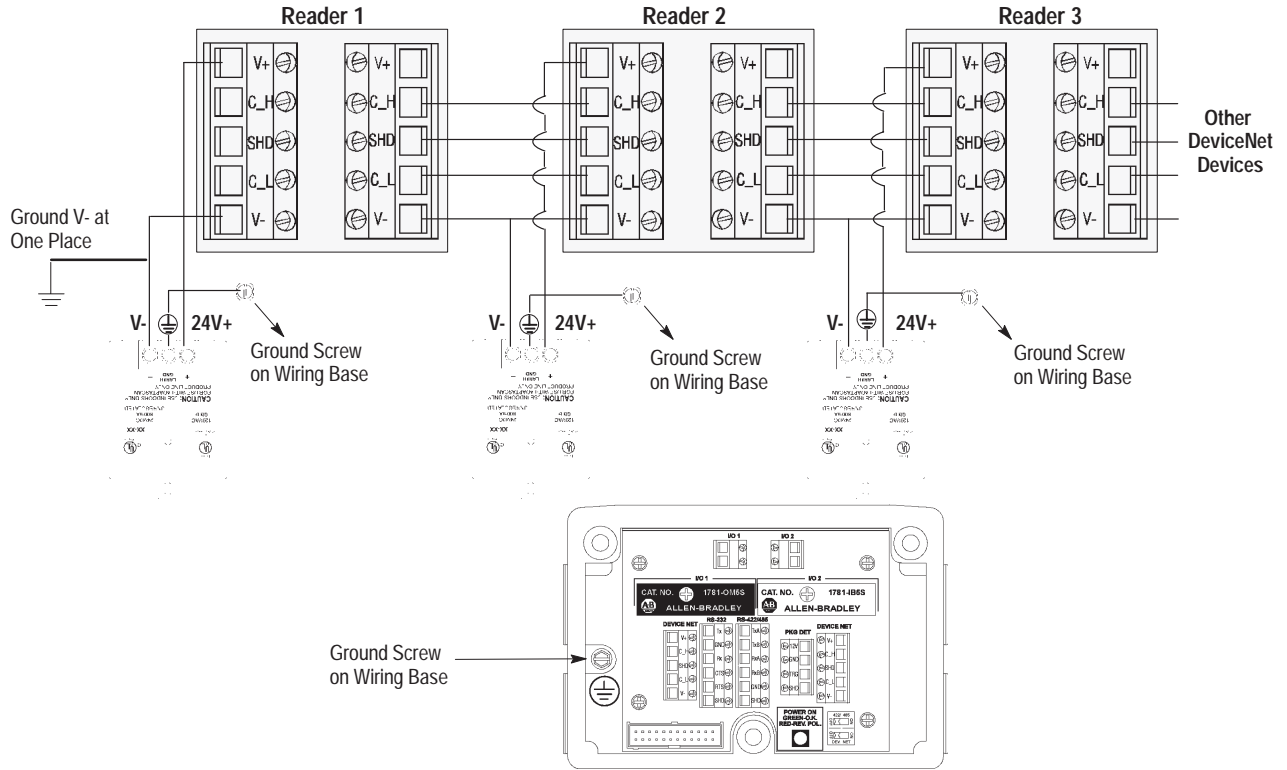

See *DeviceNet Cable System Planning and Installation Manual* (Publication No. DN-6.7.1) for recommendations and accessories.

Multiple Reader Connections using Other Power Supply

Below all readers are powered by another power supply. Use a linear unregulated power supply. The supply must provide 14 watts of power to each reader. Use a shielded cable (Belden 9316 recommended) when making power connections.

Note: You must ground V- to Earth Ground at a single point on the power supply link, preferably as near the power supply as possible.

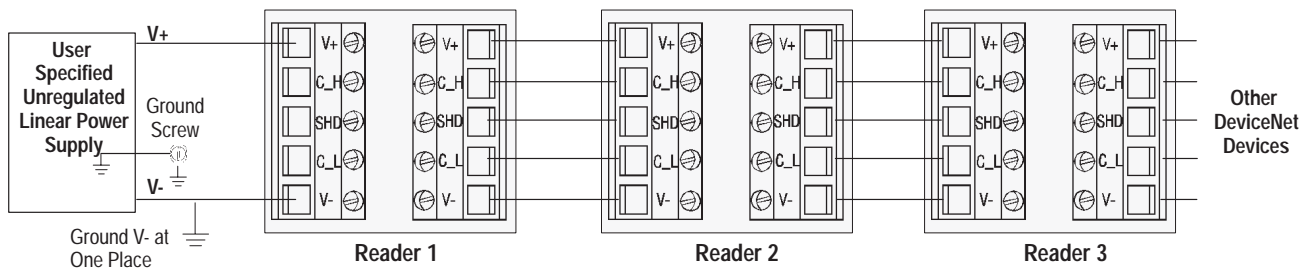

See *DeviceNet Cable System Planning and Installation Manual* (Publication No. DN-6.7.1) for recommendations and cable accessories.

Configuring Bar Code Reader 1

This section shows how to configure one the AdaptaScan Bar Code Readers using the AdaptaScan Software (Catalog No. 2755-ASN).

The procedures in this section show how to:

- define the DeviceNet node address of the AdaptaScan Reader
- configure a bar code label and symbol
- configure the scanner
- configure the decoder trigger
- configure the serial port
- configure the format of messages and the message destination

The steps may vary for some procedures because of the different requirements of applications. For example, the bar code labels may vary from one application to the next.

Create a New Project

This section adds three bar code readers to a new project and then renames the project DeviceNet Peer-to-Peer.

1. Choose New from the Project menu to create a new project.
2. Click the New button three times to add three bar code readers (Bar Code Reader 1, Bar Code Reader 2, Bar Code Reader 3) to the project.

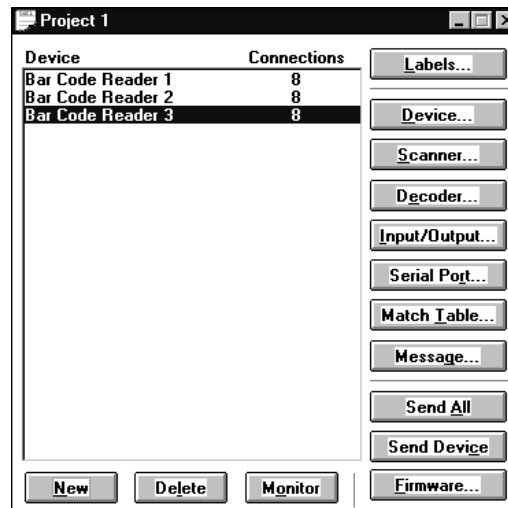

3. Choose Edit from the Project menu to rename the project **DeviceNet Peer-to-Peer**.

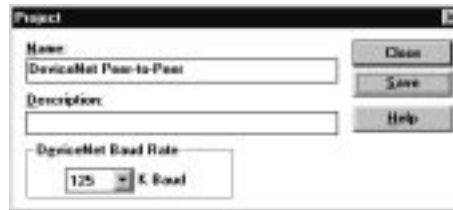

4. Click Save to save the project under the new name and then Close to return to the Project dialog.

Define the DeviceNet Address

1. Select Bar Code Reader 1 from the Project dialog.
2. Click the Device button on the Project dialog.



3. Set the DeviceNet address to 1.
4. Connect the 2755-NC43 or -NC48 Configuration Cable to Reader 1.
5. Click the Apply button.
6. Click Save and Close to return to the Project dialog.

Define the Bar Code Label

This section defines the bar code label used by the application. Each reader will scan/decode a different symbol. The 3 symbols are UPC-A, Interleaved 2 of 5, and Code 39.

1. Click the Labels button to open the Bar Code Labels dialog.
2. Click the New button to define a label.

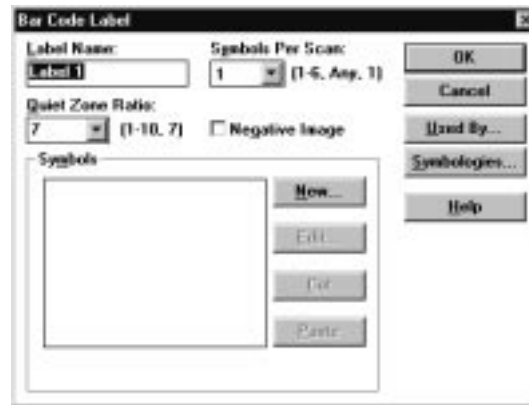

3. Click the New button to define Symbol 1.

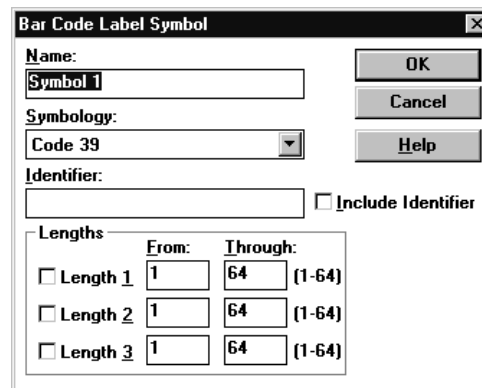

4. From the Symbology list box, select **UPC-A**.
To edit parameters of the selected symbology, click the Symbologies button.
5. Click OK to return to the Bar Code Label dialog.
6. Click the Labels button to open the Bar Code Labels dialog.
7. Click the New button to define label 2.
8. Click the New button to define Symbol 1.
9. From the Symbology list box, select **Interleaved 2 of 5**.
To edit parameters of the selected symbology, click the Symbologies button.

10. Click OK to return to the Bar Code Label dialog.
11. Click the Labels button to open the Bar Code Labels dialog.
12. Click the New button to define label 3.
13. Click the New button to define Symbol 1.
14. From the Symbology list box, select **Code 39**.

To edit parameters of the selected symbology, click the Symbologies button.

Configure the Scanner

1. Click the Scanner button on the Project dialog to open the Scanner dialog.



2. Configure the scan pattern and use the Focus procedure for optimum scanner focus.
3. Click the Close button and return to the Project dialog.

Configure the Decoder Trigger

Bar Code Reader 1 is triggered by its own package detect device. Refer to Publication No. 2755-837 for other input sources that trigger the decoder.

1. Click the Decoder button from the main Project dialog.



2. Under Triggered By, select **Package Detect** from the Input list.
3. Click the Save button.
4. Click the Close button and return to the main Project dialog.

Configure the Serial Port

Configure the parameters of the serial port to match the host device.

1. Click the Serial Port button from the main Project dialog.

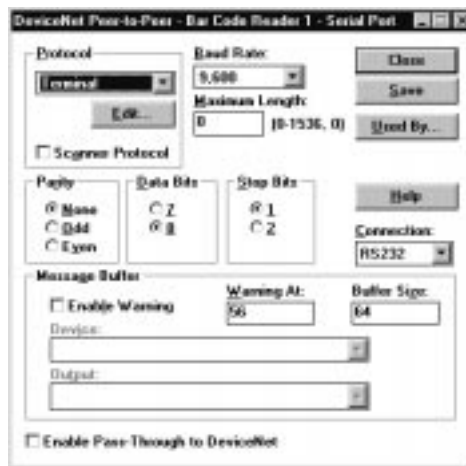

2. Verify that the serial port settings match the host device.
3. Click Save and then the Close button to return to the Project dialog.

Create a Message

This section defines the content of messages sent by Bar Code Reader 1 to the host device over an RS-232 link.

1. Click the Message button from the main Project dialog.



2. Under Triggered By, check the Enable check box.
3. Under Device, select **Bar Code Reader 1**.
4. Under Input, select **[Decoder]**.
5. Click the New button to open the Message Field.

This dialog defines the source and type of message.



6. Under Symbol Source, select **Bar Code Reader 1**.
7. Under Bar Code Label & Symbols, select **Symbol 1**.

Bar Code Reader 1 only reads UPC-A labels (per the Label 1 definition).

8. Check (enable) the Match Exactly check box.
9. Click the Edit button to open the Message Field Edit dialog.



10. Under Replacement Strings, type **no read** in the Fail: box.
Bar code data is sent to the host on a valid read. The Fail string sends “no read” to the host when a no read occurs on Bar Code Reader 1.
11. Click OK to return to the Message Field dialog.
12. Click OK again to return to the Message dialog.

Define the Message Format

1. Click the Format button from the Message dialog.



2. In the Trailer text box, type `\r\n` (for CR, LF).
3. Verify that the Field Data check box (under Include) is checked.
4. Under Message Destination, select **Serial Port**.
Data is sent from the serial port of Bar Code Reader 1 to the host device over an RS-232 link.
5. Click OK to return to the Message dialog.
6. Click Save and then Close to return to the Project dialog.

Configuring Bar Code Reader 2

This section shows how to configure Bar Code Reader 2 on the DeviceNet network.

Select Bar Code Reader 2 in the Project

From the Project dialog, select **Bar Code Reader 2**.



Define the DeviceNet Address

1. Click the Device button on the Project dialog.



2. Set the DeviceNet address to **2** for the configuration download.
3. Connect the 2755-NC43 or -NC48 Configuration Cable to Reader 2.
4. Click the Apply button.
5. Click Save and Close to return to the Project dialog.

Configure the Scanner

1. Click the Scanner button on the Project dialog to open the Scanner dialog.



2. Configure the scan pattern and use the Focus procedure for optimum scanner focus.
3. Click the Close button and return to the Project dialog.

Configure the Decoder Trigger

Bar Code Reader 2 is triggered by its own package detect device. Refer to Publication No. 2755-837 for other input sources that trigger the decoder.

1. Click the Decoder button from the main Project dialog.



2. Under Bar Code Label, select **Label 2**.
3. Under Triggered By, select **Package Detect** from the Input list.
4. Click the Save button.
5. Click the Close button and return to the main Project dialog.

Create a Message

This section defines the content of messages sent by Bar Code Reader 2 to the host device.

1. Click the Message button from the main Project dialog.



2. Under Triggered By, check the Enable check box.
3. Under Device, select **Bar Code Reader 1**.
4. Under Input, select [**Decoder**].
5. Click the New button to create a message field.

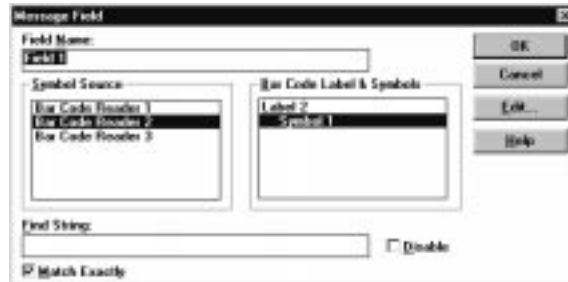

6. Under Symbol Source, select **Bar Code Reader 2**.
7. Under Bar Code Label & Symbols, select **Symbol 1**.

Bar Code Reader 2 reads Interleaved 2 of 5 labels (per the Label 2 definition).

8. Check (enable) the Match Exactly check box.

- Click the Edit button to open the Message Field Edit dialog.

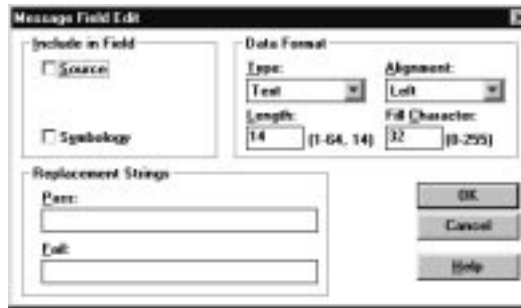

- Under Replacement Strings, type **no read** in the Fail: box.
Bar code data is sent to the host on a valid read. The Fail string sends “no read” to the host when a no read occurs on Bar Code Reader 2.
- Click OK to return to the Message Field dialog.
- Click OK again to return to the Message dialog.

Define the Message Format

- Click the Format button from the Message dialog.



- In the Trailer text box, type `\r\n` (for CRLF).
- Verify that the Field Data check box (under Include) is checked.
- Under Message Destination, select **Serial Port** and **Bar Code Reader 1** from the list box.

Data is sent to the host device through the serial port of Bar Code Reader 1.

- Click OK to return to the Message dialog.
- Click Save and then Close to return to the Project dialog.

Configuring Bar Code Reader 3

This section shows how to configure Bar Code Reader 3 on the DeviceNet network.

Selecting Bar Code Reader 3 in the Project

From the Project dialog, select **Bar Code Reader 3**.



Define the DeviceNet Address

1. Click the Device button on the Project dialog.



2. Set the DeviceNet address to **3** for the configuration download.
3. Connect the 2755-NC43 or -NC48 Configuration Cable to Reader 3.
4. Click the Apply button.
5. Click Save and Close to return to the Project dialog.

Configure the Scanner

1. Click the Scanner button on the Project dialog to open the Scanner dialog.



2. Configure the scan pattern and use the Focus procedure for optimum scanner focus.
3. Click the Close button and return to the Project dialog.

Configure the Decoder Trigger

Bar Code Reader 3 is triggered by its own package detect device. Refer to Publication No. 2755-837 for other input sources that trigger the decoder.

1. Click the Decoder button from the main Project dialog.



2. Under Bar Code Label, select **Label 3**.
3. Under Triggered By, select **Package Detect** from the Input list.
4. Click the Save button.
5. Click the Close button and return to the main Project dialog.

Create a Message

This section defines the content of messages sent by Bar Code Reader 3 to the host device.

1. Click the Message button from the main Project dialog.



2. Under Triggered By, check the Enable check box.
3. Under Device, select **Bar Code Reader 1**.
4. Under Input, select **[Decoder]**.
5. Click the New button to create a message field.



6. Under Symbol Source, select **Bar Code Reader 3**.
7. Under Bar Code Label & Symbols, select **Symbol 1**.
Bar Code Reader 3 reads Code 39 labels (per the Label 3 definition).
8. Check (enable) the Match Exactly check box.

- Click the Edit button to open the Message Field Edit dialog.



- Under Replacement Strings, type **no read** in the Fail: text box.
Bar code data is sent to the host on a valid read. The Fail string sends “no read” to the host when a no read occurs on Bar Code Reader 3.
- Click OK to return to the Message Field dialog.
- Click OK again to return to the Message dialog.

Define the Message Format

- Click the Format button from the Message dialog.



- In the Trailer text box, type `\r\n` (for CRLF).
- Verify that the Field Data check box (under Include) is checked.
- Under Message Destination, select **Serial Port** and **Bar Code Reader 1** from the list box.

Data is sent to the host device through the serial port of Bar Code Reader 1.

- Click OK to return to the Message dialog.
- Click Save and then Close to return to the Project dialog.

Sending the Configurations to the Readers

From the main Project dialog, click the Send All button to download the configurations to Bar Code Reader 1, Bar Code Reader 2, and Bar Code Reader 3.

Running the Application

When the application is running, bar code data is sent from the three bar code readers and to the host device. When selected from the Message dialog, the AdaptaScan Bar Code Reader routes messages from each reader over DeviceNet to the serial port of Reader 1.

Communicating with PanelView 900™ Terminals on a DeviceNet Network

Introduction

This application describes how to connect and configure communications for the DeviceNet versions of the PanelView 900 terminals. This document provides supplemental information for the *PanelBuilder Software User Manual* (Publication No. 2711-6.0).

Hardware Requirements

The hardware items required for this application are:

- 2755-SN3, -SN5 or -SN8 AdaptaScan Bar Code Reader
- 2755-NB40 or -NB41 Wiring Base
- 2755-PW46 or -PW47 Power Supply (if not power by DeviceNet)
- 2755-NC43 or -NC48 Configuration Cable
- DeviceNet trunk cable
- 2711-K9C10, -T9C10, -K9A10, or -T9A10 PanelView 900 terminal
- 1747-L532, -L541, -L542, or -L543 SLC Processor or 1785 PLC-5 processor and appropriate chassis
- 1747-SDN Scanner Module (v2.05 firmware or later) or 1771-SDN Scanner Module (v3.04 firmware or later)
- Computer running Windows 3.1 (or later) or Windows 95
- 9-to-25 Pin Adapter (for Computer with 25-pin COM port)

Software Requirements

The software requirements for this application are:

- 2755-ASN AdaptaScan Offline Programming Software (v8.0 or later)
- PanelBuilder™ software
- 6200 Series Programming Software or SLC Advanced Programming Software
- 1787-MGR DeviceNet Manager Software (v3.0 or later)

Related Publications

Related publications include:

Publication	Description
2755-837	AdaptaScan Bar Code Readers User Manual
2755-838	AdaptaScan Software User Manual
1787-6.5.3	DeviceNet Manager Software Manual
1747-6.5.2	1747-SDN DeviceNet Scanner Configuration Manual
2711-6.0	PanelBuilder Software User Manual
2711-6.1	PanelView Operator Terminals User Manual

In addition, you may want to refer to the SLC and PLC-5 Hardware and Software User Manuals.

DeviceNet PanelView™ Terminals

The table below lists the DeviceNet versions of the PanelView terminals. The differences in the terminals relate to:

- display type (monochrome or color)
- operator input (touch screen or keypad)

The DeviceNet terminals have:

- DeviceNet communication port
- RS-232 printer/file transfer port

In addition, each terminal is available with either AC or DC power.

The characters L1 at the end of the catalog number designate a terminal with DC power (e.g., -T9A10L1).

Terminal Type	Display Type		Operator Input		Ports		Catalog Number
	Color	Monochrome	Touch	Keypad	DeviceNet	RS-232	
PV900		✓		✓	✓	✓	2711-K9A10
		✓	✓		✓	✓	2711-T9A10
	✓			✓	✓	✓	2711-K9C10
	✓		✓		✓	✓	2711-T9C10

Typical DeviceNet Network

Shown below is a typical DeviceNet network with PanelView terminals installed on two of the network drops.

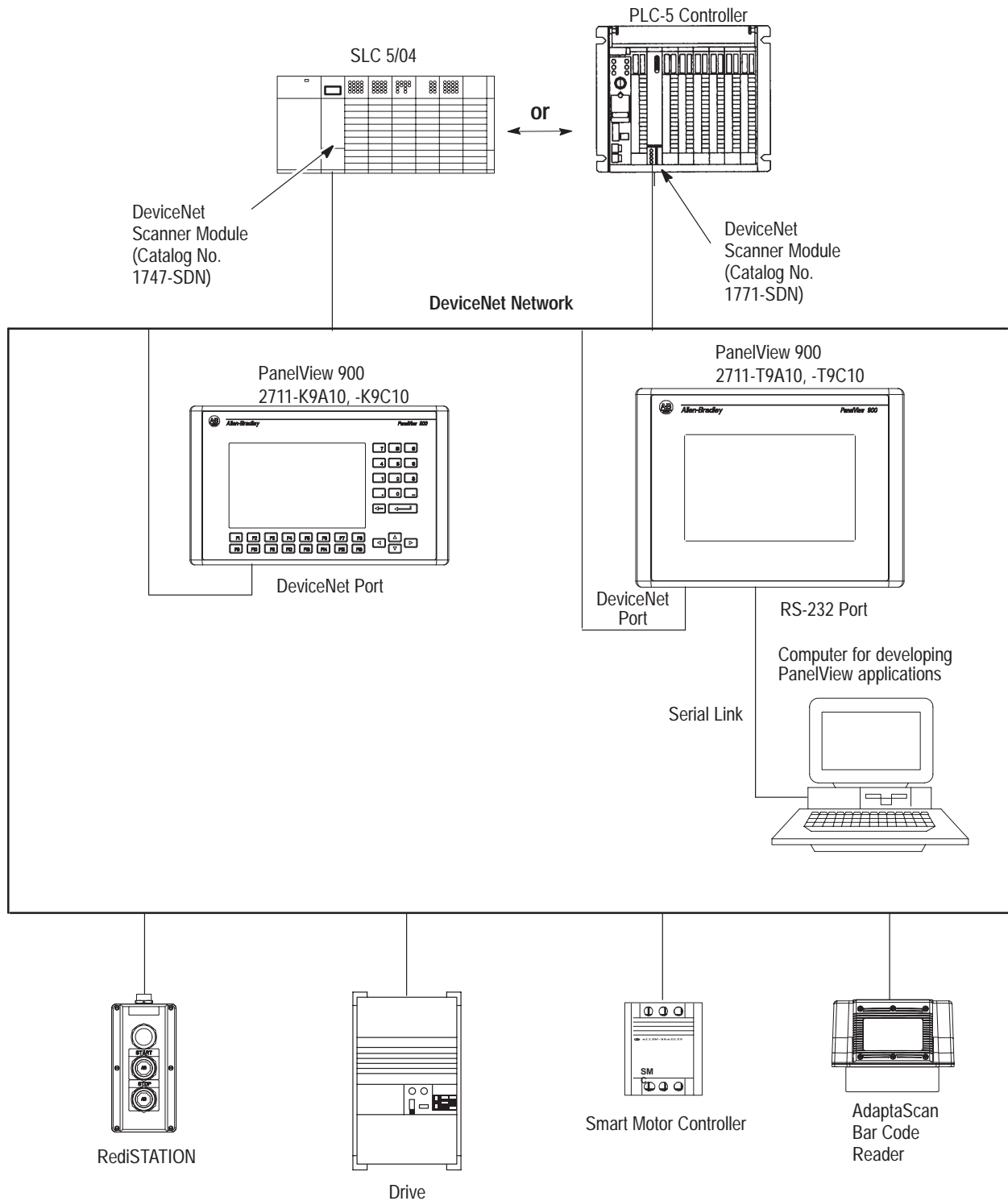

Making DeviceNet Connections

Use DeviceNet cable to connect a DeviceNet version of a PanelView terminal to a DeviceNet Network.

Cable	Catalog No.
DeviceNet Cable, 164 ft (50m)	1485C-P1A50
DeviceNet Cable, 328 ft (100m)	1485C-P1A150
DeviceNet Cable, 492 ft (150m)	1485C-P1A300

Important: Refer to the *DeviceNet Cable System Planning and Installation Manual* (Publication No. 1485-6.7.1) for network layout and design information.

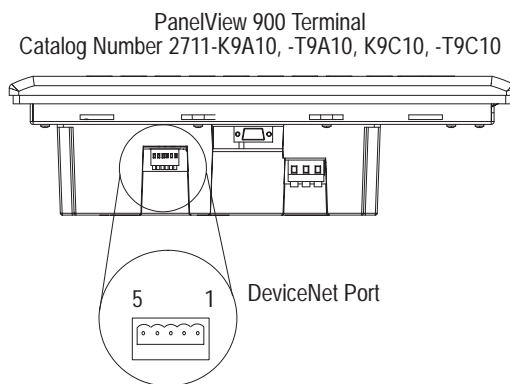

DeviceNet Terminal Block	Terminal	Signal	Function	Color
	1	COM	Common	Black
	2	CAN_L	Signal Low	Blue
	3	SHIELD	Shield	Uninsulated
	4	CAN_H	Signal High	White
	5	VDC+	Power Supply	Red

Making Serial Port Connections

Use the RS-232 serial port on the DeviceNet terminal to:

- download/upload applications over a serial link
- or to connect a printer

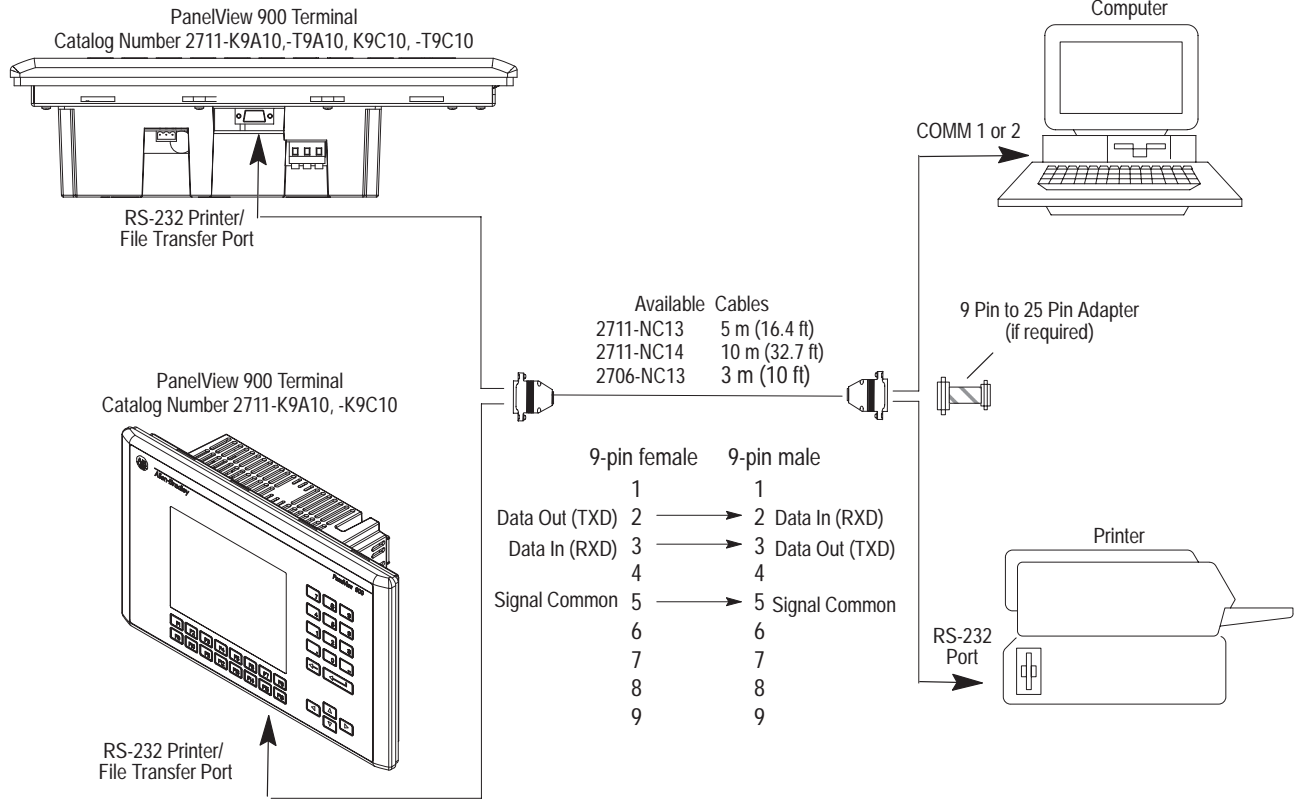

Modifying DeviceNet Settings from the Terminal

You can display or modify DeviceNet settings directly from the terminal. From the Configuration Mode menu of the terminal, select Serial Communication Setup. The screen below appears.



ATTENTION: Settings downloaded with a DeviceNet application have priority over terminal settings. DeviceNet settings take effect immediately after an application is downloaded.

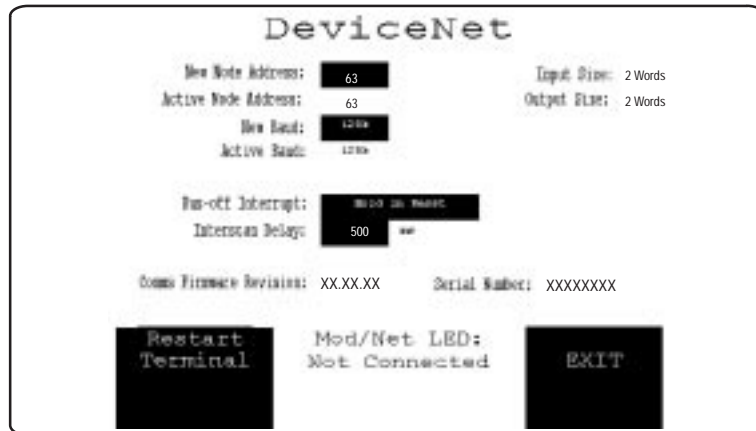

PV900 Touch Screen shown
Other displays are similar

Restart Terminal [F1]

Resets the terminal.

New Node Address [F2]

Opens the numeric entry scratchpad. Enter the node address (0 - 63) of the PanelView terminal on the DeviceNet link and press the Enter key. A node address change takes effect on reset.

Active Node Address

Displays the current network operating address of the PanelView.

New Baud [F3]

Step through the available baud rates with each key press. The options are 125K, 250K and 500K (default is 125K). The selected baud rate takes effect after a reset. The maximum cable length is restricted at higher baud rates.

Active Baud

Displays the current baud rate setting of the PanelView. The baud rate is set to the value for New Baud on power up.

Note: The active baud is the baud rate of the PanelView not the network. The PanelView is not automatically set to the network baud rate.

Bus-off Interrupt [F4]

Specify what occurs when a CAN bus-off interrupt occurs on the DeviceNet network. The PanelView is not allowed network access when Hold in Reset is selected and a bus-off interrupt occurs.

- **Hold in Reset** holds the PanelView and waits for communications to be reset or a reset of the terminal.
- **Reset and Continue Communications** resets DeviceNet communications and attempts to re-establish the communications link.

Interscan Delay [F5]

Opens the numeric entry scratchpad. Provide a delay between scans of the Explicit-Client tags. Enter a value of 0 to 65535 milliseconds. This time delay is inserted between each full scan of the Explicit-Client tags in the current screen context. This value is originally set by the downloaded application file but may be changed by an operator. When changed, the new value takes effect immediately.

Input Size

Displays the number of words (from 0 to 64) that are sent by the PanelView in an I/O message. 0 is the default value which indicates that no input data is exchanged with the scanner. This value is set by the downloaded application.

Output Size

Displays the number of words (from 0 to 64) that are received by the PanelView in an I/O message. 0 is the default value which indicates that no output data is exchanged with the scanner. This value is set by the downloaded application.

EXIT

To return to the Configuration Mode menu, press the Exit button.

COMM LED

Pattern	Indicates
Solid Fill	Normal operating state
Blinking	No communications established
No Fill	Hardware failure

Setting up Communications using PanelBuilder

Setting up DeviceNet communications for an application includes:

- selecting a DeviceNet terminal when creating the application.
- configuring communication parameters for the terminal on the DeviceNet link.

Selecting a DeviceNet PanelView Terminal

Select a DeviceNet terminal for a PanelView application from:

- New Application dialog when creating a new application or
- Terminal Setup dialog when converting the application created for another terminal.

Any catalog number with 10 as the last number is a DeviceNet terminal.

The following PanelView terminals are available with a DeviceNet port.

Catalog No.	PV Type	Color	Keypad
2711-K9C10	PV900C	Color	Keypad
2711-T9C10	PV900C	Color	Touch
2711-K9A10	PV900M	Mono	Keypad
2711-T9A10	PV900M	Mono	Touch

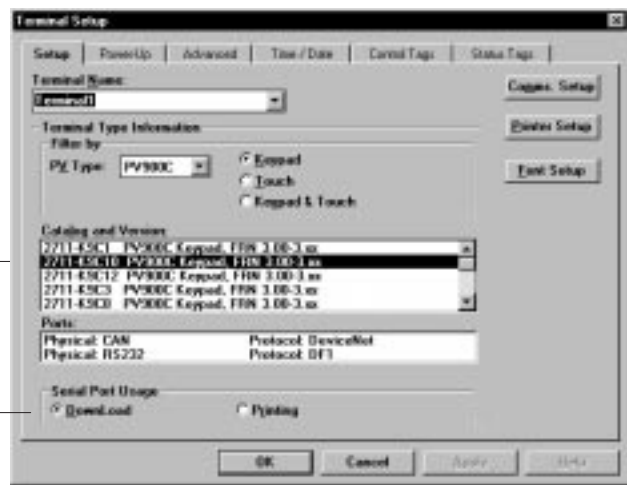
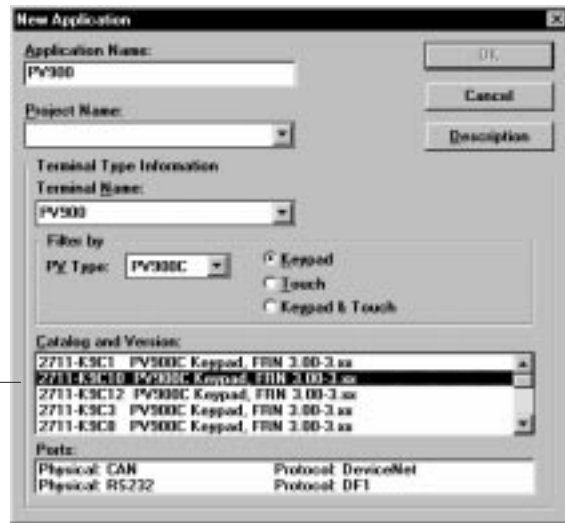

Indicates the RS-232 port is set for downloading applications.

Configuring DeviceNet Communications

DeviceNet communication parameters are accessed from the Terminal Setup dialog. To open the Terminal Setup dialog, choose Terminal Setup from the PanelBuilder Application menu.

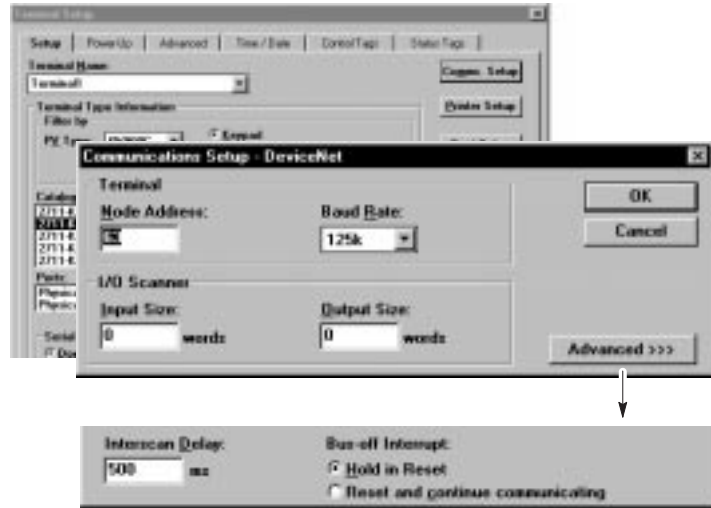

7. Click the Comms. Setup button from the Terminal Setup dialog.
8. Under Terminal, edit the following parameters:

Specify	To
Node Address	Select the address (0 to 63) of the PanelView terminal on the DeviceNet link.
Baud Rate	Select the baud rate of the DeviceNet link. The available baud rates are: 125 kbps 250 kbps 500 kbps

9. Under I/O Scanner, edit the following parameters:

Specify	To
Input Size	Specify the number of words (from 0 to 64) that are sent to the scanner from the PanelView with each I/O message. 0 is the default value which indicates that no input I/O data exists in the application.
Output Size	Specify the number of words (from 0 to 64) that are received by the PanelView from the scanner with each I/O message. 0 is the default value which indicates that no output I/O data exists in the application.

10. Edit the following parameters.

Specify	To
Interscan Delay	Provide a delay between scans of the Explicit-Client tags. Enter a value of 0 to 65535 milliseconds. The default is 500 msec. This time delay is inserted between each full scan of the Explicit-Client tags in the current screen context. Note: Time delays of less than 500 msec should be carefully considered since the Explicit-Client mode will generate low priority network messaging at this interval.
Bus-off Interrupt	Specify what occurs when a Bus-off interrupt occurs on the network: Hold in Reset holds the PanelView and waits for communications to be reset. Reset and Continue Communications resets DeviceNet communications and attempts to re-establish the communications link (if possible).

11. Click Apply to save the settings.**12.** Click OK to exit and return to the Terminal Setup dialog.

PanelView Message Types

All PanelBuilder screen control or display objects are assigned a tag when an application is developed. The tag specifies an address, data type, initial value, etc. for the data assigned to the control or display object. The Tag Editor for DeviceNet objects consist of three dialogs depending upon the message type selected.

Server Explicit and I/O Slave Messaging

The PanelView can exchange data with logic controllers, motor drives, bar code readers, etc. over a DeviceNet network. The PanelView acts as a DeviceNet compliant UCMM-capable slave supporting Explicit and I/O Slave messaging. Change-of-State / Cyclic and Polled I/O modes are supported. Strobed I/O messaging is not supported by the PanelView.

The I/O slave message connections uses the pre-defined Master/Slave connection set. Exchanged data is grouped in Assembly Object instances created using the PanelBuilder tag editor. The first input instance and the first output instance are exchanged using DeviceNet's I/O slave messages with a maximum of 64 input and 64 output words exchanged. If additional instances are configured, they can only be accessed by an Explicit Messaging Client device using messages directed to the corresponding Assembly Object Instance (Class 4, Attribute 3).

Notes on Using Server Explicit and I/O Slave Messaging:

- The I/O size specified in the PanelView terminal must match the I/O size expected by the DeviceNet scanner.
- Both acknowledged and unacknowledged Change-of-State / Cyclic modes are allowed. If acknowledgement is used, no data is returned. The Polled + COS option is allowed but the polled response data and the COS data are from the same assembly.
- The PanelView has only one general purpose Explicit message connection available at a time to an external client device. Be aware of this limitation when creating applications requiring multiple Explicit message server connections to a PanelView.
- Use of COS or Cyclic I/O connections is highly recommended over Polled I/O for I/O sizes in excess of 32 words.
- Whenever possible, use COS or Cyclic I/O connections to minimize network I/O traffic.

Client Explicit Messaging

The PanelView can also communicate using explicit messaging, where the PanelView initiates the connections (Client). Connections to other devices are created (using tag editor addressing) and use explicit messages to read and write values to other DeviceNet nodes. Only `Get_Attribute_Single` and `Set_Attribute_Single` commands are supported.

Output values assigned (addressed) to client objects in the current screen context (global or current screen) are scanned sequentially and data is read from the external device using `Get_Attribute_Single` requests.

Input values are sent to the external device (using a `Set_Attribute_Single` request) when a change of state is detected on that input.

Notes on Using Client Explicit Messaging:

- The devices communicating with the PanelView must have a sufficient number of available connections to support an Explicit message connection by the PanelView and any other connections required by the application. This includes a Group 2 Only Slave owned by a Group 2 Only Client such as a scanner capable of providing the UCMM service for the slave.
- Data read/written must be accessible as an externally addressable DeviceNet attribute with the `Get_Attribute_Single` / `Set_Attribute_Single` commands.
- Explicit-Client messaging is not designed for high speed communications and uses lower priority messaging on DeviceNet. I/O messaging should be used for time critical applications.



ATTENTION: Do not use Client Explicit messaging with critical control parameters or as an alternative to a hard wired emergency stop button.

- The PanelView has only one general purpose explicit message connection available at a time to an external client device. Be aware of this limitation when creating applications requiring multiple explicit message server connections to a PanelView.

The following diagram illustrates differences between message types:

I/O Slave Tags

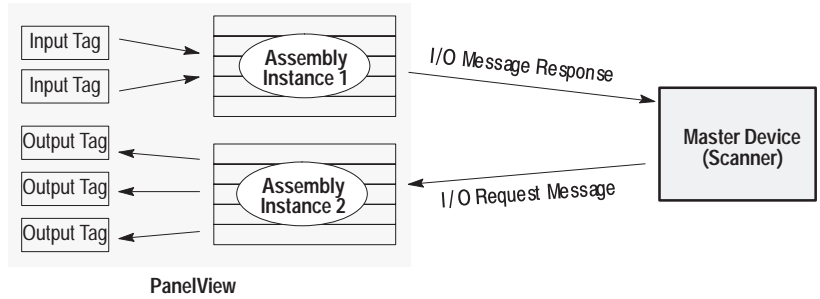

Explicit-Server Message Tags

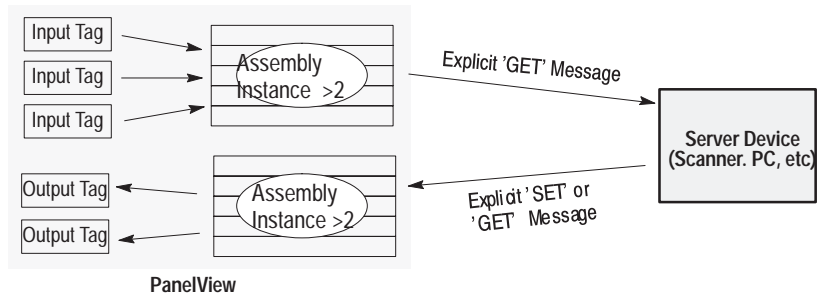

Explicit-Client Message Tags

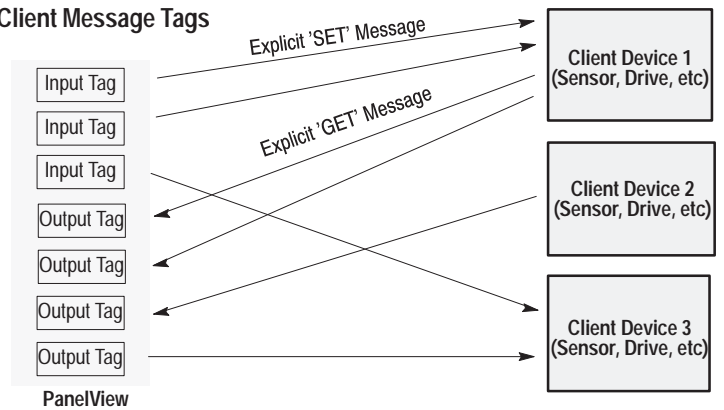

PanelView Tag Editor

Use the form view of the tag editor to enter DeviceNet tags. Do not use the table view since it does not show all of the DeviceNet fields.



I/O Slave Tag Form View



Explicit-Client Tag Form View



Explicit-Server Tag Form View

Field	Description	Valid Characters	Notes
Tag Name ^{①②}	The name of the tag	Maximum characters = 32 • A - Z, a - z, 0 - 9 • hyphen (-), underscore(_), percent (%)	<ul style="list-style-type: none"> • if you type an invalid character, the Tag Editor beeps and does not display it • the tag name must be unique within a project • cannot begin with 0 - 9, hyphen (-), or percent (%) • tag names are not case-sensitive • do not use blanks, tabs, carriage returns, non-printable characters
Data Type	The data format for the tag	Select one of the following: • bit • 4BCD • unsigned integer • signed integer • IEEE Float • bit array • character array	<ul style="list-style-type: none"> • the data type must be compatible with the data format selected in the object's dialog. <div style="display: flex; justify-content: space-around; align-items: center;"> <div style="border: 1px solid black; padding: 5px;"> <p>Object Dialog</p> <p>Write</p> <p><input type="radio"/> Single Bit</p> <p><input checked="" type="radio"/> Value</p> <p>Data Format</p> <p>Unsigned Int</p> <p>Signed Int</p> <p>4BCD</p> <p>Hexadecimal</p> </div> <div style="border: 1px solid black; padding: 5px;"> <p>Tag Editor</p> <p>Data Type</p> <p>Unsigned In</p> <p>Bit</p> <p>4BCD</p> <p>Unsigned In</p> <p>Signed Inte</p> </div> </div> <p>Alternate Methods: Type the first letter of the data type. For example, type b for the bit data type. Use the TAB key to move to the Data Type field and press ALT+↓ to display the list of available formats.</p>

Table continued on the next page.

Field	Description	Valid Characters	Notes
Swap Bytes	Only displayed when Character Array data type is selected.	Check Box	<ul style="list-style-type: none"> when selected high and low data bytes swap positions. Select swap bytes when data is sent in the wrong order (high byte first). For example, data from a PLC is sent with the first character of a string in the second byte. By swapping the bytes, the first character corresponds to the first byte. byte swapping is not generally used with Explicit-Client message types. These addressed devices will usually conform to DeviceNet specifications and send data in the correct sequence.
Swap Words	Only displayed when Float data type is selected.	Check Box	<ul style="list-style-type: none"> when selected the high and low words of a floating point value are swapped. This allows floating point values generated by a PLC to be properly displayed. word swapping is not generally required for DeviceNet devices that generate floating point values.
Message Type	Selects the message type.		additional fields are required for Explicit message types.
Instance Number (Explicit-Server Message Only)	Select an Instance from 3 to 16.	3 to 16	instances 1 and 2 are assigned to I/O message type.
Node Address (Explicit-Client Message Only)	Specifies the node address of the peer device.	0 to 63	node address range from 0 to 63.
Load from EDS (Explicit-Client Message Only)	Loads information using the Electronic Data Sheet. Refer to page 17-17.		we recommend that you load parameter data from the data sheet for the peer device. Otherwise, enter the tag information (class, instance, attribute, etc) from the sheet manually.
Write Tag (Explicit-Client Message Only)	When selected, tag is specified as a write tag (data sent to peer device).		If Write Tag is not selected, tag is specified as a read tag (data is read from peer device).
Packet Bytes (Explicit-Client Message Only)	Specifies the number of bytes in each message packet.	1 to 128	This value should match the amount of data in the attribute addressed in the external device.
Bit Offset (Explicit-Client Message Only)	Specifies the offset that indexes into the returned data. Typically this value is 0.		bit offset is limited to the number of bytes specified for the Packet Bytes (i.e. if packet bytes is 2, Bit offset must be 0-15).
Class (Explicit-Client Message Only)	Enter from device data sheet specifying the Class of the object being addressed.		recommend that you load information from electronic data sheet (EDS) automatically if possible.
Instance (Explicit-Client Message Only)	Enter from device data sheet specifying the Instance of the object being addressed.		recommend that you load information from electronic data sheet (EDS) automatically if possible.
Attribute (Explicit-Client Message Only)	Enter from device data sheet specifying the Attribute of the object being addressed.		recommend that you load information from electronic data sheet (EDS) automatically if possible.

Table continued on the next page.

Field	Description	Valid Characters	Notes
Array Size	The size of the array	<ul style="list-style-type: none"> • character arrays are 1-128 characters • bit arrays are 1-16 bits 	<ul style="list-style-type: none"> • the array size must be an integer. • do not use blanks, tabs, carriage returns, non-printable characters
Description	The description of the tag	Maximum characters = 255 <ul style="list-style-type: none"> • any printable 	<ul style="list-style-type: none"> • do not use tabs, carriage returns, non-printable characters • you can type the information in this field, or use the description editor.
Address ^{①②} (I/O Slave and Explicit-Server Messages Only)	Specifies the data sent to and from a remote device. A remote address has the following format: I: <word> / <bit> O: <word> / <bit> Note: /<bit> is required for Bit and Bit Array.	Maximum characters = 32 For more information on valid addresses, refer to your processor's user manual. <ul style="list-style-type: none"> • I specifies input data generated by the PanelView and sent to a remote device. • O specifies output data received by the PanelView from a remote device. 	do not use blanks, tabs, carriage returns, non-printable characters
Initial Value	The starting value for the current tag in engineering units (used only for write tags).	Maximum characters = 24 <ul style="list-style-type: none"> • 0 - 9 • e, E, +, - and period • if the Data Type is bit, enter either 0 or 1 	<ul style="list-style-type: none"> • do not use blanks, tabs, carriage returns, non-printable characters • maximum precision is 6 places to the right of the decimal point for non-floating point values • if present, a sign (+ or -) for the number must be first (+ is the default) • if present, a sign for the exponent must immediately follow the e or E • provides a preset value for numeric entry objects only • no entry = default of 0
Scaling ^③ Scale: 'm' in $y = mx + b$ Offset: 'b' in $y = mx + b$	The values you want to use to convert the current tag's processor integer value ('x') to engineering units ('y')	Maximum characters = 12 <ul style="list-style-type: none"> • 0 - 9 • e, E, +, - and period 	<ul style="list-style-type: none"> • do not use blanks, tabs, carriage returns, non-printable characters • maximum precision for scale is 6 places to right of decimal point • maximum precision for offset is 6 places to right of decimal point • if present, a sign (+ or -) for the number must be first (+ is default) • if present, a sign for the exponent must immediately follow the e or E
Data Entry Limits ^③ Minimum Maximum	The minimum and maximum values that can be assigned to the tag	Maximum characters = 12 <ul style="list-style-type: none"> • 0 - 9 • e, E, +, - and period 	<ul style="list-style-type: none"> • do not use blanks, tabs, carriage returns, non-printable characters • maximum precision is 6 places to the right of the decimal point • if present, a sign (+ or -) for the number must be first (+ is the default) • if present, a sign for the exponent must immediately follow the e or E

① Required fields for the Table View

② Required fields for the Form View

③ These fields appear only when the data type is 4BCD, signed integer, unsigned integer, IEEE Float.

Using the Electronic Data Sheet

The Electronic Data Sheet (EDS) contains operating parameters for the PanelView terminals communicating with other DeviceNet devices on an Explicit messaging level (no scanner).

The EDS parameters can automatically be uploaded to the PanelBuilder tag editor. When the Explicit-Client message type is selected in the tag editor, the “Load From EDS” option appears on the dialog.

To load parameter data from the EDS:

1. Click the Load From EDS button to open the Open dialog.

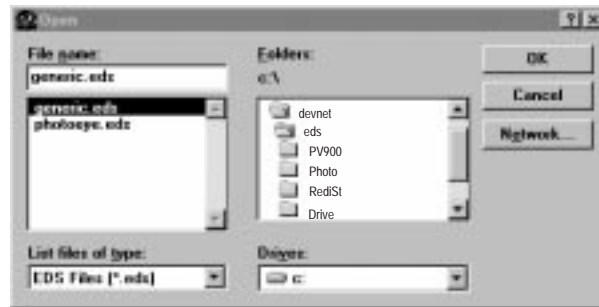

2. Select the EDS file you want to read.
3. After the file is loaded, the following dialog is displayed.



When you select a group, parameters available in that group will be selectable. By default, all parameters are displayed.

4. Select the appropriate parameter. If the parameter has bit-field enumeration associated with it, an Enumerated Data Item should be selected.
5. Select OK to continue.

The class, instance, and attribute associated with the selected parameter is displayed on the tag form.

Downloading Applications over a Serial Link

To download a DeviceNet application from your computer to the PanelView 900 terminal over an RS-232 link:

- connect computer to RS-232 port of PanelView terminal
- download application from the PanelBuilder Application menu

Use PanelBuilder's internal DF1 driver or the DF1 INTERCHANGE driver for the download. The internal DF1 driver uses fixed DF1 settings that match those of the RS-232 port of the terminal.

Downloading Application using the Internal DF1 Driver

① Open the application you want to download.

② Choose Download from the Application menu.

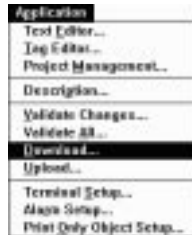

③ Select the Download parameters.

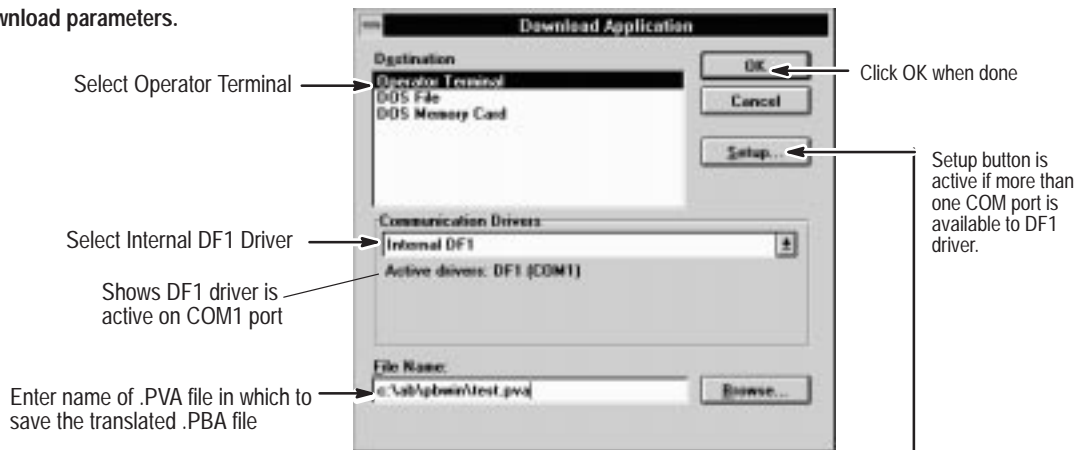

④ Application is validated and translated to a .PVA file.

If errors or warnings are detected, the Exceptions dialog opens. You must correct errors before download can proceed.

⑤ PanelBuilder Software and terminal display status of download.

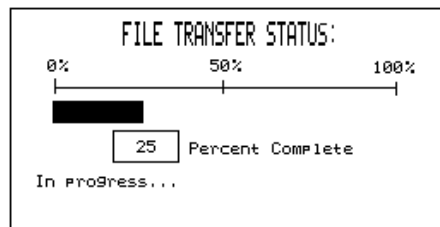
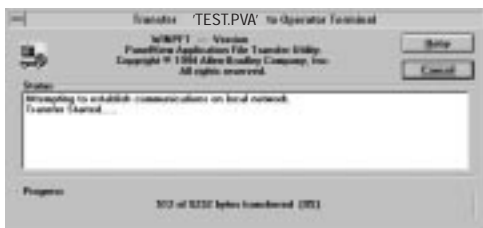

⑥ Terminal resets, verifies and starts application.

DeviceNet Application Report

The application printout for DeviceNet provides the following information:

- configuration data
- tag data
- supplemental data

Error Messages and Codes

The following tables lists error messages and codes specific to DeviceNet communications. For all other messages, refer to the PanelView and PanelBuilder user manuals.

PanelBuilder Tag Error Messages

Message	Recommended Action
Tag: <Tag Name> - Incomplete Address	Change the tag address so it is the following format: I:<word>/<bit> or O:<word>/<bit> where <bit> is required for Bit and Bit Array.
Tag: <Tag Name> - Invalid Element Number	The Tag Address should have a numeric word offset.
Tag: <Tag Name> - Expected Slash / in Tag Address	Add a slash and bit number to the Tag Address
Tag: <Tag Name> - Invalid Bit Number. Bit number must be 0-15.	Change the bit number to a value between 0 and 15.
Tag: <Tag Name> - Expected Output Tag. Tag Address should begin with O.	Change the Tag Address so it begins with an O.
Tag: <Tag Name> - Expected Input Tag. Tag Address should begin with I.	Change the Tag Address so it begins with an I.
Tag: <Tag Name> - Input Element Extends Beyond Input Size.	The word offset in the Tag Address must be less than the Input Size specified on the Communications Setup Dialog.
Tag: <Tag Name> - Output Element Extends Beyond Output Size.	The word offset in the Tag Address must be less than the Output Size specified on the Communications Setup Dialog.
Tag: <Tag Name> - Expected Discrete Tag.	The Data Type implies that the Tag Address should specify a bit number.
Tag: <Tag Name> - Expected Analog Tag.	The Data Type implies that the Tag Address should not specify a bit number.
Tag: <Tag Name> - Invalid Packet Length. Packet Length must be 1-128 bytes.	Change packet bytes to 1-128 bytes.
Tag: <Tag Name> - Cannot be converted to current protocol format.	This tag must be manually edited to the DeviceNet protocol.
Tag: <Tag Name> - Invalid Node Address. Node must be 0-63.	DeviceNet node addresses must be 0-63.
Tag: <Tag Name> - Invalid Bit Offset. Bit Offset must not extend beyond the packet length.	Reduce the Bit Offset.
Tag: <Tag Name> - Expected Read Tag.	Uncheck the Write Tag box on the Tag Form.
Tag: <Tag Name> - Expected Write Tag.	Check the Write Tag box on the Tag Form.
Tag: <Tag Name> - Invalid Address Type. Address must begin with I or O.	Modify the Tag Address to begin with I or O.
Tag: <Tag Name> - Explicit Server Input and Output Tags have been assigned to the same Assembly Instance.	An Assembly Instance can only be assigned all input tags or output tags. Place input and output tags in separate assembly instances.
Tag: <Tag Name> - Invalid Data Size. Data element extends beyond input or output size.	Increase the input or output size on the terminal setup screen.
Tag: <Tag Name> - Expected Colon. I or O should be followed by :	Add a colon : after the I or O.
Tag: <Tag Name> - Bit Offset must be a multiple of 8 for Character Arrays.	Adjust the Bit Offset on the Tag Form.
Tag: <Tag Name> - Explicit Server Input Elements must be 0-63.	Reduce the word offset for the associated Tag Address.

Table continued on the next page.

Message	Recommended Action
Tag: <Tag Name> - Explicit Server Output Elements must be 0-63.	Reduce the word offset for the associated Tag Address.
Tag: <Tag Name> - Data Type implies Packet Bytes should be equal to 2. Certain PanelBuilder controls, however, may require additional bytes. If less than 2 bytes are required, use Bit Array.	Most PanelBuilder controls write only 1 element of data. If the associated Data Type is an Unsigned Integer, this implies 2 bytes will be written by the Tag. However, if tags are assigned to the Block Write of a Piloted Control List, the number of bytes written will be a multiple of the states displayed on the list.
Tag: <Tag Name> - Data Type implies Packet Bytes should be equal to 4. Certain PanelBuilder controls, however, may require additional bytes.	Most PanelBuilder controls write only 1 element of data. If the associated Data Type is a Floating Point, this implies 4 bytes will be written by the Tag. However, if tags are assigned to the Block Write of a Piloted Control List, the number of bytes written will be a multiple of the states displayed on the list.
Tag: <Tag Name> - Data Type implies Packet Bytes should be less than or equal to 2. Certain PanelBuilder controls, however, may require additional bytes.	Most PanelBuilder controls write only 1 element of data. If the associated Data Type is an Bit Array, this implies at most 2 bytes will be written by the Tag. However, if tags are assigned to the Block Write of a Piloted Control List, the number of bytes written will be a multiple of the states displayed on the list.
Tag: <Tag Name> - The length of the data extends beyond the size of the packet.	If the associated tag is an I/O tag, increase either the Input or Output Size. If the associated tag is Explicit-Server, the data size extends beyond the 64 word limit of the Assembly Instance.
Tag: <Tag Name> - The length of the data extends beyond the size of the packet. Adjust Packet Bytes to at least #.	Increase the Packet Bytes assigned to the tag.
Tag: <Tag Name> - This tag cannot be assumed consistent or "atomic". The tag's Message Type is inconsistent with previous tags in this group.	Tags have been assigned to a PanelBuilder control that must be updated in the same data packet. Change the Message Type so that it is the same as other members of this group.
Tag: <Tag Name> - This tag cannot be assumed consistent or "atomic". The Assembly Instance is inconsistent with the previous tags in this group.	Tags have been assigned to a PanelBuilder control that must be updated in the same data packet. Change the Assembly Instance so that it is the same as the other members of this group.
Tag: <Tag Name> - This tag cannot be assumed consistent or "atomic". The Peer's Class, Instance, Attribute, or Node Address is inconsistent with previous tags in this group.	Tags have been assigned to a PanelBuilder control that must be updated in the same data packet. Change the Explicit-Client message so that it references the same peer attribute as other tags assigned to this group.

PanelBuilder Device Error Messages

Message	Recommended Action
Device: <Device Name> - Cannot be converted to current protocol format.	Create a new device entry under the Terminal Setup Dialog.
Device: <Device Name> - Converted to DeviceNet. Default communication parameters will be used.	Update the Communications Setup Dialog to the appropriate network values. (i.e. Node Address, Baud Rate, etc.)
Device: <Device Name> - Communication settings have never been initialized.	Update the Communications Setup Dialog to the appropriate network values. (i.e. Node Address, Baud Rate, etc.)

PanelBuilder Translation Error Messages

Message	Recommended Action
Too many peer accesses. Only 128 Explicit-Client message channels are allowed per application.	Reduce the number of Explicit-Client Tags in your application.
Translation Failure	Contact Allen-Bradley for technical support.

Electronic Data Sheet (EDS) File Error Messages

Message	Recommended Action
The DeviceNet Data Type (#) is unsupported by PanelView. Use of this parameter may produce unexpected results.	There is no corresponding PV Data Type for the DeviceNet parameter that was chosen. Use of this parameter requires knowledge of how the DeviceNet data is structured. For instance, one element of the DeviceNet Time Data Type may be displayed, but the location of the internal fields must be known.
The DeviceNet Data Type (#) does not match the PanelView Data Type chosen. It is recommended that either Bool or Bit Array is chosen.	Bool or Bit Array corresponds most closely to the parameter chosen.
The DeviceNet Data Type (#) does not match the PanelView Data Type chosen. It is recommended that either Signed or Unsigned Integer is chosen. Display value scaling may be necessary.	Signed or Unsigned Integer corresponds most closely to the parameter chosen.
The DeviceNet Data Type (#) does not match the PanelView Data Type chosen. It is recommended that Floating Point is chosen.	Floating Point corresponds most closely to the parameter chosen.
The DeviceNet Data Type (#) does not match the PanelView Data Type chosen. It is recommended that Char Array is chosen.	Character Array corresponds most closely to the parameter chosen.
This parameter designates that extended precision scaling should be used to display the parameter. PanelView does not support extended precision scaling.	The chosen parameter specifies Extended Precision Scaling. The appropriate scaling factor must be manually determined and entered into the Scale and Offset fields on the Tag Form.
In order to support scaling, the PV Data Type will be changed to Unsigned Integer.	The chosen parameter has scaling factors. To support scaling factors, an appropriate PV Data Type must be chosen. The scaling factor will be calculated and entered as the Scale and Offset values on the Tag Form.
Unable to open EDS File.	The system was unable to open the specified EDS file.
Invalid EDS File.	The EDS file is corrupt or contains too many parameters to be read.
Could not allocate memory.	The system is unable to allocate enough memory to read the EDS file.

Communication Status Error Messages

These errors appear as a banner at the top of an application screen (error #634 in upper left corner) or as Mod/Net LED status display on the terminal configuration screen.

Errors numbered less than 10 are considered minor fault conditions and will clear automatically when corrected. Errors numbered above 10 require that the terminal be reset to clear the error.

Code	Indicates	Recommended Action(s)
1	No connections established. Occurs on power-up until a device connection is established on the network.	Establish a connection over DeviceNet to the PanelView.
2	A connection is in the timed out state. Occurs once I/O messaging is stopped after an I/O connection has been running.	Make sure that wiring is OK on the network and that the master device (scanner, etc.) is operational.
3	An Explicit-Client tag cannot be obtained. Occurs if the device associated with an Explicit-Client tag is not responding or the peer tag does not exist at the specified class, instance, and attribute number.	Make sure that the specified location of the data is correct and that the end device is attached and operational. For write tags, ensure that the appropriate attribute is targeted. If the targeted device is UCMM capable, ensure it has enough available explicit message connections to allow the PanelView to take one. If the targeted device is not UCMM capable, ensure that it is owned by a Master device (scanner, etc.).
4	A zero length I/O message was received placing the I/O application in idle mode. Occurs when the scanner is in program mode.	Error clears when switched back to run. Correct the problem of the Master sending the I/O idle condition.
5	Message Overrun. Message traffic from the PanelView is being generated quicker than it is possible to send the data. Occurs with large I/O sizes when Change-Of-State is being used and state changes are occurring very quickly or if polling too fast when large I/O sizes are involved.	Slow down I/O polling or the state changes generating change of state I/O messages. Use cyclic I/O at a fast heartbeat rate rather than change-of-state. Use the production inhibit capability on the master.
11	No network power detected. Occurs if no network 24V is present.	Make sure DeviceNet wiring is providing power to the PanelView and reset the terminal.
12	Dup MAC Failure. Occurs if the PanelView powers up with the same Node Address present on the network.	Change the node address to one not currently in use and reset the terminal.
13	Bus-Off Interrupt occurred. CAN Chip is held in reset. Caused by noise on network signal lines or attempting to attach to the network at the wrong baud rate. May also occur if some other device on the network attaches at the wrong baud rate	Make sure Baud Rate is correct and wiring is correct on the network, including termination resistors. Reset the terminal.

Alert Messages

These messages appear as a box in the middle of the screen (Error #636 in upper left of box) and alert the user to a particular condition. Operation of the terminal continues. Alert messages can be cleared.

Code	Indicates	Recommended Action(s)
2	Unsupported DeviceNet Message type received. A message was received by the Network Access Object that is not supported.	This should not occur in normal operation. Clear the message and if the problem reoccurs, consult Allen-Bradley.
3	Initial Writes Failure. The Motherboard failed to send all input data to the daughter card prior to network startup. This error should not happen during normal operation.	Clear the message and if the problem reoccurs, consult Allen-Bradley.
4	Invalid Explicit-Client Address. Occurs at run time if the node address associated with an Explicit-Client tag is the same as the PanelView's own.	Clear the message and determine which tag in the application is pointing to the PanelView's node address. Correct the application.
7	Change-Of-State Input Overrun. Occurs if PanelView state changes on I/O input data occurred faster than the PanelView could send them to the I/O scanner.	Clear the message. Excessive network traffic could cause this problem if inputs are changing rapidly.
8	Identity Object Reset Service received over DeviceNet. Occurs if an external device sends a Identity Object Reset Service to the PanelView.	An external network device has requested the PanelView be reset. Reset the PanelView manually from the configuration screen.
10	Unsupported DeviceNet message received. Should not occur under normal operating conditions.	Clear the message and if the problem reoccurs, consult Allen-Bradley.
12	Invalid ASA Number (0x00000000 or 0xFFFFFFFF). Will not occur unless the flash memory has been corrupted or an invalid ASA number was programmed in the production process.	Clear the message. The message will reoccur each time the terminal is reset. The terminal will operate normally but the problem should be corrected. Consult Allen-Bradley.
13	Invalid Screen Context Priority received. Should not occur under normal operating conditions.	Clear the message and if the problem reoccurs, consult Allen-Bradley.
14	Get Next Scan Item Failed in peer mode. Should not occur under normal operating conditions.	Clear the message and if the problem reoccurs, consult Allen-Bradley.
15	Explicit-Client Input Data not received. Will occur if an input (push-button, etc.) changes a second time before its previous state was successfully sent on the network. Only for Explicit-Client Tags.	Clear the message. Excessive network traffic could cause this problem if inputs are changing rapidly. Handle high speed input data over I/O connections if possible. Also make sure that the addressed attribute exists and is settable on the network.
16	I/O Connection Size does not match size of I/O data in Assembly Instances 1 & 2. Programmed connection sizes for I/O do not match the amount of data represented by the I/O type tags.	Clear the message and if the problem reoccurs, consult Allen-Bradley.
19	Get Next Context Request Failure. In Explicit-Client mode scanning, the request for obtaining the next tag in current context failed. Should not occur under normal operating conditions.	Clear the message and if the problem reoccurs, consult Allen-Bradley.

Fault Messages

These messages indicate critical fault conditions. They appear as a full screen box with an Error #635 in the upper left corner. The terminal must be reset to clear the condition. If the problem persists, Allen-Bradley should be contacted and the two digit code number associated with the error noted.

Code	Indicates	Recommended Action(s)
17	Client Object Failed. No way to force this. Should not occur under normal operating conditions.	Reset the terminal and if the problem reoccurs, consult Allen-Bradley.
18	CAN Chip Failed to initialize. Should not occur under normal operating conditions.	Reset the terminal and if the problem reoccurs, consult Allen-Bradley.
37	The channel size of a particular channel exceeds the size limitations set by the daughtercard. Should not occur under normal operating conditions.	Reset the terminal and if the problem reoccurs, consult Allen-Bradley.
20xx	Critical Internal DeviceNet Firmware fault. Should not occur under normal operating conditions.	Reset the terminal and if the problem reoccurs, consult Allen-Bradley.
Errors 9, 10, 11, 21, 22, 24, 25, 26, 27, 28, 29, 30, 31, 32, 34, 35, and 36	Internal faults associated with motherboard/daughtercard communications. Should not occur under normal operating conditions.	Reset the terminal and if the problem reoccurs, consult Allen-Bradley.

AdaptaScan Application

This application provides an example of using explicit-client messages to monitor decoded bar code data and change attributes of an AdaptaScan Bar Code Reader. The AdaptaScan is connected directly to the PanelView.

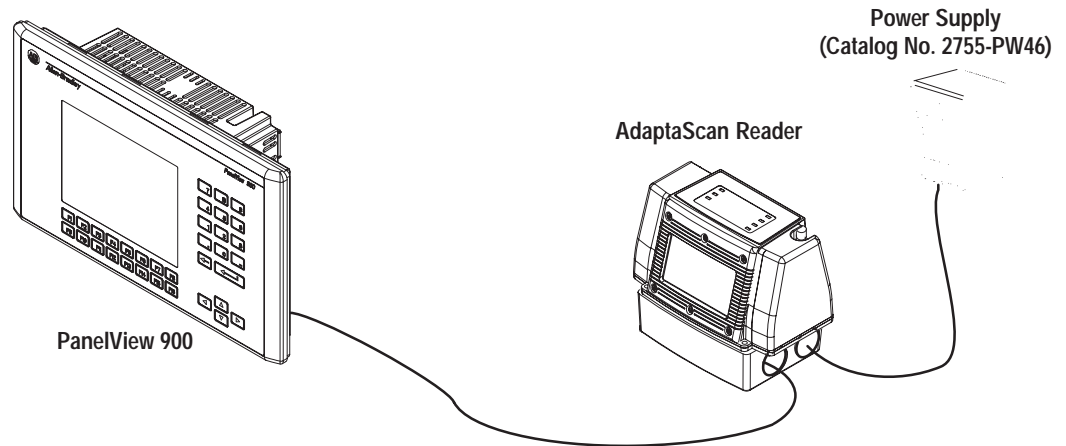

The DeviceNet network must be supplied with power. In this application, you can use the AdaptaScan power supply (Catalog No. 2755-PW46). The power supplies used with DeviceNet are sized to the number of devices and DeviceNet cable lengths. Review your DeviceNet literature for DeviceNet network configuration data.

Note: AdaptaScan software version 7.0 or later with reader firmware 7.0 or later is required to run this application.

Connections

The PanelView connects directly to the DeviceNet terminal block in the AdaptaScan wiring base. Refer to Publication No. 2755-837 for DeviceNet and power supply connections.

PanelView Screen

The following shows how the PanelView screen appears in PanelBuilder (Catalog No. 2711-ND3). You will need to create this screen for your application.



In this application, the PanelView terminal:

- displays decoded bar code data from the AdaptaScan Reader
- displays the package count of the AdaptaScan Reader
- resets the package count

Read Bar Code Data Tag Configuration

The dialog box for the bar code display object is shown below. The display is configured as an ASCII string with an embedded variable (bar code data). The Field Width is set to 24 characters and is based on the expected maximum bar code data length in characters. The tag name is Bar_Code_Data.



By selecting the Edit Tag option, you can edit the tag data as shown below.

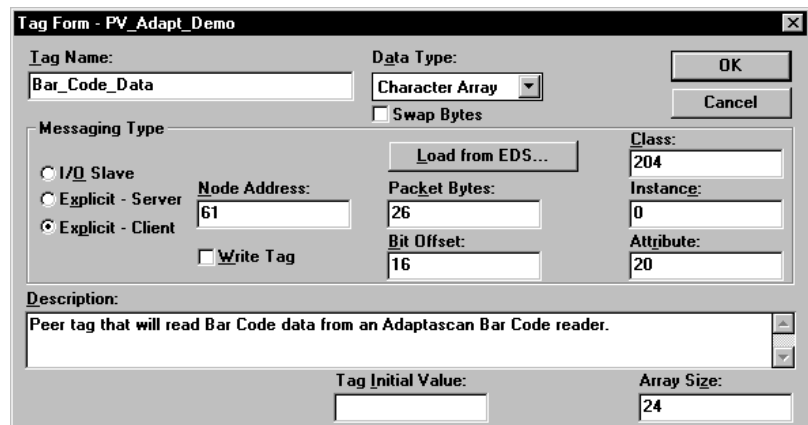

The tag data type is “Character Array”. It is an explicit-client read message with the Class, Instance and Attribute values as shown. To read bar code data, the bit offset must be set to 16. The offset is necessary since the first two bytes represent the length of the requested data.

Read Package Counter Tag Configuration

AdaptaScan can keep a count of how many times it was triggered or asked to read a bar code. The dialog box for the package count numeric display object is shown below.



The PanelView will display six digits of the Package count value, the package count from the AdaptaScan can be up to ten digits. By selecting the Edit Tag option, you can edit the tag data as shown below.

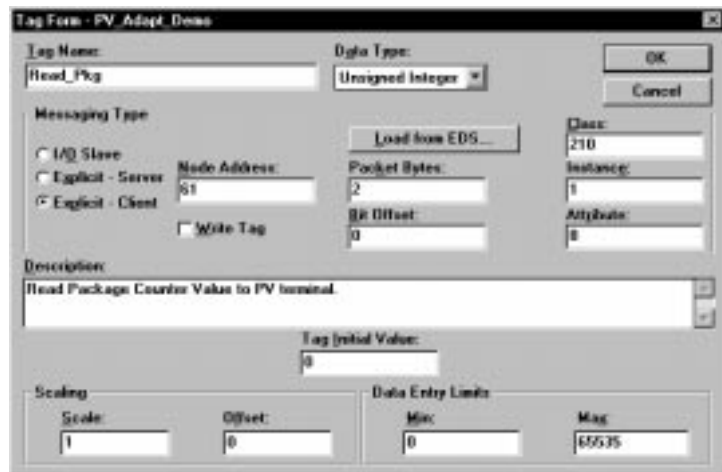

The data type is Unsigned Integer. The data type should be changed to Signed Integer. The Class, Instance and Attribute are set to read the AdaptaScan package count.

Note: Use the Print function of the AdaptaScan software to print application data. The report will provide you with the DeviceNet Class and Instance values for the configuration data.

Write Package Count Reset

The PanelView uses an explicit-client message to reset the AdaptaScan package count. The reset message is sent by a push button object in PanelView.

The dialog box for the package count reset push button is shown below.

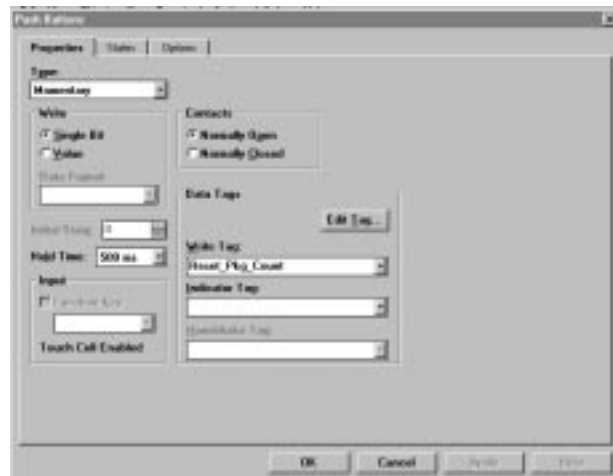

By selecting the Edit Tag option, you can edit the tag data as shown below.

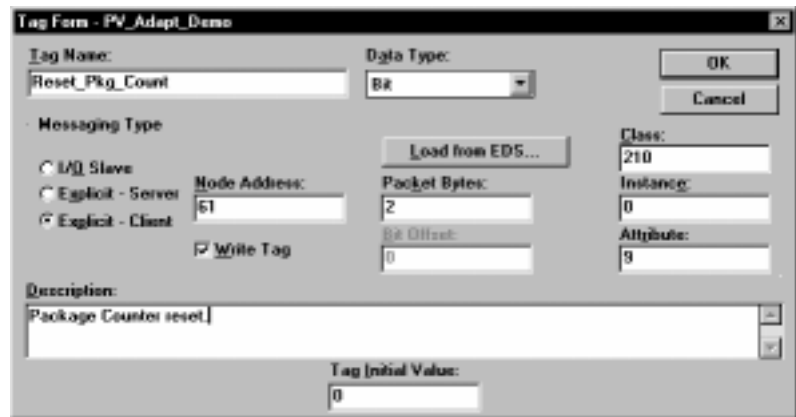

Note: The Write Tag box is checked indicating a write tag.

Note: Use the Print function of the AdaptaScan software to print application data. The report will provide you with the DeviceNet Class and Instance values for the configuration data.

AdaptaScan Configuration

The AdaptaScan Reader must be configured to make data available for the PanelView terminal. You must configure the AdaptaScan Reader for the bar code symbology being read, the number of bar codes, scan pattern and triggering as you would for any other application. Refer to Publication No. 2755-838 for information regarding the basic set up of the AdaptaScan Bar Code Reader. The following sections only provide the information necessary to make the data available for the PanelView terminal.

Making Bar Code Data Available

To make the bar code data available on DeviceNet, the AdaptaScan Bar Code Reader must be configured to make the data available. The two dialog screens shown below set up a message field that contains the bar code data. See Publication No. 2755-838. The fields containing Symbol 1, Symbol 2, Symbol 3, define three bar code types configured for the AdaptaScan Reader.



Making Package Counter Data Available

Package counter data must be made available to the PanelView terminal by setting up an unconditional match in the AdaptaScan Bar Code Reader. The figure below shows the two dialog boxes that need to be modified.

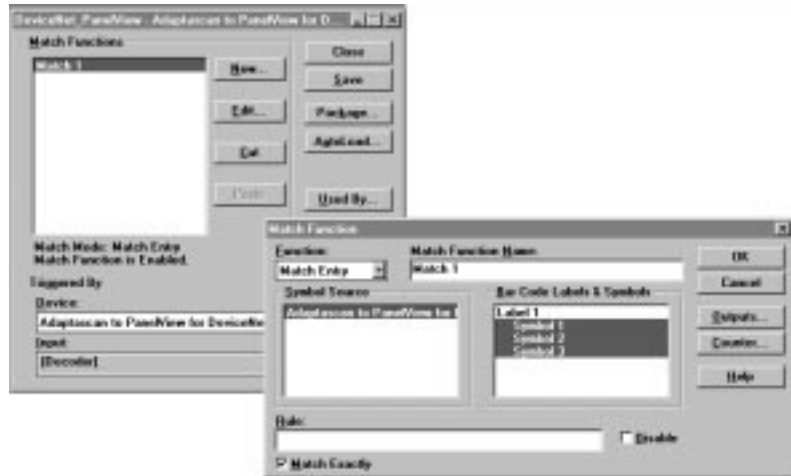



Rockwell Automation helps its customers receive a superior return on their investment by bringing together leading brands in industrial automation, creating a broad spectrum of easy-to-integrate products. These are supported by local technical resources available worldwide, a global network of system solutions providers, and the advanced technology resources of Rockwell.

Worldwide representation.



Argentina • Australia • Austria • Bahrain • Belgium • Bolivia • Brazil • Bulgaria • Canada • Chile • China, People's Republic of • Colombia • Costa Rica • Croatia • Cyprus • Czech Republic • Denmark • Dominican Republic • Ecuador • Egypt • El Salvador • Finland • France • Germany • Ghana • Greece • Guatemala • Honduras • Hong Kong • Hungary • Iceland • India • Indonesia • Iran • Ireland • Israel • Italy • Jamaica • Japan • Jordan • Korea • Kuwait • Lebanon • Macau • Malaysia • Malta • Mexico • Morocco • The Netherlands • New Zealand • Nigeria • Norway • Oman • Pakistan • Panama • Peru • Philippines • Poland • Portugal • Puerto Rico • Qatar • Romania • Russia • Saudi Arabia • Singapore • Slovakia • Slovenia • South Africa, Republic of • Spain • Sweden • Switzerland • Taiwan • Thailand • Trinidad • Tunisia • Turkey • United Arab Emirates • United Kingdom • United States • Uruguay • Venezuela

Rockwell Automation Headquarters, 1201 South Second Street, Milwaukee, WI 53204-2496 USA, Tel: (1) 414 382-2000 Fax: (1) 414 382-4444

Rockwell Automation European Headquarters, Avenue Hermann Debroux, 46, 1160 Brussels, Belgium, Tel: (32) 2 663 06 00, Fax: (32) 2 663 06 40

Rockwell Automation Asia Pacific Headquarters, 27/F Citicorp Centre, 18 Whitfield Road, Causeway Bay, Hong Kong, Tel: (852) 2887 4788, Fax: (852) 2508 1846

World Wide Web: <http://www.ab.com>