



Allen-Bradley

***Hand-Held
Decoded Bar
Code Scanners***

(Cat. No. 2755-HDG-4)

User Manual



Important User Information

The illustrations, charts, sample programs and layout examples shown in this guide are intended solely for purposes of example. Since there are many variables and requirements associated with any particular installation, Allen-Bradley does not assume responsibility or liability (to include intellectual property liability) for actual use based upon the examples shown in this publication.

Allen-Bradley publication SGI-1.1, *Safety Guidelines for the Application, Installation, and Maintenance of Solid-State Control* (available from your local Allen-Bradley office), describes some important differences between solid-state equipment and electromechanical devices that should be taken into consideration when applying products such as those described in this publication.

Reproduction of the contents of this copyrighted publication, in whole or in part, without written permission of Allen-Bradley Company, Inc., is prohibited.

Throughout this manual we use notes to make you aware of safety considerations:



ATTENTION: Identifies information about practices or circumstances that can lead to personal injury or death, property damage or economic loss.

Attention statements help you to:

- identify a hazard
- avoid the hazard
- recognize the consequences

Important: Identifies information that is critical for successful application and understanding of the product.

Table of Contents

Preface

Intended Audience	P-1
Contents of this Manual	P-2
Related Publications	P-3
Laser Warning Symbol	P-3

Chapter 1 Scanner Features

Scanner Features	1-2
LED Indicators	1-3
Configuration Options	1-4
Decoding	1-4
Safety Labels	1-5
Scanning Ranges	1-6
Accessories	1-8

Chapter 2 Connecting and Operating Scanner

Overview	2-2
Scanner to Synapse Cable or AdaptaScan Pass Through Cable ..	2-3
Scanner Cable to Synapse Cable Connection	2-4
Scanner Emulation Synapse Cable Connections	2-5
RS-232 Synapse Cable Connection	2-6
Keyboard Wedge Synapse Cable Connections	2-8
AdaptaScan Pass Through Cable Connection	2-10
Connecting Scanner to Enhanced Decoder Scanner Port	2-12
Connecting Scanner to Enhanced Decoder Aux Port	2-13
Connecting Scanner to Flexible Interface (RB) Module	2-14
Connecting Scanner to a PLC	2-15
Connecting Scanner to an SLC	2-16
Operating the Scanner	2-17
Automatic Shutoff	2-18
Audible Response	2-18
Configuring the Scanner and Synapse Cables	2-20

Chapter 3 Configuring the Scanner

Important Notes on Configuring a Scanner	3-1
Scanner Configuration Bar Codes	3-1
Configuring the Scanner	3-2
Scanner Default Settings	3-2
Select Cable Type	3-4
Select Symbologies	3-4
UPC / EAN Options	3-5
Codabar Options	3-8
Code 39 Options	3-9
MSI Plessey Options	3-11
I 2-of-5 and Discrete 2-of-5 Options	3-12
Data Format Options	3-13
Laser Control and Audible Response Options	3-17

Chapter 4 Communication Setup (Cable Configuration)

Cable Defaults	4-1
Setting RS-232 Synapse Cable Options	4-2
Setting IBM PC Keyboard Wedge Synapse Cable Options	4-9
Setting DEC VT520 Wedge Synapse Cable Options	4-13
Setting DEC VT220 / VT320 / VT420 Wedge Synapse Cable Options	4-16
Setting Scanner Emulation Synapse Cable Options	4-19
Setting AdaptaScan Pass Through Cable Options	4-24

Chapter 5 Troubleshooting and Maintenance

Troubleshooting the Scanner	5-2
Cleaning the Scan Window	5-4

Appendix A Specifications

Appendix B Hands-Free Stand Operation

Appendix C Scanner Pinout Connections

Appendix D ASCII Chart

Appendix E European Union Directive Compliance

Glossary

Using this Manual

Read this preface to familiarize yourself with the rest of the manual. This preface covers the following topics:

- intended audience
- chapter contents
- laser warning symbol
- related publications

Intended Audience

No special knowledge is required to understand this document or use the scanner. Decoded scanners may be connected to a variety of host devices. We assume you are familiar with the host's communication ports.

Important: You will need the Bar Code Programming Guide for Decoded Hand-Held Scanners (Publication 2755-6.5) to configure the scanner and interface cables.

Contents of this Manual

The following table briefly describes the contents of each section.

Chapter	Title	Contents
Preface	Using this Manual	Describes the purpose, background, and scope of this manual. Also provides a list of related publications.
1	Scanner Features	Overview of the scanner. Includes read range charts and description of accessory items.
2	Connecting and Operating the Scanner	Describes how to connect the scanner to a host device. Operating tips are also provided.
3	Configuring the Scanner	Describes how to configure the scanner using the bar codes provided in the Bar Code Programming Guide.
4	Communication Setup (Cable Configuration)	Describes how to configure the scanner cables using the bar codes provided in the Bar Code Programming Guide.
Appendix A	Specifications	Provides physical, electrical and environmental specifications.
Appendix B	Hands-Free Stand Operation	Describes scanner automatic operation when using the adjustable stands.
Appendix C	Scanner Connector Pinouts	Provides scanner pinout signal names and a brief description of each.
Appendix D	ASCII Chart	ASCII conversion chart also provides Code 39 Full ASCII encoded characters.
Appendix E	European Union Directive Compliance	Provides requirements for scanners when used within the European Union.
	Glossary	Provides definitions of commonly used terminology.
Inside Back Cover	Bar Code Test Symbols	Sample symbols useful for testing the operation of your bar code system.

Related Publications

Below is a list of related publications you may need to refer to when using the scanner.

Publication No.	Title
2755-6.5	Bar Code Programming Guide Provides the configuration bar codes for the decoded scanner and interface cables.
2755-921	Bar Code Basics Describes bar code symbologies, equipment, and typical applications.

Laser Warning Symbol

Be aware of the following laser caution symbol.



CAUTION

LASER LIGHT - DO NOT STARE INTO BEAM.
1.0 mW MAXIMUM POWER CLASS II LASER
LASER DIODE-680nm WAVELENGTH PRODUCT



Scanner Features

This chapter describes the features of the decoded scanner. Included are descriptions of:

- major features
- LEDs
- scanning ranges
- configuration options
- decoding
- safety labels
- accessories

Scanner Features

The scanners use a low power visible (red) laser diode for scanning. The trigger turns on the laser which scans a label at approximately 36 scans per second.

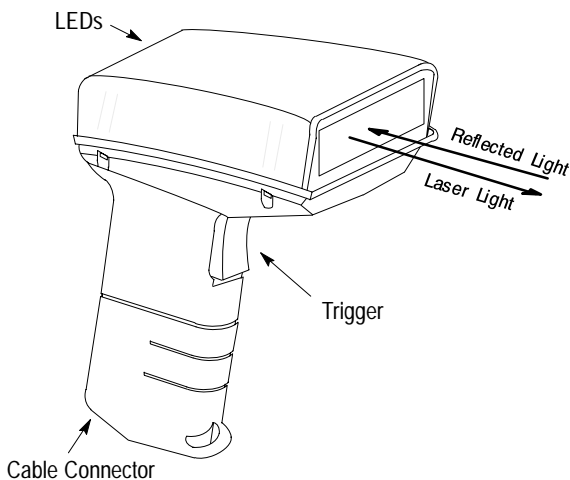

The laser beam:

- exits through the scan window
- reflects off the label back through the window
- is detected by a sensor in the scanner

When a label is read, the laser beam is automatically turned off until the trigger is pressed again. If no label is read, the laser beam automatically turns off after 0.5 to 3 seconds (timeout is adjustable) and remains off until the trigger is released and pressed again.

Note: When used with the adjustable stands (Catalog No. 2755-HFN-K1, -K2), the scanner operates automatically for hands-free operation. Refer to Appendix B.

LED Indicators

On the back of the scanner there is a clear window through which two LEDs are visible.

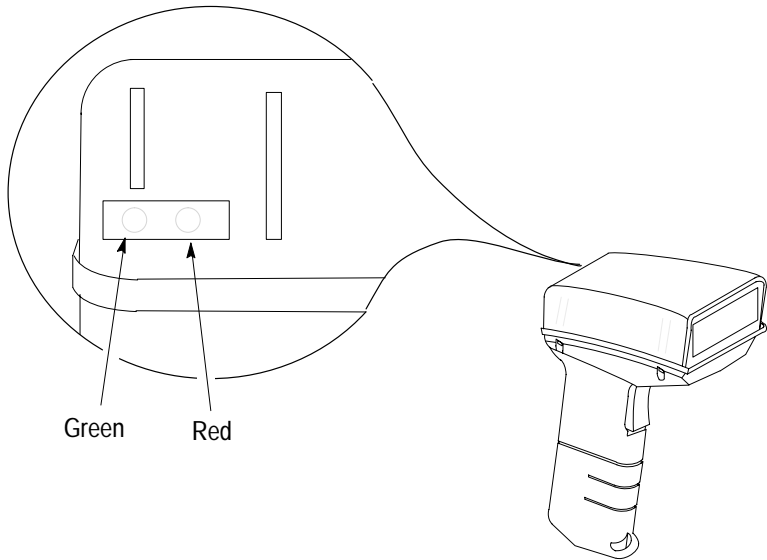

Green LED = Decode, indicating that a bar code symbol has been scanned and decoded. LED remains on until the next scan (trigger pressed).

Red LED = Scanning, indicating that the laser light is on.

Configuration Options

The scanner is readily adaptable to a wide variety of applications by scanning configuration bar codes. The configuration bar codes control the operation of:

- decoding
- laser light
- communications

Chapters 3 and 4 describe the configuration options.

Decoding

The scanner can decode the following symbologies:

- UPC-A
- EAN 8
- Codabar
- Code 39 Full ASCII
- Interleaved 2 of 5
- MSI Plessey
- EAN 128
- UPC-E
- EAN 13
- Code 39
- Discrete 2 of 5
- Code 128
- Code 93

The scanner is autodiscriminating so that multiple symbologies may be enabled at the same time. The only exception is the scanner cannot discriminate between Code 39 and Code 39 Full ASCII.

Safety Labels

The scanners use a low power visible laser diode. As with any bright light source, you should avoid staring directly into the beam. Momentary exposure to a CDRH Class II laser is not known to be harmful.

The following figure shows the location of all safety labels as they appear on the scanner.

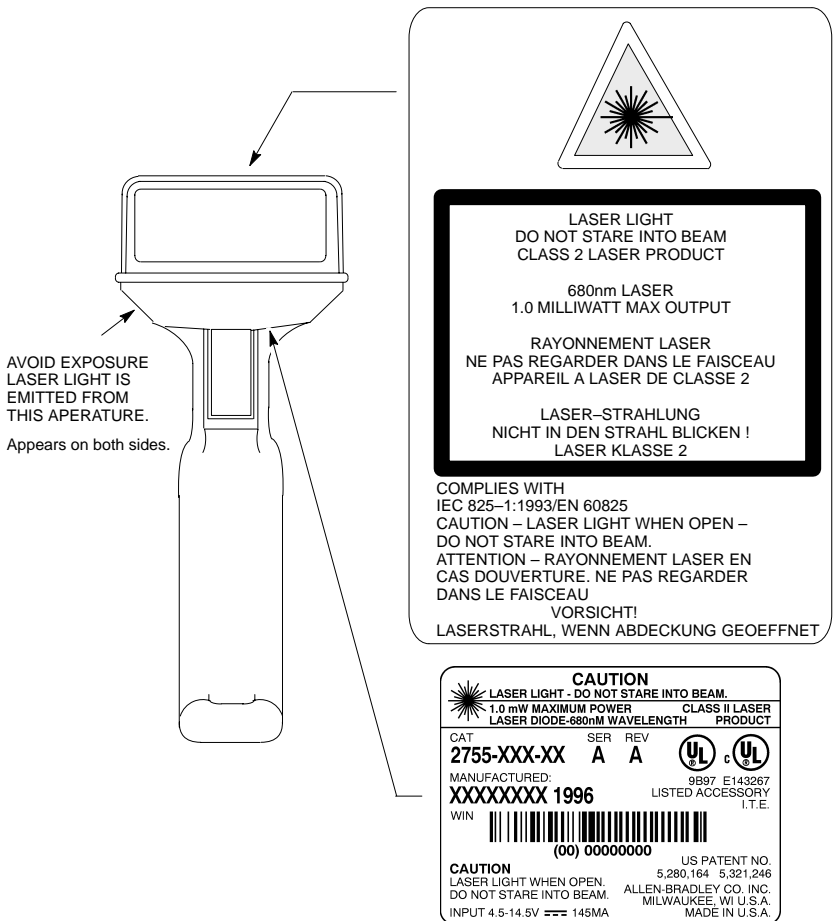

Scanning Ranges

The scanner can read bar code symbols at various distances depending upon the bar code width (width of bars or spaces).

Minimum Bar Code Width	Read Range (Catalog No. 2755-HDG4) Inches / Centimeters
4.0 mil (.13 mm)	1.5 in to 2.0 in (3.8 cm to 5.1 cm)
5.0 mil (.13 mm)	1.25 in to 3.25 in (3.2 cm to 8.2 cm)
7.5 mil (.19 mm)	0.0 in to 7.0 in (0.0 cm to 17.8 cm)
20.0 mil (.51 mm)	0.0 in to 25.0 in (0.0 cm to 63.5 cm)
40.0 mil (1.02 mm)	2.0 in to 40.0 in (5.1 cm to 101.6 cm)
55.0 mil (1.40 mm)	3.0 in to 55.0 in (7.6 cm to 140 cm)

**Decoded Scanner
Catalog No. 2755-HDG-4**

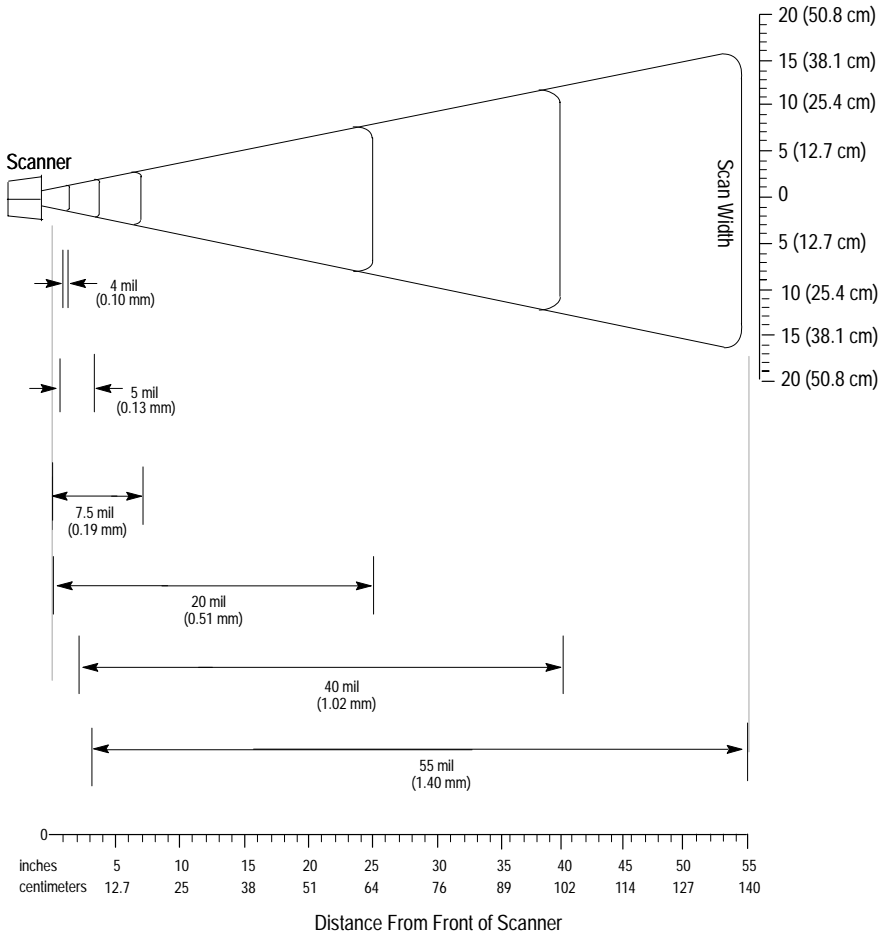

Accessories

The following accessories are available.

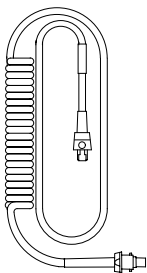

Scanner Cables – Connects scanner to Synapse cable. See page 2–3 for connections.

- 8 ft. / 2.44 meter
(Catalog No. 2755-HDC-GS1-08)
- 20 ft. / 6.1 meter
(Catalog No. 2755-HDC-GS1-20)

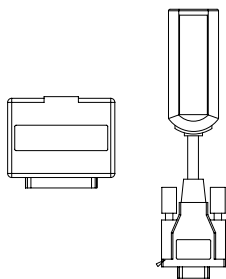

RS-232 Synapse Cables – Provide RS-232 output. Cables are configurable. See page 2-7 for connections.

- RS-232-C, 25-pin DB, male, Txd on Pin 3
(Catalog No. 2755-HFC-SR2-01)
- RS-232-C, 9-pin DB, female, Txd on Pin 2
(Catalog No. 2755-HFC-SR3-01)

Power Supplies – Connect to RS-232, keyboard wedge or scanner emulation Synapse cable. Provides power for the scanner ①.

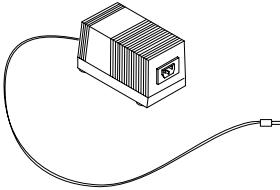

- 100 - 240 VAC, 50 - 60 Hz
(Catalog No. 2755-HFP-D1)
- Power cable for power supply, IEC 320, terminated, US 110V AC
(Part No. 77121-801-01)
- Power cable for power supply, IEC 320, unterminated, US 240V AC
(Part No. 77121-801-02)
- Power cable for power supply, IEC 320, unterminated, European 240V AC
(Part No. 77121-801-03)

① Some applications may not require a power supply when the host provides adequate power for the scanner. This ability of the host to power the scanner will vary with system configurations. The scanner with cable requires 150 mA at 5 volts (typical).

Keyboard Wedge Synapse Cables – Connects between keyboard and host device. Host device receives decoded bar code data the same as keyboard input. See page 2–8 for connections.

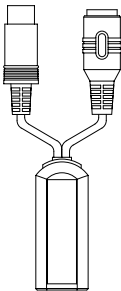

- For IBM XT/AT keyboard, 5-pin DIN
(Catalog No. 2755-HFC-SP1-01)
- For PS/2 keyboard, 6-pin Mini-DIN
(Catalog No. 2755-HFC-SP2-01)
- For DEC VT220, 320, 420 keyboards
(Catalog No. 2755-HFC-SV1-01)
- For DEC VT520 keyboards
(Catalog No. 2755-HFC-SV2-01)

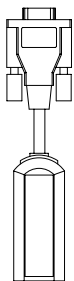

Scanner Emulation Synapse Cable – Provides undecoded scanner output. See page 2-12 for connections.

- (Catalog No. 2755-HFC-SA1-01)

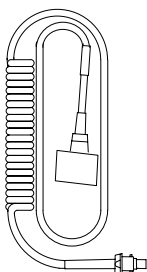

AdaptaScan Pass Through Cable – Connects scanner to custom cable for connection to AdaptaScan RS-232 and power terminal blocks. See page 2-10 for connections.

- RS-232-C, 25-pin DB, male, Txd on Pin 3
(Catalog No. 2755-HDC-GA2-08)

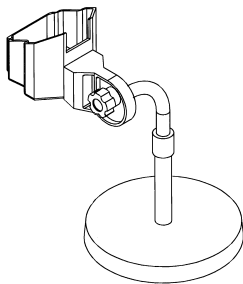

Adjustable Stands – Provide hands-free operation. When placed into the stand, the scanner automatically turns on and remains on in a blinking mode. Any symbol passed under the scan line is decoded. Has separate adjustments for scanner angle and height.

- 5 to 18 inch (127 to 457 mm) height
(Catalog No. 2755-HFN-K1)
- 9 to 16 inch (229 to 406 mm) height
(Catalog No. 2755-HFN-K2)

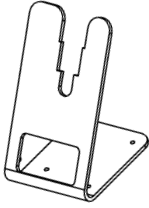

Multi-mount Stand – Rubber coated, fixed mount holder for counter or wall mounting. The stand has the following approximate dimensions: 3.5 x 4.0 x 6.5 inches (89 x 102 x 165 mm).

- (Catalog No. 2755-HFN-K3)

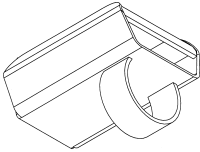

Protective Boot – Heavy canvas boot provides additional protection for the scanner.

- (Catalog No. 2755-HFN-H1)

Connecting and Operating Scanner

This chapter describes how to connect and test the operation of the scanner. Sections include:

- Scanner cable
- Scanner Emulator Synapse cable connections
- RS-232 Synapse cable connections
- Keyboard Wedge Synapse cable connections
- AdaptaScan Pass Through cable connections
- Allen-Bradley Enhanced Decoder applications
- Flexible Interface Module (RB) application
- PLC application
- SLC application

Safety



ATTENTION: Caution - use of controls or adjustments or performance of procedures other than those specified herein may result in hazardous laser light exposure.

Overview

The scanner may be connected to a variety of host devices through an interface cable. The communication parameters for the cables are configured by scanning bar codes. There are four types of cables:

- Scanner Emulator Synapse cable
- RS-232 Synapse cable
- Keyboard Wedge Synapse cable
- AdaptaScan Pass Through cable

Note: The AdaptaScan Pass Through cable (Catalog No. 2755-HDC-GA2-08) provides a physical link between the scanner's output connector and a user supplied custom cable connected to an AdaptaScan Bar Code Reader's RS-232 and power terminal blocks.

All configuration bar codes are in the Bar Code Programming Guide for Decoded Hand-Held Scanners (Publication No. 2755-6.5).

Scanner to Synapse Cable or AdaptaScan Pass Through Cable

The scanner to synapse cable (Catalog No. 2755-HDC-GS1-08, -20) or AdaptaScan Pass Through cable (Catalog No. 2755-HDC-GA2-08) connect to the bottom of the scanner handle.

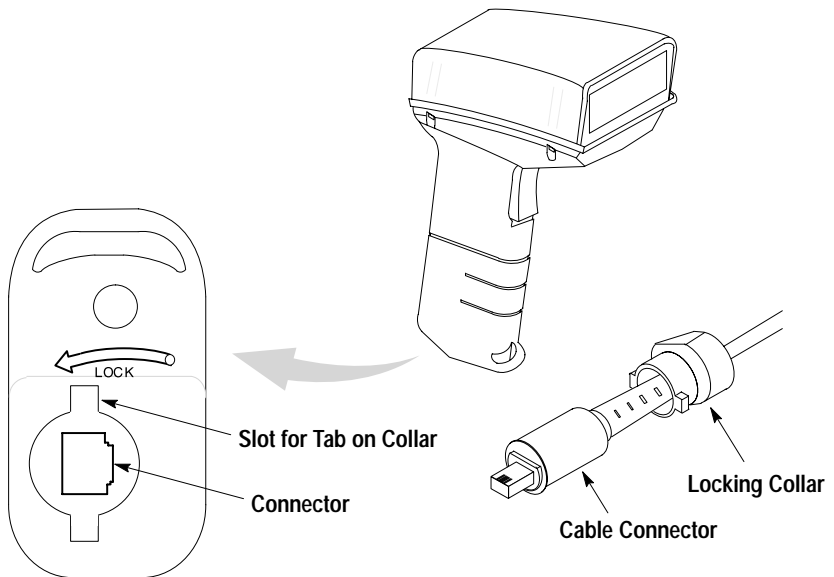

To attach the cable to the scanner.

1. Pull back the locking collar from the connector.
2. Insert the cable connector into the scanner.
3. Align the tabs on the locking collar with the slots on the handle.
4. Push in and turn the locking collar counterclockwise to lock.
Connector is locked when flat edge of locking collar aligns with the flat edge of the scanner handle.

Remove a scanner cable from a scanner by rotating the locking collar clockwise until the cable can be pulled out of the scanner.

Scanner Cable to Synapse Cable Connection

To connect the scanner cable to a Synapse cable, push the cable into the connector until you hear the connector snap in place. To remove the scanner cable, press down on the small raised bump on the connector end and remove cable.

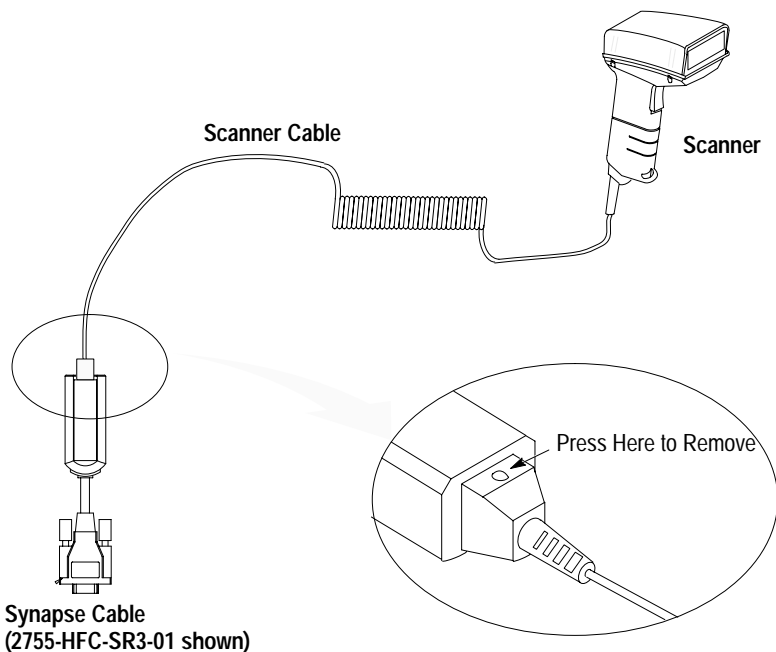

Scanner Emulation Synapse Cable Connections

Use the scanner emulation Synapse cable to provide undecoded output to a scanner input port of a bar code decoder (cable has female 9-pin DB connector). The following scanner emulation cable is available.

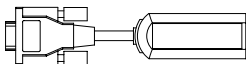

Catalog No. 2755-HFC-SA1-01

A separate power supply provides power to the scanner. The power supply plugs into the scanner emulation Synapse cable.

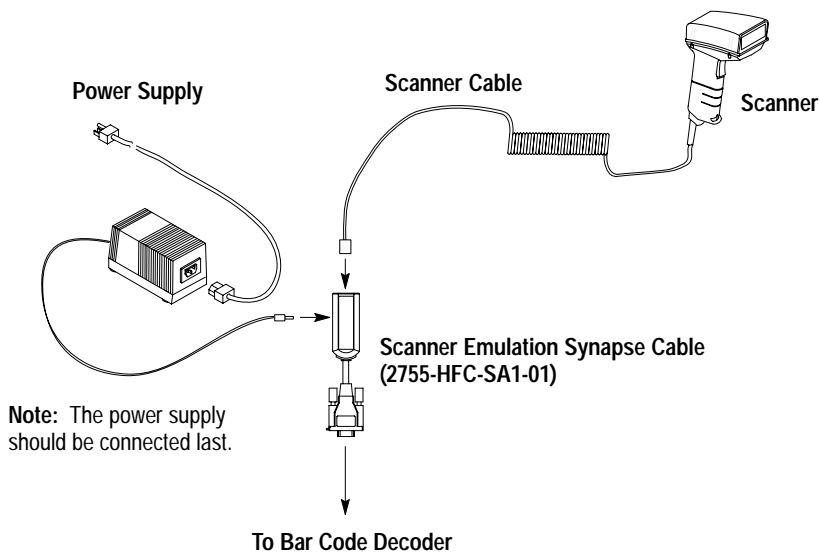

ATTENTION: Do not install the scanner emulation Synapse cable with power applied to either the Synapse cable or decoder. Failure to follow this caution may result in damage to the scanner, Synapse cable, or decoder.

RS-232 Synapse Cable Connections

Use the RS-232 Synapse cable to connect the scanner to any host RS-232C input port. Two types of RS-232 Synapse cables are available:

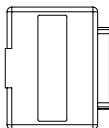

Catalog No. 2755-HFC-SR2-01

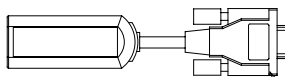

Catalog No. 2755-HFC-SR3-01

RS-232 Synapse Cable	Output Connector	Output Signal
2755-HFC-SR2-01	Male 25-pin DB	RS-232C, Txd on Pin #3
2755-HFC-SR3-01	Female 9-pin DB	RS-232C, Txd on Pin #2



ATTENTION: Do not install the RS-232 Synapse cable with power applied to either the Synapse cable or host device. Failure to follow this caution may result in damage to the scanner, Synapse cable, or host device.

Connect the scanner to an RS-232 port as shown below. A separate power supply provides power to the scanner. The power supply plugs into the RS-232 Synapse cable.

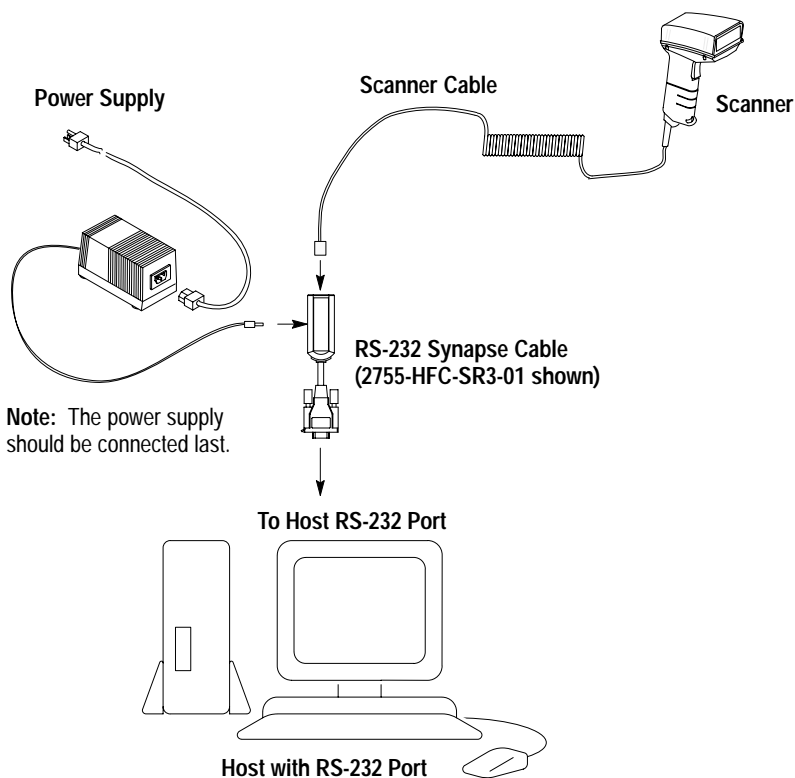

Keyboard Wedge Synapse Cable Connections

Use the keyboard wedge Synapse cable to connect the scanner between a keyboard and a host device. The host device interprets the decoded scanner output the same as keyboard data. Four types of keyboard wedge Synapse cables are available:

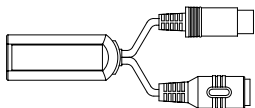

Catalog No. 2755-HFC-SP1-01

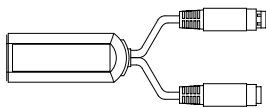

Catalog No. 2755-HFC-SP2-01

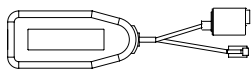

Catalog No. 2755-HFC-SV1-01

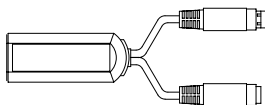

Catalog No. 2755-HFC-SV2-01

Keyboard Wedge Synapse Cable	For Keyboard Type:
2755-HFC-SP1-01	IBM AT/XT Keyboard (5-pin DIN)
2755-HFC-SP2-01	PS/2 Keyboard (6-pin Mini-DIN)
2755-HFC-SV1-01	DEC VT220/320/420
2755-HFC-SV2-01	DEC VT520

A separate power supply plugs into the Synapse cable and provides power to the scanner. The following wedge cable applications may not require the power supply if the host provides adequate power for the scanner (depends on system configuration):

- IBM PC/AT
- IBM PS / 2-50, 55SX, 60, 70, 80
- IBM PC/XT and compatibles
- IBM PS/2-30

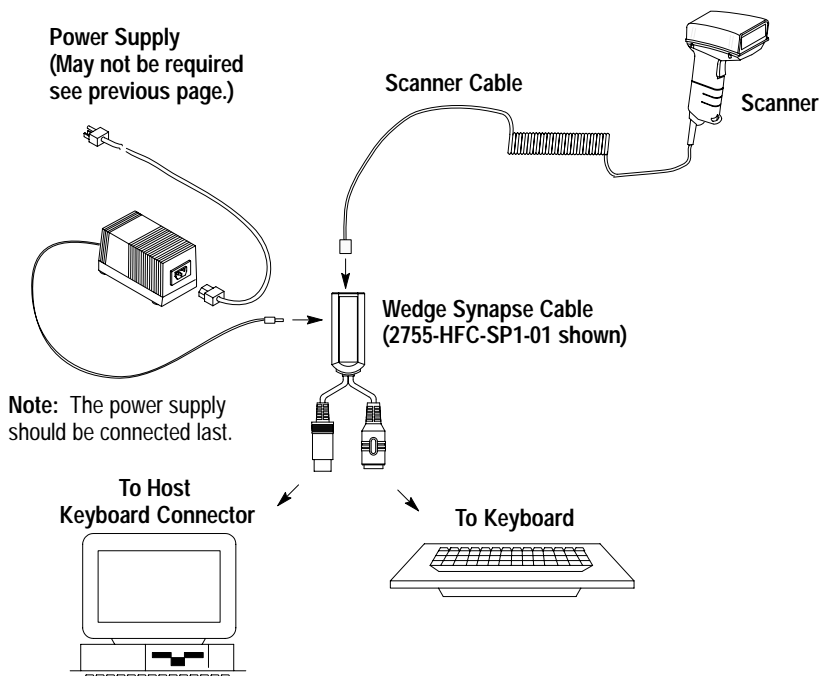

To connect the scanner cable to the keyboard wedge cable, push the cable into the connector until you hear the connector snap in place. To remove the scanner cable, press down on the small raised bump on the connector end and remove cable.



ATTENTION: Do not install the wedge cable or disconnect/connect the keyboard with power applied to either the wedge cable or host device. Failure to follow this caution may result in damage to the scanner, wedge interface cable, or host device.

The wedge Synapse cable connects between the keyboard and the host device. Unplug the keyboard and connect one end of the wedge cable to the host keyboard input. Connect the other end of the wedge interface cable to the keyboard.

AdaptaScan Pass Through Cable Connection

The standard Pass Through cable has a 25 pin male DB connector. When connecting the cable to an AdaptaScan RS-232 terminal block, you will need to attach an unterminated cable with a female 25 pin DB connector on one end. Power for the scanner is provided by the package detect terminal block connector.

Important: Power for the scanner (from Package Detect terminals) is not provided until the Reader is installed on the wiring base.

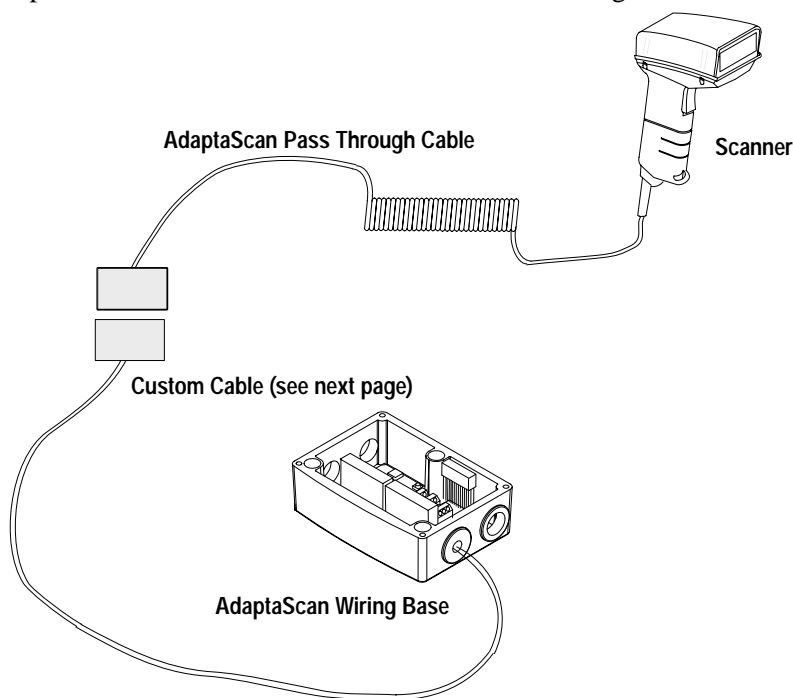

ATTENTION: Turn off all power to the AdaptaScan wiring base before making cable connections. Failure to follow this caution could result in electrical shock and/or damage to the scanner or AdaptaScan wiring base.

The custom cable for the AdaptaScan Pass Through cable connects to the RS-232 and package detect terminals in the AdaptaScan wiring base.

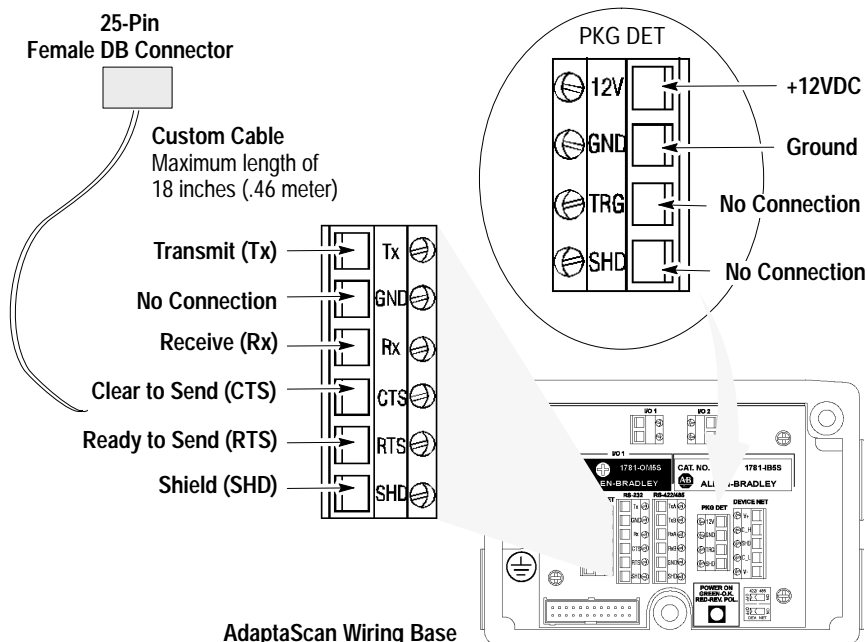

The following table provides the pinout connections for the cable (DB 25-pin female connector).

Pass Through Cable Pin Number (DB25 Connector)	Function	AdaptaScan Terminal Connection
2	Receive Data Input	Tx (RS-232 Terminal Block)
3	Transmit Data Output	Rx (RS-232 Terminal Block)
4	CTS Input	RTS (RS-232 Terminal Block)
5	RTS Output	CTS (RS-232 Terminal Block)
7	Ground	GND (Package Detect Terminal Block)
9	+V 4.8 to 14.0V DC	12V (Package Detect Terminal Block)
Shield	Shield Ground	SHD (RS-232 Terminal Block)

Scanner to Enhanced Decoder Scanner Port Application

Use the Scanner Emulation Synapse cable (Catalog No. 2755-HFC-SA1-01) and Gun Adapter (Catalog No. 2755-NC16, Series B) to connect the scanner cable to a scanner port on the Allen-Bradley Enhanced Decoders (2755-DS1/DD1).

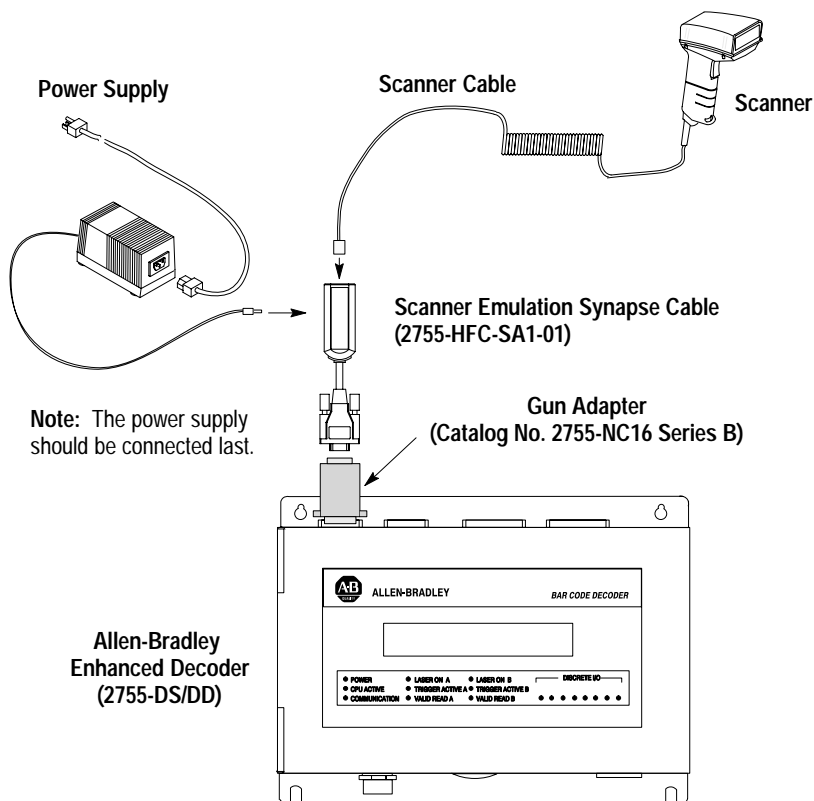

ATTENTION: Use the Series B Gun Adapter (Catalog No. 2755-NC16, Series B). The Series A Gun Adapter was designed for earlier versions of the hand-held scanners (such as 2755-G2, -G3) and will not work with the new hand-held scanners.

Scanner to Enhanced Decoder Aux Port Application

Use the 25-pin RS-232 Synapse cable (Catalog No. 2755-HFC-SR2-01) to connect the scanner cable to a Aux port on the Allen-Bradley Enhanced Decoders (2755-DS1/DD1).

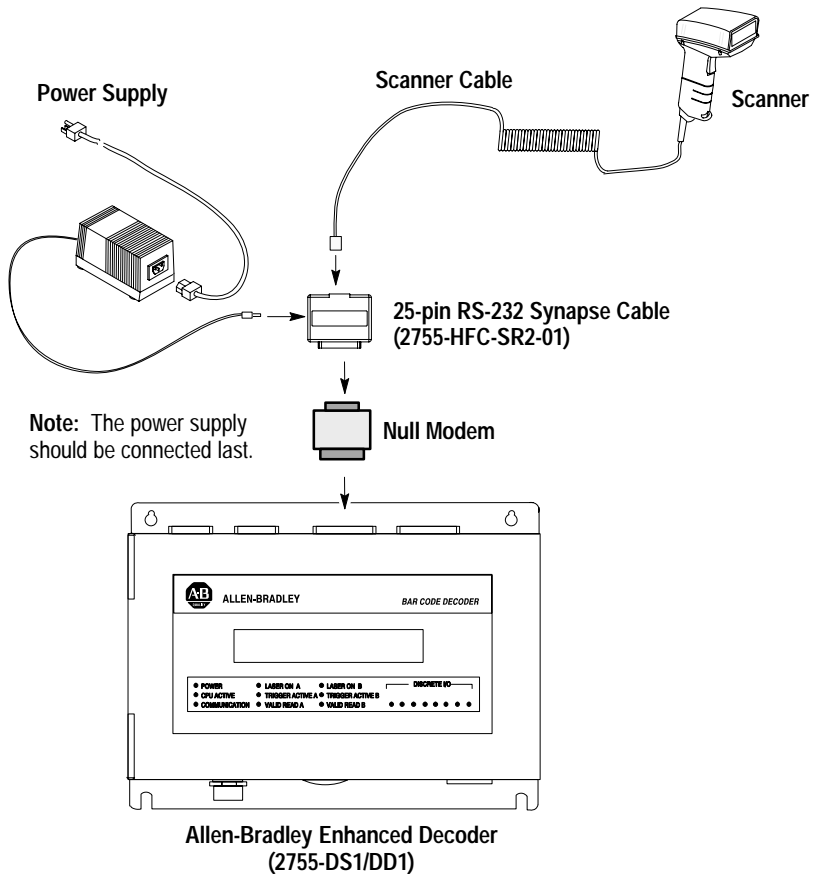

Scanner to Flexible Interface (RB) Module Application

Use the 25-Pin RS-232 Synapse cable (Catalog No. 2755-HFC-SR2-01) to connect the scanner cable to a port on the Flexible Interface Module (Catalog No. 2760-RB). The protocol cartridges (Catalog No. 2760-SFC1, -SFC2) support RS-232 communications.

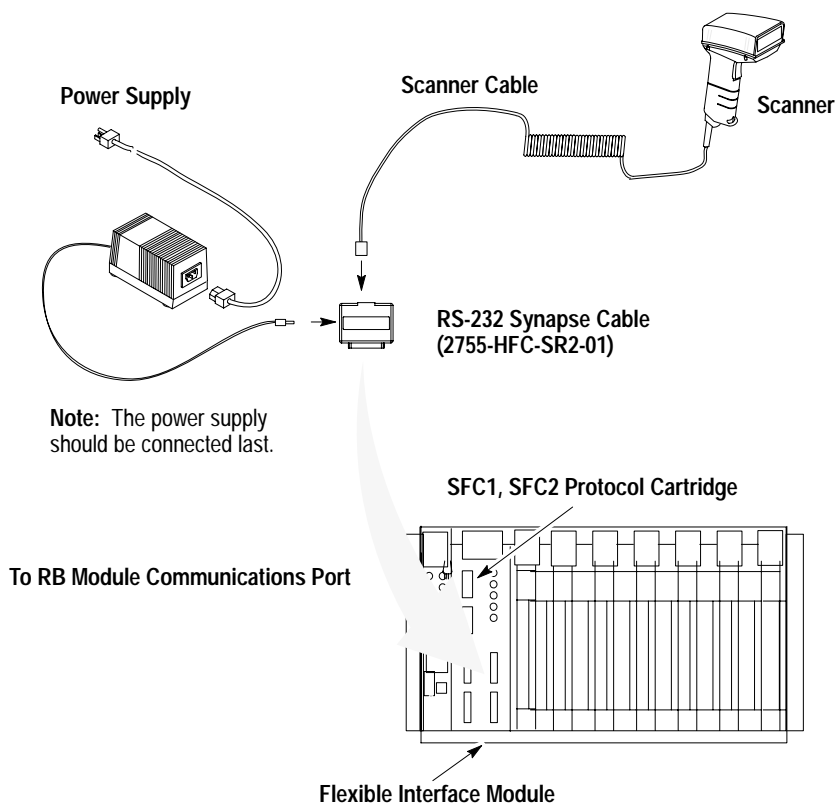

Refer to the user manual for the Flexible Interface Module for the proper configuration. Make sure the Synapse cable communications settings match the Flexible Interface Module settings for the port.

Scanner to PLC Application

Use the 25-Pin RS-232 Synapse cable (Catalog No. 2755-HFC-SR2-01) to connect the scanner cable to the channel 0 port on a PLC-5. The channel 0 port must be configured for RS-232 communications.

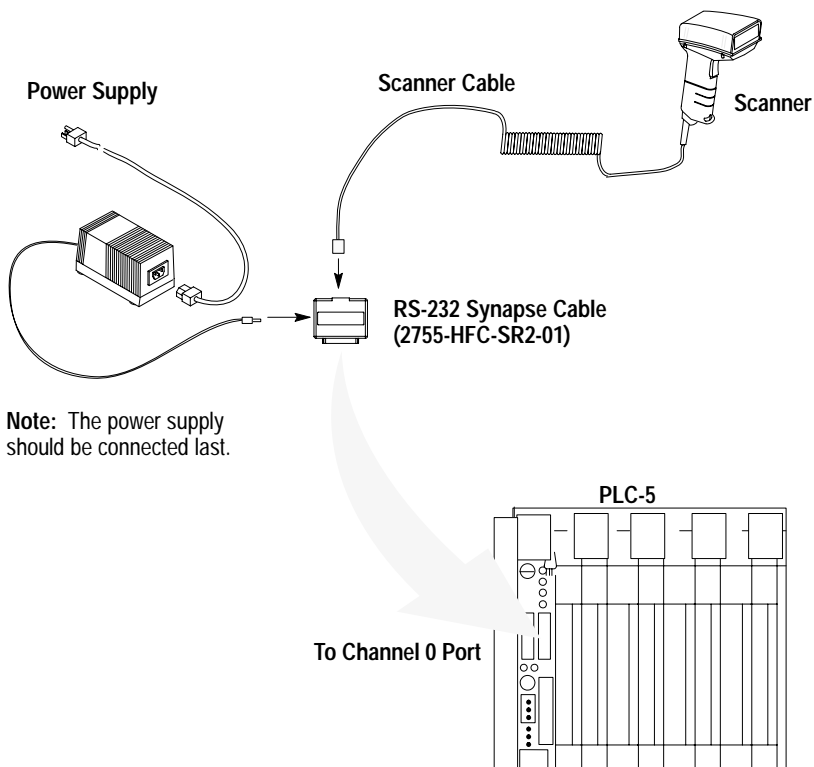

Refer to the user manuals for the Allen-Bradley 6200 Series Programming Software to make sure the channel 0 settings match the Synapse cable settings.

Scanner to SLC Application

Use the 9-Pin RS-232 Synapse cable (Catalog No. 2755-HFC-SR3-01) to connect the scanner cable to the channel 0 port on an SLC-5/03 or 5/04. The channel 0 port must be configured for RS-232 communications.

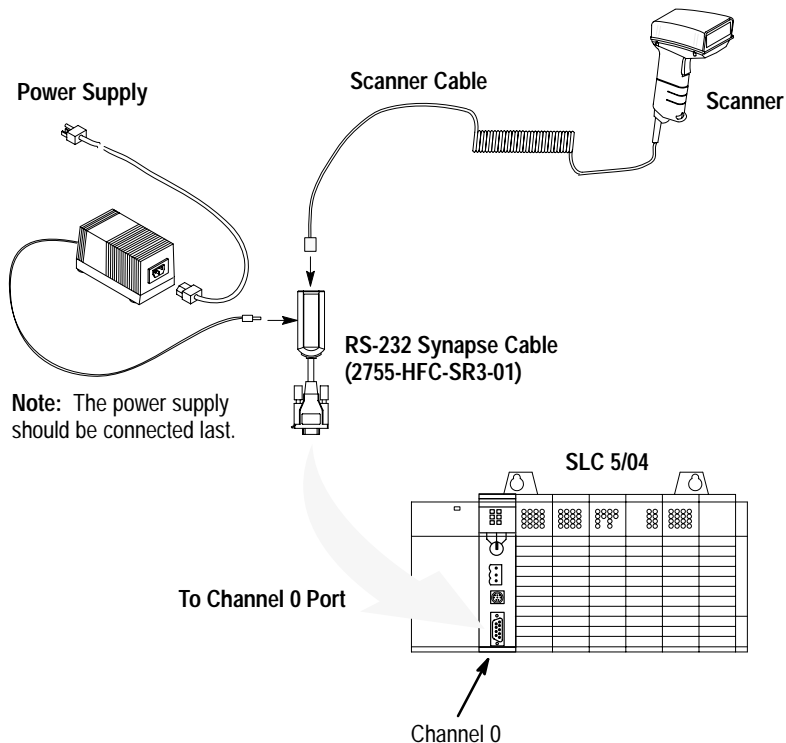

Refer to the user manuals for the Allen-Bradley Advanced Programming Software (APS) to make sure the channel 0 settings match the Synapse cable settings.

Operating the Scanner

1. Check your connections.

- Is the scanner cable securely attached?
- Is the scanner cable securely connected to the Synapse cable?
- If a power supply is required, is there power to the power supply and is the power supply plugged into the Synapse cable?

2. Test the scanner

Aim the scanner at the work surface and press the trigger. You should see the red beam on the work surface, and the red LED on the back of the scanner should be on.

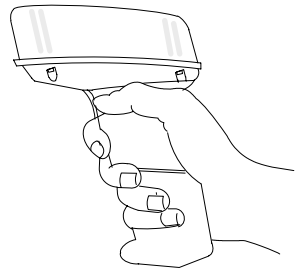

3. Scan a label.

Scan a bar code. Adjust the scanner position so that the scan beam is centered on the bar code and overlaps both sides. When the scanner has read a symbol:

- You will hear a beep from the scanner (if symbology has been enabled, all symbologies enabled at default).
- The green LED will turn on and remain on until the next scan.

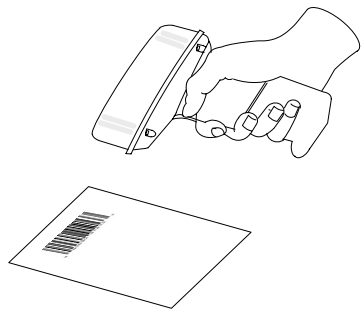

Automatic Shutoff

The scanner automatically stops scanning after a bar code symbol has been read. The length of time the scanner remains on without reading a label is configurable from 0.5 to 3 seconds. You must release and press the trigger again to resume scanning.

Audible Response

When scanning a bar code symbol, listen for a single short beep from the scanner. This beep indicates that the bar code has been successfully scanned. Refer to the following tables for all other responses:

Beep During Normal Operation

This Response	Indicates
1 Beep (short high tone)	Bar code symbol decoded. Scanner audible response must be enabled.
4 Beeps (long, low tone)	Format or transmission error detected. This error occurs if the scanner is not properly configured. All data is ignored. Verify option settings.

Beep During Configuration

This Response	Indicates
1 Beep (short high tone)	Bar code symbol decoded. Scanner audible response must be enabled.
1 Beep (low / high tone)	Input error. Possible causes: Incorrect bar code scanned Cancel scanned Incorrect configuration sequence
1 Beep (high / low tone)	Bar code scanned requiring a value. Scan in the value using the configuration bar codes.
1 Beep (high / low / high / low tone)	Configuration setting successfully changed.

Beep During Code 39 Buffering

This Response	Indicates
1 Beep (high / low tone)	New Code 39 data entered into the buffer.
3 Beeps (long high tone)	Code 39 buffer is full.
1 Beep (low / high / low tone)	Buffer cleared or an attempt to transmit an empty buffer occurred.
2 Beeps (long high tone)	Error in data transmission, check cable connections.
1 Beep (low / high tone)	Transmission of buffer data successful.

Configuring the Scanner and Cables

Configure the scanner, Synapse and AdaptaScan Pass Through cables by scanning the bar codes in the Bar Code Programming Guide for Decoded Hand-Held Scanners (Publication 2755-6.5). The scanner is always enabled to read the Code 128 configuration bar codes used for configuring the scanner. Refer to:

- Scanner Configuration (Chapter 3)
- Communication Setup, Cable Configuration (Chapter 4)

Configuring the Scanner

This chapter describes the scanner configuration options.

Important Notes on Configuring a Scanner

Be aware of the following when configuring the scanner:

- Both the scanner and Synapse cable configuration bar codes are located in the Bar Code Programming Guide for Hand-Held Scanners (Publication 2755-6.5).
- Configure the scanner for use with a Synapse cable or AdaptaScan Pass Through cable. Separate scanner configuration codes are used for each cable type. Make sure you use the correct configuration codes. The programming guide has separate tabbed sections for Scanner Configuration (for Synapse Cable) and Scanner Configuration (for AdaptaScan Pass Through Cable)
- Chapter 4 describes the communication setup (cable configuration) codes for the RS-232, keyboard wedge cable, scanner emulation, and AdaptaScan Pass Through cables.

Scanner Configuration Bar Codes

All programming codes may be found in the Bar Code Programming Guide for Hand-Held Scanners (Publication 2755-6.5). The scanner is always enabled to read Code 128 configuration labels since all configuration codes use this symbology.

Configuring the Scanner

1. Connect the interface cable to the scanner.
2. Apply power to the interface cable (if required).
3. Scan the SCAN THIS SYMBOL FIRST bar code (found in Bar Code Programming Guide, see page references below).
4. Then scan the SET SCANNER FOR (SYNAPSE or ADAPTASCAN) CABLE OPERATION bar code.
5. Select the scanner cable type. Scan ENABLE SYNAPSE CABLE if you are using one of the Synapse cables (RS-232, keyboard wedge, or scanner emulation). Scan the ENABLE ADAPTASCAN PASS THROUGH CABLE bar code if you are using the AdaptaScan Pass Through cable (Catalog No. 2755-HDC-GA2-08).

Note: The scanner stores the Synapse cable and AdaptaScan pass through cable configurations separately. To change between configurations, scan the ENABLE SYNAPSE CABLE or ENABLE ADAPTASCAN PASS THROUGH CABLE bar code.

6. Configure the scanner by scanning the bar codes for the options you want to change. The scanner is currently set with default settings as listed on this and the following page.

Scanner Default Settings

Item	Default Setting	Programming Guide ① Page Reference	
		For AdaptaScan Cable	For All Other Cables
Cable Type	AdaptaScan Pass Through Cable	2-2	1-2
Symbologies	All Enabled	2-4	1-4
Transmit UPC-A Check Digit	Enabled	2-8	1-8
Transmit UPC-E Check Digit	Enabled	2-8	1-8
Convert UPC-E to UPC-A	Disabled	2-8	1-8
EAN Zero Extend	Disabled	2-9	1-9

Item	Default Setting	Programming Guide ① Page Reference	
		For AdaptaScan Cable	For All Other Cables
Decode UPC / EAN Supplemental	Disabled	2-9	1-9
UPC-A Preamble	System Character	2-10	1-10
UPC-E Preamble	System Character	2-10	1-10
UPC/EAN Security Level	0	2-11	1-11
CLSI Editing	Disabled	2-12	1-12
NOTIS Editing	Disabled	2-12	1-12
Codabar Decode Redundancy	Disabled	2-12	1-12
Transmit Code 39 Check Digit	Disabled	2-13	1-13
Buffer Code 39	Disabled	2-13	1-13
Code 39 Full ASCII	Disabled	2-13	1-13
MSI Plessey Check Digit	One	2-14	1-14
MSI Plessey 2 Check Digit Algorithm	Mod 10 - Mod 10	2-14	1-14
Convert Interleaved 2 of 5 (14 digit) to EAN 13	Disabled	2-15	1-15
Interleaved 2 of 5 Code Length	14	2-15	1-15
Discrete 2 of 5 Code Length	12	2-15	1-15
Prefix	None	2-17	1-17
Suffix	None	2-17	1-17
Data Transmission Format	②	2-19	1-19
Transmit No-Read Message	Disabled	2-19	1-20
Transmit Code ID Character	Disabled	2-20	1-20
Transmit Alm ID Character	Disabled	2-20	1-21
Audible Response	Enabled	2-21	1-21
Power Mode	③	2-21	1-21
Laser On Timeout	3 Seconds	2-22	1-22
Hands-Free Operation Timeout	60 minutes	2-24	1-23

① Bar Code Programming Guide for Decoded Scanners (Publication No. 2755-6.5)

② for AdaptaScan Cable = Suffix Only, for Synapse Cable = Data As Is

③ for AdaptaScan Cable = Low Power, for Synapse Cable = Continuous

Select Cable Type

Important: Select the cable type before configuring the scanner. The scanner configuration codes (and some options) for each cable type (Synapse and AdaptaScan Pass Through) are different. Each configuration is stored separately. The selections are:

- Enable Synapse Cable
- Enable AdaptaScan Pass Through Cable (default)

After configuring the scanner, you can switch between configurations by scanning the cable selection bar code.

Select Symbologies

Scan the bar code labels for the symbologies you want the scanner to decode. Only enable the symbologies you expect to read. The scanner automatically discriminates between all of the following symbologies. The only exception is that the scanner cannot discriminate between Code 39 and Code 39 Full ASCII. The scanner can read and decode the following symbologies. All symbologies are enabled by default.

UPC-A	UPC-E
Code 39	Code 39 Full ASCII
EAN 8	EAN 13
Interleaved 2 of 5	Discrete 2 of 5
Codabar	Code 128
MSI / Plessey	Code 93
EAN 128	

To enable a symbology, scan the ENABLE bar code for the symbology. To disable a symbology, scan the DISABLE bar code.

UPC / EAN Options

The following options are available for UPC-A and UPC-E codes:

Transmit UPC-A Check Digit

When enabled, UPC-A symbol data is transmitted with the check digit. Enabled is the default.

Transmit UPC-E Check Digit

When enabled, UPC-E symbol data is transmitted with the check digit. Enabled is the default.

Convert UPC-E to UPC-A

When enabled, this option converts UPC-E (zero suppressed) decoded data to a UPC-A format before sending the data. After conversion, output data will be affected by UPC-A programming selections such as preamble and check digit settings. Disabled is the default.

Decode UPC / EAN Supplemental

When enabled, supplemental digits are decoded. If the supplemental digits are not enabled and a symbol having supplemental digits is read, the supplemental digits are ignored. On the other hand, if supplemental digits are enabled, only symbols with supplemental digits are decoded. Disabled is the default.

Autodiscriminate UPC / EAN with Supplementals

When enabled, supplemental digits are decoded. Both codes with and without supplemental digits are decoded. Disabled is the default.

UPC / EAN Options (Continued)

EAN 8 Zero Extend

When enabled, five leading zeros are added to decoded EAN 8 symbol data. The five zeros make the EAN 8 symbols compatible with the EAN 13 format. Disabled is the default.

UPC-A / UPC-E Preambles

The UPC preamble consists of the system character and country code. The system character is the the first character on the left side of the symbol. The country code for UPC is always 0. Select whether these characters are sent with the bar code data. System character is the default.

- system character only
- country code and system character
- no preamble

Note: There are separate preamble programming codes for both UPC-A and UPC-E symbols.

UPC / EAN Decode Security Levels

There are four levels of decode security. There is an inverse relationship between security and the ability to decode codes of varying quality. Increasing the security level, “tightens” the scanner’s requirements for a valid read. Select one of the levels below.

The default security level is 0. This level is sufficient for most applications. Higher security levels:

- may result in more no-reads on poor quality labels
- reduce the chance of mis-reads on poor quality labels

Security Level	Decode Operation
0	At the level 0, the scanner decodes many poor or low quality codes while providing adequate security for UPC/EAN codes within specifications.
1	As the quality level of UPC / EAN bar codes decrease, certain digits are more susceptible to misreads (1, 2, 7, 8) If you have problems only decoding symbols with these digits, select this security level.
2	If you are having problems decoding poor quality bar codes and the problem isn't limited to the digits (1, 2, 7, 8), select this level.
3	If you selected security level 2 and are still having problems decoding symbols, select this security level. Note: Only select this level if you are scanning high quality bar codes. The scanner will reject codes that are not within the specifications for the symbology.

Codabar Options

The following options are available for Codabar bar codes:

NOTIS Editing

When enabled, the scanner removes the start and stop characters from the decoded symbol data.

CLSI Editing

When enabled, the scanner removes the start and stop characters and inserts a space after the 1st, 5th, and 10th characters of a 14 character Codabar Symbol.

Note: Symbol length does not include start and stop characters.

Decode Redundancy for Codabar

When enabled, a Codabar symbol must be read in both directions before being decoded.

Code 39 Options

The following options are available for Code 39 symbols.

Code 39 Check Digit

When enabled, the scanner verifies the Code 39 check digit (modulo 43 check character).

Code 39 Buffering (Scan and Store)

When enabled, the scanner stores all Code 39 symbol data that has a leading space as the first character (following start pattern). As Code 39 labels are scanned for buffering, the scanner provides a high/low beep to indicate that the data is stored in the buffer.

Up to 250 bytes of information may be stored. If you scan a symbol and the buffer is full, the scanner will provide three long high tone beeps. No transmission will occur and the data in the buffer is not affected.

Note: Before you can disable Code 39 buffering, you must clear the buffer (see below).

Clear Transmission Buffer

Clears the Code 39 transmission buffer. You will hear a high/low/high beep after the buffer has been cleared. No data is transmitted.

Code 39 Options (Continued)

Send Transmission Buffer

Sends the contents of the Code 39 transmission buffer. You will hear a low/high beep after the buffer has been sent. You can also send the contents of the Code 39 buffer by scanning any Code 39 label with any leading character other than a space. If you attempt to transmit an empty buffer, the scanner will provide a short low/high/low beep.

Code 39 Full ASCII

The full ASCII option allows the scanner to output any ASCII character or control code (including non-printable characters). When enabled, the scanner interprets some characters (\$, +, %, /) as special control codes. Refer to Appendix E for a list of the Code 39 Full ASCII codes.

For example, scanning a symbol **\$H** results in the ASCII code for a Backspace being transmitted.

Note: The scanner cannot autodiscriminate between Code 39 and Code 39 Full ASCII symbols.

MSI Plessey Options

The following options are available for MSI Plessey codes:

MSI Plessey Check Digit

When enabled, the scanner verifies the one or two digit check character before transmitting the data. Check digits are not included in the transmitted data.

MSI Plessey 2 Check Digit Algorithm

When enabled, the scanner performs an additional verification. You must select either Mod 10 - Mod 10 (Default) or Mod 11 - Mod 11 check digits.

I 2-of-5 and Discrete 2-of-5 Options

The following options are available for Interleaved and Discrete 2 of 5 symbols:

I 2 of 5 (14 digit) to EAN 13 Conversion

When enabled, 14 character Interleaved 2 of 5 data is converted and transmitted in an EAN 13 format.

Note: Interleaved 2 of 5 must be enabled and one code length (Length 1 or Length 2) must be set to 14. In addition, the code must have a leading 0 and a valid EAN 13 check digit.

Code Lengths

Specifies the expected length of the bar code symbol. When a specific length is enabled, symbols that are not the specified length are ignored. Only one or two lengths may be specified, all other lengths are ignored.

First scan the length symbol followed by the 2 digit length. Length 1 may range from 01 to 31. Length 2 may be in the range of 00 to 31.

Determine the number of characters in a symbol by counting the number of printed digits (human readable characters).

Note: The scanner cannot be configured to read Interleaved or Discrete 2-of-5 labels of “any length”. You must specify code length(s).

Data Format Options

The following options define the what happens to the data after a symbol has been decoded:

Data Prefix / Suffix

To add prefix or suffix data to bar code data, scan the prefix or suffix bar code followed by the 4 digit ASCII equivalent value for each character (refer to Appendix D for the ASCII chart). Only one character may be specified as a suffix or prefix. When you enter the last digit of a prefix or suffix, the scanner lets you know that you have entered a valid value by providing a high-low-high beep.

Data Transmission Formats

You can set whether or not prefix or suffix data is added to the decoded symbol data. You have four options:

- **<DATA>** only bar code data is sent
- **<PREFIX> <DATA>** prefix data is sent then the bar code data
- **<DATA> <SUFFIX>** bar code data is sent then the suffix data
- **<PREFIX><DATA><SUFFIX>** prefix data is sent then bar code data followed by the suffix data

Transmit NO READ Message

When enabled, a **NR** is transmitted with each no-read. If enabled, a prefix and suffix will appear with the NR output message.

Transmit Code ID Character

The code ID identifies a scanned bar code symbol's code type. If enabled, the code ID is sent after the prefix and before the bar code data. The code ID codes are:

A = UPC-A, UPC-E, or EAN 13

B = Code 39

C = Codabar

D = Code 128

E = Code 93

F = Interleaved 2 of 5

G = Discrete 2 of 5

J = MSI Plessey

K = EAN 128

Transmit AIM ID Character

When enabled, the AIM code identifier is sent after the prefix and before the bar code data. The identifier is a three character prefix. Refer to the following:

Each AIM Code Identifier contains the 3-character string **]cm** where:

-] =** Flag Character (ASCII 93)
- c =** Code Character (see table below)
- m =** Modifier (see table on next pages)

Code Character / Generic Identifier	Code Type
A /]A0	Code 39
C /]C0	Code 128
E /]E0	UPC/EAN
I /]I0	Interleaved 2 of 5

The modifier character is the sum of the applicable option values based on the following table.

Code Type	Option Value	Option
Code 39	0	No Check character or Full ASCII processing.
	1	Reader has checked one check character.
	2	Reader has stripped check character.
	4	Reader has performed Full ASCII character conversion.
	Example:	A Full ASCII bar code 1234 with check character W, A+I+MI+DW , can be transmitted as JA7 1234 where $7 = (1+2+4)$.
Code 128	0	Standard data packet. No Function code 1 in first symbol position.
	1	Function code 1 in first symbol character position.
	2	Function code 1 in second symbol character position.
	Example:	A Code (EAN) 128 bar code 12345 with Function 1 character in the first position, F_{ent}1 12345 will be transmitted as JC1 12345.
EAN/UPC	0	Standard packet in full EAN country code format, which is 13 digits for UPC-A and UPC-E (not including supplemental data).
	1	Two digit supplement data only.
	2	Five digit supplement data only.
	4	EAN-8 data packet.
	Example:	A UPC-A bar code 012345678905 will be transmitted as JE0 0012345678905.
Interleaved 2 of 5	0	No check digit processing.
	1	Reader has checked check digit.
	2	Reader has stripped check digit before transmission.
	Example:	An I 2 of 5 bar code without check digit, 4123 will be transmitted as JIO 4123.

According to AIM standards, a UPC with supplemental bar code is transmitted in one of the following formats:

1E0 (UPC chars) (terminator) **1E2** (supplemental) (terminator) or

1E2 (supplemental) (terminator) **1E0** (UPC chars) (terminator)

In the 2755-HDG-4, however, this format is changed to:

1E0 (UPC chars) **1E2** (supplemental)

Therefore, a UPC with two supplemental characters, 01234567890510, will be transmitted as a 21-character string **1E000123456789051E110**.

Laser Control and Audible Response Options

Beep After Decode

When enabled, the scanner will beep after a symbol has been decoded. We recommend that you leave this option enabled.

Laser On Time Out

This setting determines the maximum time the scanner remains on while the trigger is pressed. The time out is programmable in 0.5 second increments from 0.5 seconds to 5.0 seconds.

Hands-Free Stand Operation Timeout

If the scanner is used with an adjustable stand (Catalog No. 2755-HFN-K1, -K2), the scanner operates without pressing the trigger. Refer to Appendix C for hands-free operation. The timeout determines how long the scanner scans for a label before reducing the scan rate and beam intensity. The scanner will resume scanning at the normal rate when a label is presented. The timeout is selectable in 15 minute intervals between 15 and 90 minutes.

Power Mode

Determines whether or not the scanner power remains on after a decode attempt. With low power mode enabled, the scanner powers down after each attempted decode. With continuous power mode enabled, the scanner remains on at all times. We recommend that you use the following settings:

- low power mode for AdaptaScan Pass Through cable
- continuous power mode for Synapse cables

Note: When the scanner is in low power mode and a label is scanned, the first character of the first symbol will not be read as the scanner powers up. Use continuous mode if this causes a problem with your application (such as stand mode or A-B Basic Module applications).

Communication Setup (Cable Configuration)

This chapter describes the configuration of scanner communication parameters. The types of options available depends on the interface cable you are using.

For This Cable	See These Pages:
RS-232 Synapse Cables	4-2 through 4-8
IBM PC Keyboard Wedge Synapse Cables	4-9 through 4-12
DEC VT520 Keyboard Wedge Synapse Cable	4-13 through 4-15
DEC VT220, VT320, VT420 Keyboard Wedge Synapse Cable	4-16 through 4-18
Scanner Emulation Synapse Cable	4-19 through 4-23
AdaptaScan Pass Through Cable	4-24 through 4-29

Important: All programming codes are in the Bar Code Programming Guide for Hand-Held Scanners (Publication 2755-6.5).

Cable Defaults

To set cable defaults, scan the default label for the interface cable you are using. Refer to each cable section for a table listing the defaults. The selections for cable defaults are:

- Set RS-232 Synapse Cable Defaults
- Set IBM PC Keyboard Wedge Synapse Cable Defaults
- Set DEC VT 520 Keyboard Wedge Synapse Cable Defaults
- Set DEC VT VT220, VT320, VT420 Wedge Synapse Cable Defaults
- Set AdaptaScan Pass Through Synapse Cable Defaults

Setting RS-232 Synapse Cable Options

The following define the communication options available when the scanner is connected to one of the following RS-232 Synapse cables:

- Catalog No. 2755-HFC-SR2-01
- Catalog No. 2755-HFC-SR3-01

Default Settings

Scanning the SET RS-232 SYNAPSE CABLE DEFAULTS bar code sets the following parameters:

Item	Default Setting	Refer to Description on Page:	Programming Guide ① Page Reference
Host	Standard RS-232	4-3	3-3
Baud Rate	9600	4-3	3-4
Parity	None	4-4	3-5
Check Parity	Enabled	4-4	3-5
Stop Bits	1	4-4	3-6
Data Bits	8	4-4	3-6
Hardware Handshaking	None	4-5	3-7
RTS State	Low	4-5	3-7
Software Handshaking	None	4-6	3-8
Beep on BEL	Enabled	4-7	3-9
Unknown Characters	Send Bar Codes With Unknown Characters	4-7	3-9
Response Timeout	2 seconds	4-7	3-10
Parameter Set	Set #1	4-8	3-12

① Bar Code Programming Guide for Decoded Scanners (Publication 2755-6.5).

Host Selection

Currently, the only host selection is for standard RS-232 communications. Additional host selections may be added in the future.

- Standard RS-232 (default)

Baud Rate

Sets the rate (bits per second) at which the scanner transmits data.

The scanner baud rate setting must match the host setting.

The selections are:

- 110
- 300
- 600
- 1200
- 2400
- 4800
- 9600 (default)
- 19200

Setting RS-232 Synapse Cable Options (Continued)

Parity

Set the parity of each ASCII coded character that is transmitted. Make sure the parity matches the requirements of the host. The selections are:

- Odd
- Even
- Mark (parity bit always set to 1)
- Space (parity bit always set to 0)
- None (default)

Check Parity

When enabled, the scanner checks the parity bit.

Number of Stop Bits

The stop bit marks the end of each character transmitted. Set the number of stop bits to match the host device. The selections are:

- 1 Stop Bit (default)
- 2 Stop Bits

Data Bits

Determines the number of data bits for each ASCII character. The selections are:

- 7 data bits
- 8 data bits (default)

Hardware Handshaking

When enabled, handshaking verifies the readiness of a receiving device before data is transmitted. You can enable or disable the hardware handshaking lines. The DTR (Data Terminal Ready) signal is either active high or low (see below).

This is how the scanner handshaking functions:

1. The scanner checks the Clear to Send (CTS) line. If CTS is active, the scanner will wait for up to 2 seconds and check the line again. If the line is still active, the scanner will provide an audible beep and any scanned data will be lost.
2. If the CTS line is not active, the scanner will assert the Request to Send (RTS) line and wait for two seconds for the host to assert the CTS line. When the host asserts the CTS line, the scanner transmits the data.
3. After the transmission is completed, the scanner will negate the RTS.
4. The host device should then negate CTS. The scanner checks the CTS line on the next transmission.

RTS State

Selects the active state for the Request to Send (RTS) signal.

Make sure that this setting matches the requirements of the host device.

The selections are:

- RTS State Low (default)
- RTS State High

Setting RS-232 Synapse Cable Options (Continued)

Software Handshaking

Software handshaking controls the transmission of data. Use software handshaking instead of (but not with) hardware handshaking. There are four options:

- None (default)
- ACK/NAK Only
- ENQ Only
- ACK/NAK with ENQ
- XON/XOFF

ACK/NAK Only checks the result of a transmission. The scanner waits for one of two responses from the host: ACK which means a successful transmission or NAK which means there was a problem. Whenever the scanner receives a NAK, it retransmits the data up to three times. If an ACK is still not received after three attempts, the transmission is aborted and the scanner will provide four short beeps.

ENQ ONLY requires that the scanner receive an enquire character (ENQ) from the host before sending data. With ENQ enabled, the scanner must receive an ENQ from the host within a two second period after the last scan or a transmission error occurs. The scanner will provide four short beeps to indicate the error.

ACK/NAK with ENQ combines both ACK/NAK and ENQ options.

With XON/ XOFF enabled, the interface cable assumes an XON for the first transmission. The scanner will transmit data until an XOFF is received from the host device. If an XON is not received within 30 seconds after an XOFF, a transmission error occurs.

Beep on BEL

When enabled, the scanner will beep when a <BEL> character is detected on the RS-232 link. <BEL> may be used to indicate an event such as an illegal entry.

Unknown Characters

Unknown characters are characters not recognized by the scanner. When SEND BAR CODES WITH UNKNOWN CHARACTERS is enabled, all decoded bar code data is transmitted except for the unknown characters. If this option is disabled, bar codes containing one or more unknown characters are not transmitted.

Response Timeout

The response timeout determines the maximum amount of time the scanner will wait before it assumes the end of a transmission. The timeout period may be from 0.0 to 9.9 seconds in 0.1 second increments. The default is 2.0 seconds.

To enter a new timeout, scan the timeout label followed by the two digit timeout. The decimal point is fixed between the first and second digits.

Setting RS-232 Synapse Cable Options (Continued)

Advanced Features

The advanced feature options allow you to store communication parameters for up to two applications. If you have already configured the scanner, all of the communication settings are stored as Parameter 1 settings (default setting). Using the advanced feature options, you can also create Parameter 2 settings. When using the scanner, scan the correct parameter setting bar code to configure the scanner for each application.

To set Parameter Set 1 configuration:

1. Configure the scanner communications as described in this chapter. Since Parameter Set 1 is the default you do not have to scan the Parameter Set 1 bar code.

To set Parameter Set 2 configuration:

1. Scan the PARAMETER SET 2 bar code.
2. Configure the scanner communication parameters as described in this chapter.

To set defaults for a parameter set, scan the appropriate default bar code. The selections are:

- SET CABLE DEFAULTS CURRENT PARAMETER SET
- SET CABLE DEFAULTS BOTH PARAMETER SETS

Setting IBM PC Keyboard Wedge Synapse Cable Options

The following define the communication options available when the scanner is connected to one of the following IBM AT/XT or PS/2 keyboard wedge Synapse cables:

- Catalog No. 2755-HFC-SP1-01
- Catalog No. 2755-HFC-SP2-01

Defaults Settings

Scan the SET PC WEDGE SYNAPSE CABLE DEFAULTS bar code to set the interface cable to default settings. The following table lists the default settings.

Item	Default Setting	Refer to Description on Page:	Programming Guide ① Page Reference
Host	IBM PC/AT IBM PS/2-50, 55SX, 60, 70, 80	4-10	4-2
Country	North American	4-10	4-3
Bar Codes with Unknown Characters	Send Bar Codes With Unknown Characters	4-11	4-4
Intercharacter Delay	5 milliseconds	4-11	4-4
Parameter Set	Parameter Set 1	4-12	4-5

① Bar Code Programming Guide for Decoded Scanners (Publication 2755-6.5).

Setting IBM PC Keyboard Wedge Interface Synapse Cable Options (Continued)

Host Selection

Select the type of host the scanner will be communicating with.

The selections are:

- IBM PC/AT , PS/2-50, 55SX, 60, 70, 80 (default)
- IBM PC/XT
- IBM PS/2-30
- NCR 7052

Country Selection

Select the country for the keyboard type the interface cable is connected to. The selections are:

- North American (default)
- German
- French
- French International
- Spanish
- Italian
- Swedish
- British

Unknown Characters

Unknown characters are characters not recognized by the scanner. When SEND BAR CODES WITH UNKNOWN CHARACTERS is enabled (default), all decoded bar code data is transmitted except for the unknown characters. If this option is disabled, bar codes containing one or more unknown characters are not transmitted.

Intercharacter Delay

Setting an intercharacter delay provides the host time to perform processing tasks between characters. The default is short delay (5 msec). The options are:

- Short 5 msec delay (default)
- Medium 50 msec delay
- Long 99 msec delay

Setting IBM PC Keyboard Wedge Interface Synapse Cable Options (Continued)

Advanced Features

The advanced feature options allow you to store communication parameters for up to two applications. If you have already configured the scanner, all of the communication settings are stored as Parameter 1 settings (default setting). Using the advanced feature options, you can also create Parameter 2 settings. When using the scanner, scan the correct parameter setting bar code to configure the scanner for each application.

To use and/or set Parameter Set 1 configuration:

1. Configure the scanner communications as described in this chapter. Since Parameter Set 1 is the default you do not have to scan the Parameter Set 1 bar code.

To use and/or set Parameter Set 2 configuration:

1. Scan the PARAMETER SET 2 bar code.
2. Configure the scanner communication parameters as described in this chapter.

To set defaults for a parameter set, scan the appropriate default bar code. The selections are:

- SET CABLE DEFAULTS CURRENT PARAMETER SET
- SET CABLE DEFAULTS BOTH PARAMETER SETS

Setting DEC VT520 Keyboard Wedge Synapse Cable Options

The following define the communication options available when the scanner is connected to one of the following DEC keyboard wedge Synapse cable:

- Catalog No. 2755-HFC-SV2-01

Default Settings

Scan the SET DEC VT 520 KEYBOARD WEDGE SYNAPSE CABLE DEFAULTS bar code to set the interface cable to default settings. Refer to the table below for the default settings.

Item	Default Setting	Refer to Description on Page:	Programming Guide ^① Page Reference
Host	DEC VT520	4-14	5-2
Country	North American	4-14	5-2
Unknown Characters	Send Bar Codes With Unknown Characters	4-14	5-4
Intercharacter Delay	5 Millisecond	4-15	5-4
Parameter Set	Parameter Set 1	4-15	5-5

^① Bar Code Programming Guide for Decoded Scanners (Publication 2755-6.5).

Setting DEC VT520 Keyboard Wedge Interface Synapse Cable Options (Continued)

Host Selection

Select the type of host the scanner will be communicating with.
The selections are:

- DEC VT520 (default)
- DEC VT520 with PS/2 Keyboard

Country Selection

Select the country for the keyboard type the interface cable is connected to. The selections are:

- North American (default)
- German
- French
- French International
- Spanish
- Italian
- Swedish
- British

Unknown Characters

Unknown characters are characters not recognized by the scanner. When SEND BAR CODES WITH UNKNOWN CHARACTERS is enabled (default), all decoded bar code data is transmitted except for the unknown characters. If this option is disabled, bar codes containing one or more unknown characters are not transmitted.

Intercharacter Delay

Some devices require a delay between characters to simulate the effect of keystroke delays (characters are sent at a lower rate). The default is short delay (5 msec). The options are:

- Short 5 msec delay (default)
- Medium 50 msec delay
- Long 99 msec delay

Advanced Features

The advanced feature options allow you to store communication parameters for up to two applications. If you have already configured the scanner, all of the communication settings are stored as Parameter 1 settings (default setting). Using the advanced feature options, you can also create Parameter 2 settings. When using the scanner, scan the correct parameter setting bar code to configure the scanner for each application.

To set Parameter Set 1 configuration:

1. Configure the scanner communications as described in this chapter. Since Parameter Set 1 is the default you do not have to scan the Parameter Set 1 bar code.

To set Parameter Set 2 configuration:

1. Scan the PARAMETER SET 2 bar code.
2. Configure the scanner communication parameters as described in this chapter.

To set defaults for a parameter set, scan the appropriate default bar code. The selections are:

- SET DEFAULTS CURRENT PARAMETER SET
- SET DEFAULTS BOTH PARAMETER SETS

Setting DEC VT220 / VT320 / VT420 Keyboard Wedge Synapse Cable Options

The following define the communication options available when the scanner is connected to the following DEC keyboard wedge interface cable:

- Catalog No. 2755-HFC-SV1-01

Default Settings

Scan the SET DEC VT 220/320/420 WEDGE SYNAPSE CABLE DEFAULTS bar code to set the interface cable to default settings. The table below lists the defaults.

Item	Default Setting	Refer to Description on Page:	Programming Guide ① Page Reference
Host	DEC VT220 / 320	4-16	6-2
Country	North American	4-17	6-2
Unknown Characters	Send Bar Codes With Unknown Characters	4-17	6-4
Intercharacter Delay	5 Millisecond	4-17	6-4
Parameter Set	Parameter Set 1	4-18	6-5

① Bar Code Programming Guide for Decoded Scanners (Publication 2755-6.5).

Host Selection

Select the type of host the scanner will be communicating with. The selections are:

- DEC VT 220/320 (default)
- DEC VT420

Country Selection

Select the country for the keyboard type the interface cable is connected to. The selections are:

- North American (default)
- German
- French
- French International
- Spanish
- Italian
- Swedish
- British

Unknown Characters

Unknown characters are characters not recognized by the scanner. When **SEND BAR CODES WITH UNKNOWN CHARACTERS** is enabled (default), all decoded bar code data is transmitted except for the unknown characters. If this option is disabled, bar codes containing one or more unknown characters are not transmitted.

Intercharacter Delay

Some devices require a delay between characters to simulate the effect of keystroke delays (characters are sent at a lower rate). The default is short delay (5 msec). The options are:

- Short 5 msec delay (default)
- Medium 50 msec delay
- Long 99 msec delay

Setting DEC VT220 / VT320 / VT420 Keyboard Wedge Synapse Cable Options (Continued)

Advanced Features

The advanced feature options allow you to store communication parameters for up to two applications. If you have already configured the scanner, all of the communication settings are stored as Parameter 1 settings (default setting). Using the advanced feature options, you can also create Parameter 2 settings. When using the scanner, scan the correct parameter setting bar code to configure the scanner for each application.

To set Parameter Set 1 configuration:

1. Configure the scanner communications as described in this chapter. Since Parameter Set 1 is the default you do not have to scan the Parameter Set 1 bar code.

To set Parameter Set 2 configuration:

1. Scan the PARAMETER SET 2 bar code.
2. Configure the scanner communication parameters as described in this chapter.

To set defaults for a parameter set, scan the appropriate default bar code. The selections are:

- SET CABLE DEFAULTS CURRENT PARAMETER SET
- SET CABLE DEFAULTS BOTH PARAMETER SETS

Setting Scanner Emulation Synapse Cable Options

The following define the communication options available when the scanner is connected to the following scanner emulation interface cable:

- Catalog No. 2755-HFC-SA1-01

Default Settings

Scan the SET SCANNER EMULATION CABLE DEFAULTS bar code to set the interface cable to default settings. Refer to the table below for the default settings.

Item	Default Setting	Refer to Description on Page:	Programming Guide ^① Page Reference
Emulation	Standard	4-20	7-2
Leading Margin	80 Millisecond	4-20	7-3
Decode LED	Enabled	4-20	7-3
Emulation Timeout	3 Seconds	4-21	7-4
Polarity	Margin Low / Bar High	4-21	7-5
Unknown Characters	Send Bar Codes with Unknown Characters	4-21	7-5
ConvertAlltoCode39	Disabled	4-22	7-6
Code 39 to Code 39 Full ASCII	Disabled	4-22	7-6
Parameter Set	Parameter Set 1	4-23	7-7

^① Bar Code Programming Guide for Decoded Scanners (Publication 2755-6.5).

Setting Scanner Emulation Synapse Cable Options (Continued)

Emulation

Select the type of emulation your decoder requires.

The selections are:

- Standard Emulation (default)
- MSI Wand Emulation
- Texlon Wand Emulation
- Norand Wand Emulation

Variable Leading Margin

Sets the leading margin for wand emulation. The leading margin can be varied to allow more time for the decoder to wake up before the bar code data is received. The selections are:

- 80 msec (default)
- 140 msec
- 200 msec

Check for Decode LED

When enabled (default), a transmission error occurs if the decode LED line from the host is not active.

Emulation Timeout

Determines how long:

- the interface cable waits for the laser on signal from the scanner after the trigger is pulled.
- the scanner waits for a decode LED (check if Decode LED is enabled).

These are the options:

- 3 second timeout (default)
- 4 second timeout
- 5 second timeout
- 10 second timeout
- 30 second timeout

Polarity

Sets the polarity of the wand emulation signal. The selections are:

- Margin Low / Bar High (default)
- Margin High / Bar Low

Unknown Characters

Unknown characters are characters not recognized by the scanner. When **SEND BAR CODES WITH UNKNOWN CHARACTERS** is enabled, all decoded bar code data is transmitted except for the unknown characters. If this option is disabled, bar codes containing one or more unknown characters are not transmitted.

Setting Scanner Emulation Synapse Cable Options (Continued)

Convert All to Code 39

When enabled, decoded data is converted and transmitted as Code 39 data.

Note: ASCII from the scanner is transmitted as Code 39 data.

Code 39 to Code 39 Full ASCII

When enabled, Code 39 data is transmitted as Code 39 Full ASCII. The full ASCII option allows the scanner to output any ASCII character or control code (including non-printable characters). Refer to Appendix E for a list of the Code 39 Full ASCII codes.

Advanced Features

The advanced feature options allow you to store communication parameters for 2 separate applications. If you have already configured the scanner, all of the communication settings are stored as Parameter 1 settings (default setting). Using the advanced feature options, you can also create Parameter 2 settings. When using the scanner, scan the correct parameter setting bar code for each application.

To select and/or set Parameter Set 1 configuration:

1. Configure the scanner communications as described in this chapter. Since Parameter Set 1 is the default you do not have to scan the Parameter Set 1 bar code.

To set Parameter Set 2 configuration:

1. Scan the PARAMETER SET 2 bar code.
2. Configure the scanner communication parameters as described in this chapter.

To select and/or set defaults for a parameter set, scan the appropriate default bar code. The selections are:

- SET CABLE DEFAULTS CURRENT PARAMETER SET
- SET CABLE DEFAULTS BOTH PARAMETER SETS

AdaptaScan Pass Through Cable Options

The following define the communication options available when the scanner is connected to the AdaptaScan pass through cable.

- Catalog No. 2755-HDC-GA2-08

Default Settings

Scan the SET ADAPTASCAN PASS THROUGH CABLE DEFAULTS bar code to set the default settings. The table below lists the defaults.

Item	Default Setting	Refer to Description on Page:	Programming Guide ^① Page Reference
Baud Rate	9600	4-25	2-26
Parity	Even ^②	4-25	2-27
Stop Bits	2 ^②	4-26	2-28
Data Bits	7 ^②	4-26	2-28
Hardware Handshaking	None	4-27	2-29
Software Handshaking	None	4-28	2-30
Beep on BEL	Disabled	4-29	2-31
Intercharacter Delay	0	4-26	2-32

① Bar Code Programming Guide for Decoded Scanners (Publication 2755-6.5).

② We recommend that you set Parity = None, Stop Bits = 1, and Data Bits = 8 for communication with the AdaptaScan Bar Code Reader.

Baud Rate

Sets the rate (bits per second) at which the scanner transmits data. The scanner baud rate setting must match the host setting. The selections are:

- 600
- 1200
- 2400
- 4800
- 9600 (default)
- 19200

Parity

Set the parity of each ASCII coded character that is transmitted. Make sure the parity matches the requirements of the host. The selections are:

- Odd
- Even (default)
- Mark (parity bit always set to 1)
- Space (parity bit always set to 0)
- None

Note: We recommend that you set the parity to None when communicating with an AdaptaScan Bar Code Reader.

AdaptaScan Pass Through Cable Options (Continued)

Number of Stop Bits

The stop bit marks the end of each character transmitted. Set the number of stop bits to match the host device. The selections are:

- 1 Stop Bit
- 2 Stop Bits (default)

Note: We recommend that you set the number of stop bits to 1 when communicating with an AdaptaScan Bar Code Reader.

Data Bits

Determines the number of data bits for each ASCII character. The selections are:

- 7 data bits (default)
- 8 data bits

Note: We recommend that you set the number of data bits to 8 when communicating with an AdaptaScan Bar Code Reader.

Intercharacter Delay

Some devices require a delay between characters to process data (characters are sent at a lower rate). The default is 00 milliseconds, you can enter a value between 00 and 99 milliseconds.

Hardware Handshaking

When enabled, handshaking verifies the readiness of a receiving device before transmitting data. You can enable or disable the hardware handshaking lines.

This is how the scanner handshaking functions:

1. The scanner checks the Clear to Send (CTS) line. If CTS is active, the scanner will wait for up to 2 seconds and check the line again. If the line is still active, the scanner will provide an audible beep and any scanned data will be lost.
2. If the CTS line is not active, the scanner will assert the Request to Send (RTS) line and wait for two seconds for the host to assert the CTS line. When the host asserts the CTS line, the scanner transmits the data.
3. After the transmission is completed, the scanner negates the RTS.
4. The host device should then negate CTS. The scanner checks the CTS line on the next transmission.

AdaptaScan Pass Through Cable Options (Continued)

Software Handshaking

Software handshaking controls the transmission of data. Use software handshaking instead of (but not with) hardware handshaking.

There are four options:

- None (default)
- ACK/NAK Only
- ENQ Only
- ACK/NAK with ENQ
- XON/XOFF

ACK/NAK Only checks the result of a transmission. The scanner waits for one of two responses from the host: ACK which means a successful transmission or NAK which means there was a problem. Whenever the scanner receives a NAK, it retransmits the data up to three times. If an ACK is still not received after three attempts, the transmission is aborted and the scanner provides four short beeps.

ENQ ONLY requires that the scanner receive an enquire character (ENQ) from the host before sending data. With ENQ enabled, the scanner must receive an ENQ from the host within a two second period after the last scan or a transmission error occurs. The scanner provides four short beeps to indicate an error (ENQ not received).

ACK/NAK with ENQ combines both ACK/NAK and ENQ options.

With XON/ XOFF enabled, the scanner assumes an XON for the first transmission. The scanner transmits data until an XOFF is received from the host device. If an XON is not received within 30 seconds after an XOFF, a transmission error occurs.

Beep on BEL

When enabled, the scanner beeps when a <BEL> character is detected on the RS-232 link. <BEL> may be used to indicate an event such as an illegal entry.

Note: The scanner will not respond to a <BEL> character between decode attempts if the scanner is configured for low power operation.

Troubleshooting and Maintenance

This chapter describes how to troubleshoot and maintain the scanner.

- troubleshooting chart
- cleaning the scan window
- Allen-Bradley Global Technical Support

Troubleshooting the Scanner

This section provides a list of the most common operating problems, the probable causes, and suggested corrective actions.

Problem	Probable Cause(s)	Corrective Action
No Scan Beam.	<ol style="list-style-type: none"> 1. Power supply not connected to Synapse cable. 2. Scan beam has timed out. 3. Defective interface cable. 4. Defective scanner. 	<ol style="list-style-type: none"> 1. Make sure power supply is connected and plugged into a power source. 2. Normal operation. Release trigger completely and scan again. 3. If possible, try another cable. 4. If possible, try another scanner using the same connections. Contact Allen-Bradley Global Support (GTS).
Scan Beam Appears as a Dot Not a line	<ol style="list-style-type: none"> 1. Defective scanner. 	<ol style="list-style-type: none"> 1. Contact Allen-Bradley Global Technical Support.
Scanned data appears incorrectly on a display terminal when using a keyboard wedge cable.	<ol style="list-style-type: none"> 1. Scanner not configured for correct wedge cable. 2. Caps lock is on. 3. Incorrect interface cable. 4. Decoder options not properly configured. 5. Scanned data still appears incorrectly. 	<ol style="list-style-type: none"> 1. Make sure scanner is configured for correct wedge cable. 2. Turn Caps lock off. 3. Check that you are using the proper cable. 4. Check all options such as UPC-E to UPC-A conversion. 5. Contact Allen-Bradley Global Technical Support.

Problem	Probable Cause(s)	Corrective Action
<p>Scan Beam Present, Symbols Not Read</p>	<ol style="list-style-type: none"> 1. Scanner not set to decode symbol type scanned. 2. Scanner not held at slight angle to symbol. 3. Scan beam not crossing entire symbol. 4. Poor quality bar code symbols. 5. Loose cable connections. 6. Incorrect interface cable. 	<ol style="list-style-type: none"> 1. Verify the scanner decoder settings. 2. Hold scanner at an angle to the symbol. 3. Make sure scan beam crosses every bar and space on the symbol. 4. Use the symbols provided on the inside back cover for testing. 5. Check for loose cable connections. 6. Check that you are using the proper cable.
<p>Data is decoded but not transmitted to host.</p>	<ol style="list-style-type: none"> 1. Scanner is not configured for the proper cable. 2. Loose connections 3. Scanner communication settings do not match host requirements. 	<ol style="list-style-type: none"> 1. Make sure the scanner is configured for the correct cable (standard RS-232 or smart cable). 2. Check all cable connections. 3. Verify cable communication settings such as baud rate.

Cleaning the Scan Window

You may need to clean the window of the scanner. **Carefully** clean the window by first removing loose particles of dirt with clean air. Then use an *optical quality cloth* moistened with an *optical quality cleaning fluid* for **plastic lenses** and wipe the window in a single direction (don't wipe cloth back and forth across window). Do not leave streaks.



ATTENTION: Do not use abrasive materials such as disposable wipes and facial tissue. Do not use solvents like alcohol or acetone. These materials will damage the window or the finish on the scanner.



ATTENTION: The scanner has no serviceable parts. Do not open the housing of the scanner.

A-B Technical Support

If you should require assistance or need additional information on operating the scanner or Allen-Bradley decoder, contact Allen-Bradley Global Technical Services (GTS) at **(216) 646-6800**.

Specifications

Optical

Nominal Scan Rate	33 to 39 scans/second
Wavelength (nominal)	675 nm (Visible Red)
Maximum Roll (Skew)	$\pm 10\%$ from normal
Maximum Pitch	$\pm 50\%$ from normal
Maximum Yaw	$\pm 60\%$ from normal
Depth of Field	See page 1-7
Print Contrast (Minimum)	25% absolute dark/light differential
Ambient Light Immunity	
Artificial Lighting	200 ft. candles (2153 lux)
Sunlight	8000 ft. candles (86112 lux)

Electrical

Supply Voltage	4.8 to 14.0V DC
Current	150 mA at 5V DC (typical)

Mechanical

Dimensions	
Inches	5.0 (L) x 2.8 (W) x 6.3 (H)
Millimeters	127 (L) x 71 (W) x 160 (H)
Weight	8.5 oz (240 g)

Environmental

Operating Temperature -22° to 122°F (-30° to 50°C)
Storage Temperature -40° to 140°F (-40° to 60°C)
Humidity 5% to 95% (noncondensing)
Drop Test 6ft (1.8 meter) to concrete

Laser Certifications

CDRH Class II laser product
IEC 825 Class 2

Agency Certifications

UL and CUL Listed
CE marked for all applicable directives

Hands-Free Stand Operation

The scanner operates automatically when used with an adjustable stand:

- 2755-HFN-K1
- 2755-HFN-K2

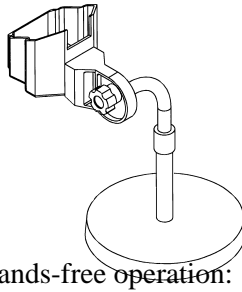

To use the stand for hands-free operation:

1. Adjust the stand at a distance and angle suitable for the labels you are scanning.
2. Place the scanner in the stand, the scanner will turn on and begin scanning. You do not need to press the trigger.
3. The scanner will remain scanning until a readable bar code symbol is placed under the scan line. After reading the label the scanner will stop scanning, attempt to transmit the data, and then resume scanning.
4. If the scanner does not scan a bar code symbol within the configured Stand Operation Timeout, the scanner will enter a reduced power mode (blinking scan). Normal scanning resumes once a bar code symbol is read.

Scanner Pinout Connections

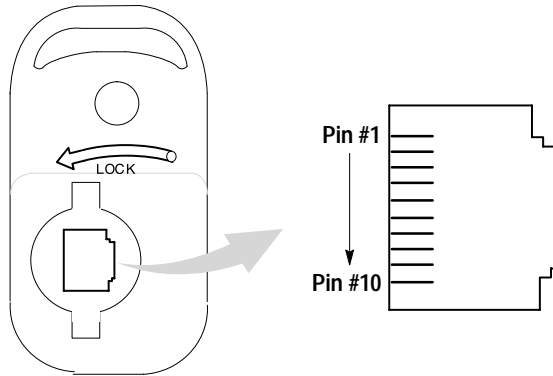

Pin	Function AdaptaScan Pass Through Cable	Function Synapse Cable
1	Not Used	Not Used
2	Power Input (4.8 to 14V DC).	Power Input (4.8 to 14V DC).
3	Power and signal ground.	Power and signal ground.
4	RTS Output	Not Used
5	Receive Data (RxD) Input	Not used
6	Not Used	ZIF Clock
7	DTR Output	Not Used
8	Transmit Data (TxD) Output	Not Used
9	CTS Input	Not Used
10	Not Used	ZIF Data

Appendix D

ASCII Chart

ASCII Value	Full ASCII Code 39 Encode Char.	Character (Control Code)	ASCII Value	Full ASCII Code 39 Encode Char.	Character (Control Code)
1000	%U	NULL (CTRL 2)	1016	\$P	DLE (CTRL P)
1001	\$A	SOH (CTRL A)	1017	\$Q	DC1 (CTRL Q)
1002	\$B	STX (CTRL B)	1018	\$R	DC2 (CTRL R)
1003	\$C	ETX (CTRL C)	1019	\$S	DC3 (CTRL S)
1004	\$D	EOT (CTRL D)	1020	\$T	DC4 (CTRL T)
1005	\$E	ENQ (CTRL E)	1021	\$U	NAK (CTRL U)
1006	\$F	ACK (CTRL F)	1022	\$V	SYN (CTRL V)
1007	\$G	BEL (CTRL G)	1023	\$W	ETB (CTRL W)
1008	\$H	BS (CTRL H)	1024	\$X	CAN (CTRL X)
1009	\$I	HT (CTRL I)	1025	\$Y	EM (CTRL Y)
1010	\$J	LF (CTRL J)	1026	\$Z	SUB (CTRL Z)
1011	\$K	VT (CTRL K)	1027	%A	ESC (CTRL)
1012	\$L	FF (CTRL L)	1028	%B	FS (CTRL \)
1013	\$M	CR (CTRL M)	1029	%C	GS (CTRL])
1014	\$N	SO (CTRL N)	1030	%D	RS (CTRL ^)
1015	\$O	SI (CTRL O)	1031	%E	US (CTRL _)

ASCII Value	Full ASCII Code 39 Encode Char.	Character	ASCII Value	Full ASCII Code 39 Encode Char.	Character
1032	SP	SP	1057	9	9
1033	/A	!	1058	/Z	:
1034	/B	'	1059	%F	;
1035	/C	#	1060	%G	<
1036	/D	\$	1061	%H	=
1037	/E	%	1062	%I	>
1038	/F	&	1063	%J	?
1039	/G	'	1064	%V	@
1040	/H	(1065	A	A
1041	/I)	1066	B	A
1042	/J	*	1067	C	C
1043	/K	+	1068	D	D
1044	/L	,	1069	E	E
1045	-	-	1070	F	F
1046	.	.	1071	G	G
1047	/	/	1072	H	H
1048	0	0	1073	I	I
1049	1	1	1074	J	J
1050	2	2	1075	K	K
1051	3	3	1076	L	L
1052	4	4	1077	M	M
1053	5	5	1078	N	N
1054	6	6	1079	O	O
1055	7	7	1080	P	P
1056	8	8	1081	Q	Q

ASCII Value	Full ASCII Code 39 Encode Char.	Character	ASCII Value	Full ASCII Code 39 Encode Char.	Character
1082	R	R	1105	+I	i
1083	S	S	1106	+J	j
1084	T	T	1107	+K	k
1085	U	U	1108	+L	l
1086	V	V	1109	+M	m
1087	W	W	1110	+N	n
1088	X	X	1111	+O	o
1089	Y	Y	1112	+P	p
1090	Z	Z	1113	+Q	q
1091	%K	[1114	+R	r
1092	%L	\	1115	+S	s
1093	%M]	1116	+T	t
1094	%N	^	1117	+U	u
1095	%O	_	1118	+V	v
1096	%W	'	1119	+W	w
1097	+A	a	1120	+X	x
1098	+B	b	1121	+Y	y
1099	+C	c	1122	+Z	z
1100	+D	d	1123	%P	{
1101	+E	e	1124	%Q	
1102	+F	f	1125	%R	}
1103	+G	g	1126	%S	~
1104	+H	h	1127		Undefined

ALT Key Values

ALT Key Value	Keystroke	ALT Key Value	Keystroke	ALT Key Value	Keystroke
2064	ALT 2	2075	ALT K	2086	ALT V
2065	ALT A	2076	ALT L	2087	ALT W
2066	ALT B	2077	ALT M	2088	ALT X
2067	ALT C	2078	ALT N	2089	ALT Y
2068	ALT D	2079	ALT O	2090	ALT Z
2069	ALT E	2080	ALT P	2091	ALT [
2070	ALT F	2081	ALT Q	2092	ALT \
2071	ALT G	2082	ALT R	2093	ALT]
2072	ALT H	2083	ALT S	2094	ALT 6
2073	ALT I	2084	ALT T	2095	ALT -
2074	ALT J	2085	ALT U		

Miscellaneous Key Values

Misc. Key Value	Keystroke	Misc. Key Value	Keystroke	Misc. Key Value	Keystroke
3001	PA 1	3009	CMD 7	3017	°
3002	PA 2	3010	CMD 8	3018	1/2
3003	CMD 1	3011	CMD 9	3019	
3004	CMD 2	3012	CMD 10	3020	
3005	CMD 3	3013		3021	
3006	CMD 4	3014		3022	0/00
3007	CMD 5	3015			
3008	CMD 6	3016	-		

Numeric Key Values

Numeric Key Value	Keystroke	Numeric Key Value	Keystroke	Numeric Key Value	Keystroke
6042	*	6049	1	6056	8
6043	+	6050	2	6057	9
6044	Undefined	6051	3	6058	Enter
6045	-	6052	4	6059	Num Lock
6046	.	6053	5	6060	00
6047	/	6054	6		
6048	0	6055	7		

Extended Keyapd Key Values

Numeric Key Value	Keystroke	Numeric Key Value	Keystroke	Numeric Key Value	Keystroke
7001	Break	7008	Backspace	7015	Up Arrow
7002	Delete	7009	Tab	7016	Down Arrow
7003	Page Up	7010	Print Screen	7017	Left Arrow
7004	End	7011	Insert	7018	Right Arrow
7005	Page Down	7012	Home	7019	Back Tab
7006	Pause	7013	Enter		
7007	Scroll Lock	7014	Escape		

European Union Directive Compliance **CE**

If the Hand Held Decoded Scanner is installed within the European Union or EEA regions and has the CE mark, the following regulations apply.

EMC Directive

Decoded Hand-Held Bar Code Scanners

This apparatus is tested to meet EMC Directive 89/336/EEC and Low Voltage Directive 73/23/EEC using the following standards, in whole or in part:

- EN 55 022 : 1988
- EN 50 082-1 : 1992
 - IEC 801.2 : 1988
 - IEC 801.3 : 1988
 - IEC 801.4 : 1988
- EN 60 950 : 1992 + A1:1995 + A2:1993
- EN 60 825-1 : 1994

The product described is intended for use in an industrial environment.

Declarations of Conformity

A copy of the Declaration of Conformity is provided on the next page. This document declares that the terminals conform to the applicable directives.

DECLARATION OF CONFORMITY

This Declaration of Conformity is suitable to the European Standard EN 45014, "General criteria for supplier's declaration of conformity." The basis for the criteria has been found in international documentation, particularly in: ISO/IEC Guide 22, 1982, "Information on manufacturer's declaration of conformity with standards or other technical specifications."

Allen-Bradley liability under this declaration is limited to that set forth in the current Allen-Bradley publication 6500, Terms and Conditions of Sale as well as similar publications from Allen-Bradley affiliates doing business in the European Community.

Applied Council Directive(s):
Electromagnetic Compatibility Directive (EMC) 89/336/EEC,
Low Voltage Directive 73/23/EEC,
and amending directives 91/263/EEC, 92/31/EEC, 93/68/EEC

We,			
Manufacturer:	Allen-Bradley Company, Inc. 1201 South 2nd Street Milwaukee, WI 53204 U.S.A.	Authorized Representative in the Community (and location of Responsible Person):	Allen-Bradley, subsidiary of Rockwell International GmbH Düsseldorf Str. 15 D-42781 Haan, Germany

declare under our sole responsibility that the product(s) (name, type/model, batch/serial number):

Hand Held Barcode Scanners identified by the following Allen-Bradley Catalog Number: Bul 2755-HUG-4, -HUG-4X, -HUG-9, -HUG-9X, -HDG-4, -HDG-4X

to which this declaration relates is in conformity with the relevant provisions of the following standard(s) or other normative document(s):

- EN 55 022 : 1988
- EN 50 082-1 : 1992 (IEC 801.2 : 1988, IEC 801.3 : 1988, IEC 801.4 : 1988)
- EN 60 950 : 1992 + A1 : 1993 + A2 : 1993
- EN 60 825-1 : 1994

Test Information is maintained at:
Allen-Bradley Company, Inc.
1201 South Second Street
Milwaukee, WI 53204 USA

Year of CE Marking (Low Voltage Directive): 1996

We, the undersigned, hereby declare that the product(s) specified above conforms to the listed directive(s) and standard(s).

Manufacturer
Signature

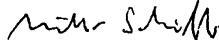

Authorized Representative in the Community through its Responsible Person
Signature

i.v. 

Full Name: Robert Gardiner
Position: Manager, Quality Engineering
Date: 11 Sept, 1996

Full Name: Viktor Schiffer
Position: Engineering Manager
Date: 11 Sept, 1996

Glossary

A

ASCII

American Standard Code for Information Interchange.

A 7 bit-plus-parity code representing 128 letters, numerals, punctuation marks, and control characters. It is a standard data transmission code in the U.S.

B

Bit

Binary digit. One bit is the basic unit of binary information. Generally, eight consecutive bits compose one byte of data. The pattern of 0 and 1 values within the byte determines its meaning.

Byte

On an addressable boundary, eight adjacent binary digits (0 and 1) combined in a pattern to represent a specific character or numeric value. Bits are numbered from the right, 0 through 7, with bit 0 the low-order bit. One byte in memory can be used to store one ASCII character.

C

CDRH

Center for Devices and Radiological Health. A federal agency responsible for regulating laser product safety. This agency specifies various laser operation classes based on power output during operation.

Check Digit

A digit used to verify a correct symbol decode. The scanner inserts the decoded data into an arithmetic formula and checks that the resulting number matches the encoded check digit. Check digits are required for UPC but are optional for other symbologies. Using check digits decreases the chance of substitution errors when a symbol is decoded.

Codabar

A discrete self-checking code with a character set consisting of digits 0 to 9 and six additional characters: (- \$: / , +).

Code 128

A high density symbology which allows the controller to encode all 128 ASCII characters without adding extra symbol elements.

Code 3 of 9 (Code 39)

A versatile and widely used alphanumeric bar code symbology with a set of 43 character types, including all uppercase letters, numerals from 0 to 9, and 7 special characters (- . / + % \$ and space). The code name is derived from the fact that 3 of 9 elements representing a character are wide, while the remaining 6 are narrow.

Code 93

An industrial symbology compatible with Code 39 but offering a full character ASCII set and a higher coding density than Code 39.

Continuous Code

A bar code or symbol in which all spaces within the symbol are parts of characters. There are no intercharacter gaps in a continuous code. The absence of gaps allows for greater information density.

D

Decode

To recognize a bar code symbology (e.g., UPC/EAN) and then analyze the content of the specific bar code scanned.

Decode Algorithm

A decoding scheme that converts pulse widths into data representation of the letters or numbers encoded within a bar code symbol.

Discrete Code

A bar code or symbol in which the spaces between characters (intercharacter gaps) are not part of the code.

Discrete 2 of 5

A binary bar code symbology representing each character by a group of five bars, two of which are wide. The location of wide bars in the group determines which character is encoded; spaces are insignificant. Only numeric characters (0 to 9) and START/STOP characters may be encoded.

E

EAN

European Article Number. This European/International version of the UPC provides its own coding format and symbology standards. Element dimensions are specified metrically. EAN is used primarily in retail.

H

Host Computer

A computer that serves other terminals in a network, providing such services as computation, database access, supervisory programs, and network control.

I

IEC

International Electrotechnical Commission. This international agency regulates laser safety by specifying various laser operation classes based on power output during operation.

Intercharacter Gap

The space between two adjacent bar code characters in a discrete code.

Interleaved Bar Code

A bar code in which characters are paired together, using bars to represent the first character and the intervening spaces to represent the second.

Interleaved 2 of 5

A binary bar code symbology representing character pairs in groups of five bars and five interleaved spaces. Interleaving provides for greater information density. The location of wide elements (bar/spaces) within each group determines which characters are encoded. This continuous code type uses no intercharacter spaces. Only numeric (0 to 9) and START / STOP characters may be encoded.

L

Laser

An acronym for Light Amplification by Stimulated Emission of Radiation. The laser is an intense light source. Light from a laser is all the same frequency, unlike the output of an incandescent bulb. Laser light is typically coherent and has a high energy density.

Laser Diode

A gallium-arsenide semiconductor type of laser connected to a power source to generate a laser beam. This laser type is a compact source of coherent light.

P

Parameter

A variable that can have different values assigned to it.

Programming Mode

The state in which a scanner is configured for parameter values. See **SCANNING MODE**.

Q

Quiet Zone

A clear space, containing no dark marks, which precedes the start character of a bar code symbol and follows the stop character.

S

Scanner

An electronic device used to scan bar code symbols and produce a digitized pattern that corresponds to the bars and spaces of the symbol. Its three main components are:

1. Light source (laser or photoelectric cell) - illuminates a bar code.
2. Photodetector - registers the difference in reflected light (more light reflected from spaces).
3. Signal conditioning circuit - transforms optical detector output into a digitized bar pattern.

Scanning Mode

The scanner is energized, programmed, and ready to read a bar code.

Scanning Sequence

A method of programming or configuring parameters for a bar code reading system by scanning bar code menus.

Self Checking Code

A symbology that uses a checking algorithm to detect encoding errors within the characters of a bar code symbol.

Start / Stop Character

A pattern of bars and spaces that provides the scanner with start and stop reading instructions and scanning direction. The start and stop characters are normally to the left and right margins of a horizontal code.

Symbol

A scannable unit that encodes data within the conventions of a certain symbology, usually including start/stop characters, quiet zones, data characters, and check characters.

Symbology

The structural rules and conventions for representing data within a particular bar code type (e.g. UPC/EAN, Code 39).

U

UPC

Universal Product Code. A relatively complex numeric symbology. Each character consists of two bars and two spaces, each of which can be any of four widths. The standard symbology for retail food packages in the United States.

A

- Accessories
 - AdaptaScan Pass Through Cable, 1-10
 - Keyboard Wedge Cable, 1-9
 - Protective Boot, 1-11
 - RS-232 Cable, 1-8
 - Scanner Cable, 1-8
 - Stands, 1-10
- ACK/NAK, 4-6, 4-28
- AdaptaScan Pass Through Cable, 1-10, 2-3
 - Baud Rate, 4-25
 - Beep on BEL, 4-29
 - Connecting, 2-10
 - Data Bits, 4-26
 - Defaults, 4-24
 - Hardware Handshaking, 4-27
 - Intercharacter Delay, 4-26
 - Parity, 4-25
 - Scanner Pinouts, C-1
 - Software Handshaking, 4-28
 - Stop Bits, 4-26
 - Wiring Base Connections, 2-11
- Advanced Features
 - DEC VT520 Wedge Cable, 4-15
 - IBM PC Wedge Cable, 4-12
 - RS-232 Synapse Cable, 4-8
 - Scanner Emulation Cable, 4-23
- ASCII Chart, D-1
- Audible Response, 2-18
- Audience, Intended, P-1
- Automatic Shutoff, 2-18

B

- Bar Codes, Configuration, 3-1
- Baud Rate
 - AdaptaScan Pass Through Cable, 4-25
 - RS-232 Synapse Cable, 4-3
- Beep
 - Audible Response, 2-18
 - Codes, 2-18
- BEL, Beep on, 4-7, 4-29
- Boot, Protective, 1-11
- Buffer
 - Clear, 3-9
 - Using, 3-9
 - Send, 3-10

C

- Cables
 - AdaptaScan Pass Through, 3-4
 - Connecting AdaptaScan Pass Through, 2-10
 - Connecting Keyboard Wedge, 2-9
 - Connecting RS-232, 2-7
 - Connecting Scanner Emulation, 2-5
 - DEC VT220/320/420, 4-16, 4-18
 - DEC VT520, 4-13
 - Defaults, 4-1
 - IBM PC Wedge, 4-9
 - Keyboard Wedge, 1-9, 2-8
 - Overview, 2-2
 - RS-232, 1-8, 2-6
 - RS-232 Smart Cable, 4-2
 - Scanner, 1-8, 2-3
 - Scanner Emulation, 1-10, 2-5, 4-19
 - Synapse, 1-8, 3-4
- Certifications, A-2

Check Digits

- Code 39, 3-9
- MSI Plessey, 3-11
- UPC / EAN, 3-5

Cleaning, 5-4

CLSI Editing, 3-8

Codabar

- CLSI Editing, 3-8
- Decode Redundancy, 3-8
- NOTIS Editing, 3-8

Code 39

- Buffer, 3-9
- Buffer Beep Codes, 2-19
- Check Digit, 3-9
- Clear Buffer, 3-9
- Full ASCII, 3-10
- Full ASCII Encoding, D-1, D-4, D-5
- Send Buffer, 3-10

Code ID, 3-14

Code Lengths

- Discrete 2 of 5, 3-12
- Interleaved 2 of 5, 3-12

Configuration

- Audible Response Options, 3-17
- Bar Codes, 3-1
- Cable Type Selection, 3-4
- Codabar Options, 3-8
- Code 39 Options, 3-9, 3-10
- Data Format Options, 3-13
- Discrete 2 of 5 Options, 3-12
- Important Notes On, 3-1
- Interleaved 2 of 5 Options, 3-12
- Laser Options, 3-17
- MSI Plessey Options, 3-11
- Options, 1-4
- Selecting Symbolologies, 3-4
- UPC / EAN Options, 3-5, 3-6

Convert

- 12 of 5 to EAN 13, 3-12

Publication 2755-6.2

UPC E to A, 3-5

Convert to Code 39, Scanner Emulation Cable, 4-22

Convert to Full ASCII, Scanner Emulation Cable, 4-22

Country Selection

- DEC VT220/320/420 Wedge Cable, 4-17
- DEC VT520 Wedge Cable, 4-14
- IBM PC Wedge Cable, 4-10

D

Data Bits

- AdaptaScan Pass Through Cable, 4-26
- RS-232 Synapse Cable, 4-4

Data Formats, 3-13

DEC VT220/320/420 Wedge Cable

- Country Selection, 4-17
- Defaults, 4-16
- Host Selection, 4-16
- Intercharacter Delay, 4-17
- Unknown Characters, 4-17

DEC VT520 Wedge Cable

- Advanced Features, 4-15
- Country Selection, 4-14
- Defaults, 4-13
- Host Selection, 4-14
- Intercharacter Delay, 4-15
- Unknown Characters, 4-14

Declarations of Conformity, E-1

Decode Beep, 3-17

Decode LED, Scanner Emulation Cable, 4-20

Decode Redundancy, 3-8

Decoding, Symbolologies, 1-4

Defaults

AdaptaScan Pass Through Cable,
4-24
Cable, 4-1
DEC VT220/320/420 Wedge
Cable, 4-16
DEC VT520 Wedge Cable, 4-13
IBM PC Wedge Cable, 4-9
Scanner Emulation Cable, 4-19
Discrete 2 of 5, Code Lengths, 3-12

E

Electrical Specifications, A-1
Emulation Type, Scanner Emulation
Cable, 4-20
Enhanced Decoder, Connecting to
Scanner, 2-12, 2-13
ENQ, Hardware Handshaking, 4-6,
4-28
Environmental Specifications, A-2
Error, Beep Codes, 2-18

F

Features, 1-2
Flexible Interface Module,
Connecting to Scanner, 2-14
Full ASCII, Code 39, 3-10

G

Global Technical Support, 5-4
Gun Adapter, for Enhanced Decoder,
2-12

H

Hands-Free Operation, B-1

Handshaking
AdaptaScan Pass Through Cable,
4-27, 4-28
Hardware RS-232 Synapse
Cable, 4-5
Software RS-232 Synapse Cable,
4-6
Host Selection
DEC VT220/320/420 Wedge
Cable, 4-16
IBM PC Wedge Cable, 4-10
Rs-232 Synapse Cable, 4-3

I

IBM PC Wedge Cable
Advanced Features, 4-12
Country Selection, 4-10
Defaults, 4-9
Host Selection, 4-10
Intercharacter Delay, 4-11
Unknown Characters, 4-11

ID

AIM, 3-14
Code, 3-14

Intercharacter Delay

AdaptaScan Pass Through Cable,
4-26
DEC VT220/320/420 Wedge
Cable, 4-17
DEC VT520 Wedge Cable, 4-15
IBM PC Wedge Cable, 4-11

Interleaved 2 of 5

Code Lengths, 3-12
EAN 13 Conversion, 3-12

K

Keyboard Wedge Cable, 1-9, 2-8
Connecting, 2-9

L

Label, Scanning, 2-17

Laser

 Certifications, A-2

 Timeout, 3-17

 Warning Label, 1-5

 Warning Symbol, P-3

Leading Margin, Scanner Emulation
 Cable, 4-20

LEDs

 Decode, 1-3

 Green, 1-3

 Location, 1-2

 Red, 1-3

M

Mechanical Specifications, A-1

MSI Plessey

 Check Digit, 3-11

 Check Digit Algorithm, 3-11

N

NAK/ ACK, 4-6, 4-28

No Read Message, 3-13

NOTIS Editing, 3-8

O

Operation, 2-17

Optical Specifications, A-1

P

Parity

 AdaptaScan Pass Through Cable,
 4-25

 RS-232 Synapse Cable, 4-4

PLC Controller, Connecting to
 Scanner, 2-15

Polarity, Scanner Emulation Cable,
 4-21

Power Mode, 3-17

Power Supply, 1-9, 2-5, 2-6

Prefix Data, 3-13

Protective Boot, 1-11

Protocol Cartridge, for Flexible
 Interface Module, 2-14

Publication, Related, P-3

R

Read Range, Chart, 1-7

Read Ranges, 1-6

Related Publications, P-3

Response, Audible, 2-18

Response Timeout, RS-232
 Synapse Cable, 4-7

RS-232 Cable, 1-8, 2-6

 Advanced Features, 4-8

 Baud Rate, 4-3

 Beep on BEL, 4-7

 Check Parity, 4-4

 Connecting, 2-7

 Connecting to PLC, 2-15

 Connecting to SLC, 2-16

 Data Bits, 4-4

 Defaults, 4-2

 Hardware Handshaking, 4-5

 Parity, 4-4

 Response Timeout, 4-7

Software Handshaking, 4-6
 Stop Bits, 4-4
 RTS State, RS-232 Synapse Cable,
 4-5

S

Scanner

Audible Response, 2-18
 Automatic Shutoff, 2-18
 Beep Codes, 2-18
 Cable, 1-8, 2-3
 Cleaning, 5-4
 Connecting to Enhanced Decoder,
 2-12, 2-13
 Connecting to Flexible Interface
 Module, 2-14
 Connecting to PLC Controller,
 2-15
 Connecting to SLC Controller,
 2-16
 Emulation Cable, 1-10, 2-5
 Features, 1-2
 Operating, 2-17
 Pinout Connections, C-1
 Scanning Position, 2-17
 Testing, 2-17
 Troubleshooting, 5-2
 Scanner , Read Ranges, 1-6
 Scanner Emulation Cable, 1-10
 Advanced Features, 4-23
 Convert to Code 39, 4-22
 Convert to Full ASCII, 4-22
 Decode LED, 4-20
 Defaults, 4-19

Emulation Type, 4-20
 Leading Margin, 4-20
 Polarity, 4-21
 Timeout, 4-21
 Unknown Characters, 4-21

Scanning

Beep Codes, 2-18
 Labels, 2-17
 Security Levels, UPC / EAN, 3-7
 SLC Controller, Connecting to
 Scanner, 2-16

Specifications

Electrical, A-1
 Environmental, A-2
 Mechanical, A-1
 Optical, A-1

Stand, Timeout, 3-17

Stands

Hands-Free Operation, B-1
 Standard and Adjustable, 1-10

Stop Bits

AdaptaScan Pass Through Cable,
 4-26
 RS-232 Synapse Cable, 4-4

Suffix Data, 3-13

Supplemental Characters, UPC /
 EAN, 3-5

Supplemental Digits,
 Autodiscrimination of, 3-5

Support, GTS, 5-4

Symbologies

Available, 1-4
 Selecting, 3-4

T

Technical Support, GTS, 5-4
Telephone No., Technical Support,
5-4
Testing, 2-17
Timeout
 Laser, 3-17
 RS-232 Synapse Cable, 4-7
 Scanner Emulation Cable, 4-21
 Stand, 3-17
Transmission Formats, 3-13
Troubleshooting, 5-2

U

Unknown Characters
 DEC VT220/320/420 Wedge
 Cable, 4-17
 DEC VT520 Wedge Cable, 4-14
 IBM PC Wedge Cable, 4-11
 RS-232 Synapse Cable, 4-7

Scanner Emulation Cable, 4-21

UPC / EAN

Autodiscriminate Supplements,
3-5
Check Digits, 3-5
Convert UPC E to A, 3-5
Decode Supplementals, 3-5
EAN 8 Zero Extend, 3-6
Preambles, 3-6
Security Level, 3-7

W

Warning
 Laser Light, P-3
 Safety Label, 1-5

X

XON/XOFF, Hardware Handshaking,
4-6, 4-28

TEST SYMBOLS



1 2 3 4 5

Code 128



1 2 3 4 5

Code 93



A 1 2 3 4 B

Codabar



A 1 2 3 4 B

Code 39

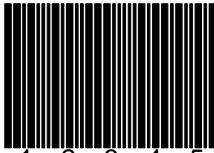

1 2 3 4 5

Discrete 2 of 5



1 2 3 4 5

EAN 128



1 2 3 4 5 6 7 8 9 10 19

EAN 13



1 2 3 4 5 6 7 0

EAN 8

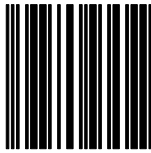

0 1 2 3 4 5

Interleaved 2 of 5



1 2 3 4 5 6 7 8 9 0 1 2

UPC A

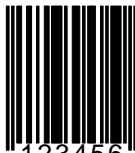

0 1 2 3 4 5 6 5

UPC E

Synapse is a trademark of Symbol Technologies Inc.
AdaptaScan is a trademark of Allen-Bradley

 **Rockwell** Automation

Allen-Bradley

Worldwide representation.



Argentina • Australia • Austria • Bahrain • Belgium • Brazil • Bulgaria • Canada • Chile • China, PRC • Colombia • Costa Rica • Croatia • Cyprus • Czech Republic • Denmark • Ecuador • Egypt • El Salvador • Finland • France • Germany • Greece • Guatemala • Honduras • Hong Kong • Hungary • Iceland • India • Indonesia • Ireland • Israel • Italy • Jamaica • Japan • Jordan • Korea • Kuwait • Lebanon • Malaysia • Mexico • Netherlands • New Zealand • Norway • Pakistan • Peru • Philippines • Poland • Portugal • Puerto Rico • Qatar • Romania • Russia-CIS • Saudi Arabia • Singapore • Slovakia • Slovenia • South Africa, Republic • Spain • Sweden • Switzerland • Taiwan • Thailand • Turkey • United Arab Emirates • United Kingdom • United States • Uruguay • Venezuela • Yugoslavia

Allen-Bradley Headquarters, 1201 South Second Street, Milwaukee, WI 53204 USA, Tel: (1) 414 382-2000 Fax: (1) 414 382-4444